

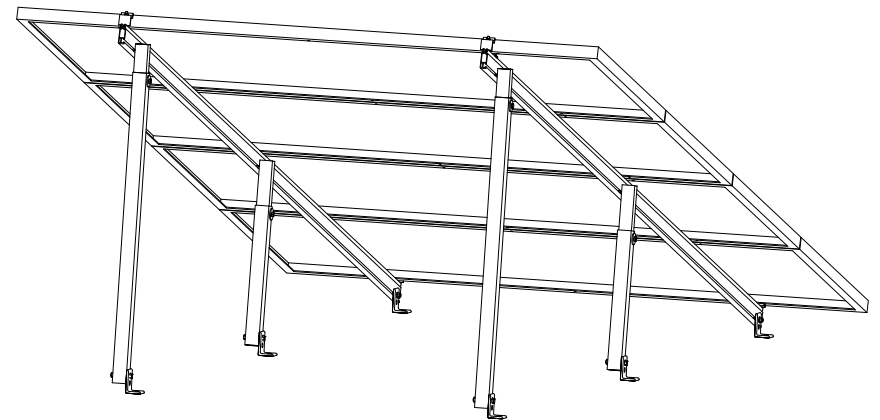

SOLARMOUNT TILT LEG
LOW & HIGH PROFILE

INSTALLATION GUIDE

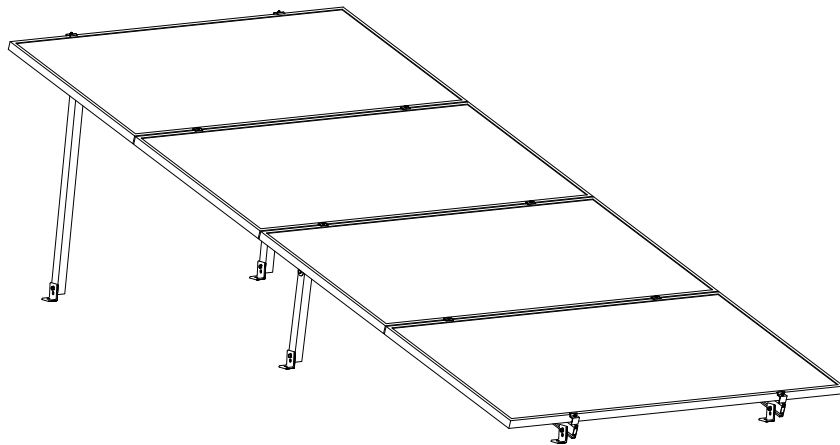

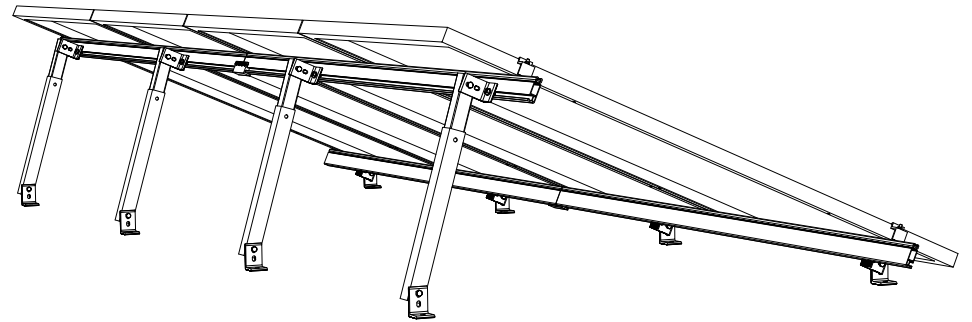
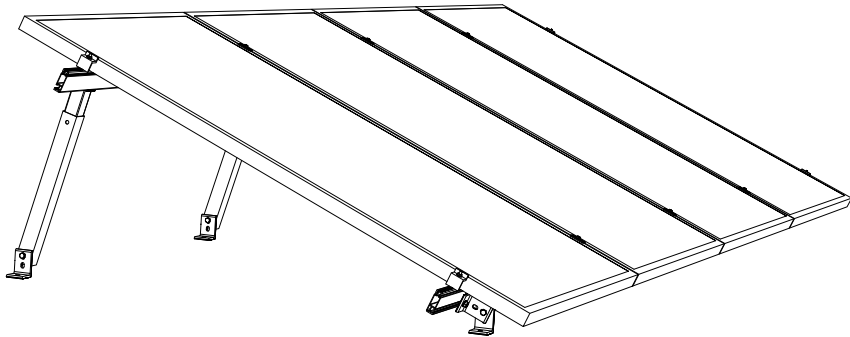

SOLAR MOUNT TILT LEG LOW & HIGH PROFILE

TILT LEG COMPONENTS : A INSTALLATION GUIDE : PAGE

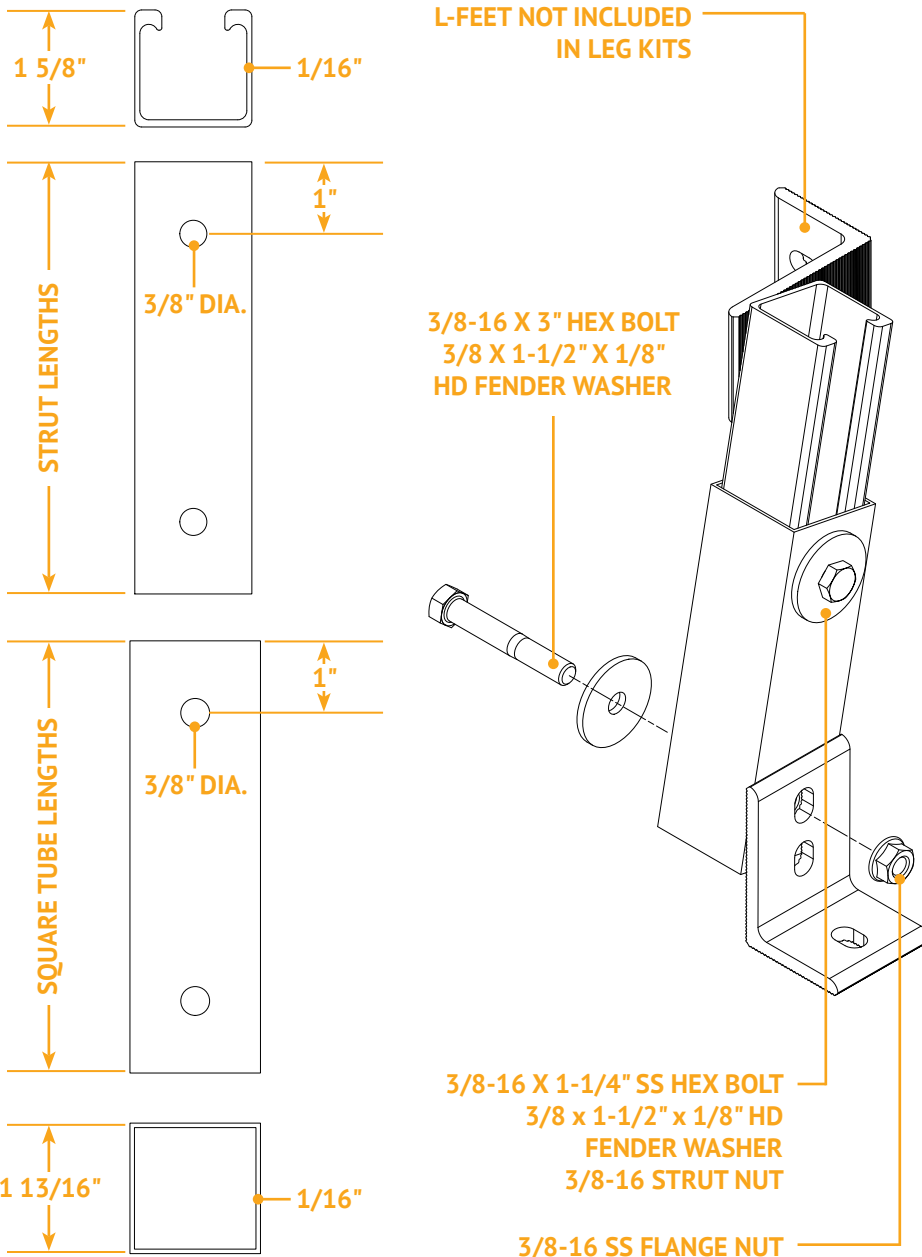

TILT LEG LENGTHS		
Total Adjustable Lengths	Square Tube	Strut
8" to 12"	8"	8"
18" to 30"	18"	18"
26" to 44"	26"	26"
40" to 72"	40"	40"

Properties	Tilt Leg Strut Channel	Square Tilt Leg Tube	Units
Area	0.515	0.4884	in ²
Weight	0.57	0.56	plf
Width	1.625	1.82	in
Height	1.625	1.82	in
Section Modulus (X-axis)	0.236	0.275	in ³
Section Modulus (Y-axis)	0.261	0.275	in ³
Moment of Inertia (X-axis)	0.201	0.2498	in ⁴
Moment of Inertia (Y-axis)	0.213	0.2498	in ⁴
Radius of Gyration (X-axis)	0.625	0.7152	in

Wrenches and Torque	Wrench Size	Recommended Torque (ft-lbs)
3/8" Hardware	9/16"	*30 w/Anti-Seize

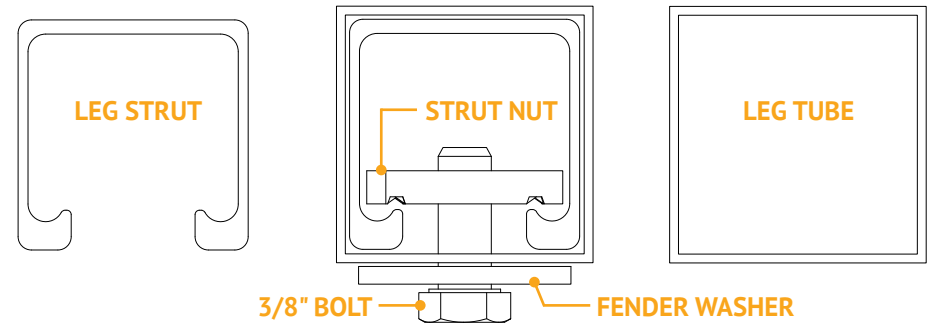

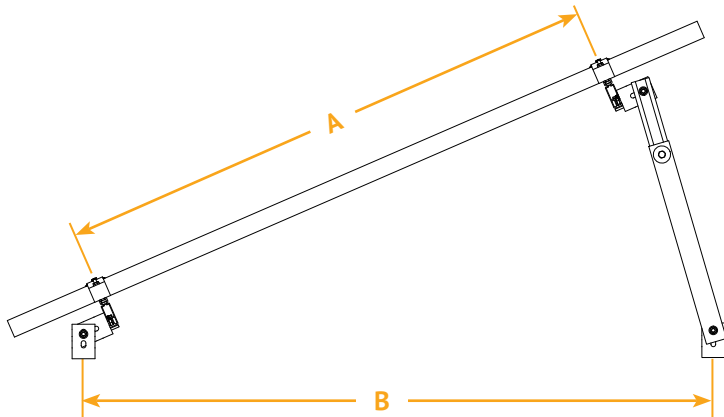

PREFERRED TILT LEG ORIENTATION

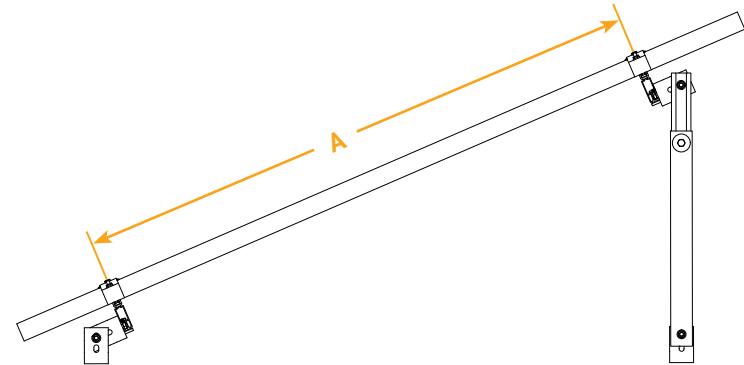

ACCEPTABLE TILT LEG ORIENTATION

A vertical leg orientation is acceptable. but DO NOT allow the bottom of the tilt legs for any application to be angled inboard towards the front of the array.

**For more information on module placement please refer to the SOLARMOUNT installation guide.
Remember to comply with module manufacturer clamping requirements**

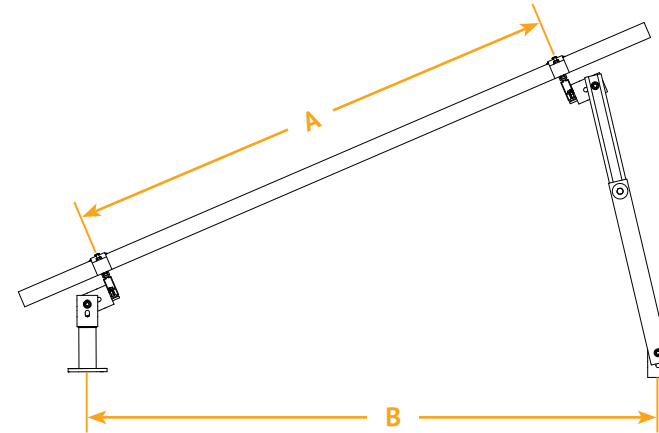
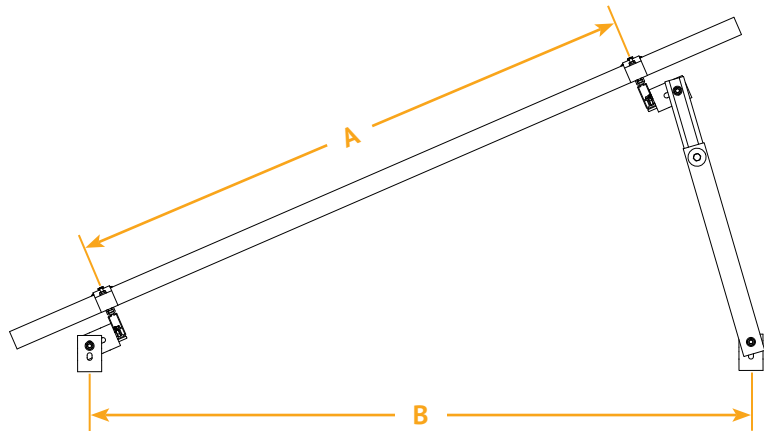

North/south distance along the attachment surface (B) can be obtained using Unirac's U-Builder design & layout tool:

http://design.unirac.com/tool/project_info/solarmount_2/

It is approximately equal to the distance up the module from bottom to the upper rail (A).

NOTE: If you need to install the lower rail further above the bottom edge of the module, add a standoff under the front attachment to increase the height off the surface.

NOTE: Experienced installers have been very successful with SOLARMOUNT Tilt by utilizing an easily made brace during installation. The brace is comprised of a beam (supplied by others such as a piece of strut, but could also be a piece of SOLARMOUNT rail) and four (4) L-feet. The purpose of the brace is to temporarily, but firmly, position rails perpendicular to module frame and parallel to each other at the desired tilt angle. Once modules have been properly fastened to the SOLARMOUNT rail top slot, the braces can be removed. This saves time by keeping rails positioned correctly as module installation begins.

For more information on module placement please refer to the SOLARMOUNT installation guide.

Remember to comply with module manufacturer clamping requirements

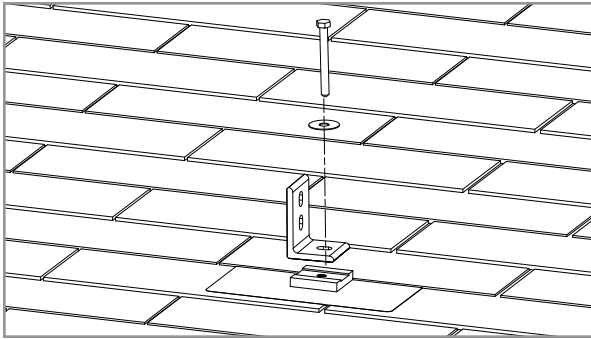

ATTACH L-FOOT: Attach L-Foot to roof attachment assembly

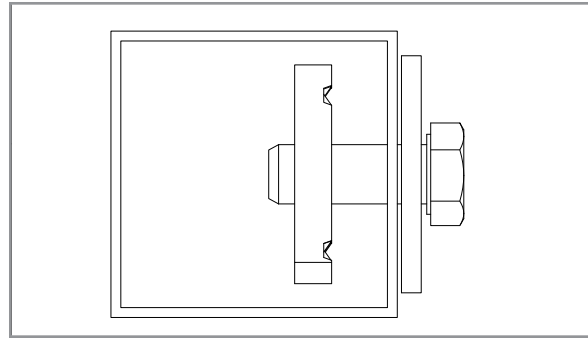

ASSEMBLE TILT LEG:
1) Place fender washer on 3/8" bolt
2) Loosely start strut nut on bolt

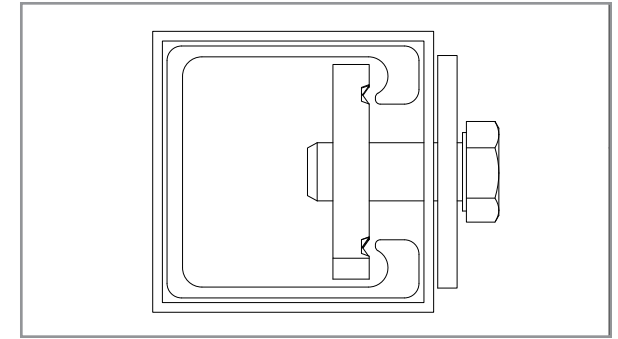

ASSEMBLE TILT LEG (CONT):
3) Slide strut into tube with nut positioned as shown
4) Tighten bolt at desired leg length

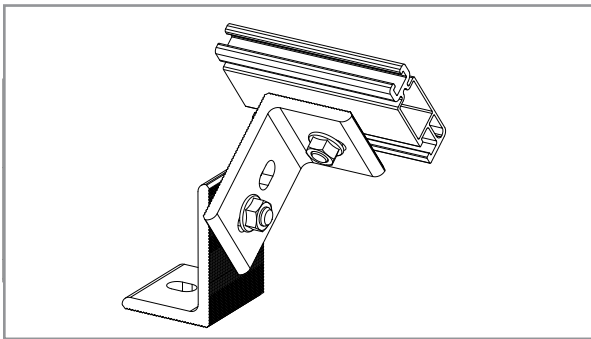

ATTACH L-FEET - BOTTOM RAIL:
Attach L-foot to the rail as show within picture and secure to L-foot already secure to roof attachment.

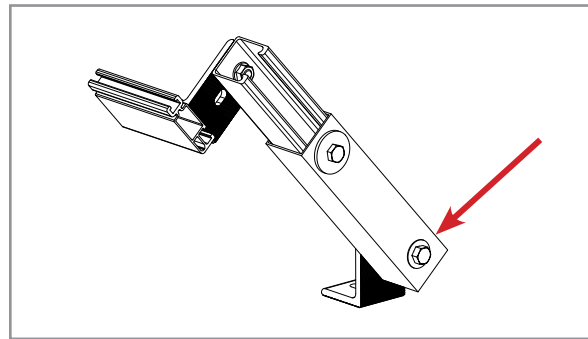

ATTACH TILT LEG TO L-FOOT:
Add L-foot to bottom hole in tube using fender washer and 3/8" bolt and flange nut to form rear attachment.

TORQUE VALUE EXCEPTION:
3/8" nut to 15 ft-lbs w/Anti-Seize
(Lower torque required to avoid crushing tube)

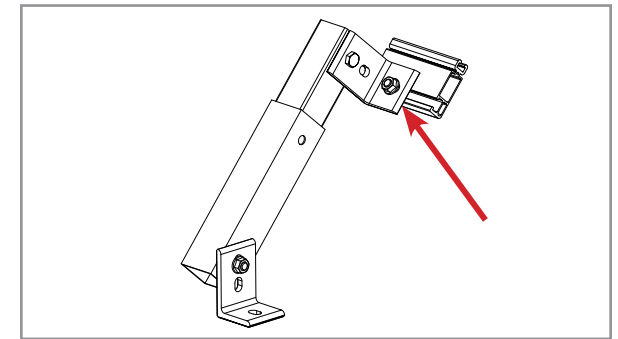

ATTACH L-FOOT TO TOP RAIL:
Attach L-foot to strut using short 3/8" bolt and nut. Attach upper rail to L-foot.

TORQUE VALUE:
3/8" nut to 30 ft-lbs w/Anti-Seize

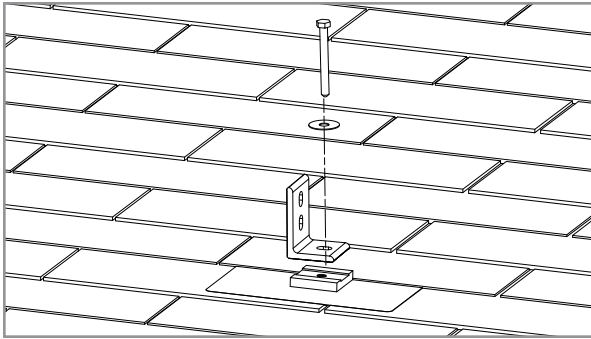

ATTACH L-FOOT: Attach L-Foot to roof attachment assembly.

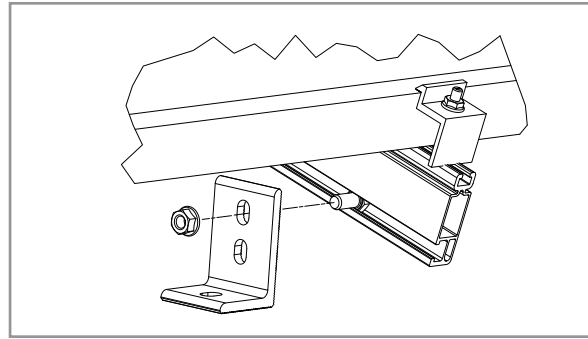

TYPICAL ATTACHMENT - L-FOOT TO RAIL: Attach L-foot to the SM rail by sliding the head of the 3/8" bolt into the slot in the rail and then through the upper hole in the L-foot and then tighten the flange nut.

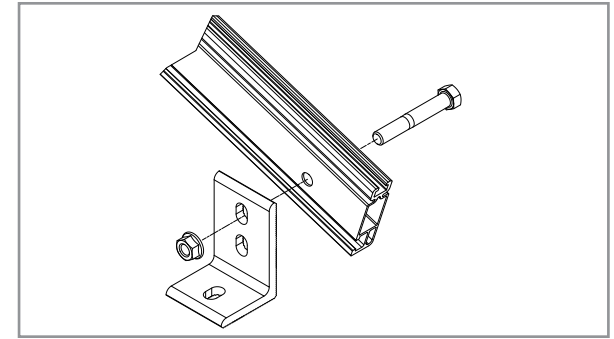

ALTERNATE ATTACHMENT - L-FOOT TO RAIL: Drill 3/8" hole through rail for alternate attachment.

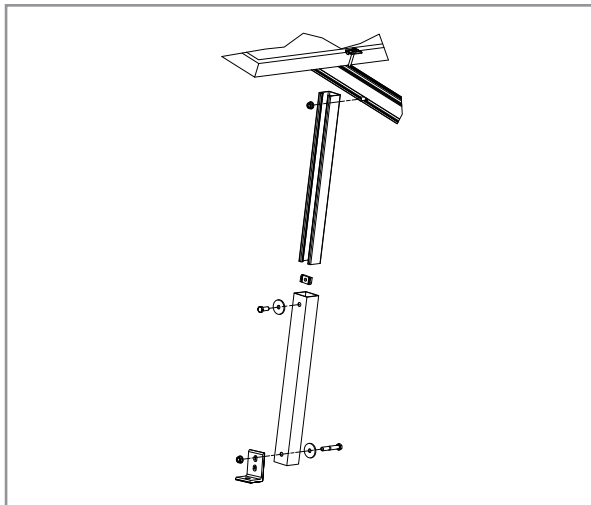

EXPLODED ASSEMBLY VIEW: For Reference Only

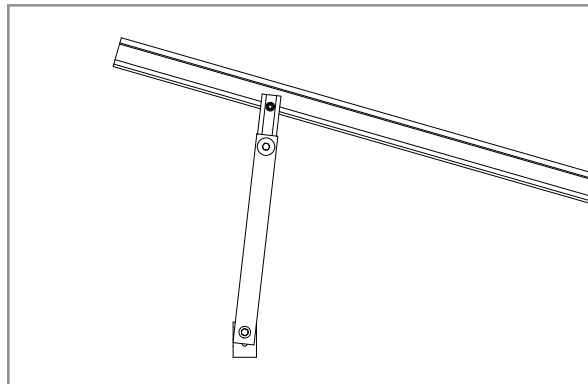

CONNECT TILT LEG TO RAIL: Slide 3/8" Bolt into rail slot and attach to strut with flange nut.

TORQUE VALUE:
3/8" nut to 30 ft-lbs w/Anti-Seize

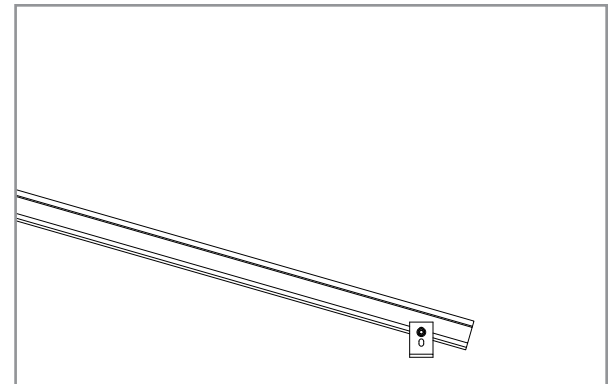

CONNECT L-FOOT TO RAIL: Slide head of the 3/8" Bolt into rail slot and then through the upper hole in L-Foot and tighten with flange nut.

TORQUE VALUE:
3/8" nut to 30 ft-lbs w/Anti-Seize



Approximate Leg Spacing for 4 Leg Supports

A= 0.7 x Rail Length (N-S Leg Spacing)

B= 0.3 x Rail Length (Rail Overhang)

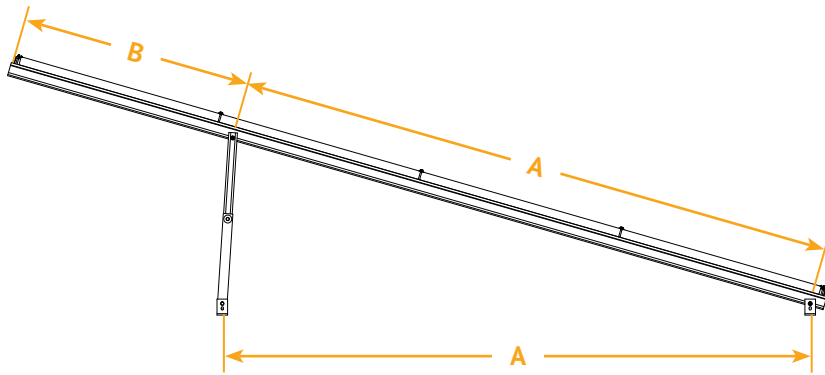

SM RAIL LENGTH (Example Spacing Values)	A	B
132" Rail	92"	40"
168" Rail	118"	50"

SM HD RAIL LENGTH (Example Spacing Values)	A	B
144" Rail	101"	43"
168" Rail	118"	50"

NOTE: DO NOT SPLICE RAILS ON HIGH PROFILE TILT APPLICATIONS

To determine which type of rail is required. Obtain a high profile tilt engineering report by submitting our eQuestionnaire. The service is free of charge. <http://unirac.com/configurators/equestionnaire>

For more information on module placement please refer to the SOLARMOUNT installation guide.
Remember to comply with module manufacturer clamping requirements

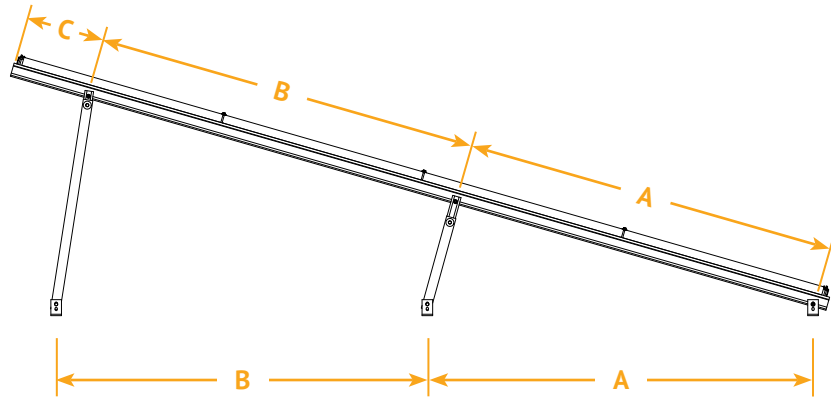

Approximate Leg Spacing for 4 Leg Supports

A= 0.40 x Rail Length (N-S Leg Spacing)

B= 0.45 x Rail Length (N-S Leg Spacing)

C= 0.15 x Rail Length (Rail Overhang)

SM RAIL LENGTH (Example Spacing Values)	A	B	C
132" Rail	52"	60"	20"
168" Rail	67"	76"	25"

SM HD RAIL LENGTH (Example Spacing Values)	A	B	C
144" Rail	58"	65"	21"
168" Rail	67"	76"	25"
204" Rail	82"	92"	30"

NOTE: DO NOT SPLICE RAILS ON HIGH PROFILE TILT APPLICATIONS

To determine which type of rail is required. Obtain a high profile tilt engineering report by submitting our eQuestionnaire. The service is free of charge. <http://unirac.com/configurators/equestionnaire>

For more information on module placement please refer to the SOLARMOUNT installation guide.
Remember to comply with module manufacturer clamping requirements