

RAPIDRAC G10

Code-Compliant Installation Manual 650.1

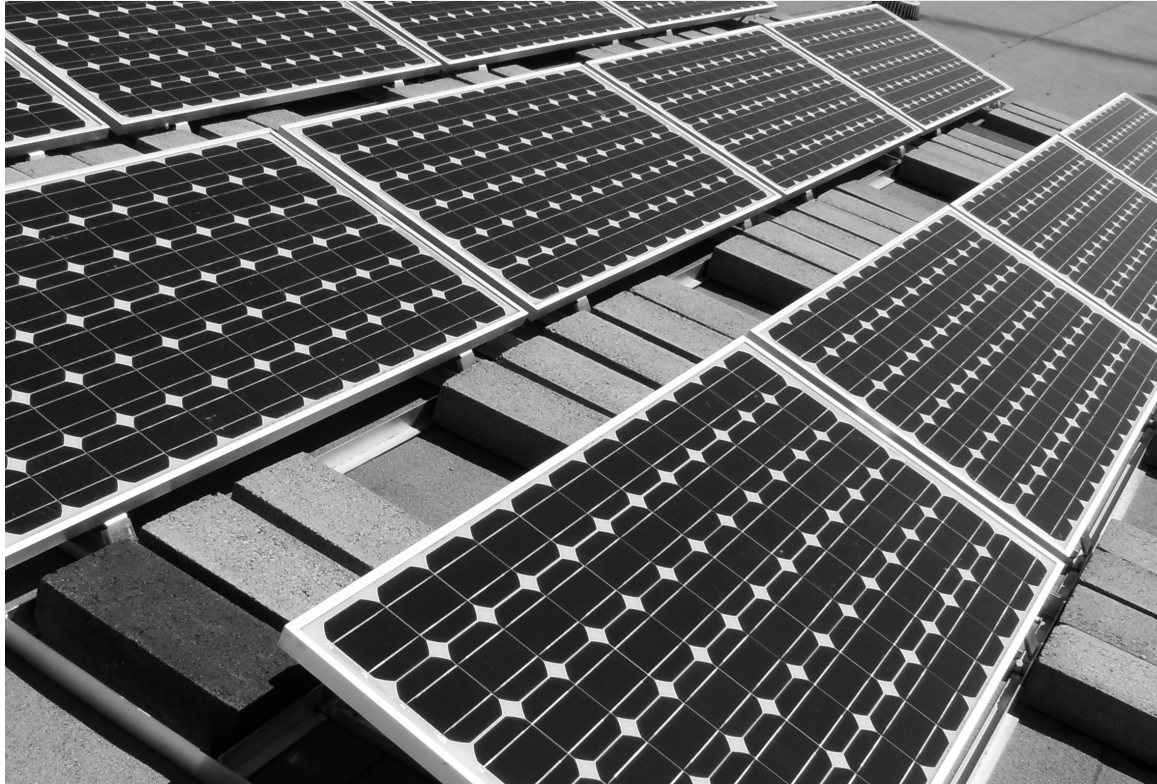

Unirac Code-Compliant Installation Manual

Table of Contents

i. Installer's Responsibilities	2
Part I. Procedure to Determine Wind Design Load	
[1.1.] Using the Analytical Method – ASCE 7-05.....	3
[1.2.] Procedure to Calculate Design Wind Load.....	3 - 6
Part II. Load Forces on RapidRac™ G10 Mounting System	7 - 11
Part III Ballast Distribution Requirements	12
Part IV. Installing RapidRac™ G10	
[4.1.] Tools Required for Assembly.....	13
[4.2.] Components List	13
[4.3.] Assembly	14-15
Part V. 10-Year Limited Product Warranty, 5-Year Limited Finish Warranty.	16



Pub 100804-1cc
August 2010

i. Installer's Responsibilities

Please review this manual thoroughly before installing your RapidRac™ G10 system.

This manual provides a) supporting documentation for building permit applications relating to Unirac's RapidRac™ G10 ballasted flat-roof photovoltaic racking system and b) planning and assembly instructions for RapidRac™ G10.

RapidRac™ G10 products, when installed in accordance with this bulletin, will be structurally adequate and will meet the structural requirements of the IBC 2006, ASCE 7-05, and California Building Code 2007 (collectively referred to as "the Code"). Unirac also provides a limited warranty on RapidRac™ G10 products (p. 16).

RapidRac™ G10 is much more than a product. It's a flat roof solution that accommodates a wide range of modules, providing customers with flexibility & options.

Minimal parts, faster installation, reduced labor expenses and versatility; all customer-driven demands that helped engineer this unique flat roof solution.

It's accompanied by a technical support system that provides this complete installation and code compliance documentation, an on-line Estimator and design assistance to help you solve the toughest challenges.



The installer is solely responsible for:

- Complying with all applicable local or national building codes, including any that may supersede this manual;
- Ensuring that Unirac and other products are appropriate for the particular installation and the installation environment;
- Ensuring that the roof, its rafters, connections, and other structural support members can support the array under all code loading conditions (this total building assembly is referred to as the building structure);
- Using only Unirac parts and installer-supplied parts as specified by Unirac (substitution of parts may void the warranty and invalidate the letters of certification in all Unirac publications);
- Ensuring the fasteners used in the attachment of the racking to the building structure have adequate strength capacities as installed;
- Maintaining the waterproof integrity of the roofing membrane, including selection of appropriate flashing;
- Ensuring safe installation of all electrical aspects of the PV array; and
- Ensuring correct and appropriate design parameters are used in determining the design loading used for design of the specific installation. Parameters, such as snow loading, wind speed, exposure, and topographic factor should be confirmed with the local building official or a licensed professional engineer.

Part I. Procedure to Determine the Design Wind Load

[1.1.] Using the Analytical Method - ASCE 7-05

The procedure to determine Design Wind Load is specified by the American Society of Civil Engineers (ASCE 7-05, Minimum Design Loads for Buildings) and referenced in the International Building Code (IBC) 2006. Please refer to ASCE 7-05 if you have any questions about the definitions or procedures presented in this manual. If your installation is located outside the United States, consult your local Unirac distributor or your local building authority. All calculations use Imperial units.

The wind force analysis is based on ASCE 7-05, Chapter 6. Method 2 (Analytical Procedure). Section 6.5.13 (Design Wind Loads on Open Buildings with Mono sloped, Pitched, or Troughed Roofs). The pressures are determined following Section 6.5.13.2 (Main Wind-Force Resisting System) according to the following formulas:

$$p_D = q_h \times G \times C_{nD} \quad \text{Equation 1}$$

$$p_U = q_h \times G \times C_{nU} \quad \text{Equation 2}$$

where

p_U = Uplift design wind pressure (negative sign denotes force away from the roof) (10psf minimum)

p_D = Downforce design wind pressure (positive sign denotes force toward the roof) (10psf minimum)

q_h = velocity pressure evaluated at mean roof height

G = gust effect factor as determined in ASCE 7-05 Section 6.5.8

C_{nU} = net pressure coefficient for Uplift determined from ASCE 7-05 Fig. 6-18A, p. 66.

C_{nD} = pressure coefficient for Downforce determined from ASCE 7-05 Fig. 6-18A, p. 66

[1.2.] Procedure to Calculate Design Wind Load

The procedure for determining the Design Wind Load can be broken into steps that include looking up several values in different tables.

Step 1: Determine Basic Wind Speed, V (mph)

Determine the Basic Wind Speed, V (mph), by consulting your local building department or locating your installation on the map in Figure 1, p. 4.

Determine the following information:

- Basic Wind Speed, V (mph), the fastest 3 second gust of wind in the last 50 years
- Mean roof height, h (ft)
- Effective Wind Area (ft²) = minimum total continuous area of modules being installed
- Roof Zone = area of the roof you are installing the PV system (see Step 2 below)
- Roof Zone Setback Length, a (ft) (see Step 2 below)
- Roof Pitch (degrees)
- Exposure Category (see Step 4 below).

Step 2: Determine Roof/Wall Zone

The Design Wind Load will vary based on where the installation is located on a roof. RapidRac™ G10 mounting systems may be located in more than one roof zone.

Using Table 1, determine the Roof Zone Setback Length, a (ft), according to the width and height of the building on which you are installing the PV system.

Determine in which roof zone your PV system is located, Zone 1, 2, or 3 according to Figure 2. If the array is located in Zone 2 or 3, please consult a professional engineer.

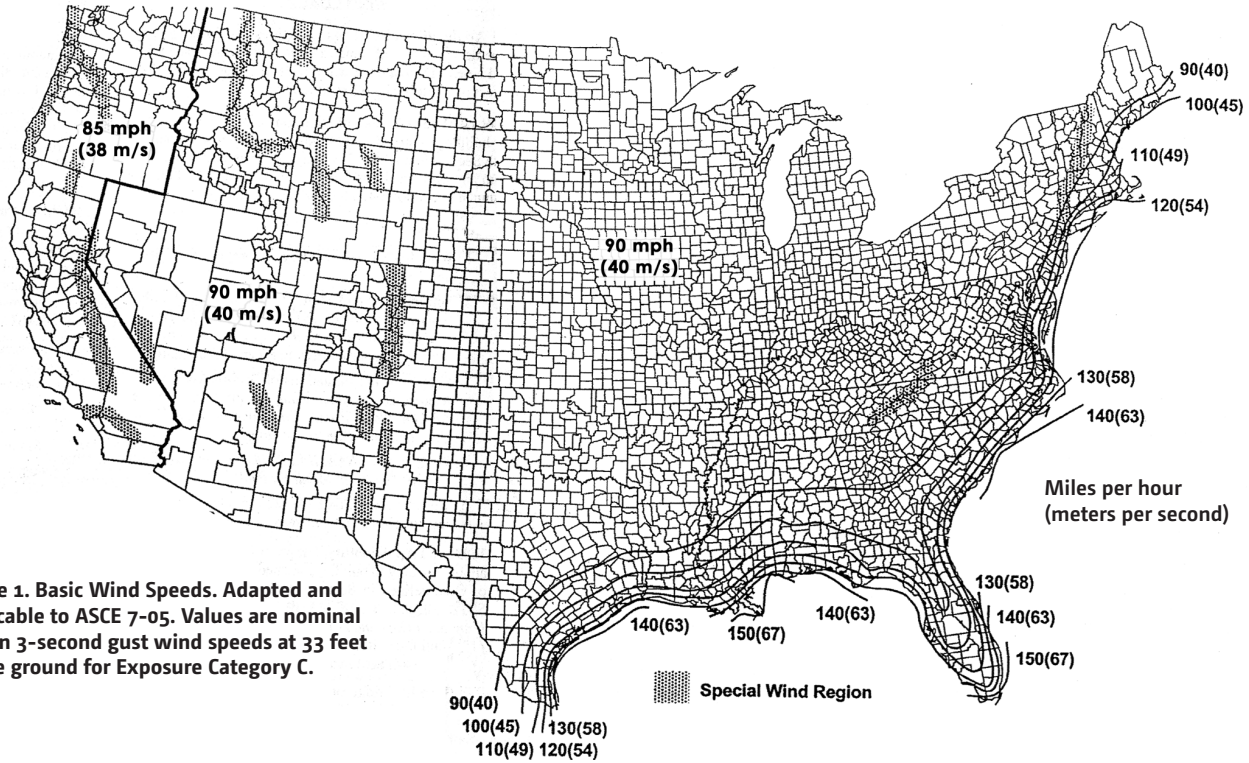

Figure 1. Basic Wind Speeds. Adapted and applicable to ASCE 7-05. Values are nominal design 3-second gust wind speeds at 33 feet above ground for Exposure Category C.

Table 1. Determine the Roof/Wall Zone, length (a) according to building width and height

a = 10 percent of the least horizontal dimension or 0.4h, whichever is smaller, but not less than either 4% of the least horizontal dimension or 3 ft of the building.

Roof Height (ft)	Least Horizontal Dimension (ft)																		
	10	15	20	25	30	40	50	60	70	80	90	100	125	150	175	200	300	400	500
10	3	3	3	3	3	4	4	4	4	4	4	4	5	6	7	8	12	16	20
15	3	3	3	3	3	4	5	6	6	6	6	6	6	6	7	8	12	16	20
20	3	3	3	3	3	4	5	6	7	8	8	8	8	8	8	8	12	16	20
25	3	3	3	3	3	4	5	6	7	8	9	10	10	10	10	10	12	16	20
30	3	3	3	3	3	4	5	6	7	8	9	10	12	12	12	12	12	16	20
35	3	3	3	3	3	4	5	6	7	8	9	10	12.5	14	14	14	14	16	20
40	3	3	3	3	3	4	5	6	7	8	9	10	12.5	15	16	16	16	16	20
45	3	3	3	3	3	4	5	6	7	8	9	10	12.5	15	17.5	18	18	18	20
50	3	3	3	3	3	4	5	6	7	8	9	10	12.5	15	17.5	20	20	20	20
60	3	3	3	3	3	4	5	6	7	8	9	10	12.5	15	17.5	20	24	24	24

Source: ASCE/SEI 7-05, Minimum Design Loads for Buildings and Other Structures, Chapter 6, Figure 6-3, p. 41.

Figure 2. Enclosed buildings, wall and roofs

Flat Roof

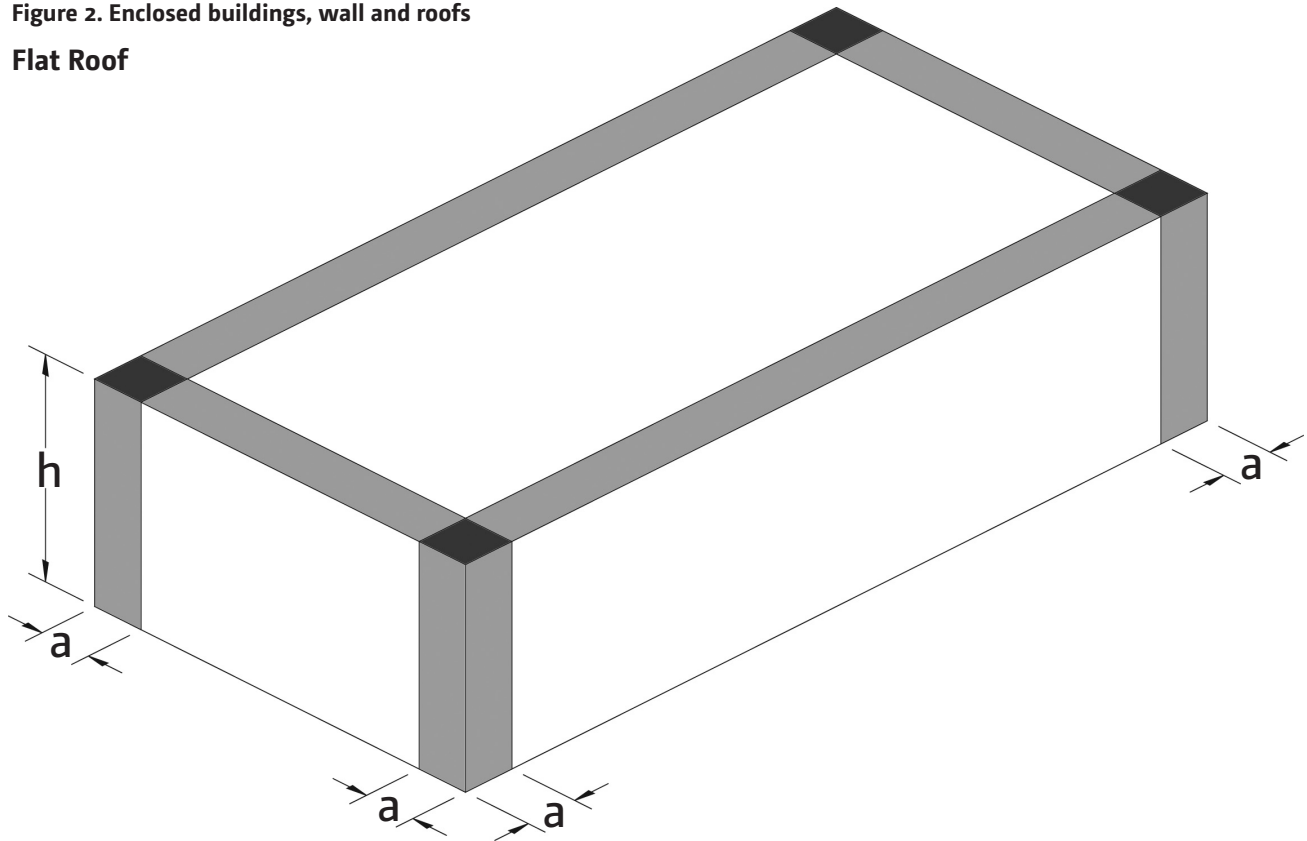

Source: ASCE/SEI 7-05, Minimum Design Loads for Buildings and Other Structures, Chapter 6, p. 41.

Step 3: Determine the Topographic Factor, K_{zt}

The installation is assumed to be on level ground (less than 10% slope), resulting in the Topographic Factor, K_{zt} , equal to 1. If the installation is not on level ground, consult ASCE 7-05, Section 6.5.7 and a professional engineer to determine the Topographic Factor.

Step 4: Determine Exposure Category (B, C, D)

Determine the Exposure Category by using the following definitions for Exposure Categories.

EXPOSURE B is urban and suburban areas, wooded areas, or other terrain with numerous closely spaced obstructions having the size of single family dwellings.

EXPOSURE C has open terrain with scattered obstructions having heights generally less than 30 feet. This category includes flat open country, grasslands, and all water surfaces in hurricane prone regions.

EXPOSURE D has flat, unobstructed areas and water surfaces outside hurricane prone regions. This category includes smooth mud flats, salt flats, and unbroken ice.

Also see ASCE 7-05 pages 287-291 for further explanation and explanatory photographs, and confirm your selection with the local building authority.

Step 5: Determine the Adjustment Factor for Building Height and Exposure Category, K_z

Determine K_z from the table below based on the exposure category and building height.

Table 1. Velocity Pressure Exposure Coefficient, K_z

Height above ground level, h ft.	Exposure Category		
	B	C	D
15	0.57	0.85	1.03
20	0.62	0.9	1.08
25	0.66	0.94	1.12
30	0.7	0.98	1.16
40	0.76	1.04	1.22
50	0.81	1.09	1.27
60	0.85	1.13	1.31
70	0.89	1.17	1.34
80	0.93	1.21	1.38
90	0.96	1.24	1.4
100	0.99	1.26	1.43
120	1.04	1.31	1.48
140	1.09	1.36	1.52
160	1.17	1.39	1.55
180	1.19	1.43	1.58
200	1.2	1.46	1.61
250	1.28	1.53	1.68
300	1.35	1.59	1.73
350	1.41	1.64	1.78
400	1.47	1.69	1.82
450	1.52	1.73	1.86
500	1.56	1.77	1.89

Step 6: Determine Wind Directionality Factor, K_d

The wind directionality factor, K_d , is 0.85 according to ASCE 7-05 Table 6-4, pg. 80.

Step 7: Determine the Importance Factor, I

The importance factor, I , is determined to be 0.87, according to ASCE 7-05, Table 6-1, p. 77, using the building category found in Table 1-1, p. 3.

Step 8: Calculate the Velocity Pressure due to Wind, q_h

From Chapter 6 of ASCE 7-05, Section 6.5.10, the velocity pressure due to wind, q_h , is calculated as follows:

$$q_h = 0.00256 \times K_z \times K_{zt} \times K_d \times V^2 \times I \quad \text{Equation 3}$$

where

K_z = Adjustment Factor for Building Height and Exposure Category

K_{zt} = Topographic Factor = 1

K_d = Directionality Factor

I = Importance Factor.

With the factors that are always constant accounted for, velocity pressure, q_h is determined as follows:

$$q_h = 0.0019 \times K_z \times V^2 \quad \text{Equation 4}$$

Step 9: Determine the Gust Effect Factor, G

The gust factor, G , is determined to equal 0.85, according to ASCE 7-05 Section 6.5.8.1, and using the structure definition from ASCE 7-05, Section 6-2.

Step 10: Determine the Net Pressure Coefficients, C_{nU} and C_{nD}

From Equation 1, the net pressure coefficients, C_{nU} and C_{nD} , can be determined from ASCE 7-05 Fig. 6-18A, p. 66. The C_n values are based on clear wind flow as wind tunnel tests have determined for the RapidRac™ G10. As RapidRac™ G10 is available at a fixed tilt angle of 10 degrees, the pressure coefficients calculated are the linearly interpolated values between 7.5 and 15 degrees. Performing the calculations, the maximum uplift and the maximum down force are, respectively:

$$C_{nU} = (-0.9)$$

$$C_{nD} = (1.28)$$

The C_n values are from ASCE 7-05, Figure 6-18D (wind force in the X-direction will not control).

Step 11: Calculate the Design Wind Loads, p_D and p_U (psf)

Multiply the Velocity Pressure at mean roof height, q_h , in Step 8 by the Gust Effect Factor in step 9 and the Net Pressure Coefficient in step 10 using the following equations. Note that 10 psf is always used as a minimum:

$$P_D = q_h \times G \times C_{nD} \quad \text{Equation 1}$$

$$P_U = q_h \times G \times C_{nU} \quad \text{Equation 2}$$

The resultant Design Wind Loads will be used in Part II to select the appropriate ballast.

Part II. Load Forces on RapidRac™ G10 Mounting System

Step 1: Calculate Wind Load Forces

For purposes of this analysis the Uplift and Downforce Design Wind Loads are respectively:

- pU = Uplift Design Wind Load (psf)
- pD = Downforce Design Wind Load (psf)

Apply Wind Load to the photovoltaic module area to calculate Wind Load Force per module in uplift and downforce cases.

$$WLFU = \text{Module Area} \times pU \text{ (negative value per the sign convention)} \quad \text{Equation 5}$$

$$WLFD = \text{Module Area} \times pD \text{ (positive value per the sign convention)} \quad \text{Equation 6}$$

These forces can then be calculated as follows:

$$WLFUz = \text{Uplift Wind Load Force in Z direction} = WLFU \times \text{COS}(10^\circ) \quad \text{Equation 7}$$

$$WLFUy = \text{Uplift Wind Load Force in Y Direction (or Drag)} = WLFU \times \text{SIN}(10^\circ) \quad \text{Equation 8}$$

$$WLFDz = \text{Downforce Wind Load Force in Z Direction} = WLFD \times \text{COS}(10^\circ) \quad \text{Equation 9}$$

$$WLFDy = \text{Downforce Wind Load Force in Y Direction} = WLFD \times \text{SIN}(10^\circ) \quad \text{Equation 10}$$

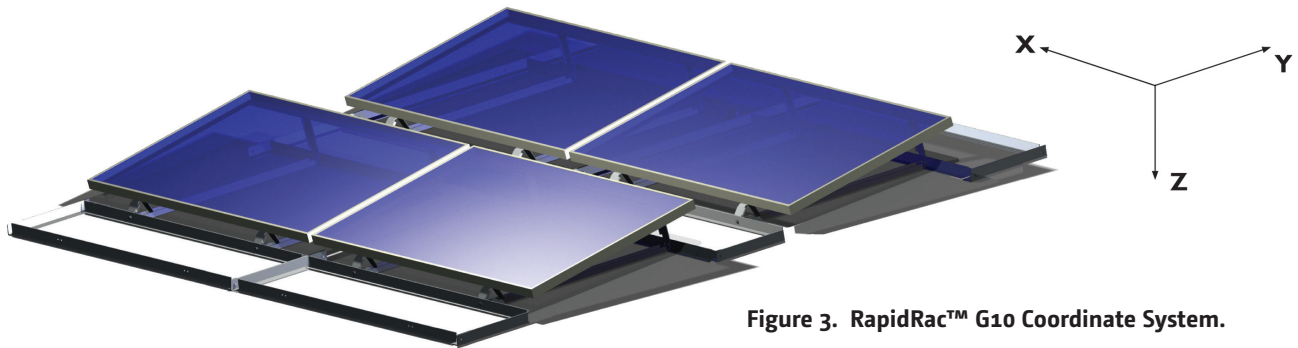

Figure 3. RapidRac™ G10 Coordinate System.

Step 2. Calculate Snow Load

Chapter 7 of ASCE 7-05 addresses snow loading and is used to determine snow loading forces on the RapidRac™ G10 structure.

Snow loads act on the horizontal projection of the photovoltaic module onto the roof.

$$SLr = SL_g \times \text{COS}(10^\circ) \quad \text{Equation 11}$$

where

SL_g = Ground Snow Load in the downward direction.

To determine the Snow Load Force per module, SL_{Fr} (lbs), multiply the Roof Snow Load, SL_r (psf) by the photovoltaic module area (sf).

$$SLFr = SL_r \times \text{Module Area} \quad \text{Equation 12}$$

Step 3. Apply Load Combinations

From Chapter 2 of ASCE 7-05, section 2.4.1, several load combinations must be considered in the development of the maximum design forces. These forces will be used to determine the structural requirements of RapidRac as well as the required amount of ballast. The Load Combination Forces are calculated below on a per module basis.

Load Combination 1, $LC1 = dLF1 + SLF_r$ **Equation 13**

Load Combination 2, $LC2 = dLF1 + WLF_{Dz}$ **Equation 14**

Load Combination 3, $LC3 = dLF1 + (0.75 \times SLF_r) + (0.75 WLF_{Dz})$ **Equation 15**

Load Combination 4, $LC4 = (0.6 \times dLF1) + WLF_{Uz}$ **Equation 16**

where

dLF1 = Dead Load Force 1 (the weight of the photovoltaic modules and the racking materials divided by the overall array area) module area

SLF_r = Roof Snow Load Force per module

WLF_{Dz} = Downforce Wind Load Force in Z direction per module

WLF_{Uz} = Uplift Wind Load Force in Z direction per module

Dead Load Force 1, dLF1, does not include weight from the ballast blocks per module

Step 3.1 Z Direction Load Combination, Downforce

To calculate the downforce on the RapidRac™ G10 structure, the Downforce Wind Load Force in Z direction (WLF_{Dz}) is applied in the Load Force Combination equations LC1, LC2, and LC3 above.

The design downforce is taken from the maximum value calculated from the Load Combination equations. This will be called the Downforce Design Load Force in Z direction, DLF_{Dz} .

Z direction loads are applied to RapidRac™ G10 racking system through the front and rear brackets (2 each per module). The RapidRac™ G10 system has only one configuration. Module brackets are located symmetrically in both x and y axis.

DLF_{Dz} = Downforce Design Load Force in Z direction (maximum of LC1, LC2, or LC3)

Each module is supported by four brackets. The resulting allowable force is:

$DLF_{Dz} / 4$ = Downforce Design Load Force in each RapidRac G10 Module Bracket in Z direction

$DLF_{Dz} / 4 < 400$ lbs (rear bracket allowable compression force from testing)

Step 3.2 Z Direction Load Combination, Uplift

To determine the uplift wind load in Z direction (DLF_{Uz}), Load Combination 4, LC4, must be used as this is the only load combination with uplifting components.

DLF_{Uz} = Uplift Design Load Force in Z direction = LC4

Since each module is supported by four brackets, the resulting allowable force is:

$DLF_{Uz} / 4$ = Uplift Design Load Force in each RapidRac™ G10 Module Bracket in Z direction

$DLF_{Uz} / 4 < 620$ lbs (rear bracket allowable tensile force from allowable bolt shear published value)

Step 3.3 Y Direction Load Combinations

Load combinations do not apply in x or y directions for downforce or uplift. Forces in the X direction are forces expected from a seismic event. Forces in the Y direction are forces expected from a seismic event and along with drag forces, (defined earlier in Part II, Step 1).

Y direction loads are applied to the RapidRac™ G10 racking system through the front and rear brackets (2 each per module). The RapidRac™ system has only one configuration. Module brackets are located symmetrically in both x and y axis.

DLF_{Dy} = Downforce Design Load Force in Y direction (shear force in module bracket upper connection points)

DLF_{Uy} = Uplift Design Load Force in Y direction (bracket tensile force)

Each module has 2 upper connection points. The resultant allowable force from the downforce is:

$DLF_{Dy} / 2 < 1034$ lbs. (2X bolt shear in upper connection)

Each module is supported by two brackets, the resulting allowable force from uplift is:

$DLF_{Uy} / 2 < 1034$ lbs (front bracket allowable tensile force from bolt tensile force published value)

Step 3.4 X Direction Load Combinations

Forces in the X direction will not control for wind and snow loads. Seismic Loads will control in this direction. Use the following Seismic Load Combination:

Load Combination 5, $LC5 = dLF2 + (0.7 \times E)$ **Equation 17**

where

dLF2 = Dead Load Force Realized by Substructure (includes ballast and is calculated in Step 6)

E = Seismic Load Coefficient (calculated in Step 6).

This load combination will be used after calculating the required amount of ballast and, if necessary, number of attachments due to wind.

Step 4. Determine Ballast Requirements due to Uplift Wind Forces

RapidRac G10 is designed to be a ballasted roof mount system. Ballast blocks are used to weigh down the array to counteract wind forces in the Z and Y direction. To determine the amount of required ballast both uplift in the Z direction and drag in the Y direction must be considered.

Ballast Weight Requirements per Module in the Z Direction.

The ballast weight requirement per module in the Z Direction, BW_{Uz} , is equal to Load Combination 4, LC4, or DLF_{Uz} , from Step 3.2.

This ballast value applies to all modules located in roof zone 1. For any modules that are positioned in roof zone 2 or 3, the appropriate roof zone factor from the Components and Cladding section of the code (ASCE 7-05, 6.4) must be applied to the ballast requirements in those zones respectively.

Ballast Weight Requirements per Module in the Y Direction (Drag Forces)

The uplift wind force condition will control in all cases in the Y Direction. The normal force due to the sum of Dead Load Force 1, $dLF1$, plus the difference between the Ballast Weight Requirement per module in the Z Direction, BW_{Uz} and DLF_{Uz} , if any, multiplied by the assumed coefficient of friction must resist the uplift wind force in the Y Direction, DLF_{Uy} . Following the prescribed method for load combinations in ASCE 7-05, the Dead Load Force 1, $dLF1$, must first be multiplied by a factor of 0.6.

$$BW_{Uy} = (0.6 \times dLF1 + BW_{Uz} + DLF_{Uz}) \times 0.4 \quad \text{Equation 18}$$

where

BW_{Uy} = ballast weight required to resist frictional force of DLF_{Uy}

BW_{Uz} = ballast weight required to resist uplift from wind (DFL_{Uz})

The Code Calculated Ballast Weight Requirement per module is the sum of the Ballast Weight Requirement per module in the Z Direction, BW_{Uz} , and the Ballast Weight Requirement per module to overcome drag, BW_{drag} .

If DLF_{Uy} is greater than BW_{Uy} , then

$$BW_{drag} = (DLF_{Uy} - BW_{Uy}) / 0.4 \quad \text{Equation 19}$$

If DLF_{Uy} is less than BW_{Uy} , then BW_{drag} is zero. Then,

$$BW_c = BW_{Uz} + BW_{drag} \quad \text{Equation 20}$$

where

BW_c = code calculated ballast weight requirement per module

BW_{drag} = ballast weight requirement per module to overcome drag

The result of the Code Calculated Number of Ballast Blocks per module must be adjusted based on the extensive wind tunnel testing completed by Unirac. The adjustment factor to correlate the Code Calculations to the wind tunnel results is 0.434. Multiply the Code Calculated Ballast Weight Requirement per Module by the Wind Tunnel Adjustment Factor yields the Ballast Weight Requirement per module at equilibrium, BW_e .

$$0.434BW_c = BW_e \quad \text{Equation 21}$$

The Ballast Weight Requirement per module at equilibrium must be multiplied by the Factor of Safety, 1.5

$$1.5BW_e = BW_r \quad \text{Equation 22}$$

Calculate the Number of Ballast Blocks per Module

The number of ballast blocks per module equals the sum of the Ballast Weight Requirement per module in the Z Direction and the extra Ballast Weight Requirement to resist forces due to drag divided by the weight per block.

Unirac has designed RapidRac G10 to accept standard “Cap Blocks” with the dimensions of 4” X8” X 16” and having a weight of 26 lb. RapidRac G10 ballast requirements assume the use of these blocks for ballast.

$$(BW_{Uz} + BW_{drag}) / 26 = \text{ASCE 7-05 Code Calculated Number of Ballast Blocks per Module} \quad \text{Equation 23}$$

The number of ballast blocks per module to resist uplift must be rounded up to the nearest quarter block. The average number of ballast blocks per module must be distributed over four ballast frames.

Example: Average # Ballast Blocks= 3.75

Place 4 blocks in 3 ballast frames. Place 3 blocks in the 4th ballast frame. The average number of ballast blocks equals 3.75.

Please note that the recommended number of ballast blocks per module must be kept to a size not in excess of what the ballast tray can hold. RapidRac G10 ballast blocks are intended to be positioned on their 8” x 16” side, in two layers to eliminate shading on the photovoltaic modules. RapidFoot Attachments can be added in order to reduce ballast requirements. Refer to Step 8 on the affect of attachments on ballast requirements for more information.

Step 5. Calculate Dead Load Realized by Substructure

The dead load realized by the substructure is the dead load of the racking and modules and the total ballast required distributed over the entire foot print of the array.

$$A_a = (A_{EW} \times A_{NS}) / 144 \quad \text{Equation 24}$$

$$DL2 = (DLF1 + BW) / a_a \quad \text{Equation 25}$$

where

- A_a = overall array area (sf)
- A_{EW} = overall array East to West dimension (in)
- A_{NS} = overall array North to South dimension (in)
- DL_2 = dead load realized by substructure (psf)
- DLF_1 = average dead Load Force One = weight of modules and racking (lbs)
- BW = total ballast weight (lbs)

Step 6. Calculate Seismic Load

If you are installing the RapidRac™ G10 system in a seismic zone, Unirac recommends a positive attachment to the roof structure. The seismic attachment recommendations use calculations from ASCE 7-05, Chapter 15- “Seismic Design Requirements for Non-Building Structures”. Please note the following calculations used in this manual are conservative in most cases. Please consult with a local professional engineer to determine the applicability of this section of the manual for your installation.

Seismic resistance calculations are based on ASCE 7-05, Chapter 15, Section 15.1.3, which refers to ASCE 7-05 Chapter 12, Section 12.8- the “Equivalent Lateral Force Procedure”, used in this manual. Equation 12.8-1 from this chapter of ASCE 7-05 defines the “Seismic Base Shear”:

$$V_{SBS} = C_s \times W_s \quad \text{Equation 26 (ASCE 7-05, 12.8-1)}$$

where

- V_{SBS} (lbf) = Seismic Base Shear
- C_s = the seismic response coefficient (ASCE 7-05, Section 12.8.1.1)
- W_s = the effective seismic weight (ASCE 7-05, Section 12.7.2)

Per ASCE 7-05, Section 12.8.1.1:

$$C_s = S_{DS} / (R / I_s) \quad \text{Equation 27 (ASCE 7-05, 12.8-2)}$$

where

- S_{DS} = the design spectral response acceleration parameter in the short period range as determined from ASCE 7-05, Section 11.4.4
- R = the response modification factor in ASCE 7-05, Table 12.2-1
- I_s = the importance factor for seismic determined in accordance with ASCE 7-05, Section 11.5.1

Per ASCE 7-05, Section 11.4.4:

$$S_{DS} = (2 / 3) \times S_{MS} \quad \text{Equation 28 (ASCE 7-05, 11.4-3)}$$

where

- S_{MS} = the Maximum Considered Earthquake (MCE), 5% damped, spectral response acceleration parameter at a period of 1 second as defined in ASCE 7-05, Section 11.4.3

Per ASCE 7-05, Section 11.4.3:

$$S_{MS} = F_a \times S_s \quad \text{Equation 29 (ASCE 7-05, 11.4-1)}$$

where

- F_a = a site coefficient (ASCE 7-05, Table 11.4-1)
- S_s = the mapped MCE spectral response acceleration at short periods as determined in accordance with ASCE 7-05, Section 11.4.1

To determine S_s , ASCE 7-05, Figs. 22-1 through 22-14 must be consulted. These tables give the “MCE Ground Motion” by region as a factor of g 's (gravitational acceleration). Upon examination of these figures it can be seen that even for earthquake prone regions, with very few exceptions, an S_s of 2.0 is equal to or greater than the S_s related to almost all possible locations. Unirac’s RapidRac™ G10 Ballasted System seismic attachment requirements are based on using a S_s of 2.0. If it is desired to use a more precise S_s for your location, ASCE 7-05 figures can be used to determine the S_s is for the installation site.

Using S_s of 2.0, the site coefficient F_a , can be determined from ASCE 7-05, Chapter 11, Table 11.4-1, determining a site class. Using ASCE 7-05, Chapter 11, Section 11.4.2, site class is determined by the soil properties of the particular installation site. Note that Section 11.4.2 states “Where the soil properties are not known in sufficient detail to determine the site class, Site Class D shall be used unless the authority having jurisdiction on geotechnical data determines Site Class E or F soils are present at the site”. Site Class D is used for these seismic calculations. Consult a local engineer if you would like to determine your actual Site Class.

Using an S_s of 2.0 and a Site Class of D in Table 11.4-1, F_a equals 1.0. Substituting these values in Equation 29 provides the following:

$$S_{MS} = F_a \times S_s = 2.0 \times 1.0 = 2.0. \quad \text{Equation 29}$$

Substituting into Equation 28 provides the following:

$$S_{DS} = (2 / 3) \times S_{MS} = 1.33. \quad \text{Equation 28}$$

For the seismic response coefficient (Equation 27): $C_s = S_{DS} / (R / I_s)$, the values for R and I_s are needed. As noted previously, R equals the response modification factor in ASCE 7-05, Table 12.2-1. Upon review of Table 12.2-1, the closest description to the RapidRac™ G10 Racking System is case H: “Steel Systems Not Specifically Detailed for Seismic Resistance Excluding Cantilever Column Systems”. Though RapidRac™ G10 is not a steel structure, this is the closest representation of RapidRac™ G10, and using Case H yields a relatively conservative value for the Response Modification Factor. Therefore $R = 3$ from Table 12.2-1.

The occupancy importance factor (for seismic considerations), I_s , is determined in accordance with ASCE 7-05, Section 11.5.1 and Table 1-1. The best description of the RapidRac™ G10 structure falls into Occupancy Category II. Using this value in Table 11.5-1, I_s equals 1.0.

Solving for equation 27,

$$C_s = S_{DS} / (R / I_s) = 1.33 / (3 / 1.0) = 0.443. \quad \text{Equation 27}$$

Determining the seismic base shear (equation 12.8-1) requires the effective seismic weight W ; (ASCE 7-05, Section 12.7.2). From Section 12.7.2, the total dead load of the array is all that must be considered, therefore DL_2 equals the total dead load calculated in Step 5 above. Substituting into equation 26:

$$V_{SBS} = C_s \times W = 0.443 \times W \quad \text{Equation 26}$$

Using a factor of safety of 1.5, seismic resistance force is determined by the following equation:

$$E = 0.443 \times DL_2 \quad \text{Equation 30}$$

where

E = The effect of earthquake induced forces

Step 7. RapidFoot Attachment Requirements due to Forces in X Direction

$$\text{The number of RapidFoot attachments} = LC_5 / ASF_{RF} \quad \text{Equation 31}$$

where

ASF_{RF} = Allowable Shear Force resisted by RapidFoot attachment

LC_5 = Load Combination 5

Step 8. Affect of Attachments on Ballast Requirements

Ballast can be reduced by adding attachments. RapidFoot attachments have an allowable uplift design load Force in the Z direction of 1200 lbs.

$$RF_{Uz} = \text{number of RapidFoot attachments} \times 1200 \text{ lbs.}$$

$$BW_{Tr} = BW_T - RF_{Uz}$$

$$BW_m = BW_{Tr, \text{ total}} / \text{number of modules.}$$

where

RF_{Uz} = total uplift force resisted by RapidFeet

BW_T = Total ballast weight

BW_{Tr} = revised Total ballast weight

BW_m , = the revised ballast weight requirement per module

The Revised Ballast Weight Requirement per module must be rounded up to the nearest quarter block and distributed in the same manner described in Step 4.

Return to Step 3.4 X Direction Load Combination and complete it.

Step 8. Location for RapidFoot Attachment with Respect to Wind Load and Seismic Load Forces in the X and Y Directions

The placement of RapidFoot attachments with regard to connection strength is an important consideration. Each ballast frame can resist a maximum allowable uplift force of 1240 lbs.

The local uplift design load force in the Z Direction per module, $LDLF_{Uz}$, must be less than the allowable uplift force per ballast frame, AUF_{bf} , and the allowable uplift force of RapidFoot. The following inequality will determine the placement of RapidFoot Attachments.

$$AUF_{bf} \times \text{Number of Modules per RapidFoot attachment} < 1200 \text{ lbs}$$

The controlling design consideration for the location of RapidFoot attachments with respect to wind load is the wind load forces in the Z direction.

The maximum allowable uplift load force in the Z Direction is 1240 lbs with respect to the ballast frame to rail bracket attachment. The maximum allowable uplift force in the Z direction for RapidFoot is 1200 lbs. The RapidFoot attachment is the controlling condition.

The allowable lateral load force in the X direction is 1240 lbs with respect to the ballast frame to rail bracket attachment. The allowable lateral load force in the X and Y directions for RapidFoot is 1200 lbs. The RapidFoot attachment will be the controlling condition.

Location of RapidFoot attachments shall be specified by a licensed design professional using the following guidelines:

1. The tributary load due Seismic or Uplift Wind Load Force must be less than 1200 lbs.
2. Locate RapidFoot Attachments symmetrically about the x and y axis.
3. Locate RapidFoot Attachments at the perimeter of the array.
4. For arrays that have greater than 3 modules in the x or y direction, one RapidFoot must be located toward each corner of the array, while also observing Guidelines 1, 2, and 3.
5. For irregularly shaped arrays, locate one RapidFoot at the end of each appendage, observing Guidelines 1, 2, 3, and 4.

Part III. Ballast Distribution Requirements

Step 1. Distribution of Ballast Blocks over the Array

Unirac has designed the RapidRac™ G10 system to take advantage of the large array wind effect, which lightens the overall ballast requirements while remaining strong and safe in the areas most effected by the wind. The areas that see the highest lift due to winds are the east, north, and west perimeters of any array. For this reason, Unirac recommends ballast distribution that is biased towards these three perimeters. Ballast distribution for the RapidRac™ G10 system is specified such that the entire arrays ballast is determined and the average number of ballast blocks is calculated for each module in the array. This number is then multiplied by a factor of 1.5 for the east, north, and west perimeter modules (rounded up to the next whole block). The remaining blocks are then distributed evenly between the remaining interior modules.

These examples presume that no modules are located in roof zones 2 or 3. If modules were located in those roof zones, the appropriate “External Pressure Coefficients” as defined in ASCE 7-05, Fig. 6-17 would need to be applied to the modules in those zones respectively. The resulting ballast requirements would then be met with either the addition of ballast blocks or the use of an attachment allowance using the RapidFoot attachment method outlined in the RapidFoot Installation Manual.

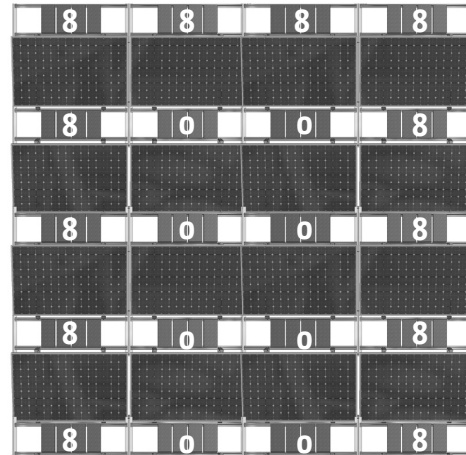

Example 1: 4 by 4 module array with 4 wide by 5 deep bay frames

For the purposes of illustration, consider that the array wind calculations determine that this array requires an average of five ballast blocks per module. The total number of ballast blocks for this array would be $16 \times 5 = 80$. Eighty ballast blocks would ensure the appropriate safety factor and that the array would be secure on the roof. The first step in distributing the ballast would be to apply 8 ballast blocks ($5 \times 1.5 = 7.5$ rounded to 8) to the 5 east, 4 north and 5 west perimeter ballast frames. This is a total of 96 ballast blocks. Even though this exceeds the total for the array, the methodology should hold. The final result is: 8 ballast blocks in each of 12 perimeter bay frames and 0 in each of 8 interior bay frames.

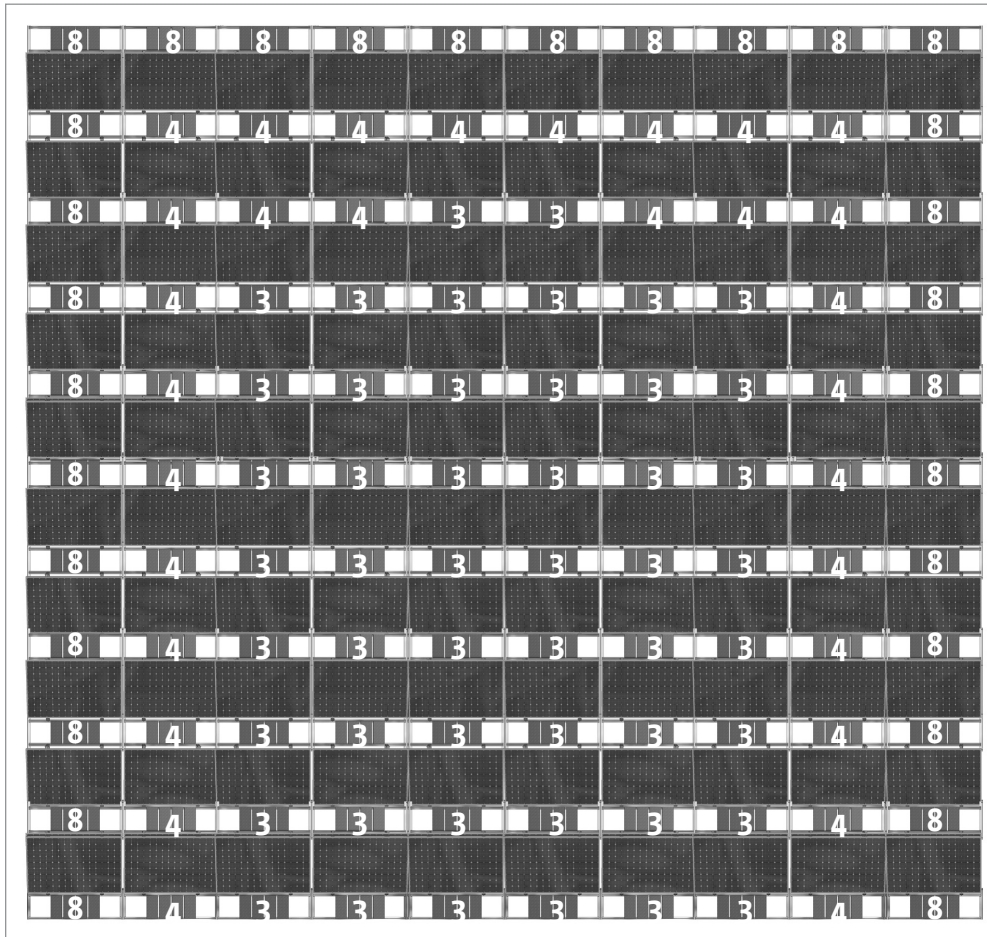

Example 2: 10 by 10 array with 10 wide by 11 deep ballast frames.

For the purposes of illustration, use the same average of five ballast blocks per module as in example 2. The total number of ballast blocks for this array would be $100 \times 5 = 500$. The first step in distributing the ballast would be to apply 8 ballast blocks ($5 \times 1.5 = 7.5$ rounded to 8) to the 10 east, 10 north and 10 west perimeter bay frames. This is a total of 240 ballast blocks leaving a balance of 260 ballast blocks for the remaining 80 interior bay frames with 20 bay frames having 4 blocks and 60 bay frames having 3 blocks. The interior ballast blocks should be distributed in a concentric ring pattern as shown.

[3.] Assembly

Step 1

Lay bay frames on roof where array will be installed. Connect bay frames using bolts, washers and flange nuts. Consult page 16 of this manual for proper uses of WEEB 9.5

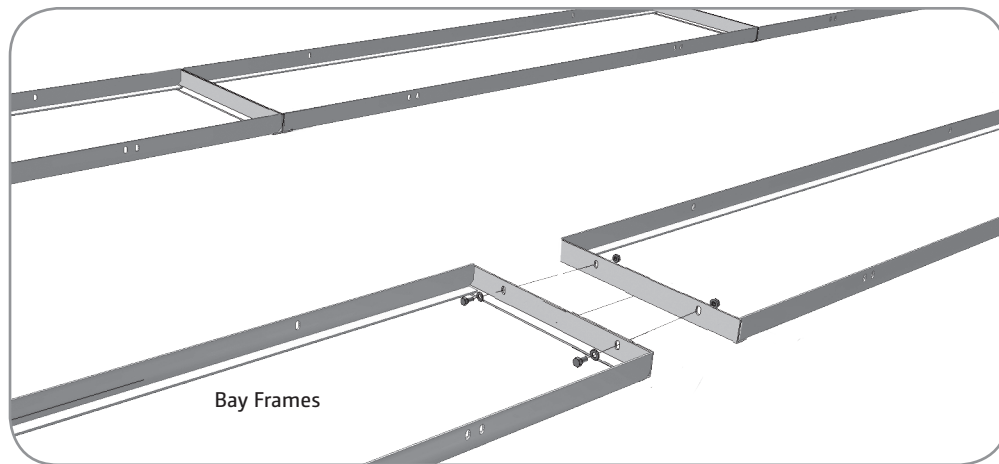

Step 2

Attach 2 module brackets to each module using hex bolts, washers and flange nuts on all four connections points, using WEEB 9.5 on frame holes facing in towards the array.

Note: Make sure to use a piece of cardboard to protect the module from the surface of the roof.

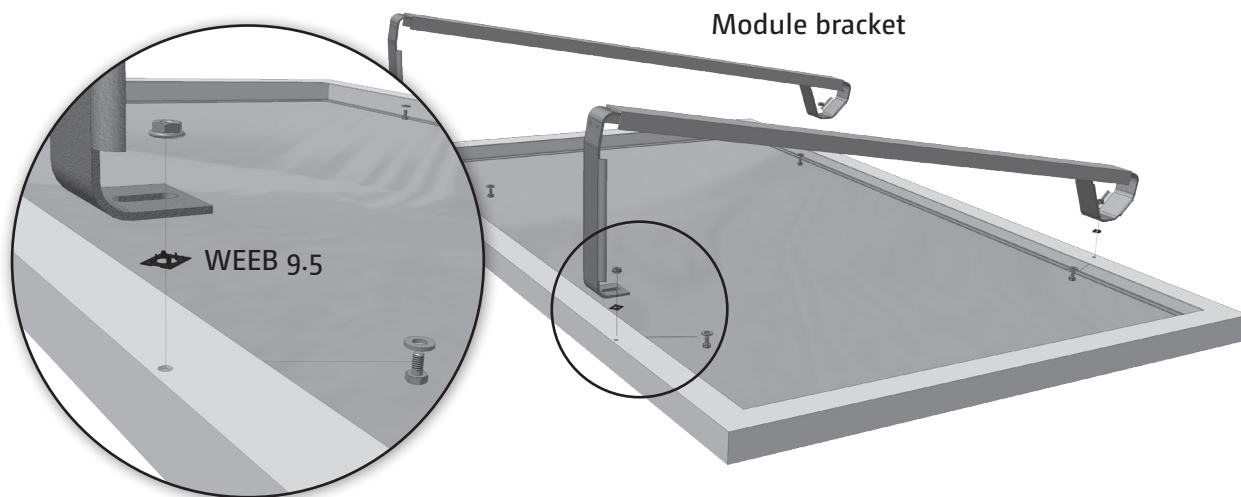

Part IV. Installing RapidRac™ G10

[1.] Tools required for assembly



7/16 Wrench

[2.] Components list

- 1 **Bay frame** – Module mounting frame for all modules south of north most row. 6105-T5 aluminum extrusion.
- 2 **Module bracket** – (No. 10 x 3/4") – Used to secure module to bay frame. 10° tilt angle. 6105-T5 aluminum extrusion. Integral PEM nuts for quick assembly
- 3 **Hex Bolt** (1/4" x 3/4") – Use with all components of RapidRac™. 304 stainless steel.
- 4 **Flat Washer** (5/16") – Use with all components of RapidRac™. 304 stainless steel.
- 5 **Serrated Flange nut** (1/4") – Use one per hex bolt and washer during assembly. 302 stainless steel. Required torque: 5 foot-pounds.
- 6 **WEEB 9.5** – Use with hex bolt and washer during assembly on frame holes facing in towards the array. 302 stainless steel.

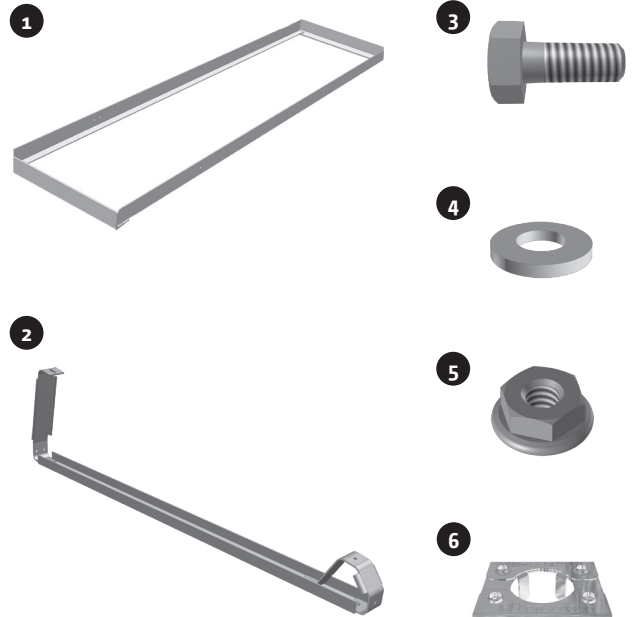

Step 3

Lower module with module brackets between rows of bay frames. Connect using hex bolts and washers on all six connections points. Pressed nuts have been attached to the inside of brackets to speed installation.



Step 4

Ballast requirements vary. Total amount of concrete blocks placed in frame depends on wind speed, exposure, building height and module dimensions.

Parts provided by installer:

Solid Cap Concrete Blocks
(4" x 8" x 16"), 26 lbs.

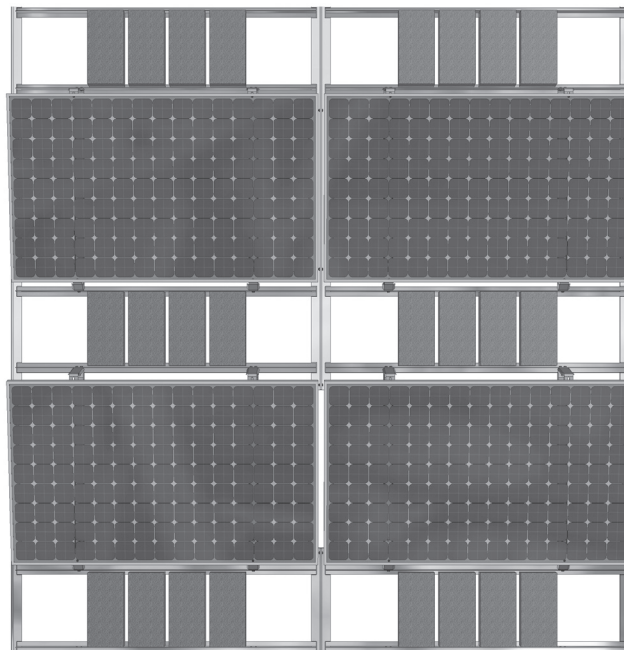

Note: Unirac requires that all perimeter ballast blocks be adhered to the bay with Subfloor construction adhesive (BC-490 or equal).

WEEB 9.5 Grounding

RapidRac is sold with a grounding solution. UniRac utilizes a WEEB 9.5 grounding clip to ground the modules to the RapidRac frame, and the individual frames to each other. The WEEB 9.5 clips are inserted into the RapidRac frame holes with the prongs facing in towards the rack. The module is then placed down on top of the clips and the fastener is used to secure the module to the bracket frames. WEEB 9.5's are also inserted into the holes that interconnect the bay frames as shown. With all WEEB's in place and all fasteners torqued appropriately, the entire array and all modules are grounded and a single ground can be run for the array as appropriate building code requirements.

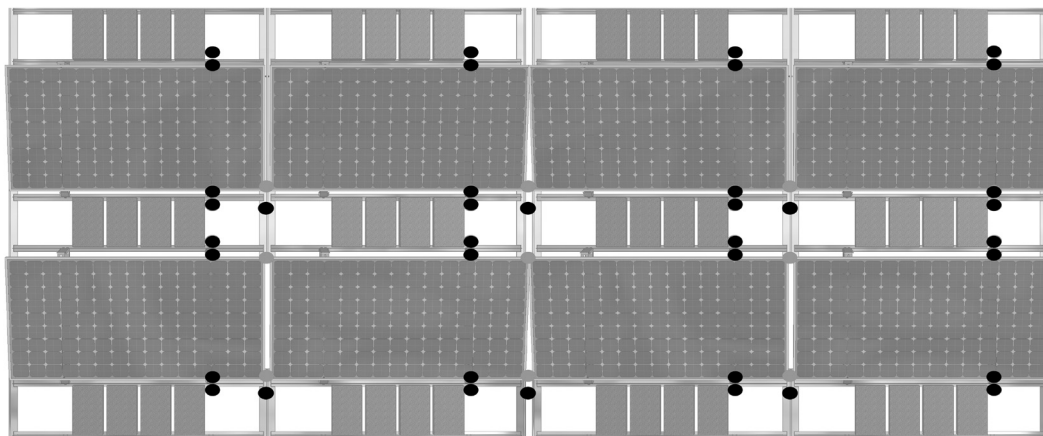
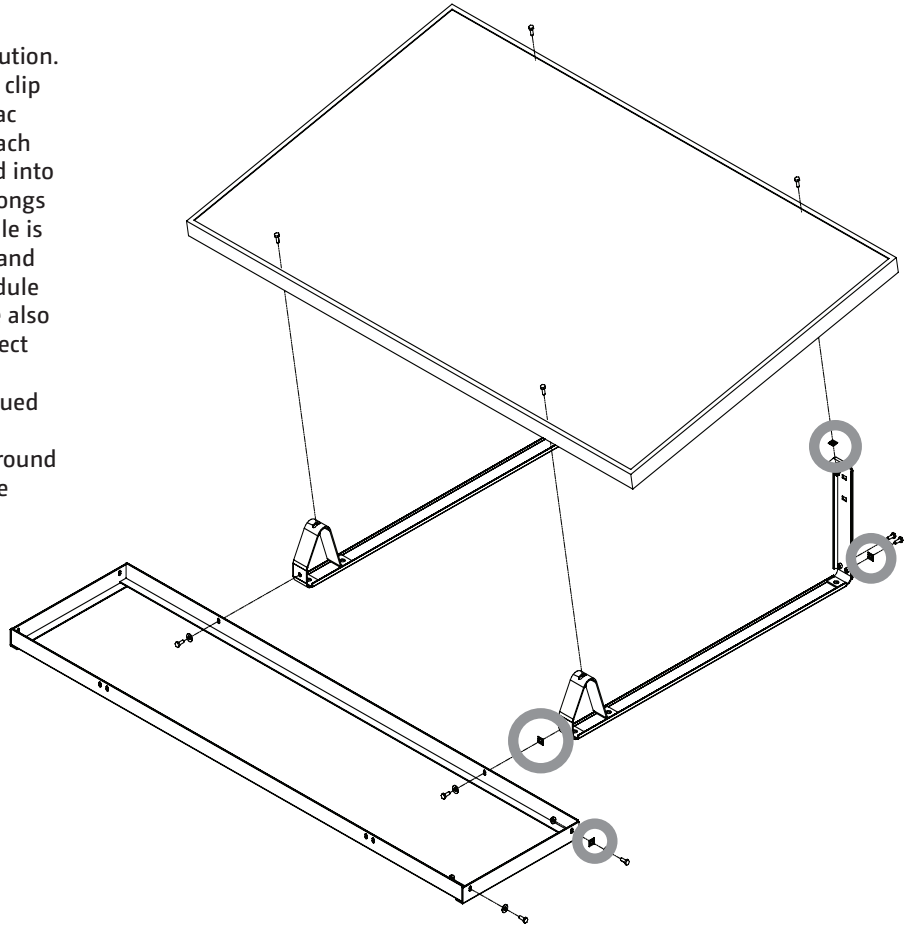

Figure 4. An example of where WEEB 9.5 grounding clips would be positioned to ground an array.

Part V. Appendix

Appendix A - Variable Definition

variable	definition	units
V	Basic Wind Speed	mph
h	Building Height	ft
K_z	Adjustment Factor for Building Height and Exposure Category	
K_{zt}	Topographic Factor	
K_d	Directionality Factor	
I	Importance Factor	
q_h	$q_h=0.00256K_zK_{zt}K_dV^2$ velocity pressure at mean roof height	psf
G	Gust Effect Factor	
C_{nU}	Net Pressure Coefficient (uplift)	
C_{nD}	Net pressure Coefficient (downforce)	
p_u	Uplift Design Wind Load (pressure)	psf
p_D	Downforce Design Wind Load	psf
ma	Module Area	sf
A_{ew}	Overall Array E-W Dimension	in
A_{ns}	Overall Array N-S Dimension	in
Aa	Overall Array Area	sf
DLF1	Average Dead Load Force per Module dLF1	lbs
DL1	Average Dead Load One, dL1	psf
WLF_D	Downforce Wind Load Force, WLF_D	lbs
WLF_U	Uplift Wind Load Force, WLF_U	lbs
WLF_{DZ}	Downforce Wind Load Force in Z direction, WLF_{DZ}	lbs
WLF_{UZ}	Uplift Wind Force Load in Z Direction WLF_{UZ}	lbs
WLF_{DY}	Downforce Wind Load Force in Y Direction WLF_{DY}	lbs
$WLF_{UY} = DLF_{UY}$	Uplift Wind Load Force in Y Direction, WLF_{UY}	lbs
SL_g	Ground Snow Load, SL_g	psf
SLF_g	Ground Snow Load Force, SLF_g	lbs
SLF_r	Roof Snow Load Force in Z Direction, SLF_r	lbs
LC1	Load Combination 1, LC1	lbs
LC2	Load Combination 2, LC2	lbs
LC3	Load Combination 3, LC3	lbs
LC4	Load Combination 4, LC4 or Uplift Design Load Force in Z Direction, DLF_{UZ}	lbs
DLF_{DZ}	Downforce Design Load Force in Z Direction, DLF_{DZ} , Maximum Transient Load Force	lbs
$DLF_{UZ} = BW_{UZ}$	Uplift Design Load Force in Z Direction, DLF_{UZ}	lbs
$DLF_{DZ}/4$	Downforce Design Load Force in Z Direction per Module Bracket, $DLF_{DZ}/4$	lbs

Appendix A - Variable Definition

Variable	Definition	Units
ADF_{zmb}	Allowable Uplift Force in Z Direction	lbs
$DLF_{Uz}/4$	Uplift Design Load Force in Z Direction per Module Bracket, $DLF_{Uz}/4$	
AUF_{zmb}	Allowable Uplift Force in Z Direction	lbs
$DLF_{Dy}/2$	Downforce Design Load Force in Y Direction per Module Bracket, $DLF_{Dy}/2$	lbs
ADF_{ymb}	Allowable Downforce Force in Y Direction	lbs
BW _{Uz}	Ballast Weight Requirement per Module for Uplift	lbs
BW _{drag}	Additional Ballast Weight Required from Drag	lbs
BW_c	Code Required Ballast Weight per Module for Uplift and Drag	lbs
BW_e	Ballast Weight Requirement per Module at equilibrium (after applying wind tunnel adjustment)	lbs
BW_r	Recommended Ballast Weight per Module for Uplift and Drag	lbs
BW_{Tr}	Total Resulting Ballast Weight for Uplift and Drag	lbs
AWF_{RF}	Allowable Withdrawal Force for RapidRac Connection in 22 ga steel	lbs
dLF2	Dead Load Force Two dLF2	lbs
E	Seismic Load Force Coefficient, E	lbs
LC5	Load Combination 5, LC5, in X and Y Directions	lbs
ASF_{RF}	Allowable Shear Force for RapidFoot Connection	lbs
V_{SBS}	Seismic Base Shear	lbf
C_s	Seismic Response Coefficient (ASCE 7-05, Section 12.8.1.1)	
W_s	Effective Seismic Weight (ASCE 7-05, Section 12.7.2)	
S_{DS}	Design Spectral Response Acceleration Parameter in the short period range as determined from ASCE 7-05, Section 11.4.4	
R	Response Modification Factor in ASCE 7-05, Table 12.2-1	
I_s	Importance Factor for Seismic Determined in Accordance with ASCE 7-05, Section 11.5.1	
SMS	Considered Earthquake (MCE) 5% damped, spectral response acceleration parameter at a period of 1 second as defined in ASCE 7-05, Section 11.4.3	
Fa	Site Coefficient (ASCE 7-05, Table 11.4-1)	
Ss	Mapped MCE Spectral Response Acceleration at short periods as determined in accordance with ASCE	
RFUz	Total Uplift Force Resisted by RapidFeet	lbs
BWT	Total Ballast Weight	lbs
BW _{Tr}	Revised Total Ballast Weight	lbs
BW_m	Revised Total Ballast Weight per Module	lbs
AUF_e	Allowable Uplift Force for each ballast frame	lbs

Appendix B - Equations

1. $p_u = q_h \times G \times C_{nU}$
2. $p_D = q_h \times G \times C_{nD}$
3. $q_h = 0.00256 \times K_z \times K_{zt} \times K_d \times V^2 \times 1$
4. $q_h = 0.0019 \times K_z \times V^2$
5. $WLF_U = ma \times p_u$
6. $WLF_D = ma \times p_D$
7. $WLF_{Uz} = WLF_U \times \text{COS}(10^\circ)$
8. $WLF_{Uv} = WLF_U \times \text{SIN}(10^\circ)$
9. $WLF_{Dz} = WLF_D \times \text{COS}(10^\circ)$
10. $WLF_{Dv} = WLF_D \times \text{SIN}(10^\circ)$
11. $SL_r = SL_q \times \text{COS}(10^\circ)$
12. $SLF_r = SL_r \times ma$
13. $LC1 = DLF1 + SLF_r$
14. $LC2 = DLF1 + WLF_{Dz}$
15. $LC3 = DLF1 + (0.75 \times SLF_r) + (0.75 \times WLF_{Dz})$
16. $LC4 = (0.6 \times dLF1) + WLF_{Uz}$
17. $LC5 = DFL2 + (0.7 \times E)$
18. $BW_{Uv} = (0.6 \times dLF1 + BW_{Uz} + DLF_{Uz})$
19. $BW_{drag} = (DLF_{Uv} - BW_{uy}) / 0.4$
20. $BW_c = BW_{Uz} + BW_{drag}$
21. $.043 \times BW_c = BW_e$
22. $1.5 \times BW_e = BW_r$
23. $(BW_{uz} + BW_{drag}) / 26 = \text{ASCE 7-05 Code Calculated Number of Ballast blocks per module}$
24. $aa = (a_{EW} \times a_{NS}) / 144$
25. $dL2 = (dL1 + BW) / aa$
26. $V_{SBS} = C_s \times W_s$
27. $C_s = S_{DS} / (R / I_s)$
28. $S_{DS} = (2 / 3) \times S_{MS}$
29. $S_{MS} = F_a \times S_s$
30. $E = 0.443 \times DL2 = 0.443 \times DL2$
31. The number of RapidFoot attachments = $LC5 / ASF_{RF}$

Appendix C - Constants & Coefficients

K_z	Adjustment Factor for Building Height and Exposure Category	Table 6-3, p79 of ASCE 7-05, Case 2	
K_{zt}	Topographic Factor	1.00	
K_d	Wind Directionality Factor	0.85	
I	Importance Factor	0.87	
G	Gust Effect factor	0.85	
C_{nU}	Net Pressure Coefficient (Uplift)	-0.90	
C_{nD}	Net Pressure Coefficient (Downforce)	1.28	
	Tilt Angle, RRG10	10.00	°
	RR G10 Frame Weight	5.00	lbs
	RR G10 Frame with Brackets Weight	8.00	lbs
	Allowable Downforce in Z direction - rear bracket allowable compression force from testing	400.00	lbs
	Allowable Uplift Force in Z Direction - rear bracket allowable tensile force from allowable bolt shear published value	620.00	lbs
	Allowable Downforce Force in Y Direction - 2X bolt shear in upper connection	1034.00	lbs
	Allowable Uplift Force in Y Direction per Module Bracket - front bracket allowable tensile force from bolt tensile force published value	1034.00	lbs
	Safety Factor (Uplift Ballast Weight Requirement)	1.00	
	Weight of Ballast Blocks	26.00	lbs
	Coefficient of Friction (Rack Frame to Roof)	0.40	
	Correlation Factor from Wind Tunnel Test Results	0.43	
	Safety Factor (Wind Tunnel Test Results)	1.50	
	Allowable Withdrawal Force for RapidRac Connection in 22 ga Steel	1200.00	
	Seismic Load Force Coefficient, E	.665	
	Allowable Shear Force for RapidFoot Attachment	1200.00	lbs
R	Response Modification Factor in ASCE 7-05, Table 12.2-1	3.00	
F_a	Site Coefficient (ASCE 7-05, Table 11.4-1)	1.00	
S_s	Mapped MCE Spectral Response Acceleration at short periods as determined in accordance with ASCE 7-05, Section 11.4.1	2.00	
I_s	Importance Factor for Seismic determined in accordance with ASCE 7-05, Section 11.5.1	1.00	
C_s	Seismic Response Coefficient (ASCE 7-05, Section 12.8.1.1)	0.44	

10 year limited Product Warranty, 5 year limited Finish Warranty

Unirac, Inc., warrants to the original purchaser (“Purchaser”) of product(s) that it manufactures (“Product”) at the original installation site that the Product shall be free from defects in material and workmanship for a period of ten (10) years, except for the anodized finish, which finish shall be free from visible peeling, or cracking or chalking under normal atmospheric conditions for a period of five (5) years, from the earlier of 1) the date the installation of the Product is completed, or 2) 30 days after the purchase of the Product by the original Purchaser (“Finish Warranty”).

The Finish Warranty does not apply to any foreign residue deposited on the finish. All installations in corrosive atmospheric conditions are excluded. The Finish Warranty

is VOID if the practices specified by AAMA 609 & 610-02 – “Cleaning and Maintenance for Architecturally Finished Aluminum” (www.aamanet.org) are not followed by Purchaser. This Warranty does not cover damage to the Product that occurs during its shipment, storage, or installation.

This Warranty shall be VOID if installation of the Product is not performed in accordance with Unirac’s written installation instructions, or if the Product has been modified, repaired, or reworked in a manner not previously authorized by Unirac IN WRITING, or if the Product is installed in an environment for which it was not designed. Unirac shall not be liable for consequential, contingent or incidental damages arising out of the use of the

Product by Purchaser under any circumstances.

If within the specified Warranty periods the Product shall be reasonably proven to be defective, then Unirac shall repair or replace the defective Product, or any part thereof, in Unirac’s sole discretion. Such repair or replacement shall completely satisfy and discharge all of Unirac’s liability with respect to this limited Warranty. Under no circumstances shall Unirac be liable for special, indirect or consequential damages arising out of or related to use by Purchaser of the Product.

Manufacturers of related items, such as PV modules and flashings, may provide written warranties of their own. Unirac’s limited Warranty covers only its Product, and not any related items.



1411 Broadway Boulevard NE
Albuquerque NM 87102-1545 USA