

SolarEdge Quick Installation Guide – North America

For full installation and safety details, you must refer to the *SolarEdge Installation Guide*. Make sure you read, fully understand and follow the detailed instructions in the *SolarEdge Installation Guide* prior to each installation. **Failure to do so could result in injury or loss of life and damage or destruction of the equipment.**

The images contained in this document are for illustrative purposes only and may vary depending on product models.

Connecting Power Optimizers to Modules

1 Mount the power optimizers in a shaded location near the PV modules, on the structure or racking to which the module is attached, using the mounting holes. If possible, avoid mounting power optimizers in locations where they will be exposed to direct sunlight.

Make sure that each power optimizer is positioned within reach of each module’s cables. To allow proper heat dissipation, maintain a 1" / 2.5 cm clearance distance between the power optimizer and other surfaces.

2 Attach each power optimizer to the rack using the 5/16" or 1/4" bolts, nuts and washers.

3 Use the following methods to ground the power optimizer:

- **For mounting on a grounded metal rail:** Use the provided 5/16" stainless steel grounding star washer between the railing and the flat side of the mounting bracket. The grounding washer should break through the anodize coating of the railing to ensure low resistive connection. Apply torque of 9.5 N*m / 7 lb*ft.

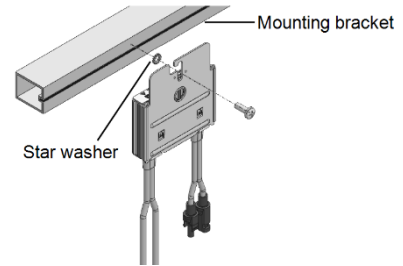

- **For mounting on rails with sliding nut fasteners, or an un-grounded structure** (such as a wooden structure): Connect an equipment-grounding conductor to the grounding terminal according to the instructions supplied with the grounding terminals (grounding terminal kits are available from SolarEdge). The grounding terminal accepts a wire size of 6-14 AWG, and must be sized for equipment grounding per NEC 250.122 requirements. Tighten the screws connecting the power optimizer to the frame and the grounding terminal screw. Apply torque of 9.5 N*m / 7 lb*ft.

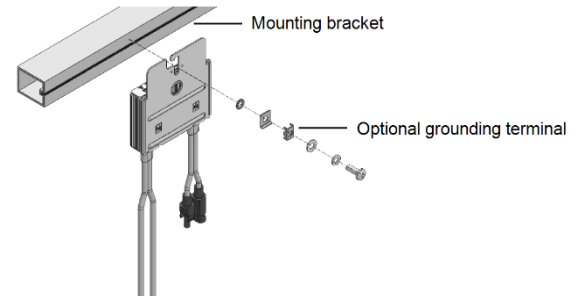

4 To benefit from the physical mapping of the installation in the SolarEdge Monitoring Portal, record each power optimizer’s serial number and location: Peel off its removable barcode sticker and stick it on the mapping template, or scan the barcode with the SolarEdge iPhone Site Mapper app. Upload the map to the SolarEdge website, using the site registration form.

5 Connect the Plus (+) output connector of the module to the Plus (+) input connector of the power optimizer.

6 Connect the Minus (-) output connector of the module to the Minus (-) input connector of the power optimizer.

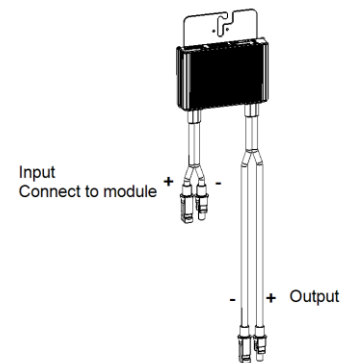

Connecting Power Optimizers in a String

1 Connect the power optimizer outputs in series: Connect the Minus (-) output connector of the string’s first power optimizer to the Plus (+) output connector of the string’s second power optimizer. Connect the rest of the optimizers in the string in the same way.

- The minimum and maximum string length should be according to the power optimizer datasheet.
- Strings **DO NOT** have to be of equal length.

2 Verify proper connection of power optimizers: Before the inverter is turned ON, each power optimizer produces 1V *safety-voltage*. Use a voltmeter to verify it for each string using a voltmeter. The voltage on a string is the number of modules multiplied by 1V, with a deviation of 10mV per module. Make sure the modules are exposed to sunlight during this process.

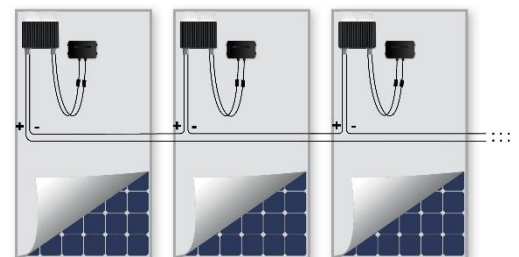

NOTE:

If several strings are connected in parallel, verify voltage for each string separately.

Installing the Inverter

- 1 Make sure that the inverter ON/OFF switch at the bottom of the inverter is switched OFF before and during the installation, and that the AC circuit breaker is OFF.
- 2 Use a 5mm Allen key to open the Safety Switch cover screws and remove the cover.

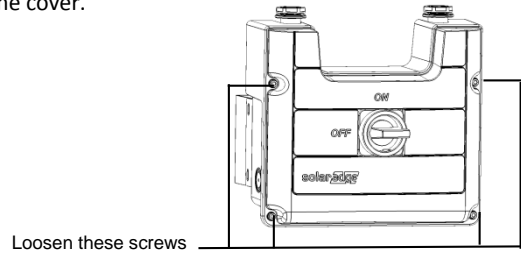

- 3 Open the required knockout pair (bottom, back or sides of the enclosure, sized 3/4" or 1") according to the conduits used in the installation.
- 4 Make sure to leave clearance areas in order to cool the inverter:
 - 8" above
 - At least 4" below (leaving sufficient clearance for conduits entering from the bottom)
 - 4" on either side
 - When installing inverters one above of the other - at least 16" between inverters.
 - When installing inverters side by side, follow these clearance specifications:

	Single Phase Inverters	Three Phase Inverters
Locations where the yearly average high temperature is below 25°C/77°F	8" between inverters	8" between inverters
Locations where the yearly average high temperature is above 25°C/77°F		16" between inverters

The inverter is supplied with one of the following two types of mounting brackets. The mounting steps in the next sections refer to these types.

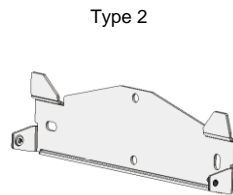
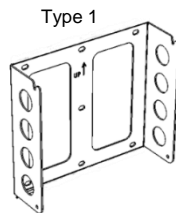

- For type 1:
 - Install the mounting bracket on the wall with the U-shaped indentations facing up, and the "UP" marking is correctly oriented.

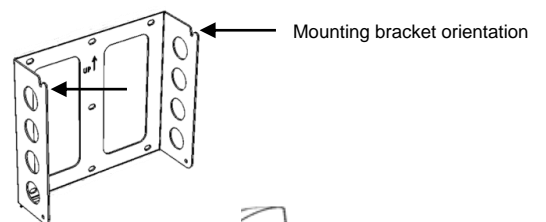

- Hang the inverter on the bracket.
- Secure the inverter to the bracket using the two supplied screws.

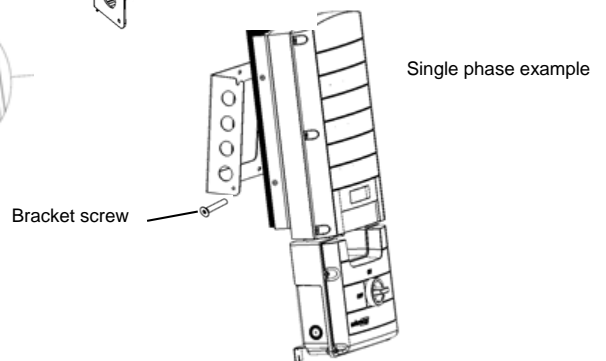

■ For type 2:

- Install the mounting bracket on the wall with the flat side of the bracket is at the bottom.
- Hang the inverter on the bracket: Align the two indentations in the inverter enclosure with the two triangular mounting tabs of the bracket, and lower the inverter until it rests on the bracket evenly.
- Secure the inverter to the bracket using the two supplied 5mm screws.

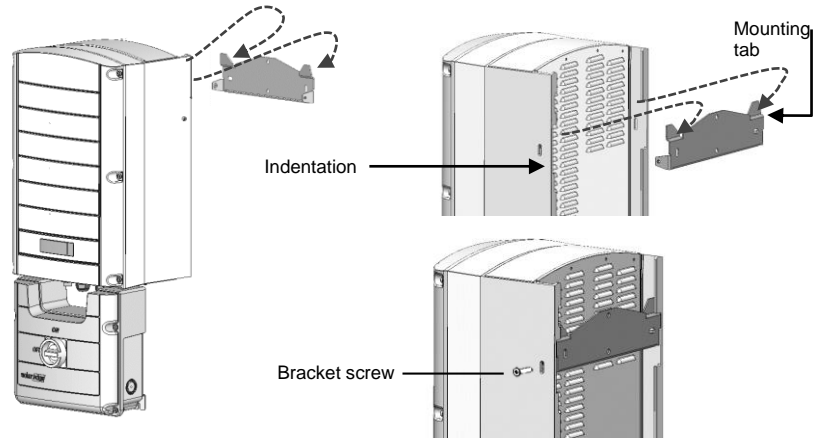

NOTE:

When mounting an inverter with Type 2 bracket on an uneven surface, you may use spacers/washers behind the top mounting hole of the bracket. Depending on the angle, use the appropriate size and number of spacers so that the bracket is perpendicular to the ground. Recommended: a stainless steel 3/4" long screw, with a 1/4" socket button head, two jam nuts and three washers.

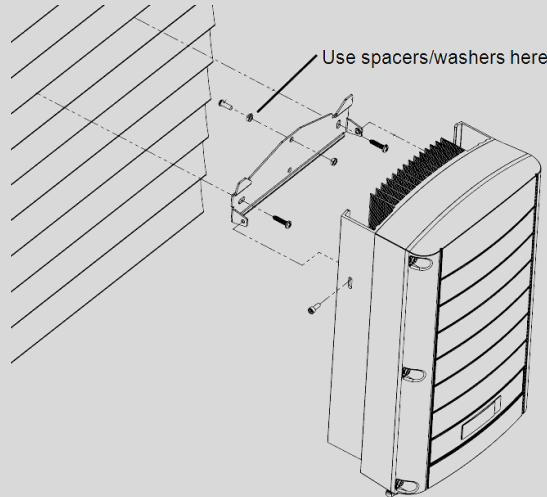

5 Optionally, secure the Safety Switch bracket to the wall:

- Mark the location of the bracket screw for the Safety Switch and drill the hole.
- Fasten the bracket using a standard bolt.

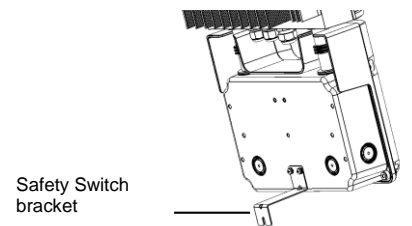

Connecting the Strings and the AC to the Safety Switch

An example of the Safety Switch connections is shown below. For more information, refer to the note in the device and to the *SolarEdge Installation Guide*.

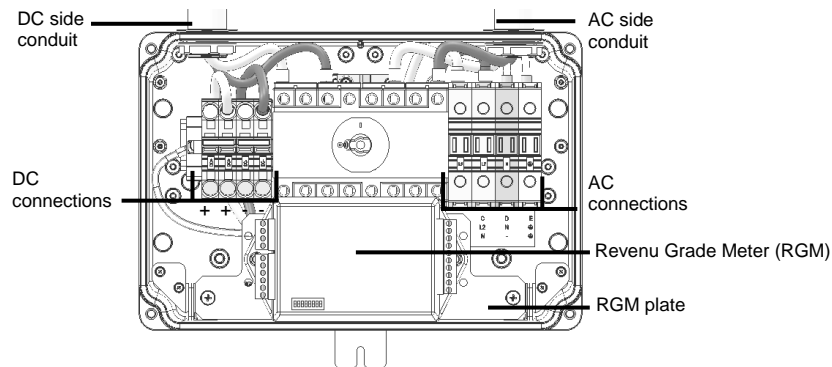

Safety Switch for single phase inverter 10-11.4kW with built-in RGM

Connecting the AC Grid

If the Safety Switch has a pre-assembled RGM (in single phase inverters), flip the RGM plate downwards before making the connections.



WARNING!

Connect the equipment grounding before connecting the AC wires to the AC terminal block.
Veillez à relier le conducteur de PE (la terre) avant de connecter les fils CA au bornier CA.

- 1 Insert the AC conduit into the AC-side knockout that was opened.
- 2 Connect the wires, and check that they are fully inserted and cannot be pulled out easily:

- *Single phase 3-7.6kW inverter* - Connect the wires to the appropriate terminal blocks, according to the labels on the terminal blocks. Connect the grounding wire first. Use a standard straight-bladed screwdriver to connect the wires to the spring-clamp terminals.

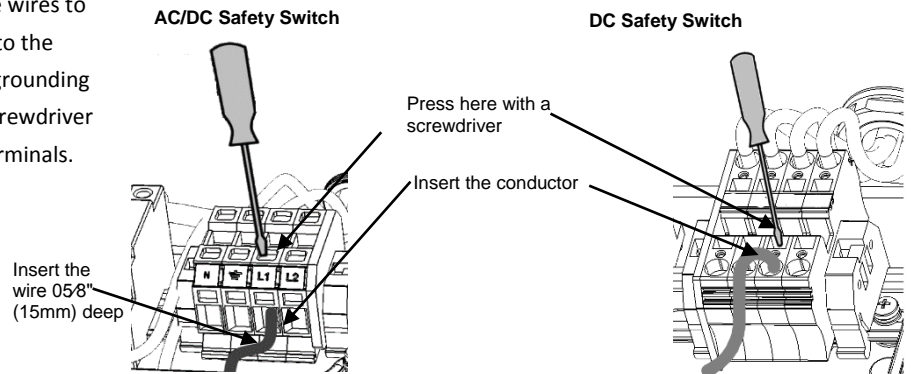

- *Single phase 10-11.4 kW inverter* - Connect the wires to the appropriate terminal blocks, according to the label on the terminal blocks. Connect the grounding wire first. Use a 03/16" (5mm) straight flat-blade screwdriver to connect the wires to the terminals.

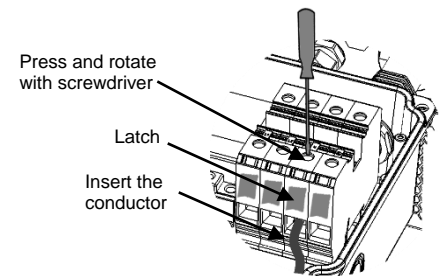

- *Three phase inverter*
 - For *AC/DC Safety Switch*: - Connect the Ground and Neutral wires to the terminal blocks in the AC side of the switch. Connect the line wires to the appropriate connectors according to the label located in the switch.
 - For *DC Safety Switch*: Use a standard flat-blade screwdriver to connect the wires to the spring-clamp terminals

- L1 L2 L3

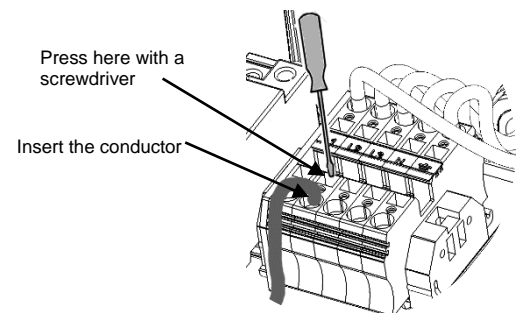

NOTE:

Three phase inverters require neutral connection at all times (only WYE type grids with neutral connection are supported).

- 3 Verify that there are no unconnected wires.

Connecting the Strings

- 1 Insert the DC conduit into the DC-side knockout that was opened.
- 2 Connect the DC equipment ground conductor to the equipment grounding terminal block.



NOTE:

Functional Electrical Earthing of DC-side negative or positive is prohibited because the inverter has no transformer. Earthing of module frames and mounting equipment (equipotential bonding) is required per NEC.

- 3 Connect the DC wires, and check that they are fully inserted and cannot be pulled out easily. If the Safety Switch has a pre-assembled RGM (in single phase inverters), flip the RGM plate before making the connections, and then return the plate:
 - *Single phase 3-7.6kW inverter* - Connect the DC wires from the PV installation to the DC+ and DC- terminal blocks, according to the labels on the terminals. Use a standard straight-bladed screwdriver to connect the wires to the spring-clamp terminals. Refer to the figures above.
 - *Single phase 10-11.4kW inverter* - Connect the DC wires from the PV installation to the DC+ and DC- terminal blocks, according to the labels on the terminals. Use standard flat-blade screwdriver to connect the wires to the spring-clamp terminals as shown in the figures above.
 - *Three phase inverter*
 - Safety switch version *without terminal blocks on the DC side* - Connect the DC wires from the PV installation to the DC+ and DC- terminals on the switch, according to the labels.
 - Safety switch version *with terminal blocks on the DC side* - Connect the DC wires from the PV installation to the DC+ and DC- terminal blocks.



CAUTION:

Ensure that the Plus (+) wire is connected to the Plus (+) terminal and that the Minus (-) wire is connected to the Minus (-) terminal.
Veillez à ce que le câble Plus (+) soit connecté au terminal Plus (+) et que le câble Minus (-) soit connecté au terminal Minus (-).

- 4 If more than two strings are required, they can be connected in parallel in an external combiner box before connecting to the switch.



NOTE:

If more than two strings are connected each should be properly fused on both DC+ and DC- according to NEC690.35(B).

- 5 If the Safety Switch has a pre-assembled RGM, flip the RGM plate upwards to its original position.
- 6 Close the switch cover.

Inverter Interfaces

The following figure shows the inverter connectors and components, located at the bottom of the inverter. The ON/OFF switch and the LCD light button may vary depending on the inverter model:

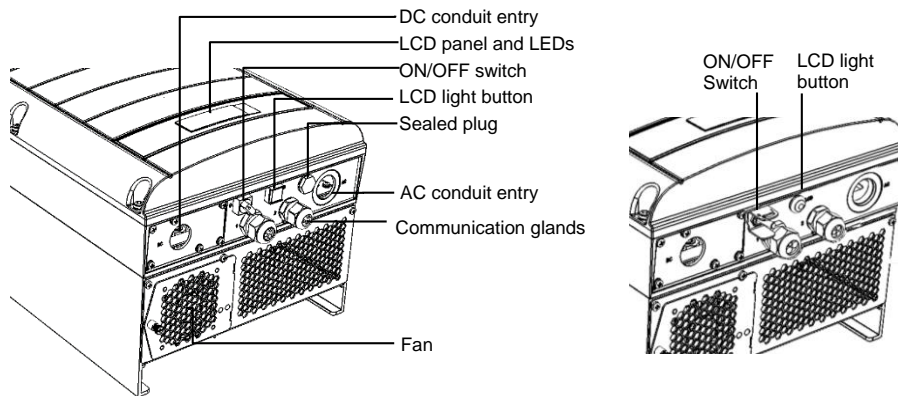

Commissioning and Activating the Installation

- 1 Verify that the inverter ON/OFF switch is OFF.
- 2 Turn ON the AC breaker.
- 3 Move the Safety Switch to the ON position.
- 4 Remove the inverter cover: Open the inverter cover's six Allen screws and carefully pull the cover vertically before lowering it.



WARNING!

ELECTRICAL SHOCK HAZARD. Do not touch uninsulated wires when the inverter cover is removed.
RISQUE D'ÉLECTROCUTION. Ne touchez pas les fils non isolés lorsque le couvercle de l'onduleur est retiré.

- 5 Activate the inverter according to the activation instructions supplied in the inverter package.
- 6 Verify that the inverter is configured to the proper country or grid setting: Press the LCD light button until reaching the ID status screen:

```

ID : ##### ##
DSP 1 / 2 : 1 . 0 2 1 0 / 1 . 0 0 3 4
CPU : 0 0 0 2 . 0 1 1 1
Country : U S A 2
    
```

- 7 If required, perform the following additional steps before closing the inverter cover:
 - Country settings or inverter configuration using the internal LCD user buttons, located just above the LCD and are numbered **esc, 1, 2, 3/Enter** from left to right. Enter the menus by pressing **ENTER** for five seconds and then inputting the password 12312312. To verify that the country code is set to USA, select **Country** from the main menu, press **Enter** and select **USA+**. In the next menu that appears, select the desired AC grid configuration.
 - Communication options connection – refer to *Setting up Communication* on page 7.
- 8 Close the inverter cover by tightening the screws with a torque of 9.0 N*m/ 6.6 lb*ft. For proper sealing, first tighten the corner screws and then the two central screws.
- 9 Make sure the Safety Switch is ON. If an additional external DC switch is installed between the power optimizers and the inverter(s) then turn it ON.

A message similar to the following appears on the inverter LCD panel:

```
V a c [ V ]   V d c [ V ]   P a c [ W ]
2 4 0 . 7     1 4 . 1     0 . 0
P _ O K :    0 0 0 / 0 0 0   < S _ O K >
                   O F F
```

- 10 Verify that the following information appears on the LCD panel:
 - **Vac[V]:** Specifies the grid voltage.
 - **Vdc[V]:** The DC input voltage of the longest string connected to the inverter. There should be a safety voltage of 1V for each power optimizer in the string.
 - **Pac[W]:** AC power production. At this stage, it should be 0w.
 - **P_OK:** Specifies the number of properly connected power optimizers.
 - **S_OK:** Indicates the status of the connection to the SolarEdge monitoring portal (if connected).



WARNING!

Before proceeding to the next step, make sure that the cover is closed! High DC Voltage will be present in the inverter following the next step!
Avant d'entamer la prochaine étape, assurez vous que le couvercle est fermé ! Une tension DC très haute sera présente durant l'étape suivante !

Pairing Power Optimizers to the Inverter

- 1 Verify that the ON/OFF switch at the bottom of the inverter is OFF.
- 2 Press and hold down the inverter LCD button for about 10 seconds. The following message is displayed:

```
Keep holding button
for pairing, release
to enter menu...
Remaining: 3 sec
```

Keep holding for 5 seconds until the following is displayed:

```
Pairing
Turn Switch To On
```

- 3 Turn the inverter ON within 5 seconds. If you wait longer than 5 seconds, the inverter exits the pairing mode. The following message is displayed indicating that the inverter is performing the pairing.

```
Pairing
Remaining [sec]: 180
```

- 4 Wait for the completion of the pairing (remaining seconds is 0). If pairing fails, an error is displayed. In this case, repeat the pairing steps.
- 5 When pairing succeeds, the following message is displayed:

```
Pairing
Pairing Completed
```

- 6 At the end of the pairing process, the system will start producing power. Verify on the LCD screen that the number next to P_OK equals the number of installed power optimizers. It may take up to 20 minutes until all the power optimizers are indicated.



WARNING!

After you turn ON the inverter ON/OFF switch, the DC cables carry a high voltage and the power optimizers no longer output a safe 1V output.

Après avoir mis l'interrupteur ON/OFF de l'onduleur monophasé sur ON, les câbles DC portent une haute tension et les optimiseurs de puissance ne génèrent plus la tension de sécurité de 1V.



WARNING!

After you turn OFF the inverter ON/OFF switch, wait until the LCD indicates that the DC voltage is safe (<50V), or wait five minutes before opening the cover or disconnecting the strings.

Après avoir tourné l'interrupteur ON/OFF sur OFF, attendre jusqu'à ce que l'écran LCD indique que la tension DC est sécurisée (<50V) ou attendre cinq minutes avant d'ouvrir le couvercle ou de déconnecter les strings.

Setting up Communication

Two communication glands are used for connection of the various inverter communication options. Each gland has three openings. The table below describes the functionality of each opening. Unused openings should remain sealed.

Gland#	Opening	Functionality	Cable Size (diameter)
1 (PG 16)	One small	External antenna cable	2-4 mm
	Two large	Ethernet connection (CAT5/6), ZigBee, CDMA	4.5-7 mm
2 (PG 13.5)	All three	RS485, power reduction	2.5-5 mm

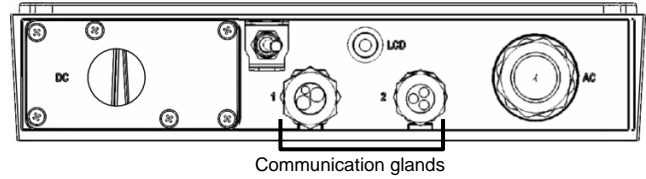

Cable Specifications

- Ethernet:
 - Cable type – CAT5/CAT6
 - Maximum distance between the inverter and the router – 100 m/ 330 ft.
- RS485:
 - Cable type: Min. 3-wire shielded twisted pair (a 4-wire cable may be used)
 - Wire cross-section area: 0.2- 1 mm²/ 24-18 AWG (a CAT5 cable may be used)
 - Maximum nodes: 32
 - Maximum distance between first and last devices: 1 km /3300 ft.



NOTE:

If using a cable longer than 10 m/33 ft in areas where there is a risk of induced voltage surges by lightning, it is recommend to use external surge protection devices. For details refer to: http://www.solaredge.us/files/pdfs/lightning_surge_protection.pdf. If grounded metal conduit are used for routing the communication wires, there is no need for a lightning protection device.

Creating an Ethernet (LAN) connection

- 1 Make sure that the ON/OFF switch at the bottom of the inverter is turned OFF, and the Safety Switch is turned OFF.
- 2 Remove the plastic seal from the large opening that has a cut in communication gland #1 and insert an Ethernet CAT5/6 cable through the opening.

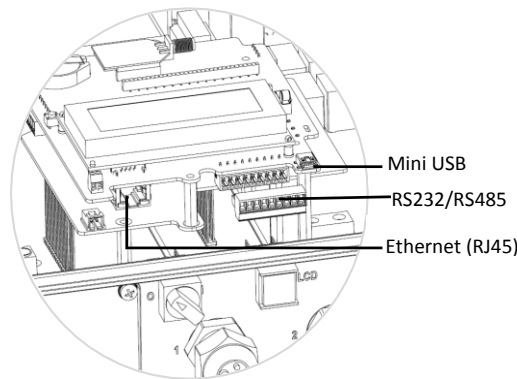

RJ45 Pin #	Color	
	T568B Standard	T568A Standard
1	White/Orange	White/Green
2	Orange	Green
3	White/Green	White/Orange
4	Blue	Blue
5	White/Blue	White/Blue
6	Green	Orange
7	White/Brown	White/Brown
8	Brown	Brown

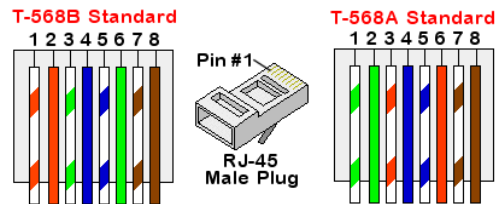

- 3 Use a pre-terminated cable to connect via gland no.1 to the RJ45 plug on the inverter's communication board, or, if using a spool of cable, connect as follows:
 - Insert the cable through gland no.1.
 - Insert the eight wires into an RJ45 connector, as described in the figure above.
 - Use a crimping tool to crimp the connector.

- Connect the Ethernet connector to the RJ45 port on the inverter's communication board.
- 4** For the switch/router side, use a pre-crimped cable or use a crimper to prepare an RJ45 communication connector: Insert the eight wires into the RJ45 connector, maintaining the same color coding and pinout on both sides of the Ethernet cable.
- 5** Connect the cable's RJ45 connector to the RJ45 port of the Ethernet switch or router.
- 6** Inverters are configured by default to LAN. If reconfiguration is required:
 - Make sure the ON/OFF switch is OFF.
 - Turn ON the AC to the inverter by turning ON the circuit breaker on the main distribution panel.



WARNING!

ELECTRICAL SHOCK HAZARD. Do not touch uninsulated wires when the inverter cover is removed.
RISQUE D'ÉLECTROCUTION. Ne touchez pas les fils non isolés lorsque le couvercle de l'onduleur est retiré.

- Use the user buttons to configure the connection.

Creating an RS485 connection

If a revenue grade meter is connected to your inverter, it uses the RS485 port and therefore an RS485 communication bus cannot be created.

- 1** Make sure that the ON/OFF switch at the bottom of the inverter is turned OFF, and the Safety Switch is turned OFF.
- 2** Remove the seal from one of the openings in communication gland #2 and insert the wire through the opening.
- 3** Pull out the 9-pin RS485/RS232 terminal block connector, and loosen the screws of pins **B**, **A** and **G** on the left of the RS-485 terminal block.
- 4** Insert the ends of wires into the **G**, **A** and **B** pins. Use four- or six-wire twisted pair cable for this connection. You can use any color wire for each of the **A**, **B** and **G** connections, as long as the same color wire is used for all A pins, the same color for all B pins and the same color for all G pins.
- 5** For creating an RS485 bus - connect all B, A and G pins in all inverters.
- 6** Tighten the terminal block screws, and push it firmly all the way into the communication board.
- 7** Terminate the first and last inverters in the chain by switching a termination Dip-switch inside the inverter to ON (move the left switch to the top). The switch is located on the communication board and is marked **SW7**.
- 8** To connect to the SolarEdge monitoring portal, designate a single inverter as the connection point between the RS485 bus and the monitoring portal. This inverter will serve as the master inverter. Connect the master to the SolarEdge monitoring portal via one of the communication options.

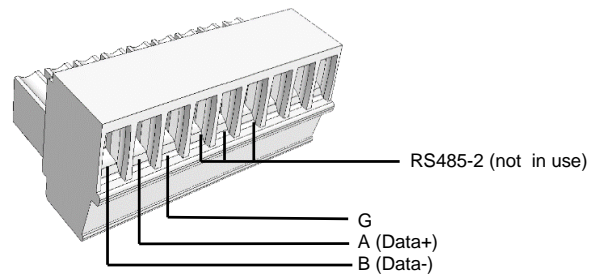

Using the optional ZigBee communication option

Refer to the ZigBee kit user manual.

Refer to the *SolarEdge Installation Guide* for detailed installation and safety instructions.

Support and Contact Information

If you have technical problems concerning our products, please contact us:

- USA and Canada:** +1 (0) 877 360 5292
- Worldwide:** +972 (0) 73 240-3118
- Fax:** +1 (0) 530 273-2769

Email to support@solaredge.us