

Junction Box XL for Rail Installation Manual

Part No. 242-92120

Materials Included

- ① (1) SnapNrack Junction Box XL Body
- ② (1) SnapNrack Junction Box XL Lid w/ Gasket
- ③ (2) SnapNrack Junction Box XL Rail Mount Brackets
- ④ (1) 5/16"-18 X 1-1/4" SS HCS Bolt
- ⑤ (1) SnapNrack Channel Nut
- ⑥ (2) 5/16"-18 X 1" SS HCS Bolt
- ⑦ (2) 5/16"-18 Self-Retaining Washer

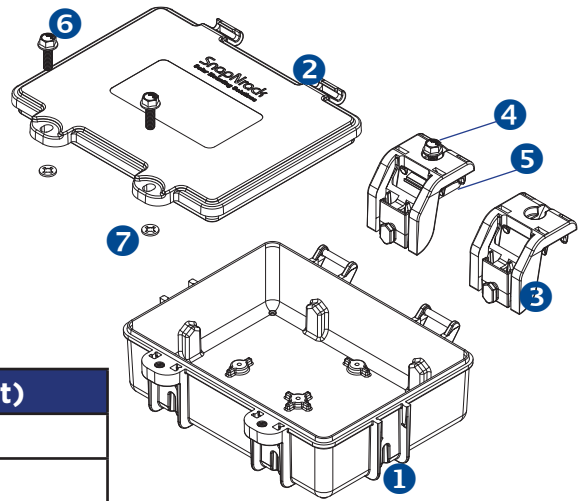

Hardware Description	Torque Specification (lb-ft)
Junction Box XL Channel Nut	5 lb-ft (60 lb-in)
Junction Box XL Lid	3 lb-ft (36 lb-in)

Technical Specifications	
Internal Dimensions	8.8" x 6.3" x 2.5" (inner box area)
Material	Box: Polycarbonate Gasket: Closed Cell Foam
UL Environmental Rating	Type 4X
Certifications	UL50/UL50E
Compatibility	Box Mount: Ultra Rail, S100 Standard Rail, S200 Ground Rail

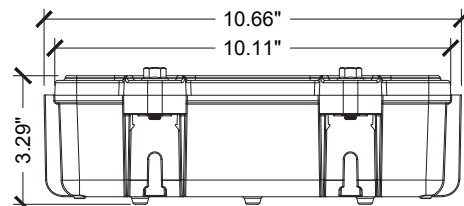
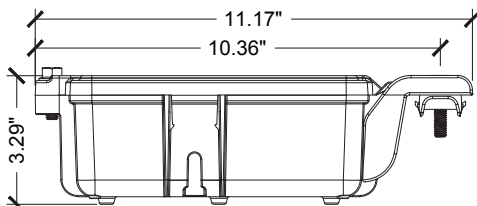
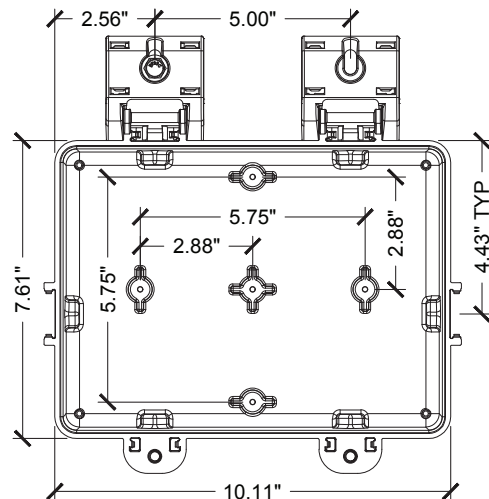
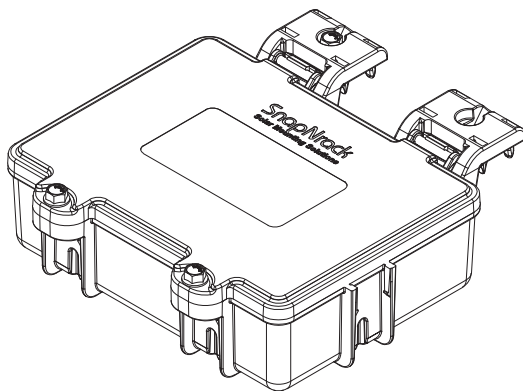

Required Tools

- Socket Wrench
- Torque Wrench
- 1/2" Socket

Step-by-Step Instructions

1. Attach Rail Brackets to the rear of the box. Slide each tab into the slot until it snaps into place.
2. Mount the junction box at the edge of the array where the conduit will terminate. Junction box access after installation should not require the removal of more than one module.
3. Tilt bolts and channel nuts so one side of channel nut can easily fall into top rail channel. Press junction box until both clips snap into top rail channel.
4. Pull up on the head of the bolts to snap the channel nuts into the top rail channel. Torque mount bolts to 5 lb-ft (60 lb-in).

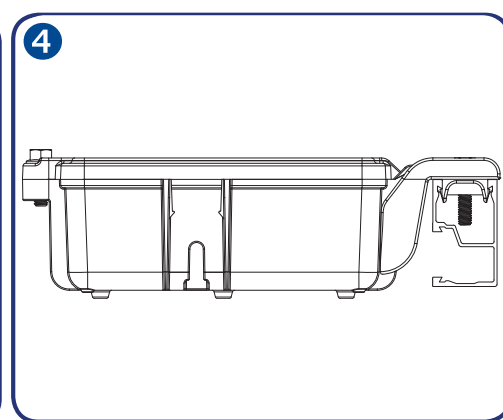
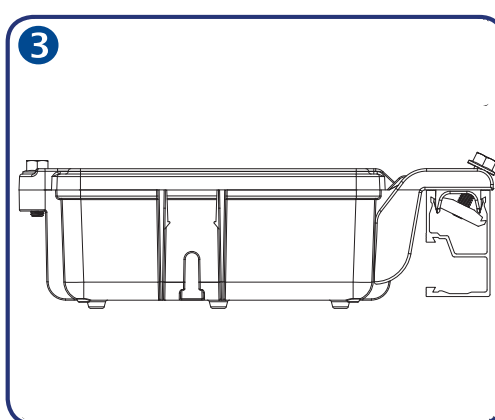
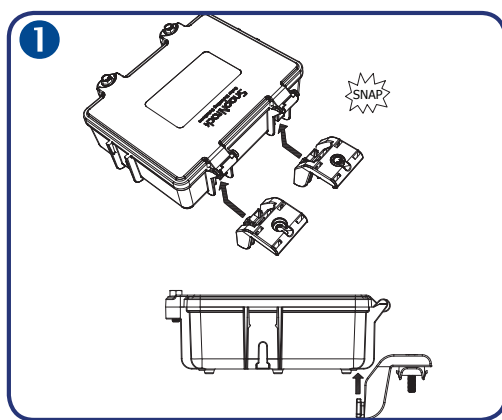

5. Install outdoor-rated, sealed conduit fittings or sealed strain reliefs to side wall of junction box and complete wiring installation.

CAUTION: Nonmetallic enclosure does not provide grounding between conduit connections. Use grounding bushings and jumper wires.

6. Once wiring is complete, close lid and tighten bolts until the front lid tab makes contact with the tab on the box, then torque to 3 lb-ft (36 lb-in) minimum.

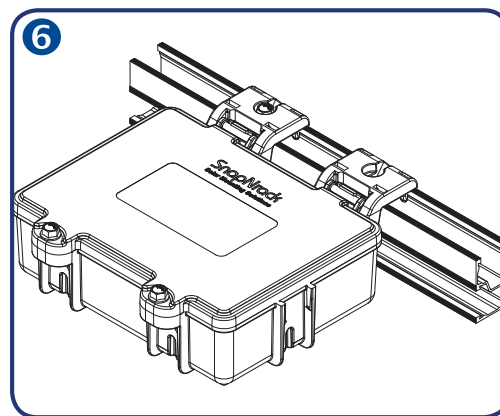
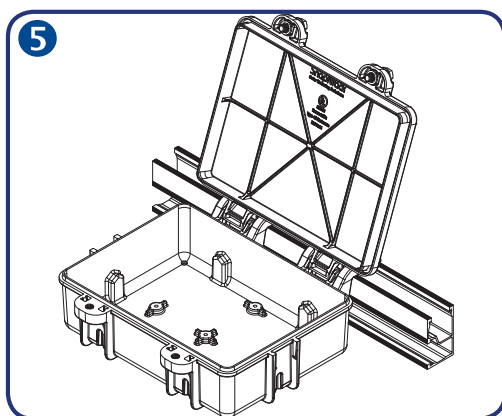

Installation Note:

To avoid the accumulation of water as a result of condensation inside junction boxes it is acceptable to add drainage openings with a minimum diameter of 1/8 inch and a maximum diameter of 1/4 inch. (Per NEC, 314.15)