

STANDARD CONCRETE PIER CONFIGURATION

SEE ENGINEERING TABLES FOR PIER DEPTHS AND SPAN LIMITATIONS.

UNLESS OTHERWISE SPECIFIED IN ENGINEERING DOCS, THE FOLLOWING VALUES APPLY:
 MAX RAIL LENGTH: 162"
 RAIL SPAN: 96"
 MAX RAIL OVERHANG: 32"

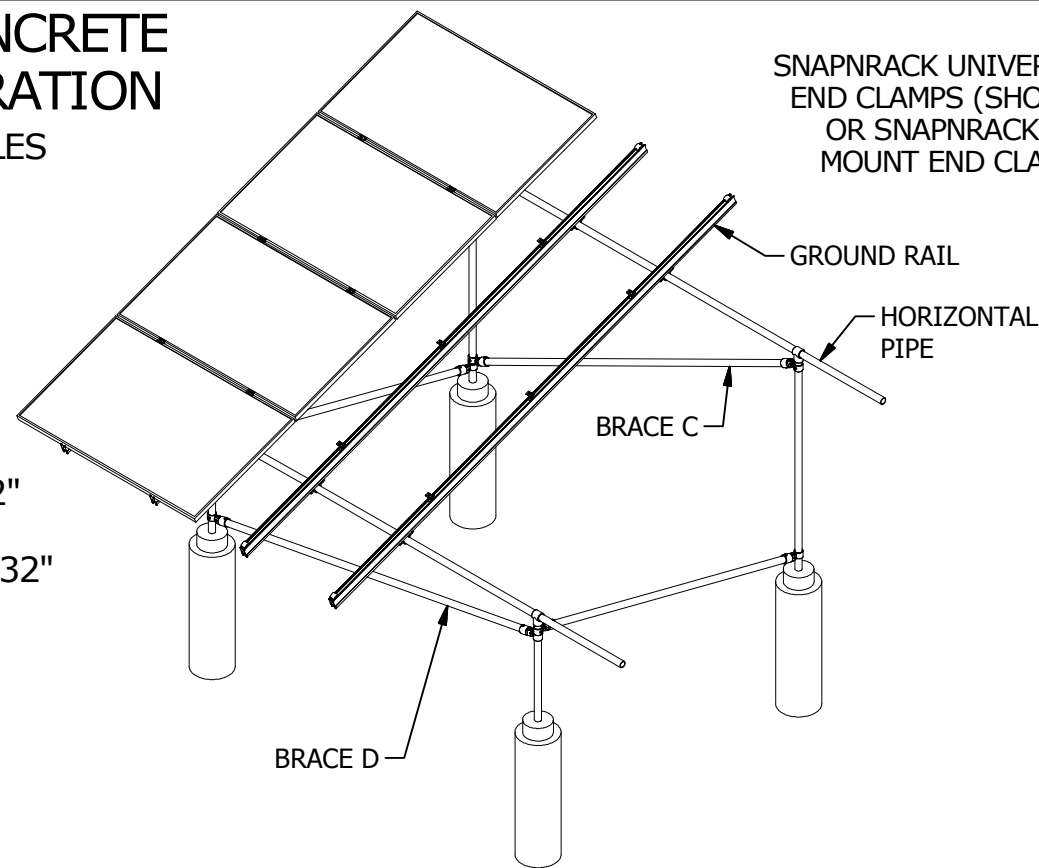

ISO VIEW OF RACKING ASSEMBLY

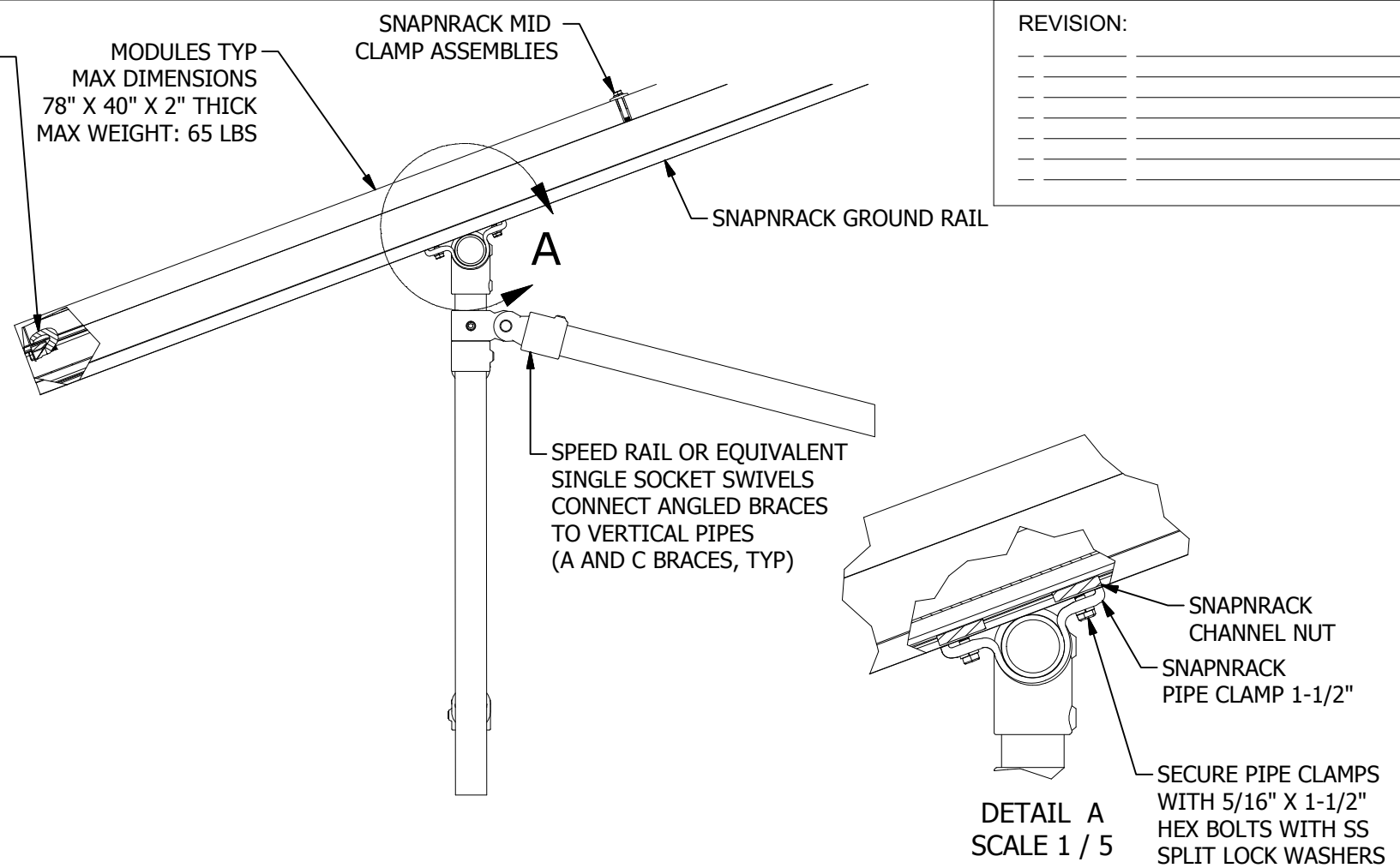

DETAILED VIEW OF PIPE TO RAIL AND BRACING INTERFACE

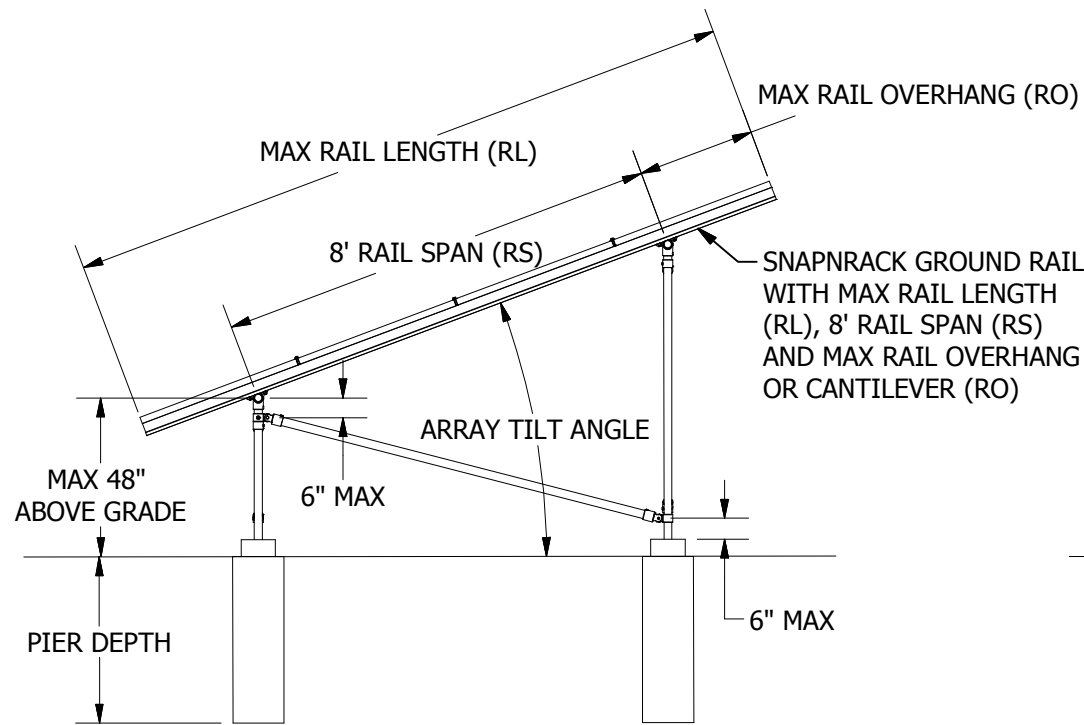

ARRAY SIDE VIEW

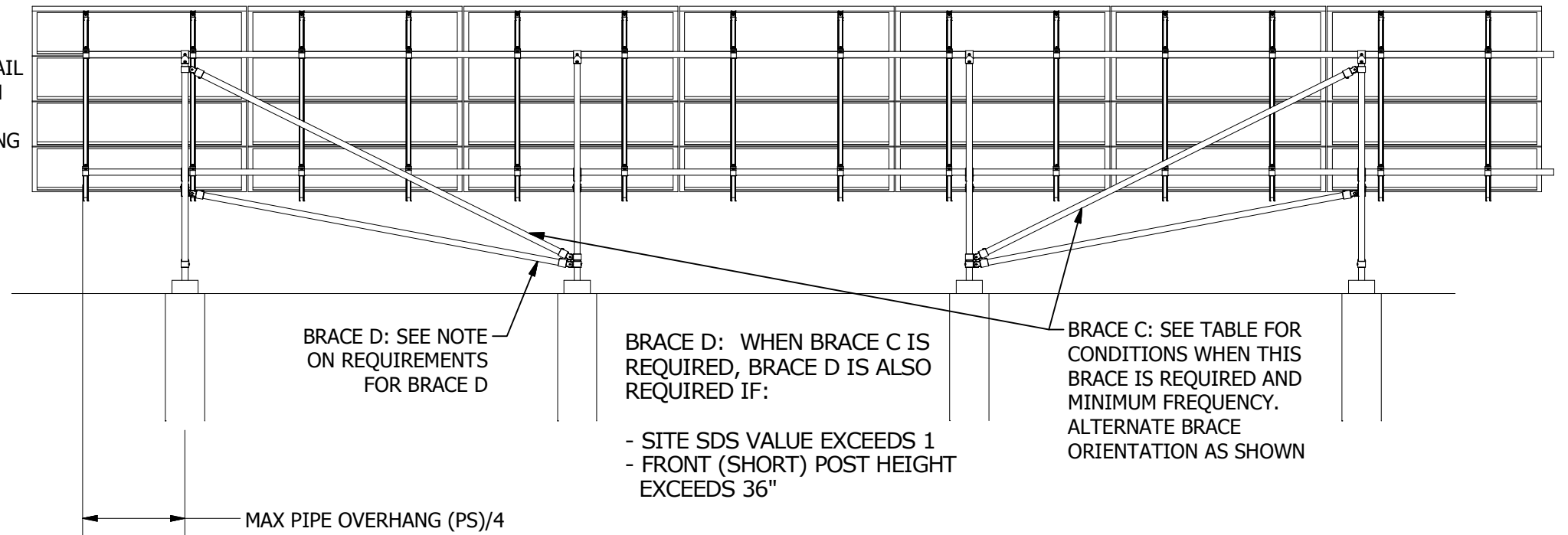

ARRAY BACK VIEW

REVISION:
