

ITEM NO.	DESCRIPTION	QTY.
1	QBASE, 1-1/4" ID, FOR 5/16" HARDWARE, A360.1 CAST AL	1
2	CAP SCREW, HEX HEAD, 5/16"-18 X 3/4" UNC-2A, GRADE 8	1
3	POST, 1.25" OD X 6.5", 6063-T5, MILL	1
4	LAG SCREW, HEX HEAD, 5/16" X 3", ZINC	2
5	SUBFLASHING, SPUN CONE, QBASE, 9"X9"X.020", 3003 AL, MILL	1
6	FLASHING, SPUN CONE, 18"X18"X.032", 3003 AL, MILL	1
7	COLLAR, COUNTER FLASHING, 1-1/4" ID EPDM	1
8	WASHER, SEALING, 5/16" ID X 1-1/4" OD, EPDM BONDED SS	1
9	WASHER, FENDER, 5/16" ID X 1" OD, 18-8 SS	1
10	WASHER, SPLIT-LOCK, 5/16" ID, 18-8 SS	1
11	CAP SCREW, HEX HEAD, 5/16"-18 X 1", UNC-2A - 18-8 SS	1

POST AND TOP FLASHING AVAILABLE IN MILL, CLEAR ANODIZED, AND DARK BRONZE ANODIZED FINISHES

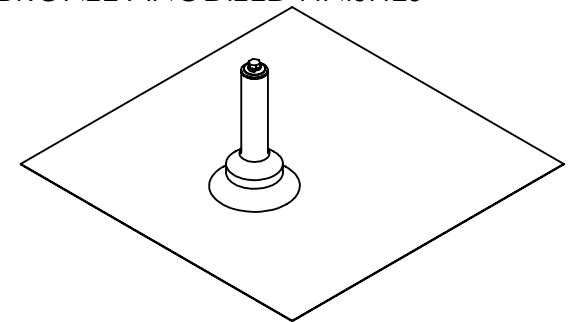

Quick Mount PV[®]

TITLE:
QMUTM: QBASE UNIVERSAL TILE MOUNT

UNLESS OTHERWISE SPECIFIED: DIMENSIONS ARE IN INCHES TOLERANCES: FRACTIONAL ± 1/16 TWO PLACE DECIMAL ±.02 THREE PLACE DECIMAL ±.005	SIZE A	DRAWN BY: MPW	REV 5
	SCALE: 1:8	DATE: 7/19/2012	WEIGHT: 2.24
		SHEET 1 OF 2	

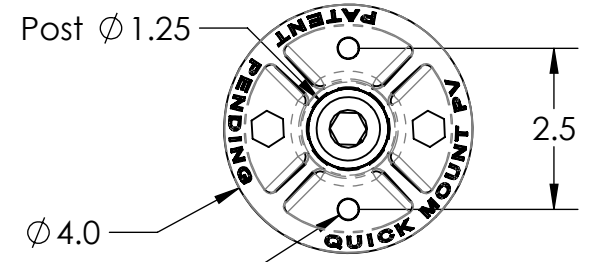
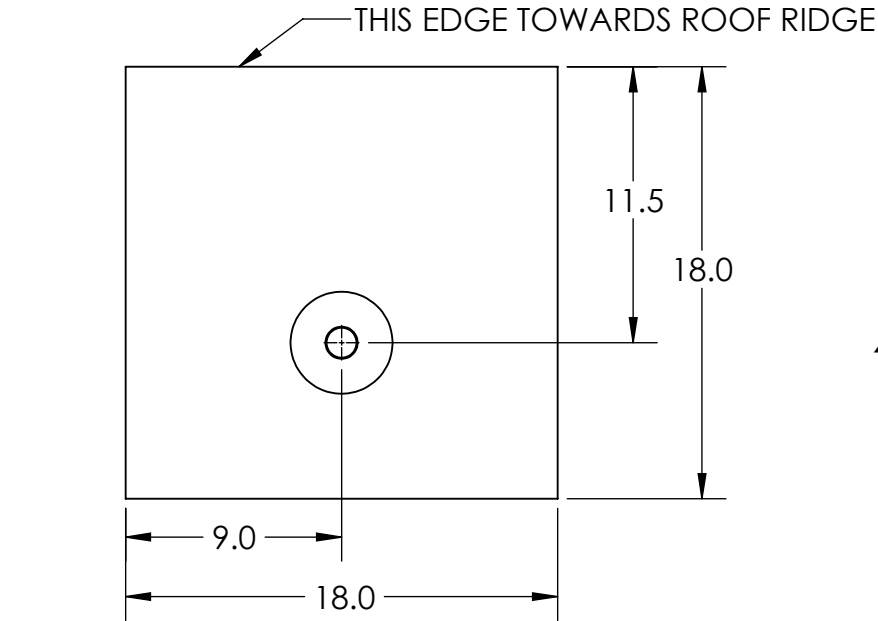

4X ϕ .32 TRHU (CLEARANCE FOR 5/16" HARDWARE)

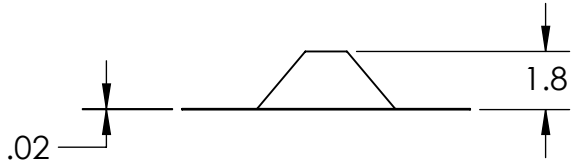
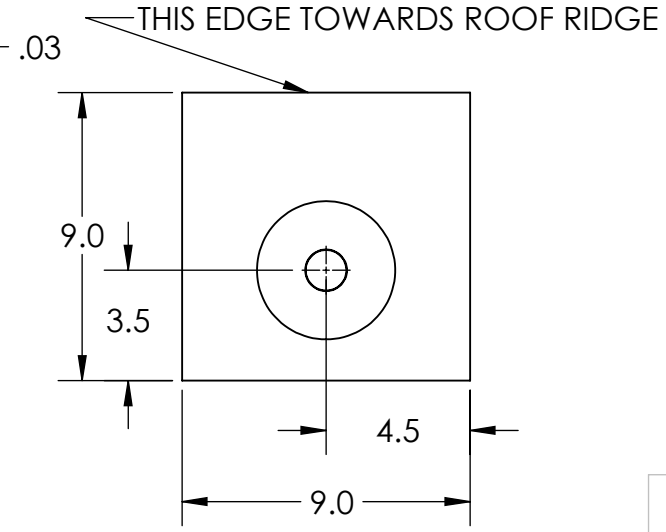
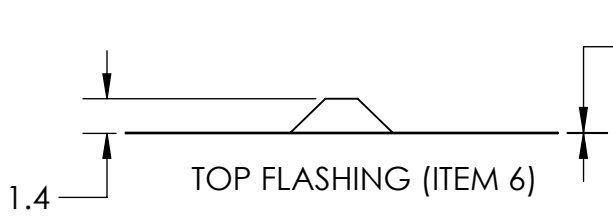

QBASE PRIMARY FLASHING (ITEM 5)

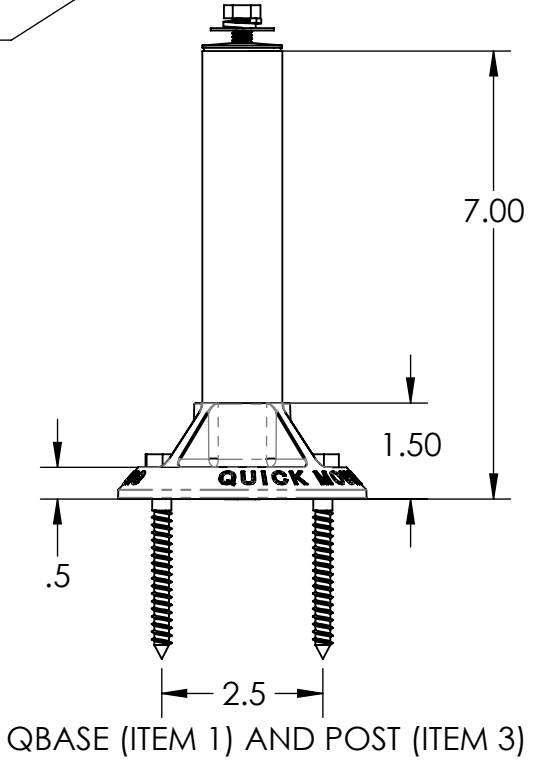

Quick Mount PV[®]

TITLE:
QMUTM: QBASE UNIVERSAL TILE MOUNT

UNLESS OTHERWISE SPECIFIED: DIMENSIONS ARE IN INCHES TOLERANCES: FRACTIONAL \pm 1/16 TWO PLACE DECIMAL \pm .02 THREE PLACE DECIMAL \pm .005	SIZE	DRAWN BY: MPW	REV
	A	DATE: 7/19/2012	5
	SCALE: 1:8	WEIGHT: 2.24	SHEET 2 OF 2

PROPRIETARY AND CONFIDENTIAL
THE INFORMATION CONTAINED IN THIS DRAWING IS THE SOLE PROPERTY OF QUICK MOUNT PV. ANY REPRODUCTION IN PART OR AS A WHOLE WITHOUT THE WRITTEN PERMISSION OF QUICK MOUNT PV IS PROHIBITED.

DO NOT SCALE DRAWING