

### APPLICATION:

The TileTrac® attachment can be used on both composition (comp) and concrete tile roof surfaces. The TileTrac® TT-18S is intended for use on comp roofs and the TileTrac® TT-18T is intended for use on tile roofs.

Note: The TileTrac® is not recommended for clay tile roofs.



### WARNING

All Professional Solar Products (ProSolar) are engineered and tested to withstand stated specifications (as stated on published specification sheets) when installed properly. Failure to install properly may decrease the performance of the installation.



### SAFETY

All regional safety requirements should be followed when installing ProSolar Products. All tools and equipment located on the roof should be secured to avoid falling object hazards. All equipment/tools should be properly maintained and inspected prior to use. Any exposed studs should be protectively capped to help avoid injury. This installation manual is intended for use by professional installers with a working knowledge of construction principles.

### Symbol Legend

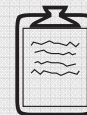

Explanation or Install Tip



Important Product Performance Information



Critical for Safety

### Tool List

- Chalk line
- Cordless rotary hammer drill with 3/8" carbide masonry bit (for concrete roof tile drilling).
- Cordless standard drill with 3/16" long drill bit (for lag bolt pilot hole)
- Cordless standard drill with 1/4" carbide masonry bit (for breaking through composition roof shingle surface only; NOT FOR PILOT HOLE)
- Cordless impact wrench with 1/2" socket
- Mastic or roof sealant recommended: Tripolymer based, such as Geocel 2300
- Lumber Crayon
- 3/16" T-handle hex key (for composition shingle roof)
- Precision electronic stud sensor
- Dead-blow hammer (approx. 20 oz)



Use of a Rotary Hammer drill is highly recommended. A Rotary Hammer drill (est. retail: \$500-\$700) reduces concrete roof tile drill time to approx. 2 seconds. A hammer drill (est. retail: \$250) will dramatically increase drill time to over one minute. Use of a standard drill will increase time to approx. 10 minutes.

### Installation steps overview

- 1) System layout & chalk line marking
- 2) Locating roof rafters along chalk lines
- 3a) Sealing/attaching TileTrac<sup>®</sup> (S-Tile Roof)
- 3b) Sealing/attaching TileTrac<sup>®</sup> (Composition Shingle Roof)
- 4) Clean up/Quality Inspection

## Step 1: System layout & chalk line marking

Prior to beginning attachment work, the system roof layout should be defined.

A drawing or sketch, prior to roof work, is recommended.

Upon finalizing layout, use chalk lines to mark support rail locations. The chalk lines will be used to align TileTrac<sup>®</sup> attachment points.

*Note: All support rails should be placed 48" apart along the module length. The rail distance from the end of the module will vary based on module size.*

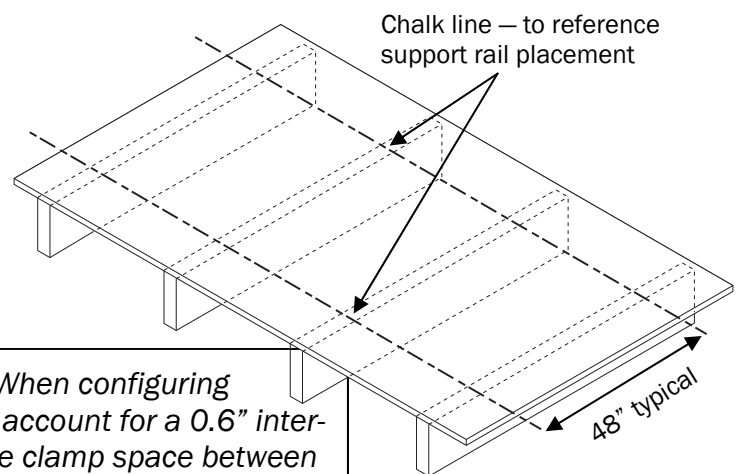

*Note: When configuring layout account for a 0.6" inter-module clamp space between modules and 2" for each end of the module array for end clamp spacing.*



The 48" grid design is based on 12", 16" or 24" on center (o/c) rafter spacing.  
(12" x 4 = 48", 16" x 3 = 48", 24" x 2 = 48")

All product specifications are based on 48" paired support rail spacing.

### Proper module/rail orientation—single array sample

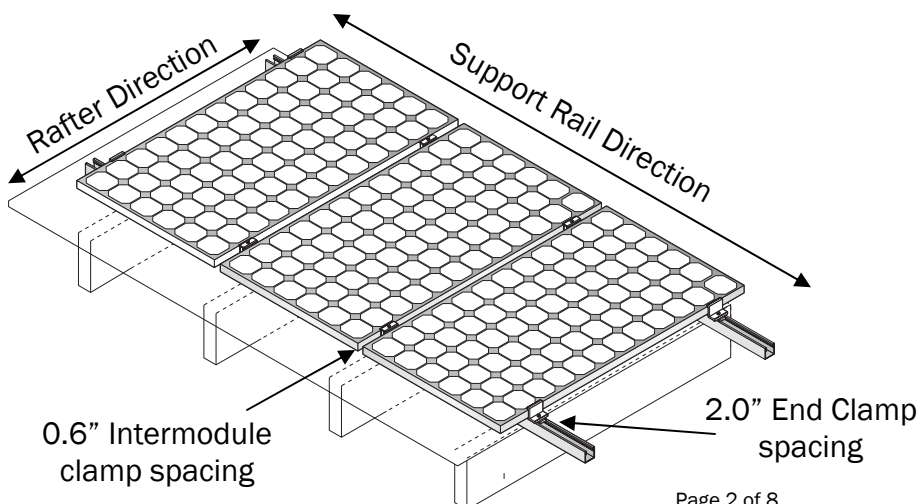

Clamps must secure the module on the **long end** of the frame. The span of the two support rails should be 48".

**EXAMPLE:** (Using a 64" long module)

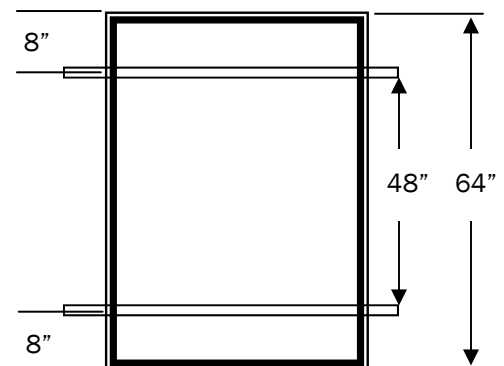

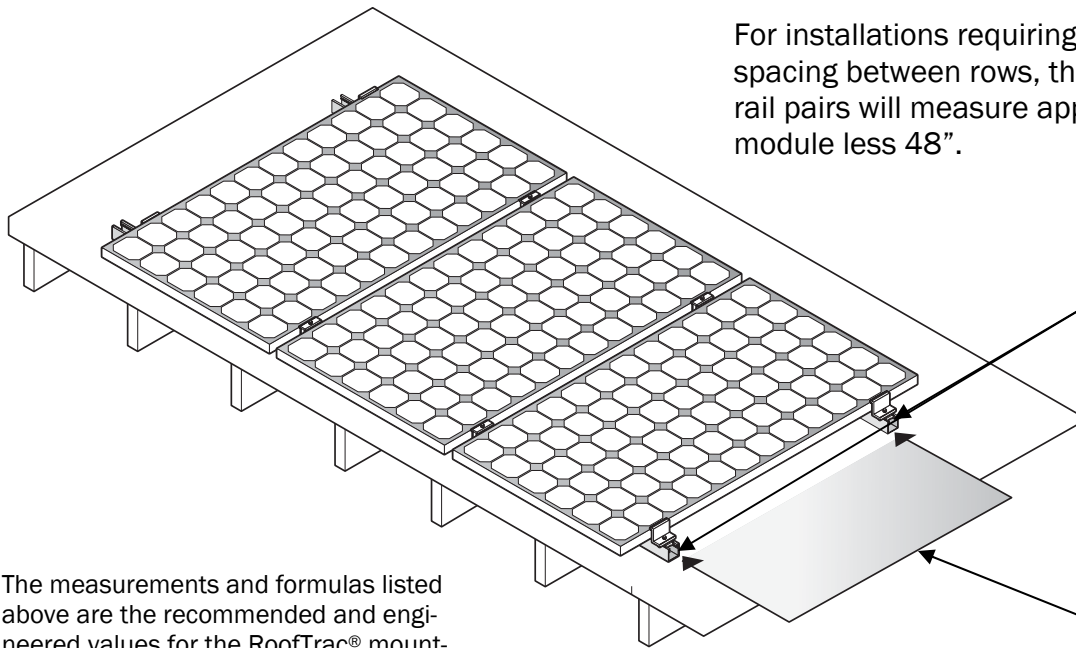

For installations requiring more than one row, with no spacing between rows, the distance between adjacent rail pairs will measure approximately the length of the module less 48”.

*Snap chalk lines along the location of where the support rails will be placed once spacing is calculated and measured.*

The measurements and formulas listed above are the recommended and engineered values for the RoofTrac<sup>®</sup> mounting system—non-tilt up.

**48”**

Actual spacing will be determined on pattern of the roofing material to ensure a proper seal.

## Step 2: Locating roof rafters along chalk lines

1) Since rafters are normally located every 48” on center (o/c), finding one reference rafter should be sufficient for approximating the location of additional rafters by measuring 48” from the center of the first.

2) If the roof eve (bottom edge of roof) is exposed, reference the bottom edge of the roof rafter location and use to approximate the location of the roof rafter/intersection chalk line on the upper section of roof. (EASIEST FOR TILE ROOF)

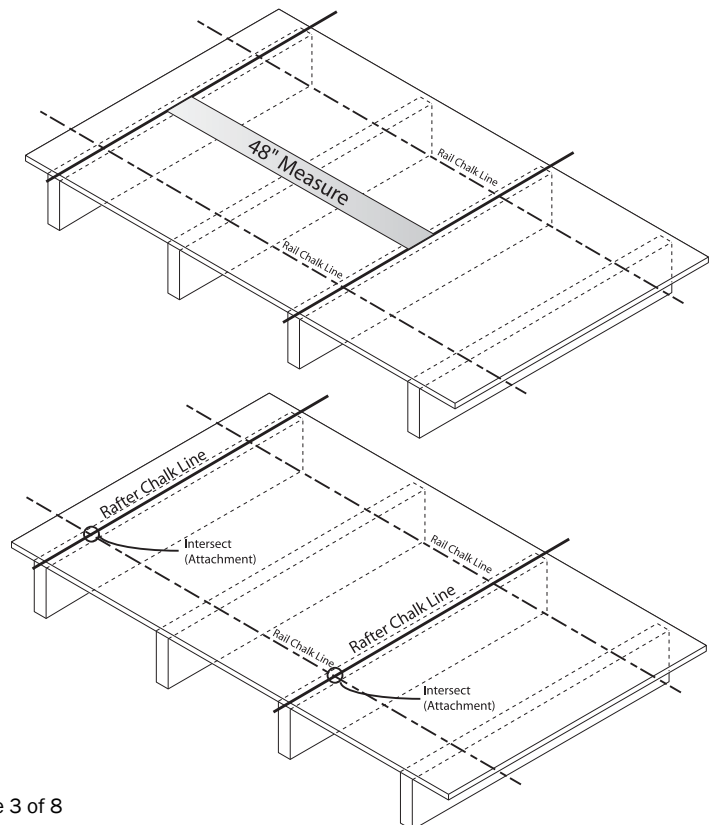

If the roof has a closed or blind soffit (enclosed rafters not visible at roof edge), the nailing pattern along the fascia board (board attached to ends of rafters) may indicate the rafter location at the bottom edge of the roof.

## Step 3a: Attaching / Sealing TileTrac® (Concrete Curve Tile Roof)



Mark (with lumber crayon) or account for ALL holes, including small nail holes to ensure roof is properly sealed. Approximate attaching/sealing time: 5 min. per attachment.

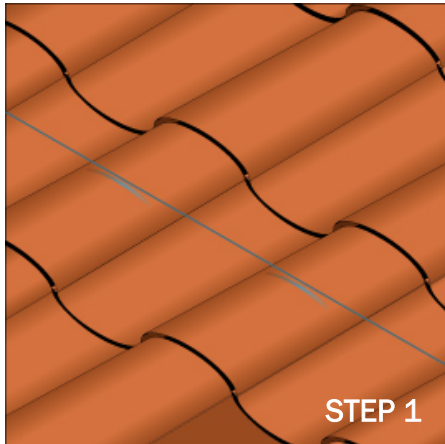

STEP 1

**STEP 1:** Select a tile in the area of the roof rafter referenced by your chalk lines.



STEP 2

**STEP 2:** Remove the tile by pushing and pulling the tile, usually held in place by a small nail.

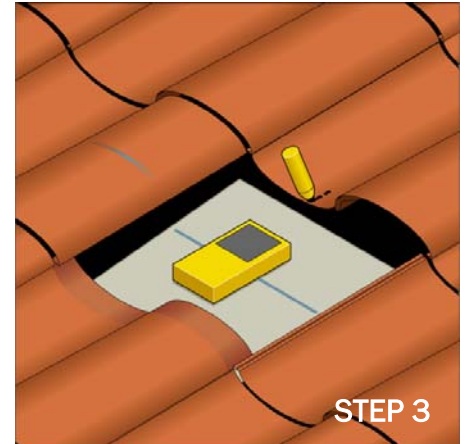

STEP 3

**STEP 3:** Using an electronic stud finder locate the rafter center. Mark a reference point on the tile above.



### Alternate methods of finding rafter center (STEP 3):

- 1) Using a dead-blow hammer, lightly tap perpendicular to the rafter until a solid sound is heard. Mark this location.
- 2) If attic is accessible, driving a nail upward beside the rafter may provide an adequate reference point.

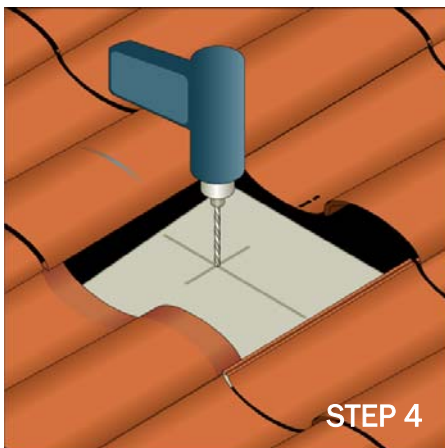

STEP 4

**STEP 4:** Drill several holes (if necessary) to locate the exact rafter center. A 3/16" pilot hole drill bit is recommended.

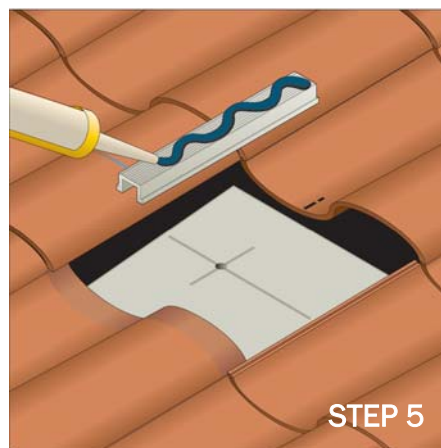

STEP 5

**STEP 5:** Insert the lag bolt and washer through the TileTrac® and apply fresh sealant to the base.



Roofing mastic/sealant must be applied per manufacturer's specifications. Mastic/sealant should be fresh and applied at room temperature, as necessary.



STEP 6

**STEP 6:** Install the lag bolt into the roof (cordless impact wrench recommended) using a 1/2" socket drive until the lag bolt is seated. **DO NOT OVERTIGHTEN.** The sealant should flow outward sealing any holes made to locate the rafter.



STEP 7

**STEP 7:** After bolting TileTrac® to the roof, slide the upper carriage into the correct position under the crown of the tile.



Before replacing tiles, be sure ALL holes have been properly sealed, including the original hole used to hold the tile in place.

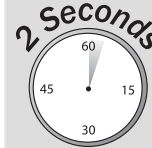

A Rotary Hammer Drill reduces concrete roof tile drill time to approx. 2 seconds. A hammer drill will dramatically increase drill time to over one minute. Use of a standard drill will increase time to approx. 10 minutes. See [www.prosolar.com/tiledrill.htm](http://www.prosolar.com/tiledrill.htm) for demonstration.



STEP 8

**STEP 8:** Replace the tile by lining up the snap lines, the tile is now ready to be marked and drilled.



STEP 9

**STEP 9:** Using a 3/8" carbide bit and a rotary hammer, drill through the crown of the tile at the intersection of the chalk line and the reference marks.



STEP 10

**STEP 10:** Insert the threaded shaft through the tile into the upper carriage. Bind two 3/8" nuts (provided) using two opposing 9/16" wrenches and tighten to 14 ft. lbs.

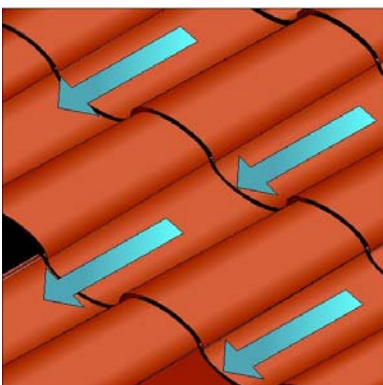

Water flows through the valley (lowest point) of the tile, not the crown (highest point), which virtually eliminates any chance of water leakage through the tile attachment. The crown of the tile is the strongest point and will not break when properly drilled. Avoid attaching/drilling in the valley of the tile to prevent water/debris build-up which may lead to leakage.



**STEP 11:** Apply UV rated sealant around the threaded shaft and compress with a 3/8" washer included in the kit. The 3/8" box-end wrench can be used for this.



**STEP 12:** Apply UV rated sealant around the top of the washer to complete the waterproof tile seal. Now the tile is completely waterproof.

## Step 3b: Attaching / Sealing TileTrac® (Composition Roof)

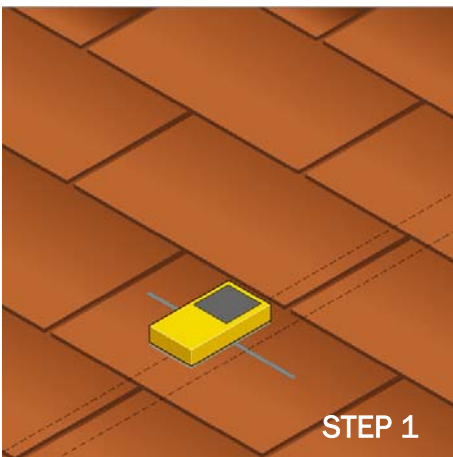

**STEP 1:** Using a precision stud finder, locate the absolute center of the rafter. Mark with a crayon/chalk. See section 3a *Install Tip* for additional methods for locating rafters.

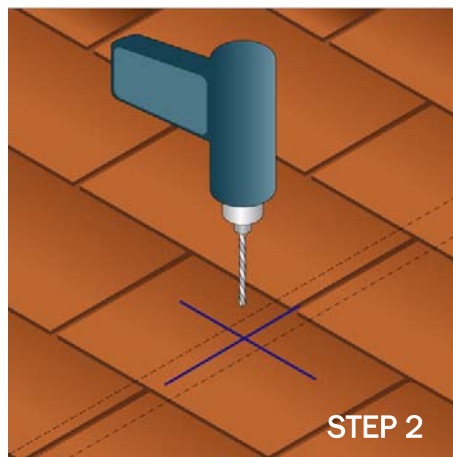

**STEP 2:** Drill a 3/16" pilot hole to depth of the lag bolt.

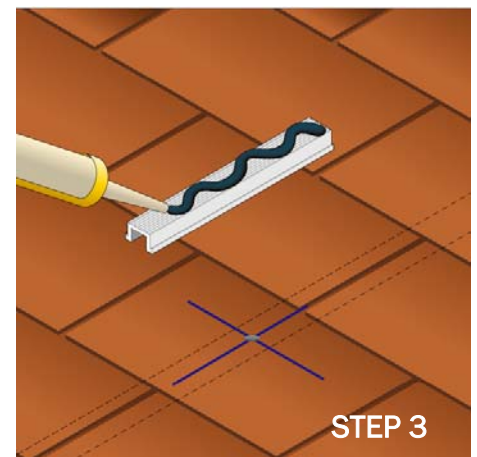

**STEP 3:** Apply a generous amount of fresh sealant (polyurethane based, such as Sikaflex 1-a recommended) to the base.



Use of a 1/4" carbide tipped drill bit for breaking through the rough composition shingle surface only (not for pilot hole) will avoid premature pilot hole drill bit wear. The use of two drills—one for breaking through surface, one for pilot hole drilling—to decrease drill time is recommended.



Roofing mastic/sealant must be applied per manufacturer's specifications. Mastic/sealant should be fresh and applied at room temperature, as necessary.

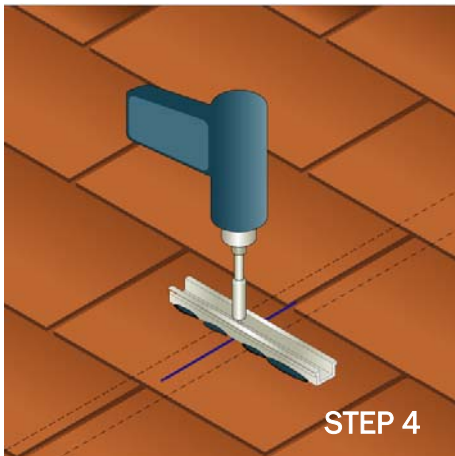

**STEP 4:** Install the lag bolt and washer into the roof (cordless impact wrench recommended) using a 1/2" socket drive until the lag bolt is seated. **DO NOT OVERTIGHTEN.** The sealant should flow outward sealing any holes that were made to locate the rafter.

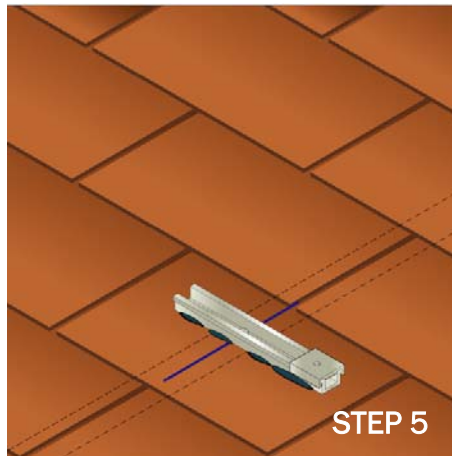

**STEP 5:** After bolting TileTrac<sup>®</sup> to the roof, slide the upper carriage into the desired position.

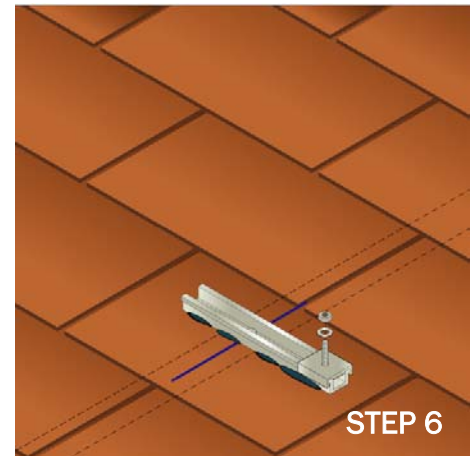

**STEP 6:** Thread the short cup head stud into the upper carriage with a hex key and tighten to 14 ft/lbs. The nut/washer combination will be installed after the support rail is in place.

Repeat steps 1-6 until all TileTrac<sup>®</sup> attachments are installed, then refer to the RoofTrac<sup>®</sup> installation guide for the support rail and module clamping installation steps.

## Step 5: Clean up / Quality Inspection

### Clean-Up:

Account for all tools and clean area as necessary.

### Quality Inspection:

Contractors are advised to perform a final attachment quality inspection prior to installing the RoofTrac<sup>®</sup> mounting system to ensure all attachments are properly fastened.



Make sure all installation crew members on the roof are mindful of protruding roof attachments to prevent tripping. All installation crew members should utilize proper safety equipment when installing a solar system.