

APPLICATION:

The patented SolarWedge[®] XD product line provides an easy-to-install and economical solution for a 5, 10 or 15 degree tilted roof mounted system. SolarWedge[®] XD integrates with Professional Solar's (ProSolar) patented "top-down" clamps and deep channel support rails. The system dramatically lowers installation and shipping costs while optimizing installed wattage on the roof.

Pat #6,360,491 and D547626

WARNING

All ProSolar products are engineered and tested to withstand stated specifications (as stated on published specification sheets) when installed properly. Failure to install properly may decrease the performance of the installation.

SAFETY

All regional safety requirements should be followed when installing ProSolar Products. All tools and equipment located on the roof should be secured to avoid falling object hazards. All equipment/tools should be properly maintained and inspected prior to use. Any exposed studs should be protectively capped to help avoid injury. This installation manual is intended for use by professional installers with a working knowledge of construction principles.

Symbol Legend

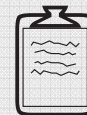

Explanation or Install Tip



Important Product Performance Information



Critical for Safety

Tool List

- Cordless drill with 1/4" diameter, long drill bit
- Cordless drill with 3/8" carbide (masonry) bit
- Cordless impact wrench (with appropriate lag bolt socket)
- 3/4" (18mm) titanium plated self starting #3 Unibit[®]
- 1/2" self starting #10 Unibit[®]
- 3/4" open-end wrench
- Adjustable pliers
- 9/16" Deep socket
- 1/2" box-end wrench
- Tape measure
- String line (chalk line)
- Lumber crayon
- Sharpie[®] pen
- Stiff paint brush
- FoamJack[®] drill guide
- Dead-blow hammer (approx. 21 oz)
- Precision stud sensor (recommended Zircon[®] I520)

Installation steps overview

- 1) System layout & chalk line marking
- 2) Locating structural members along chalk lines
- 3) Attaching/sealing SolarWedge® XD
- 4) Installing XD Splice
- 5) Fastening rail to SolarWedge® XD attachment
- 6) Installation of the clamping hardware/modules
- 7) Clean up/Quality Inspection

Step 1: System layout & chalk line marking

Prior to beginning attachment work, the system roof layout should be defined.

A drawing or sketch, prior to roof work, is recommended.

Upon finalizing layout, use chalk lines to mark support rail locations. The chalk lines will be used to align SolarWedge® XD attachment points.

Note: The rail distance from the end of the module will vary based on module size.

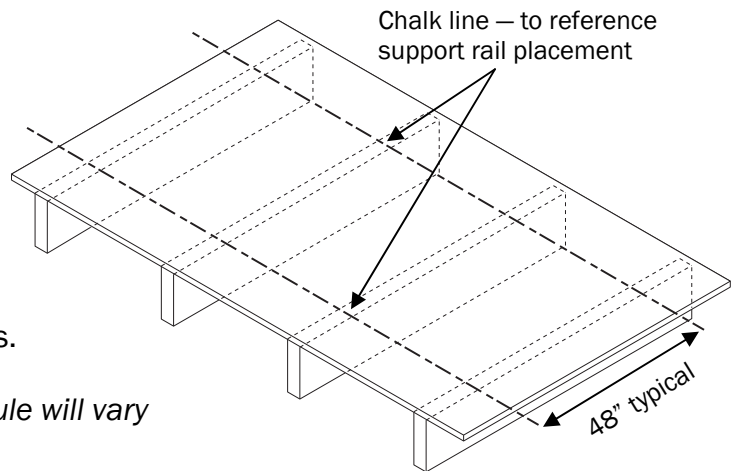

ProSolar does not recommend 8' attachment spacing on residential structures, as residential structures are typically not designed for longer spans. It is highly recommended to obtain proper structural engineering for loading of the structure before specifying a long-span mounting system.

Proper module/rail orientation—single array sample

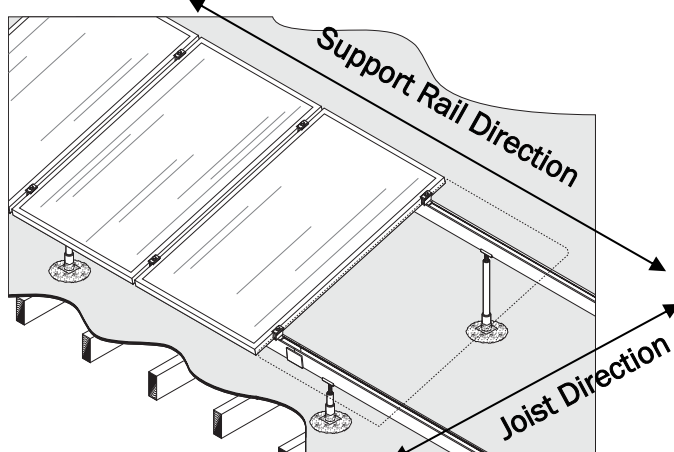

Clamps must secure the module on the **long end** of the frame. The span of the two support rails should be 48\".

EXAMPLE: (Using a 64\" long module)

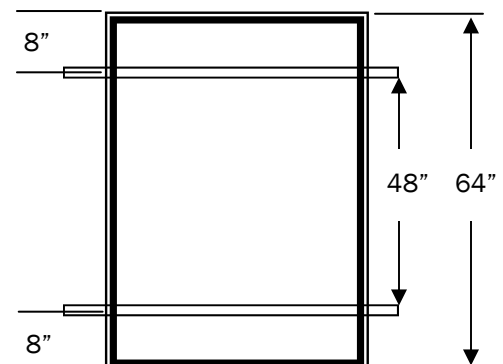

Step 2: Locating structural members along chalk lines

Finding initial reference structural member for a commercial flat roof:

- 1) Locating commercial roof landmarks is usually sufficient for finding the initial reference structural member. Landmarks include skylights, vents and air conditioning units, as these are normally beside known structural members.
- 2) Upon identifying the general location of the structural member, use a precision stud sensor or other preferred method to locate the center of the structural member.



Depending on the thickness of the roofing material the Zircon® stud sensor may accurately indicate the location of the structural member which significantly reduces location time.



In some structures, such as open warehouses, the landmarks and structural members are visible from below, which helps make locating structural members from the roof easier.



Alternate method of finding structural members (STEP 3):

Using a dead blow hammer, lightly tap perpendicular to the approximate structural member location until a solid sound is heard. The dead blow hammer impact directly above the structural member will emit a deeper sound.

- 3) Once the initial reference structural member center location is identified, measure the appropriate distance (96") to help approximate the next structural member/connection location.

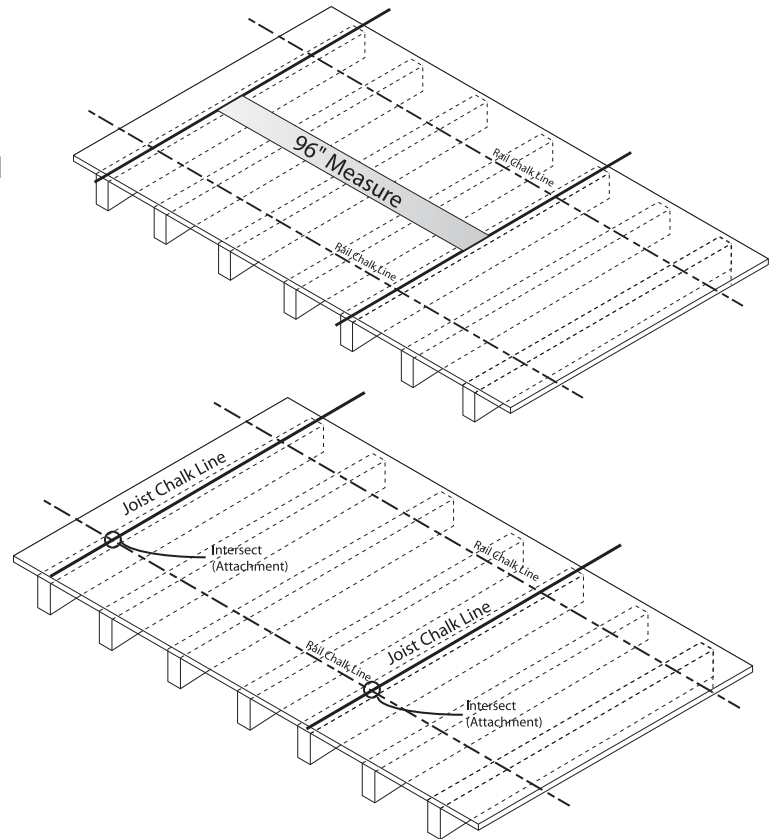

Step 3: Attaching / Sealing SolarWedge® XD



Mark (with lumber crayon) or account for ALL holes, including small nail holes, to ensure roof is properly sealed. Approximate average attaching/sealing time: 5 min. per attachment.



There are many sealant methods, including, but not limited to, sealing, flashing and foaming. The SolarWedge® XD is compatible with readily available, standard 1" diameter metal flashings (approx. 4-1/2" minimum flashing height). If foaming, post threads should be protected to avoid foam intrusion.

Sealant method illustrated in this installation sequence.

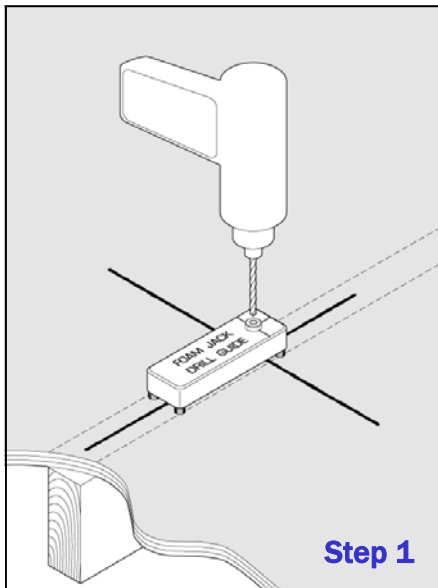

For 3/8" x 6" lag bolt applications

STEP 1a: Using a 3/8" carbide (masonry) bit, break through the cap sheet.

STEP 1b: Using the FoamJack® drill guide and a 1/4" dia. long drill bit, drill a hole in the center of the joist.

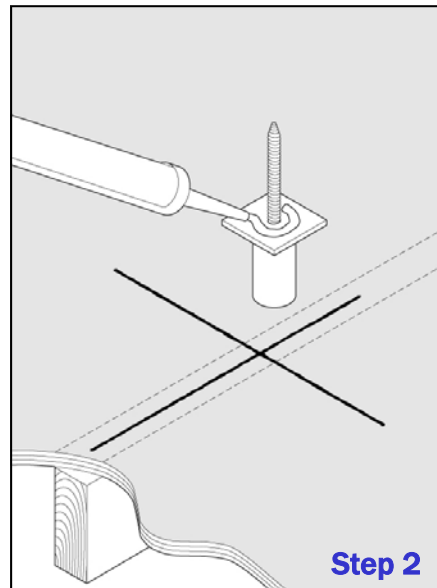

STEP 2: Apply a generous amount of roof sealant to the bottom of the seal plate of the SolarWedge® XD creating a circle around the lag bolt hole.

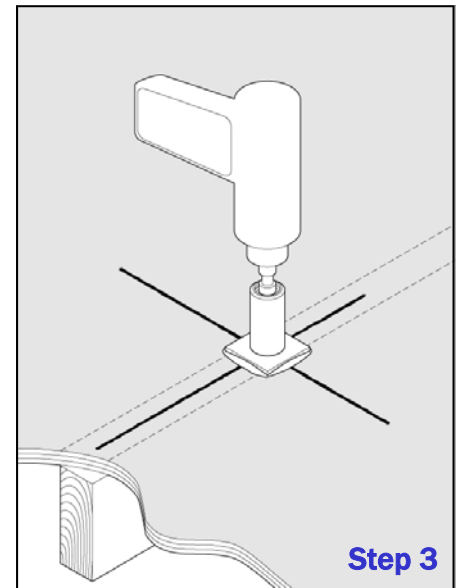

STEP 3: Using a cordless impact wrench and a 9/16" deep socket, install the bolt into the SolarWedge® XD base until seated. Allow the sealant to flow outward around the edges of the seal plate.



Using a carbide bit to break through the cap sheet will avoid premature dulling of the wood drill bit. Use two drills, one with a 3/8" carbide bit, one with a 1/4" long wood drill bit to save time.



Lag bolts are not included with the SolarWedge® XD products due to site (job) specific requirement variation. The installation manual references the use of 3/8" x 6" lag bolts. Consult your structural engineer for site (job) specific fastener requirements.

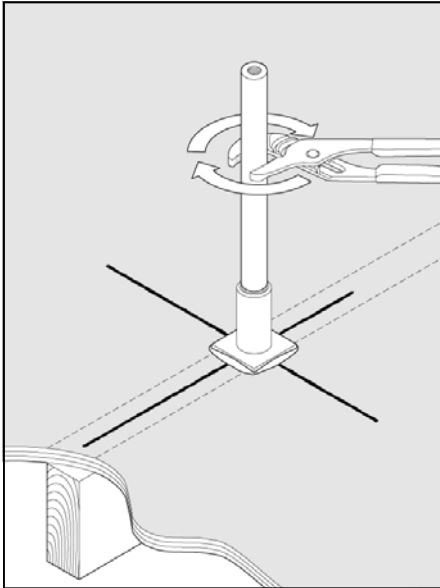

STEP 4: Install the post using an adjustable wrench. Turn wrench clockwise until fully secured. Avoid twisting the base while tightening.

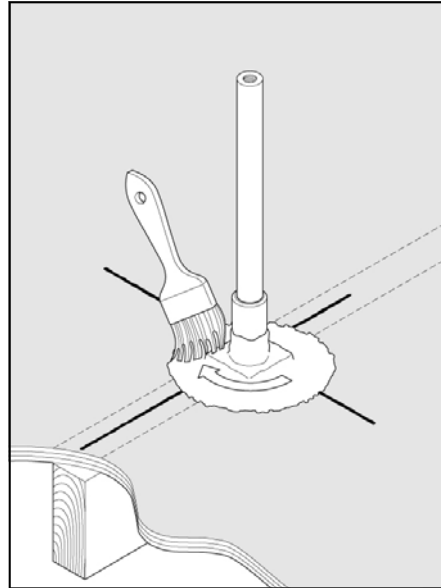

STEP 5: Seal the top of the seal plate with a layer of exterior rated roof sealant using a stiff paintbrush. Cover the entire base plate with the sealant, at least half the post and about 1-1/2" around the plate.

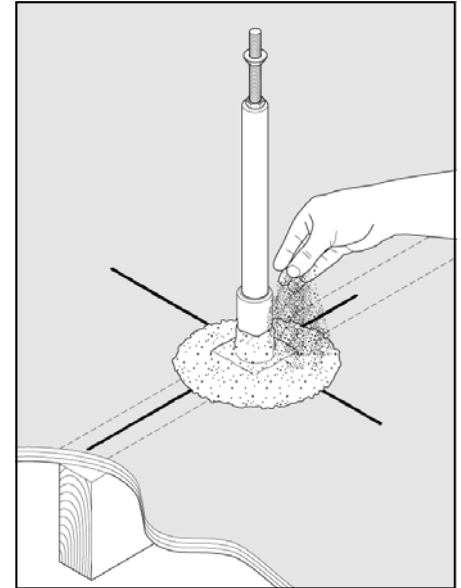

STEP 6: Using Play/Silica sand, cover the sealant. *This step prevents debris from sticking to the sealant while drying and gives it a clean, finished appearance.* **IMPORTANT: Do not install leveling kit hardware until support rail installation.**

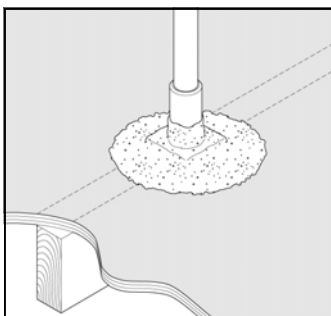

Seal

Using a high quality exterior rated sealant provides an economical and sound sealing method that takes seconds to apply. This method saves time and installation costs!

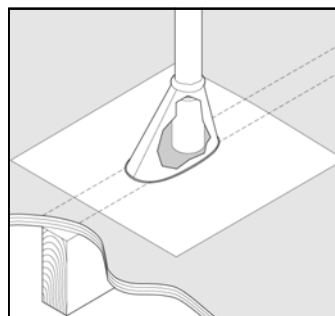

Flash

The SolarWedge® is compatible with readily available, standard 1" roof flashings.

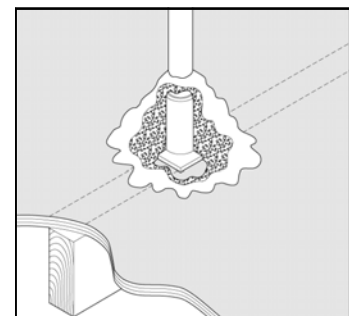

Foam

Using a 2-part hand-held or truck mounted foaming rig, you can create a "flashing" using high density roof foam!

Step 4: Installing XD Splice

Install XD Splice prior to installing support rails

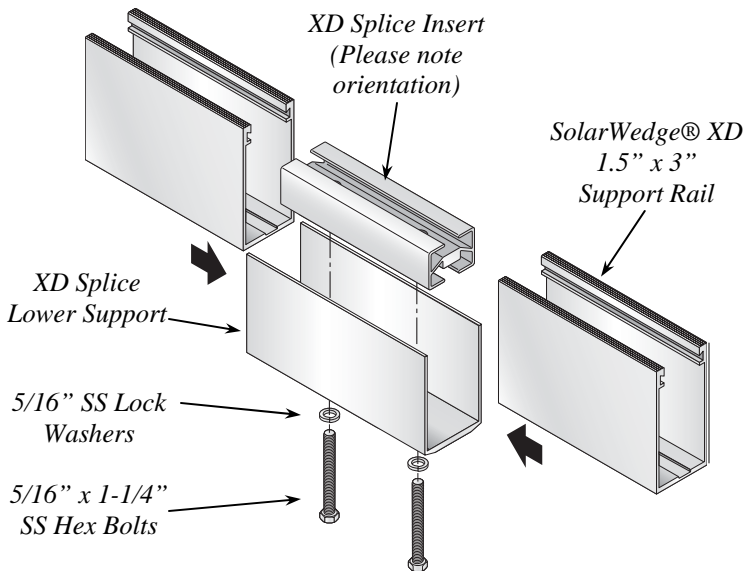

Pre-install splice kits for easier handling of support rails and to ensure support rail holes are properly aligned with your attachments. Install splice kits as illustrated to the left.

Turn the support rails upside-down and place the lower splice extrusion over the desired location. Be sure to allow for a 1/8" gap between support rails when planning your splice placement. Using a permanent marker, dot the location of the bolt holes of the lower extrusion on the support rail.

Using a Unibit® #10 Drill bit, drill through each support rail. These will be your bolt holes for the splice.

Turn the support rail right-side up and install the splice kit as illustrated to the left.



Unibit® Drill Bit

Compensates for approx. 1/4" drilled hole spacing inaccuracy
Short bit length prevents drilling through surface below support rail
Bit design prevents drill from twisting as commonly experienced with standard drill bits.

Unibit® 1/2" #10 - Used for Splice Kit

Unibit® 3/4" #3—Used for support rail/leveling hardware integration



Leave 1-1/4" hex bolts fastened when installed within 2" of an inter-module clamp.



Maximum of four rails can be spliced to allow for thermal expansion

Step 5: Fastening rail to SolarWedge® XD attachment

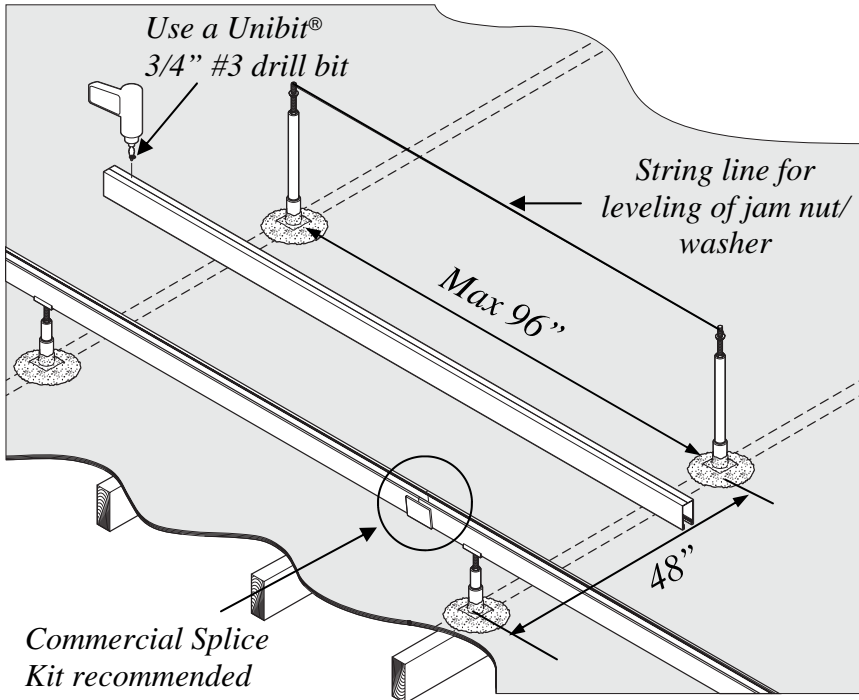

STEP 1: Using a string line from each end of the module array, level studs to desired position on roof (4" leveling stud must have at least 1" threaded into post).

STEP 2: Measure and mark hole placement on support rails by placing support rail upside down over studs—use a Sharpie® permanent marker to mark where drill holes should be placed. (Refer to RoofTrac® installation manual for more details).

STEP 3: Using the titanium plated 3/4" #3 self-starting Unibit® (sold separately) drill holes at stud centers along support rail.



Use a Unibit® 3/4" #3 titanium drill bit for drilling the support rail reduces drill time to a mere 3 seconds.

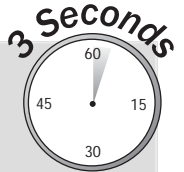

STEP 4: Install support rail using the SolarWedge® XD components as illustrated below.

SolarWedge® XD Installation Manual

Date Modified: 10/30/07

A

Level support rail

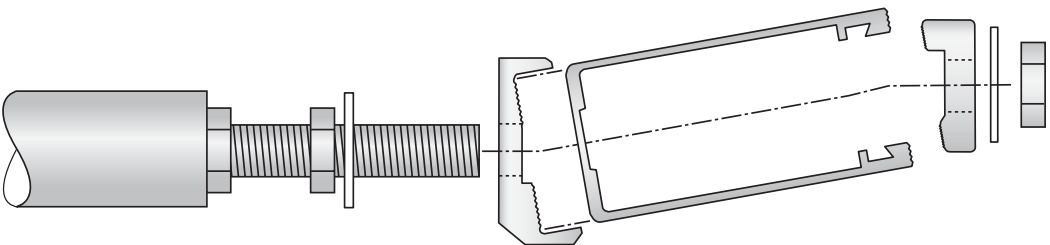

B

Hand-tighten top
1/2" Jam Nut/
washer

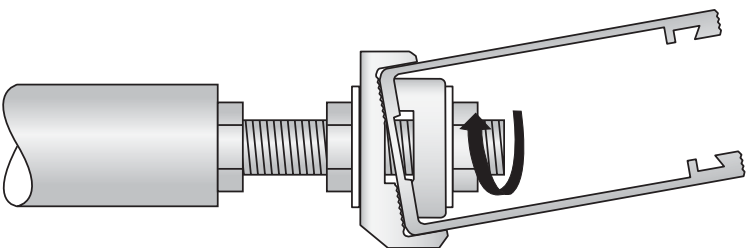

C

Using a 1/2" Box End wrench, tighten
the lower jam nut turning counter-
clockwise. Repeat for all attachment

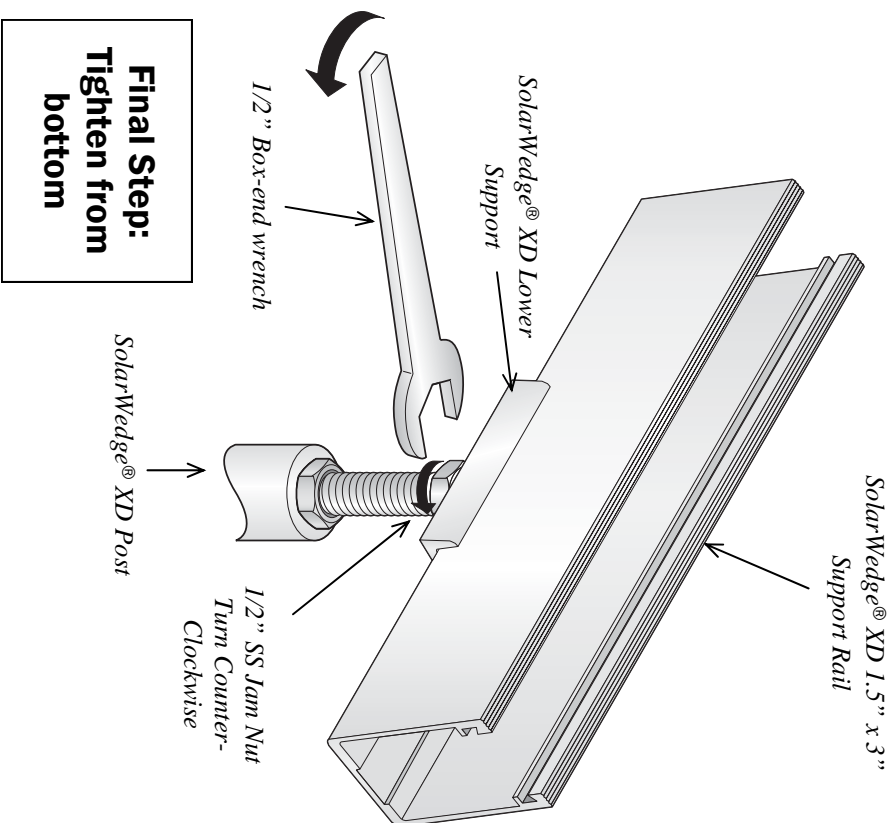

**Final Step:
Tighten from
bottom**

Step 6: Installation of the clamping hardware/modules

There are two sets of clamps; the outside clamps (end clamps) and the inter-module clamps that install between the modules.

Insert an end clamp at the end of each row of support rails. Hook the end clamps against the long end of the module and square off to the support rail. Tighten the clamps using a 1/2" box wrench or drive socket. **DO NOT OVER-TIGHTEN**, we recommend a maximum torque of 12 ft. lbs. to prevent damage to the module glass.

After the first module is secured, slide two inter-module clamp sets onto the first module. They are designed to remain captive in the channel allowing the installer to slide and align the next module. Repeat this procedure until all modules are installed onto the support rails. Upon installation of the last module, install the module end clamps to complete the installation.

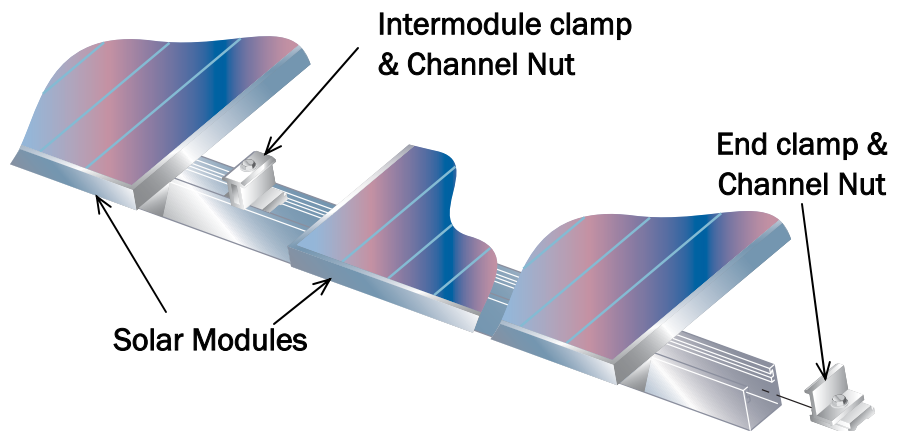
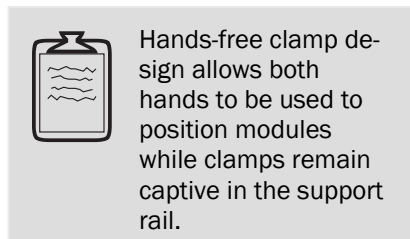
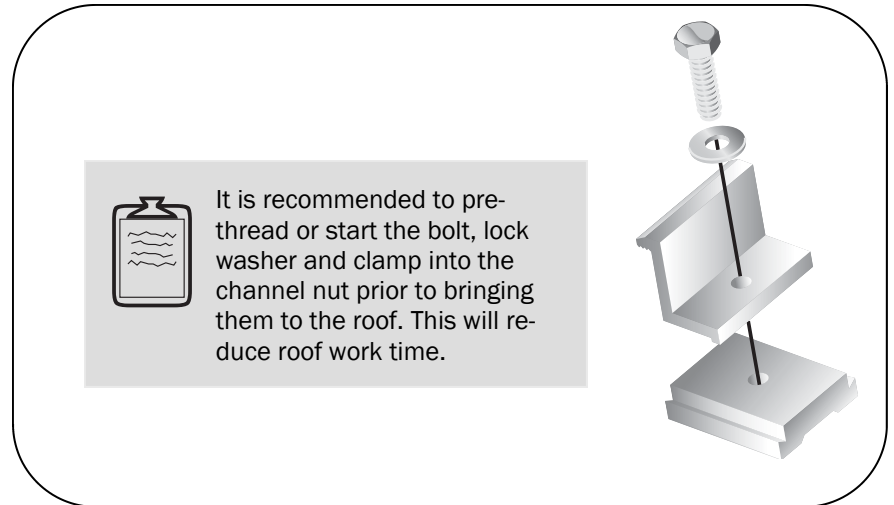

Step 7: Clean up / Quality Inspection

Clean Up:

Upon completing the attachment installation, account for all tools and clean area as necessary.

Quality Inspection:

It is recommended that each contractor perform a final attachment quality inspection prior to installing the RoofTrac® mounting system to ensure all attachments are properly fastened.



Make sure all installation crew members on the roof are mindful of installed roof attachments to prevent tripping. All installation crew members should utilize proper safety equipment when installing a solar system. (Harnesses, hard hats, gloves, proper no-slip footwear, etc.)