



**PV Ground-Fault
Detector Interrupter (GFDI)**
Installation Instructions



About OutBack Power Systems

OutBack Power Systems is a leader in advanced energy conversion technology. Our products include true sine wave inverter/chargers, maximum power point charge controllers, system communication components, as well as breaker panels, breakers, accessories, and assembled systems.

Notice of Copyright

PV Ground-Fault Detector Interrupter Installation Instructions

Copyright © 2008 All rights reserved.

Disclaimer

UNLESS SPECIFICALLY AGREED TO IN WRITING, OUTBACK POWER SYSTEMS:

- (a) MAKES NO WARRANTY AS TO THE ACCURACY, SUFFICIENCY OR SUITABILITY OF ANY TECHNICAL OR OTHER INFORMATION PROVIDED IN ITS MANUALS OR OTHER DOCUMENTATION.
- (b) ASSUMES NO RESPONSIBILITY OR LIABILITY FOR LOSS OR DAMAGE, WHETHER DIRECT, INDIRECT, CONSEQUENTIAL OR INCIDENTAL, WHICH MIGHT ARISE OUT OF THE USE OF SUCH INFORMATION. THE USE OF ANY SUCH INFORMATION WILL BE ENTIRELY AT THE USER'S RISK.

Date and Revision

December 18, 2008 900-0015-01-00 REV A

Contact Information

OutBack Power Systems

19009 62nd Ave. NE

Arlington, WA 98223

Phone (360) 435-6030

Fax (360) 435-6019

www.outbackpower.com

IMPORTANT SAFETY INSTRUCTIONS

KEEP THESE INSTRUCTIONS

This product is intended to be installed as part of a permanently grounded electrical system as shown in the wiring diagrams. The following important restrictions apply *unless superseded by local or national codes*:

- Ground equipment is marked with this symbol: 
- *The GFDI is designed for indoor installation or installation inside a weatherproof enclosure. It must not be exposed to rain.*
- Must use a UL approved crimp lug on the cable attached to the breaker stud.

NOTE: OutBack supplies a #2 AWG ring terminal with the GFDI and recommends a #2 AWG cable when the GFDI is connected to an 80 amp breaker. (#3 AWG is the minimum allowable in this application. See *Standards and Requirements*, page 3.)

Introduction

The OutBack Power Systems' Ground Fault Detector Interrupter (GFDI) is a safety device for a photovoltaic (PV) array. In the event that the array becomes shorted to ground, it disconnects the PV system from the batteries.

- The GFDI meets mandatory UL 1741 low-level ground-fault protection requirements for roof-mounted photovoltaic energy systems to prevent fires.
- The GFDI meets the requirements of the 2008 NEC section 690.5 (A) through (C) to reduce fire hazards when wired according to the wiring diagram contained in these instructions.

OutBack GFDI Products

- OBB-GFDI-80-150VDC-PNL (one 0.5 amp breaker ganged with one 80 amp breaker with common trip)
- OBB-GFDI-80D-150VDC-PNL (one 0.5 amp breaker ganged with two 80 amp breakers with common trip)
- OBB-GFDI-80Q-150VDC-PNL (one 0.5 amp breaker ganged with four 80 amp breakers with common trip)

FUNCTION

The GFDI consists of a single 0.5 amp breaker, mechanically connected to a combination of 1, 2, or 4 standard OutBack 80 amp breakers (see list on previous page).

- When a ground fault occurs, the 0.5 amp breaker will trip. Due to the common internal tripping mechanism, all the other breakers connected to the GFDI will also trip and shut power down.
- All power production from PV array charge controllers ceases when the breakers trip and remove their connection to the batteries.

Standards and Requirements

Code Requirements

All installations must comply with national and local electrical codes; professional installation is recommended. NEC requires ground fault protection for residential PV installations. For more information, see NEC 690.5.

DC and Battery-Related Installation Requirements

- *Shut off all DC breakers before connecting any wiring.*
- All wiring must be copper and rated at 75° C or higher.
- Use a minimum cable size of #3 AWG* for 80 amp breakers and #14 AWG for 0.5 amp breakers (NEC table 310.16).
- Torque breaker nuts to 35 inch-pounds/4.0Nm.

For installations above 30 degrees C, follow the correction factors at the bottom of NEC table 310.16 using 100 amps as the **baseline**.

In addition:

- The GFDI is only to be used with OutBack UL 1741 or UL 508A listed photovoltaic based products.
- The GFDI shall be the only bonding connection between grounding system and battery negative in the DC system.
- The GFDI is not intended for use in positive ground installations.

**UL1741 16.1.3 states: A wiring terminal or lead shall be rated and sized for connection to a field wiring conductor having an ampacity, based on Table 310.16 of the NEC, of no less than 125 percent of the RMS or dc current that the circuit carries during rated conditions. 80 amps X 1.25 = 100 amps, which requires #3 AWG wire (in ambient conditions of no more than 30 degrees C).*

LABELS AND WARNINGS

The GFDI comes with a number of warning and identification labels pre-installed by OutBack. The following two labels are installed by the end user or the installer.

WARNING!
ELECTRIC SHOCK HAZARD
IF A GROUND FAULT IS INDICATED,
NORMALLY GROUNDED CONDUCTORS
MAY BE UNGROUNDED AND ENERGIZED

Install this label to the battery enclosure/cabinet.

NOTE: "When the photovoltaic system also has batteries, the same warning shall also be applied by the installer in a visible location at the batteries." (NEC 690.5)

**PV ARRAY GROUND FAULT
DETECTOR INTERRUPTER**

150 VDC, 80 ADC, 0.5 ADC GROUND
FAULT DETECTION

OBB-GFDI-80-150VDC-PNL
 OBB-GFDI-80D-150VDC-PNL
 OBB-GFDI-80Q-150VDC-PNL

CAUTION: RISK OF ELECTRIC SHOCK
NORMALLY GROUNDED CONDUCTORS MAY BE
UNGROUNDING AND ENERGIZED WHEN A GROUND-FAULT
IS INDICATED.

Many types of ground-fault detection and interruption equipment
break the negative-to-ground bond to interrupt the fault currents,
and the now ungrounded PV negative conductor generally is
open-circuit voltage below the ground reference 150 volts.

USE A MINIMUM OF 3 AWG 75°C COPPER CONDUCTORS
Torque 1/4 - 20 breaker studs to 35 In-lbs (4.0 Nm)

OutBack
Power Systems

Designed and assembled in
Arlington, WA USA
www.outbackpower.com

Install this label on the outside of the panel box location of the GFDI.

Installation Instructions

- Insert the GFDI into the breaker mounting bracket.
- Insert and hand-tighten the GFDI's mounting screws.
 - CAUTION — overtightening can damage the GFDI.
- With all system power off, attach the ground and negative wires to their respective bus bars and to the back of the GFDI.
 - The ground wire goes to the top of the 0.5 amp breaker.
 - The negative wire goes to the bottom of the same breaker.(See Figures 1 and 2.)

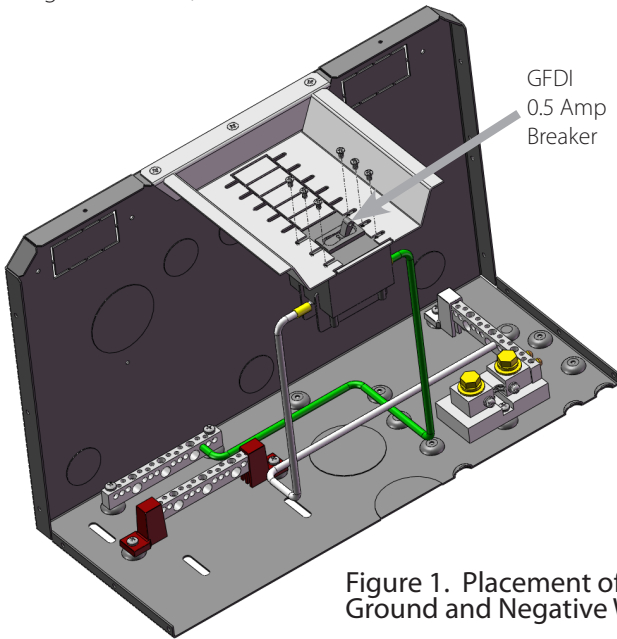

Figure 1. Placement of Ground and Negative Wires

- With all system power off, make the connections to the individual 80-amp breakers. The specifics will vary with the GFDI model and installation type.
 - Attach the "Battery +" wire from one charge controller to the top of one 80-amp breaker. (See Figure 2.)
 - Attach a wire from your battery positive breaker or battery positive bus bar to the bottom of the same 80-amp breaker. (See Figure 2.)
 - Repeat these steps for additional charge controllers. The GFDI should have one 80-amp breaker for each controller.
- Torque all GFDI wires to 35 inch-pounds/4.0 Nm.

Once all breakers are turned on, the 0.5 amp breaker of the GFDI connects the grounding system to the battery negative, while the 80 amp breaker(s) connect the battery to the charge controllers (see Figure 2).

- Normal operation of the GFDI is indicated by the green breaker lever in the up/on position.
- In normal operation, grounding system is bonded directly to battery negative through the 0.5 amp breaker, and the charge controllers receive battery voltage.
- The 0.5 breaker detects a ground fault by detecting current flow between chassis ground and battery negative.
- In the event of a ground fault, flow of fault current is interrupted and indicated by the green breaker lever in the down/off/tripped position.
- When the 0.5 amp breaker opens, the other GFDI poles mechanically connected to it will open at the same time. This disconnects voltage between all charge controllers and the batteries.
- If the breakers trip, the negative-to-ground bond remains established through the 43 kilohm, 5 Watt resistor in parallel to the GFDI breaker.

NOTE: The GFDI shall not be installed as a PV disconnect. The 80 amp breakers of the GFDI are intended only for connecting the battery positive to the charge controllers.

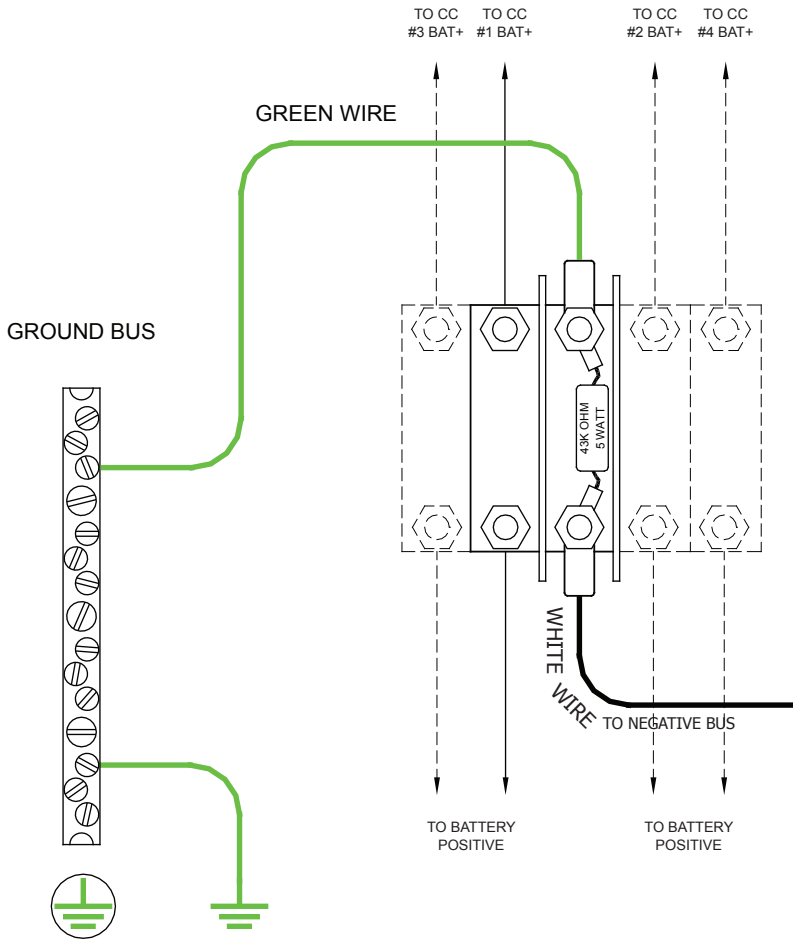

Figure 2. Wiring Diagram, Rear View

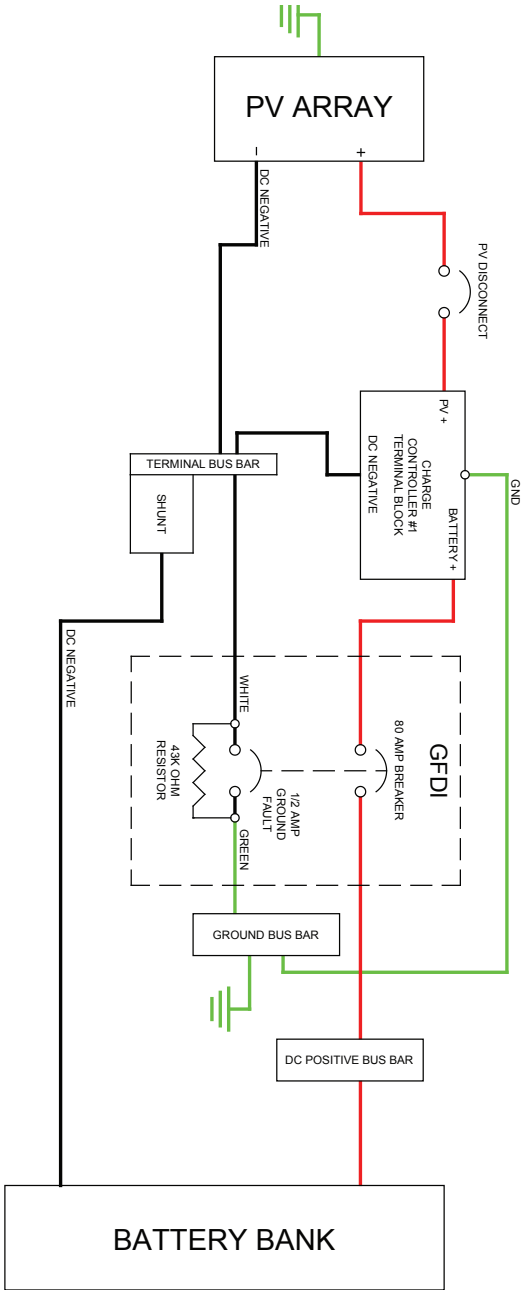

Figure 3. OBB-GFDI-80-150VDC-PNL Two-Position Installation

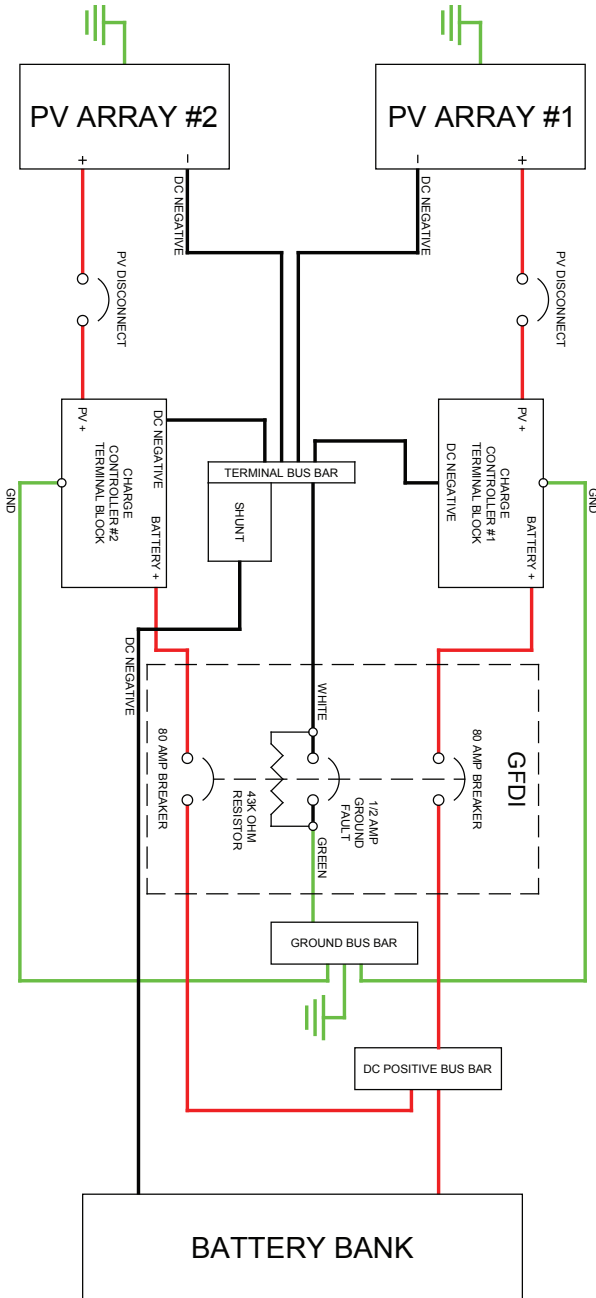

Figure 4. OBB-GFDI-80D-150VDC-PNL Three-Position Installation

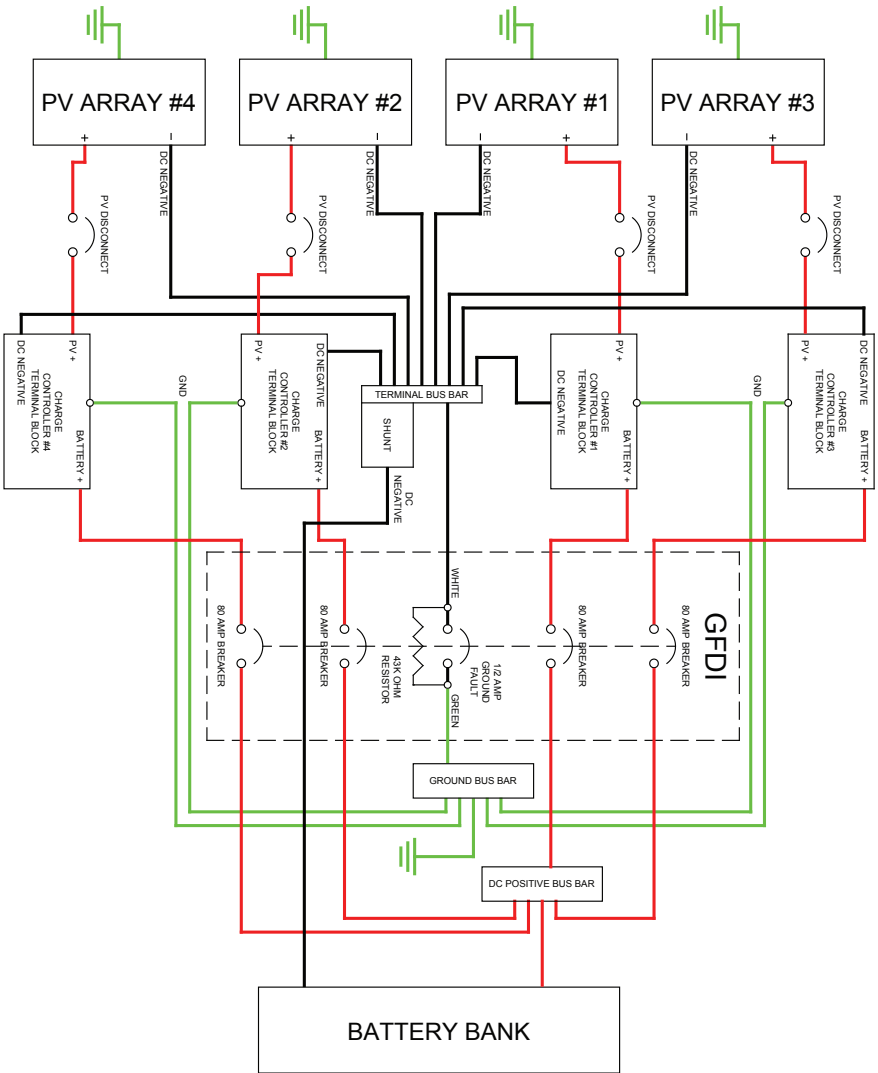

Figure 5. OBB-GFDI-80Q-150VDC-PNL Four-Position Installation



Corporate Office
19009 62nd Avenue NE
Arlington, WA USA
(+1) 360-435-6030

www.outbackpower.com

European Sales Office
C/ Castelló, 17
08830 - Sant Boi de Llobregat
BARCELONA, España
Phone: +34.93.654.9568

900-0015-01-00 REV A