

PERC

Series



Module Installation & User Manual

REV: 0 | Release Date: 9/9/2022

MISSION SOLAR
ENERGY



Module Types

MSExxxSX9W

MSExxxSX9Z

MSExxxSX9R

www.missionsolar.com

TABLE OF CONTENTS

1.0	DISCLAIMER	2
2.0	HANDLING AND USE	2
3.0	LIMITATION OF LIABILITY AND LIMITED REMEDIES	2
4.0	GENERAL INSTRUCTIONS	2
5.0	SAFETY	3
5.1	General Warning	3
5.2	Mechanical	3
5.3	Electrical Shock Hazard	3
5.4	Fire	3
6.0	OPERATING CONDITIONS	4
6.1	Temperature	4
6.2	INSTALLATION CONDITION	4
7.0	UNPACKING & STORAGE	5
7.1	General Instructions.....	5
7.2	Unpacking Instructions	6
8.0	PRODUCT SPECIFICATION	8
	Table 1: Electrical Ratings of MSE PERC 72 (9BB, White backsheet) Module Series.....	8
	Table 2: Electrical Ratings of MSE PERC 72 (9BB, Black Backsheet) Module Series	8
	Table 3: Electrical Ratings of MSE PERC 66 (9BB, Black Backsheet) Module Series	8
	Table 4: Electrical Ratings of MSE PERC 60 (9BB, Black Backsheet) Module Series	9
	Table 5: Electrical Ratings of MSE PERC 66 (9BB, White Backsheet) Module Series.....	9
	Table 6: module Temperature coefficient.....	9
9.0	MECHANICAL INSTALLATION	9
9.1	Ground Mount	10
9.2	Roof Mount	10
9.3	Pole Mount	10
9.4	MOUNTING OPTIONS.....	10
	Table 7: Design Load As Specified By UL61730	11
	Figure 1: Bolt Method	11
	Figure 2: Clamp Method.....	11
10.0	GROUNDING INSTRUCTIONS	13
10.1	WEEB-UIR.....	14
11.0	ELECTRICAL INSTALLATION	15
11.1	Local / National Code and Local Regulation.....	15
11.2	Wiring.....	15
11.3	Connectors	16
11.4	Diodes	16
12.0	MAINTENANCE	16
12.1	Visual Inspection	16
12.2	Cleaning.....	16

MISSION SOLAR ENERGY LLC

ELECTRONIC versions are uncontrolled except when accessed directly from document control directory. Printed copies are uncontrolled unless verified against online document.
COPYRIGHT 2020 MISSION SOLAR ENERGY LLC, ALL RIGHTS RESERVED

1.0 DISCLAIMER

This manual is provided on an “as is” basis without warranty, covenant or representative of any kind, express or implied, including the warranties of merchantability or fitness for a particular purpose. Mission Solar Energy uses its best efforts to ensure the accuracy of the contents of this manual; however, Mission Solar Energy is not responsible for the accuracy of said contents or results of your use of the same. Under no circumstances will Mission Solar Energy be liable to you or any third party for damages arising under any legal theory including contract, tort, negligence or strict liability or for direct, indirect, special, consequential; or punitive damages of any kind, including lost profits. Mission Solar Energy reserves the right to make changes without further notice to this manual and to any modules. Mission Solar Energy does not convey any license under its intellectual property rights. Mission Solar Energy assumes no responsibility for any infringement to patents or other rights of third parties that may result from use of this manual or related module.

2.0 HANDLING AND USE

Mission Solar Energy shall not be liable for, and buyer shall indemnify, defend and hold harmless Mission Solar Energy, its affiliates and their respective officers, directors, employees, representatives and agents (“indemnities”) from and against, any and all claims, losses, liabilities, costs and expenses (including attorneys' fees) (“claims”) arising out of or resulting from the handling, use, processing, alteration, distributions, sale or marketing of modules and this manual, or any other action or inaction with regard to the modules and this manual, in each case after the delivery thereof to buyer; provided however, that buyer shall not be liable to Mission Solar Energy for damages directly caused by the sole negligence of Mission Solar Energy. Buyer’s obligations under this section shall survive the termination, cancellations or expiration of all orders delivered under these terms and the cessation of any business transaction between Mission Solar Energy and buyer.

3.0 LIMITATION OF LIABILITY AND LIMITED REMEDIES

In no event will Mission Solar Energy be liable to buyer for any lost or prospective profits, indirect, incidental, consequential, special, exemplary or punitive damages, including, without limitation, lost earnings, or business interruption, whether or not based upon Mission Solar Energy’s negligence, breach of warranty, strict liability, in tort or any other cause of action. Buyer’s exclusive remedy VIS-À-VIS Mission Solar Energy or any other cause if action related to the modules and this manual is at Mission Solar Energy’s option limited to (i) replacement of the non-conforming modules; or (ii) refund to buyer of the portion of the purchase price attributable to such non-conforming modules. In no event shall Mission Solar Energy’s cumulative liability exceed the price of modules sold which was the direct cause of the alleged loss, damage or injury.

4.0 GENERAL INSTRUCTIONS

This manual provides important safety instructions regarding installation, maintenance and handling of Mission Solar Energy photovoltaic modules. All the users should read this manual carefully and follow the instructions strictly. The installation of solar modules requires specialized skills and experience and should only be performed by licensed professionals.

5.0 SAFETY

5.1 GENERAL WARNING

You must understand and follow all applicable local, state and federal regulations in addition to standards for building construction, electrical design, fire and safety. Check with local authorities to determine applicable permitting requirements before attempting to install or maintain PV modules.

- Module interconnects pass direct current (DC) when exposed to sunlight or other light sources.
- Contact with electrically active parts of the module, such as terminals, can result in injury or death, whether the module is connected or disconnected.
- Never wear metallic rings, watch bands, ear, nose or lip rings or other metallic devices when installing or trouble shooting a photovoltaic system.
- Mission Solar PV modules are intended for use in terrestrial applications only with an altitude of less than 2000m, thus excluding aerospace or maritime conditions or use with sunlight concentration. Excluded applications include, but are not limited to, installations where modules are likely to come in contact with any salt water or where likely to become partially or wholly submerged in fresh or salt water. It is advised that modules be installed at least 500m away from the sea.

5.2 MECHANICAL

- Rooftop PV systems should only be installed on dwellings that have been formally analyzed for structural integrity, and confirmed to be capable of handling the additional weighted load of PV system components including PV modules by a certified building specialist or engineer. For your safety, do not attempt to work on a rooftop until safety precautions have been identified and taken, including without limitation fall protection measures, ladders or stairways, and personal protective equipment (PPE).
- For your safety, do not install or handle PV modules under adverse conditions, including and without limitation - strong or gusty winds and wet or frosted roof surfaces.
- The flat-plate PV module construction consists of a laminated assembly of solar cells encapsulated within an insulating material with a rigid glass surface and an insulated substrate. The laminated assembly is supported by an aluminum frame that is also used for mounting the module.

5.3 ELECTRICAL SHOCK HAZARD

- PV modules can produce current and voltage when exposed to light of any intensity. Electrical current increases with higher light intensity.
- DC voltage of 30 Volts or higher is potentially lethal. Contacting the live circuitry of a PV system operating under light can result in lethal electric shock.
- Use insulated tools and do not wear metallic jewelry while working with PV modules.

WARNING



- In order to avoid arcing and electrical shock, do not disconnect electrical connections under load.
- Faulty connections can also result in arcing and electrical shock.
- Keep connectors dry and clean; ensure that they are in proper working condition.
- Never insert metallic objects into the connectors, or modify them in any way in order to secure an electrical connection.
- Modules must be handled with care. If the front glass is broken or if the polymer back-skin is torn, contact with any module surface or the frame can produce electrical shock, particularly when the module is wet.
- Do not touch or handle PV modules with broken glass, separated frames or a damaged back sheet unless the PV modules are first disconnected and you are wearing proper PPE.
- Broken or damaged modules must be disposed of properly.
- Avoid handling PV modules when they are wet unless cleaning the PV modules as directed in this manual. **See 12.2 Cleaning.**
- Never touch electrical connections that are wet without protecting yourself with insulated gloves. Artificially concentrated light should not be directed on the module or panel.

5.4 FIRE

- Mission Solar Energy modules hold PV Type 1 fire rating in accordance with the UL 61730 standard.
- The fire rating of this module is valid only when mounted in the manner specified in the mechanical mounting instructions. See 9.0 Mechanical Installation
- PV modules are electricity generating devices that may affect the fire safety of a building.
- The use of improper installation methods and/or defective parts may result in the unexpected occurrence of an electrical arc during operation.
- The recommended standoff height is no less than 150mm (6 inches). If other mounting means are employed this may affect the fire class ratings. A minimum slope of 5in/ft. for installation over a roof is required to maintain the class C fire rating. Modules must be mounted over a fire resistant roof covering rated for the application.
- In order to mitigate the risk of fire in this event, PV modules should not be installed near flammable liquids, gases and/or locations with hazardous materials.
- In the event of a fire, PV modules may continue to produce a dangerous voltage, even if they have been disconnected from the inverter, have been partly or entirely destroyed, or the system wiring has been compromised or destroyed.
- In the event of fire, inform the fire crew about the particular hazards from the PV system, and stay away from all elements of the PV system during and after a fire until the necessary steps have been taken to make the PV system safe.

6.0 OPERATING CONDITIONS

6.1 TEMPERATURE

All the modules must be mounted in environments that ensure they operate within the following minimum and maximum ambient air temperatures:

- **Minimum ambient air temperatures:** -40°C (-40°F)
- **Maximum ambient air temperatures :** +40°C (104°F)

6.2 INSTALLATION CONDITION

Orient the module correctly. Mount the modules with the junction box in the uppermost position and hang the wires downwards to avoid the ingress of water. For optimal module performance install PV modules facing true south in northern latitudes and true north in southern latitudes. Shading will reduce electrical production and can prematurely degrade the viability of the solar module. This installation is applicable when the module is in portrait orientation. The modules have been evaluated by UL standards for mounting using the recommended mounting positions.



Photo Credit:GoSmart

MISSION SOLAR ENERGY LLC

ELECTRONIC versions are uncontrolled except when accessed directly from document control directory. Printed copies are uncontrolled unless verified against online document.

COPYRIGHT 2020 MISSION SOLAR ENERGY LLC, ALL RIGHTS RESERVED

7.0 UNPACKING & STORAGE

7.1 GENERAL INSTRUCTIONS



Store modules in an environment consistent with prudent solar industry practices, including, storage in dry conditions such that modules (or any part thereof) are not immersed in water.



Do not allow children or unauthorized persons near the installation site or storage area of modules.



Do not use forklifts with less than 72 inch forks to handle module pallet.



Unpack the module pallet with care and follow the unpacking steps in this manual. Be careful when unpacking, transporting and storing the modules.



Do not carry a module by its wires or junction box. At least two or more people are recommended to carry the module for safe handling.



Do not place modules directly on top of each other and prevent modules from touching one another.



Do not place excessive loads on the module or twist the module frame.



Do not stand, step, walk and/or jump on any part of the module.



Do not carry the module above the head.



Do not drop or place objects such as tools on the modules.



Do not mark the modules with sharp instruments.



Particular attention should be taken to avoid module back sheet contact with sharp objects. Scratches may directly affect product safety.



Do not leave a module unsupported or unsecured.



Do not change the wiring of bypass diodes.



Keep all electrical contacts clean and dry.



Modules may have sharp frame corners, use of puncture and cut-resistant gloves is recommended.

7.2 UNPACKING INSTRUCTIONS

Always wear Proper PPE when handling MSE Panels



Prior to unpacking, ensure pallet is set on a level surface and proper PPE is equipped by all personnel. Proper PPE for unpacking includes but is not limited to eye protection, cut-resistant gloves and steel-toe footwear.



Cut the two green strips of banding material with scissors. These strips are under high tension and will snap when cut. Eye protection is highly recommended.



Lift the pallet lid and set it away from unpacking area.

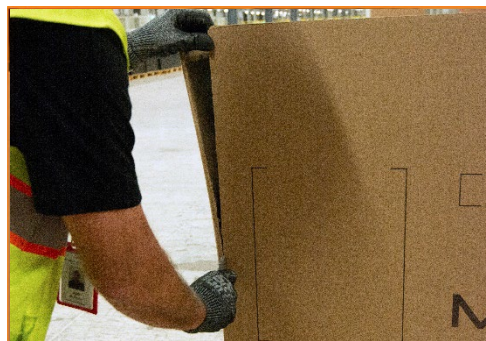

Using a box cutter, carefully cut along the corner from the top to the middle of the box on the packing slip side. Ensure the blade stays on the outside and does not cut through the white corner protectors.

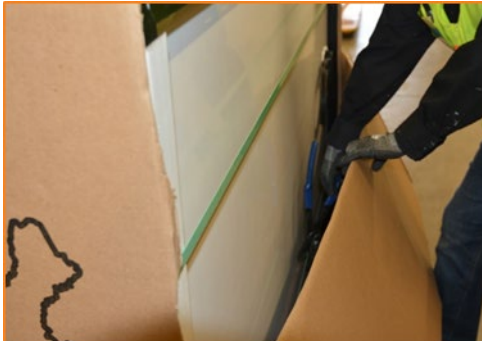

After both corners have been cut, fold the lengthwise side of the box halfway down allowing easy access to the modules. Cut the internal banding material as well being careful to avoid contact with the modules.



Peel back sides of box to allow for the additional access to modules.

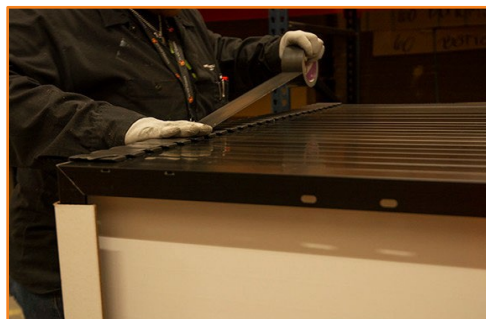

(Optional) Apply no-residue tape across the plastic corner clips to provide additional support to stack as modules are removed.



(Optional) Tape must reach at least 6 inches down on opposite side of box to maintain hold.



Remove white corner protectors.

MISSION SOLAR ENERGY LLC

ELECTRONIC versions are uncontrolled except when accessed directly from document control directory. Printed copies are uncontrolled unless verified against online document.
COPYRIGHT 2020 MISSION SOLAR ENERGY LLC, ALL RIGHTS RESERVED

Always wear Proper PPE when handling MSE Panels

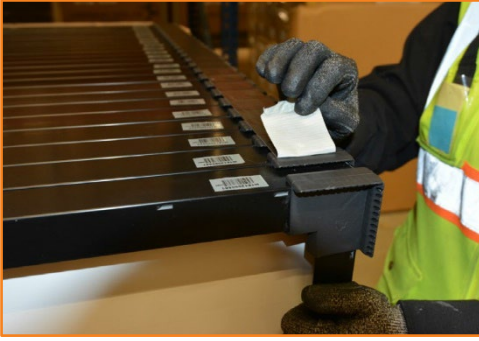

(Optional) If tape has been used to provide additional support to module stack, peel tape back as needed to remove individual modules.



The first module must be separated and pulled out with additional care so as to not scratch the modules. Continue removing modules by peeling back tape, moving the module forward and pulling it up.



When four modules remain, the stack will inherently become prone to tipping over. At this point, ensure two personnel are available to secure the stack.



Slide all of the remaining modules to the front of the box.



Carefully lower modules down to a horizontal position with the glass side down.



Remove box sleeve allowing easy access to remaining modules from the horizontal stack.

MISSION SOLAR ENERGY LLC

ELECTRONIC versions are uncontrolled except when accessed directly from document control directory. Printed copies are uncontrolled unless verified against online document.

COPYRIGHT 2020 MISSION SOLAR ENERGY LLC, ALL RIGHTS RESERVED

8.0 PRODUCT SPECIFICATION

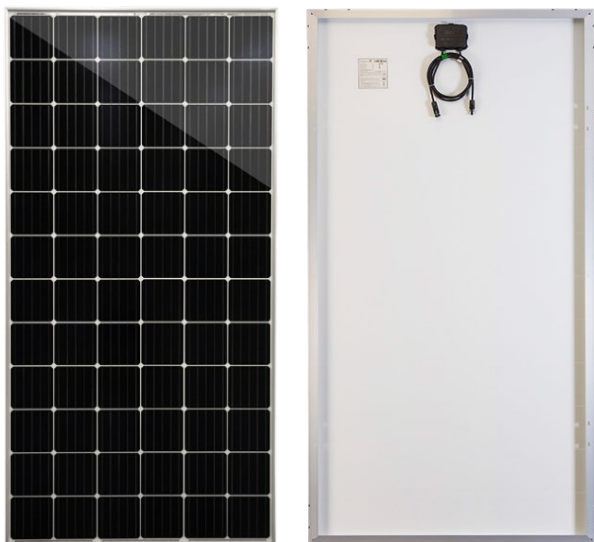

Mission Solar PV Modules have been certified to UL61730 for a maximum design load on the back of the module of up to 2400Pa and a maximum design load on the front of the module of up to 3600Pa.

The performance of solar modules is defined on the standard test conditions (STC). These conditions define performance at an incident sunlight of 1000 W/m², a module temperature of 25 ± 2°C and AM of 1.5 (AM = Air Mass) as per IEC60904-3. The air mass determines the radiation impact and the spectral combination of the light arriving on the earth's surface.

TABLE 1: ELECTRICAL RATINGS OF MSE PERC 72 (9BB, WHITE BACKSHEET) MODULE SERIES

Parameters			MSE420SX9W	MSE425SX9W	MSE430SX9W	MSE435SX9W	MSE440SX9W
Power Output	P _{max}	Wp	420	425	430	435	440
	Tolerance	%	-0/+3	-0/+3	-0/+3	-0/+3	-0/+3
Open Circuit Voltage	V _{oc}	V	48.90	49.04	49.26	49.40	49.55
Short-Circuit Current	I _{sc}	A	11.37	11.42	11.47	11.50	11.54
Rated Voltage	V _{mp}	V	39.17	39.44	39.59	39.92	40.20
Rated Current	I _{mp}	A	10.72	10.78	10.86	10.90	10.95
	Fuse rating	A	20	20	20	20	20
	Max. System Voltage	V	1,500	1,500	1,500	1,500	1,500

TABLE 2: ELECTRICAL RATINGS OF MSE PERC 72 (9BB, BLACK BACKSHEET) MODULE SERIES

Parameters			MSE415SX9Z	MSE420SX9Z	MSE425SX9Z	MSE430SX9Z	MSE435SX9Z
Power Output	P _{max}	Wp	415	420	425	430	435
	Tolerance	%	-0/+3	-0/+3	-0/+3	-0/+3	-0/+3
Open Circuit Voltage	V _{oc}	V	48.71	48.85	49.14	49.28	49.42
Short-Circuit Current	I _{sc}	A	11.11	11.15	11.19	11.24	11.31
Rated Voltage	V _{mp}	V	39.50	39.69	40.01	40.32	40.34
Rated Current	I _{mp}	A	10.51	10.58	10.62	10.66	10.78
	Fuse rating	A	20	20	20	20	20
	Max. System Voltage	V	1,500	1,500	1,500	1,500	1,500

TABLE 3: ELECTRICAL RATINGS OF MSE PERC 66 (9BB, BLACK BACKSHEET) MODULE SERIES

Parameters			MSE380SX9R	MSE385SX9R	MSE390SX9R	MSE395SX9R	MSE400SX9R
Power Output	P _{max}	Wp	380	385	390	395	400
	Tolerance	%	-0/+3	-0/+3	-0/+3	-0/+3	-0/+3
Open Circuit Voltage	V _{oc}	V	44.65	44.78	45.04	45.18	45.33
Short-Circuit Current	I _{sc}	A	11.11	11.15	11.19	11.24	11.31
Rated Voltage	V _{mp}	V	36.18	36.38	36.68	36.99	37.07
Rated Current	I _{mp}	A	10.50	10.58	10.63	10.68	10.79
	Fuse rating	A	20	20	20	20	20
	Max. System Voltage	V	1,000	1,000	1,000	1,000	1,000

MISSION SOLAR ENERGY LLC

ELECTRONIC versions are uncontrolled except when accessed directly from document control directory. Printed copies are uncontrolled unless verified against online document.

COPYRIGHT 2020 MISSION SOLAR ENERGY LLC, ALL RIGHTS RESERVED

TABLE 4: ELECTRICAL RATINGS OF MSE PERC 60 (9BB, BLACK BACKSHEET) MODULE SERIES

Parameters			MSE340SX9T	MSE345SX9T	MSE350SX9T	MSE355SX9T	MSE360SX9T
Power Output	P_{max}	Wp	340	345	350	355	360
Tolerance		%	-0/+3	-0/+3	-0/+3	-0/+3	-0/+3
Open Circuit Voltage	V_{oc}	V	40.47	40.59	40.71	40.95	41.07
Short-Circuit Current	I_{sc}	A	11.05	11.11	11.15	11.21	11.24
Rated Voltage	V_{mp}	V	32.54	32.82	33.05	33.38	33.63
Rated Current	I_{mp}	A	10.45	10.51	10.59	10.64	10.70
Fuse rating		A	20	20	20	20	20
Max. System Voltage		V	1,000	1,000	1,000	1,000	1,000

TABLE 5: ELECTRICAL RATINGS OF MSE PERC 60 (9BB, WHITE BACKSHEET) MODULE SERIES

Parameters			MSE350SX9K	MSE355SX9K	MSE360SX9K	MSE365SX9K
Power Output	P_{max}	Wp	350	355	360	365
Tolerance		%	-0/+3	-0/+3	-0/+3	-0/+3
Open Circuit Voltage	V_{oc}	V	40.75	40.87	41.11	41.23
Short-Circuit Current	I_{sc}	A	11.37	11.42	11.48	11.53
Rated Voltage	V_{mp}	V	32.65	32.88	33.11	33.41
Rated Current	I_{mp}	A	10.72	10.80	10.87	10.92
Fuse rating		A	20	20	20	20
Max. System Voltage		V	1,000	1,000	1,000	1,000

TABLE 6: MODULE TEMPERATURE COEFFICIENT

Module	Peak power: δ (%/°C)	Voltage: B (%/°C)	Current: α (%/°C)	NOCT (°C)
MSExxxSX9W <i>(xxx=420-440, in step of 5W, xxx is standing for rated output power at STC)</i>	-0.359% / °C	-0.261% / °C	0.044% / °C	44.69 °C
MSExxxSX9Z <i>(xxx=410-430, in step of 5W, xxx is standing for rated output power at STC)</i>	-0.361% / °C	-0.262% / °C	0.039% / °C	44.43 °C
MSExxxSX9R <i>(xxx=375-395, in step of 5W, xxx is standing for rated output power at STC)</i>	-0.361% / °C	-0.262% / °C	0.039% / °C	44.43 °C
MSExxxSX9T <i>(xxx=340-360, in step of 5W, xxx is standing for rated output power at STC)</i>	-0.361% / °C	-0.262% / °C	0.039% / °C	44.43 °C
MSExxxSX9K <i>(xxx=350-365, in step of 5W, xxx is standing for rated output power at STC)</i>	-0.361% / °C	-0.262% / °C	0.049% / °C	45.86 °C

9.0 MECHANICAL INSTALLATION

Mission Solar PV modules are considered to be in compliance with UL 61730 only when mounted in the manner specified by the mounting options below. Per UL standards, the maximum number of modules connected in series/parallel with correction factor of 1.56 as specified in the NEC is as follows:

- 19/1** for 60-cell module with maximum system voltage of 1000V
- 24/1** for 72-cell module with maximum system voltage of 1500V

- Please refer to your local Authority Having Jurisdiction (AHJ) as well as best installation practices for the maximum number of modules that can be installed in series and in parallel for your specific installation project site and application.
- For proper guidelines on tilt or elevation angle for your installation, please refer to the standard PV installation guide from a reputable installer or systems integrator.

MISSION SOLAR ENERGY LLC

ELECTRONIC versions are uncontrolled except when accessed directly from document control directory. Printed copies are uncontrolled unless verified against online document.

COPYRIGHT 2020 MISSION SOLAR ENERGY LLC, ALL RIGHTS RESERVED

- Always follow the instructions and safety precautions from the installation guide that came with the support frame to be used.
- Drilling holes on the module's frame and glass parts is not recommended as it will void the warranty.
- If additional wind or snow loads are anticipated for this installation, the support module mounting structure must be made of durable corrosion-resistant and UV-resistant material.
- Modules should not be installed near any other equipment.
- Ensure that the module is laid evenly between the two rails and sits perpendicular on the railing. If the module is not perpendicular, slightly adjust the clamp positions to get the proper alignment.
- Modules must be secured to the mounting structure using all four mounting points for normal installation.

9.1 GROUND MOUNT

Select a mounting system with enough height to prevent the lowest edge of the module from being covered with snow during winter in areas that experience heavy snowfalls. In addition, ensure that the lowest portion of the module is placed high enough so that it does not get covered in debris from plants or trees or damaged by sand and stone driven by wind.

9.2 ROOF MOUNT

When installing module on a roof or building, ensure that it is securely fastened and cannot fall as a result of wind or snow loads. Provide adequate ventilation under the module for cooling, 10cm minimum air space between the module and the mounting surface. The slope should be less than 5 in/ft. in order to maintain the certified fire class rating. When installing module on a roof, ensure that the roof construction is suitable. In addition, any roof penetration required to mount the module must be properly sealed to prevent leaks. In some cases, a special support frame may be necessary.



The roof installation of solar modules may affect the fireproofing of the house construction. The fire rating of this module is valid only when mounted in the manner specified in the mechanical mounting instructions. The modules have PV Type 1 of fire rating in accordance with the UL 61730. Installing a module during strong winds may cause accidents.

9.3 POLE MOUNT

When installing module on a pole, choose a pole and module mounting structure that will withstand anticipated winds and

snow loads for the area.

9.4 MOUNTING OPTIONS

- 9.6.1 Bolt method – Modules are secured to the support structure using an M7 x 16 mm (or ¼" x ¾") bolt and nut with flat washer and spring washer. Hardware is used on all four of the mounting holes on the long side frame, two on each side. Bolt shall be torqued to 16±2 N-m.
- 9.6.2 Clamp method - The capture area of the clamps should be a minimum 9.2 mm x 38 mm. Clamps are used in combination with a flat washer, locking washer, 1/4" nut and bolt that shall be torqued to 16±2 N-m. Four clamps are secured on the long side frame. The clamp placement locations are measured from the middle of the clamp to the short side frame:

TABLE 7: DESIGN LOAD AS SPECIFIED BY UL61730

INSTALLATION TYPE	MODULE	*MOUNTING DISTANCE [D]	FRONT OF MODULE DESIGN LOAD	BACK OF MODULE DESIGN LOAD
Bolt method	SX9W / SX9Z	546mm	3600 Pa	1600 Pa
	SX9R	506mm	3600 Pa	1600 Pa
	SX9T / SX9K	470mm	3600 Pa	1600 Pa
Clamp method	SX9W / SX9Z	469mm < D ≤ 546mm	3600 Pa	1600 Pa
		469mm	3600 Pa	2400 Pa
	SX9R	429mm < D ≤ 506mm	3600 Pa	1600 Pa
		429mm	3600 Pa	2400 Pa
	SX9T/SX9K	393mm < D ≤ 470mm	3600 Pa	1600 Pa
		393mm	3733 Pa	3754 Pa

*Mounting Distance [D] – distance between edge of module and middle of clamp (or mounting hole) location. This is assuming that modules are mounted on a certified mounting system.

FIGURE 1: BOLT METHOD

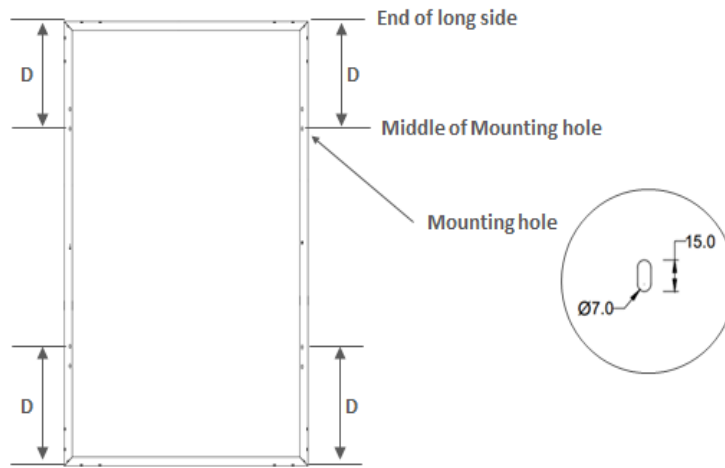
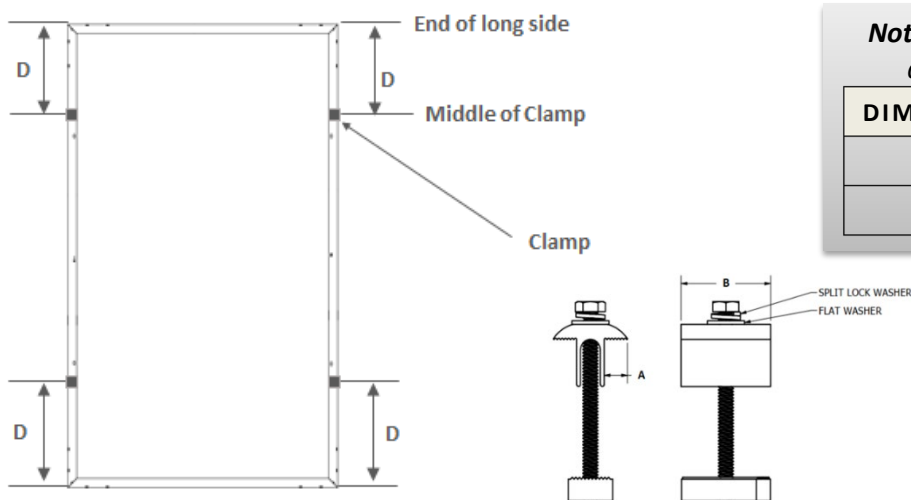

FIGURE 2: CLAMP METHOD



Note: Allowable clamp minimum dimensions are as follows:

DIMENSION	mm	in
A	9	.35
B	38	1.5

MISSION SOLAR ENERGY LLC

ELECTRONIC versions are uncontrolled except when accessed directly from document control directory. Printed copies are uncontrolled unless verified against online document.
 COPYRIGHT 2020 MISSION SOLAR ENERGY LLC, ALL RIGHTS RESERVED

- The recommended standoff height is 150 mm. If other mounting means are employed this may affect the UL Listing or the fire class ratings.
- Minimum slope of 5 in/ft for installation over a roof is required to maintain the fire class ratings.
- The PV modules are designed for a maximum altitude of 2000m.
- Artificially concentrated sunlight should not be directed on the module.
- Rated electrical characteristics are within 10 percent of measured values at Standard Test Conditions of: 1000 W/m², 25°C cell temperature and solar spectral irradiance as per IEC 60904-3
- Under normal conditions, a photovoltaic module may experience conditions that produce more current and/or voltage than reported at Standard Test Conditions. Accordingly, the values of I_{sc} should be multiplied by a factor of 1.25 and V_{oc} by a factor of up to 1.25 when determining component voltage ratings, conductor capacities, fuse sizes and size of controls connected to the module output.
- Refer to Section 690-8 of the National Electric Code for an additional multiplying factor of 1.25 which may be applicable.

MSE PERC 72

1) SX9W / SX9Z SERIES

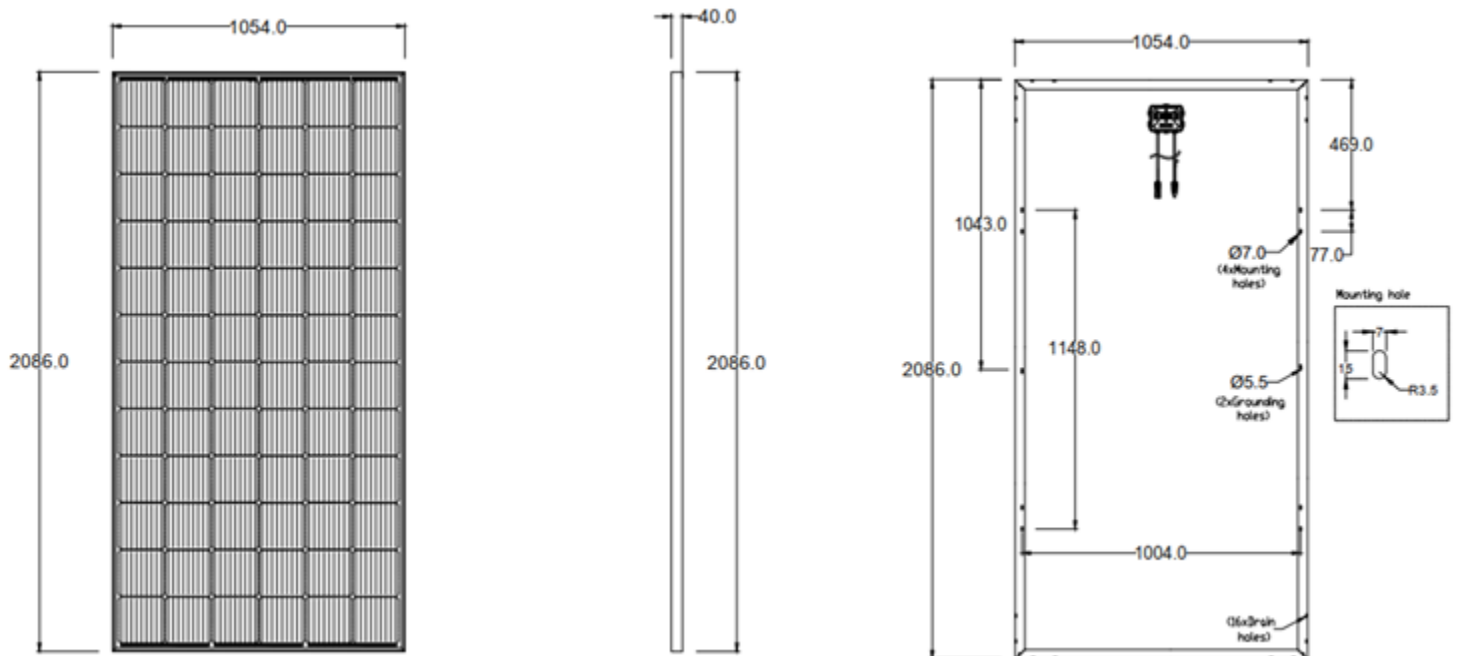

MISSION SOLAR ENERGY LLC

ELECTRONIC versions are uncontrolled except when accessed directly from document control directory. Printed copies are uncontrolled unless verified against online document.

COPYRIGHT 2020 MISSION SOLAR ENERGY LLC, ALL RIGHTS RESERVED

MSE PERC 66

2) SX9R SERIES

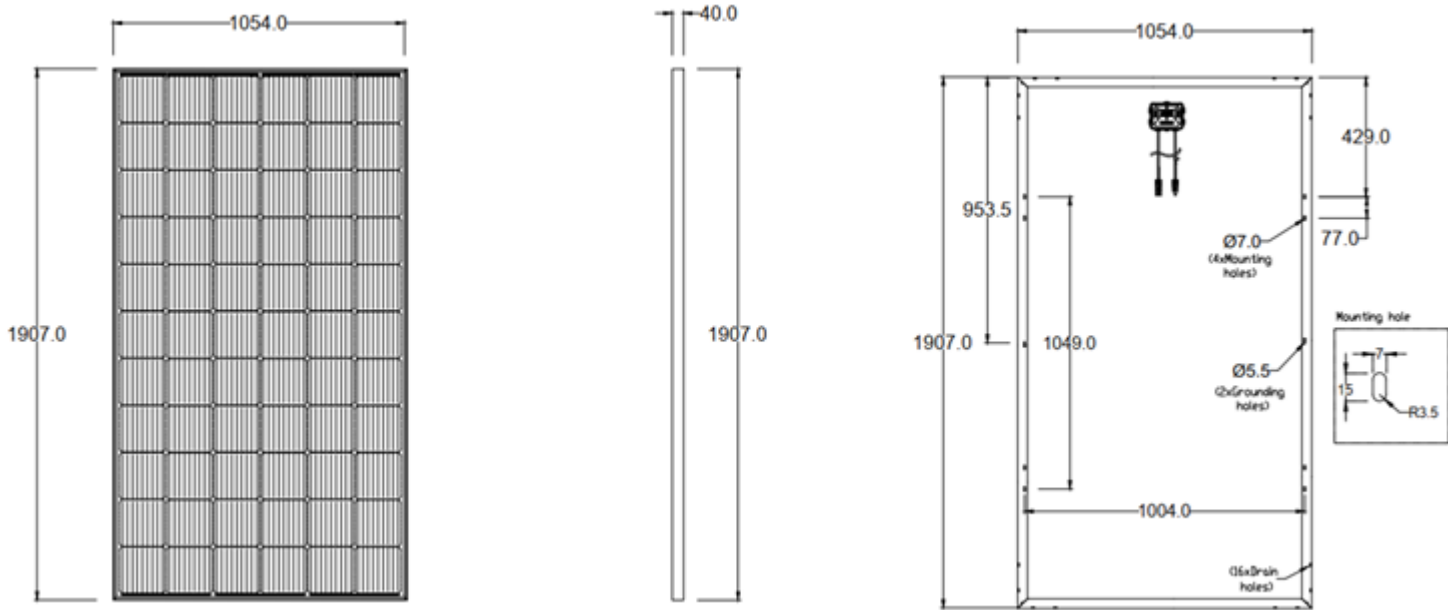

MSE PERC 60

3) SX9T/SX9K SERIES

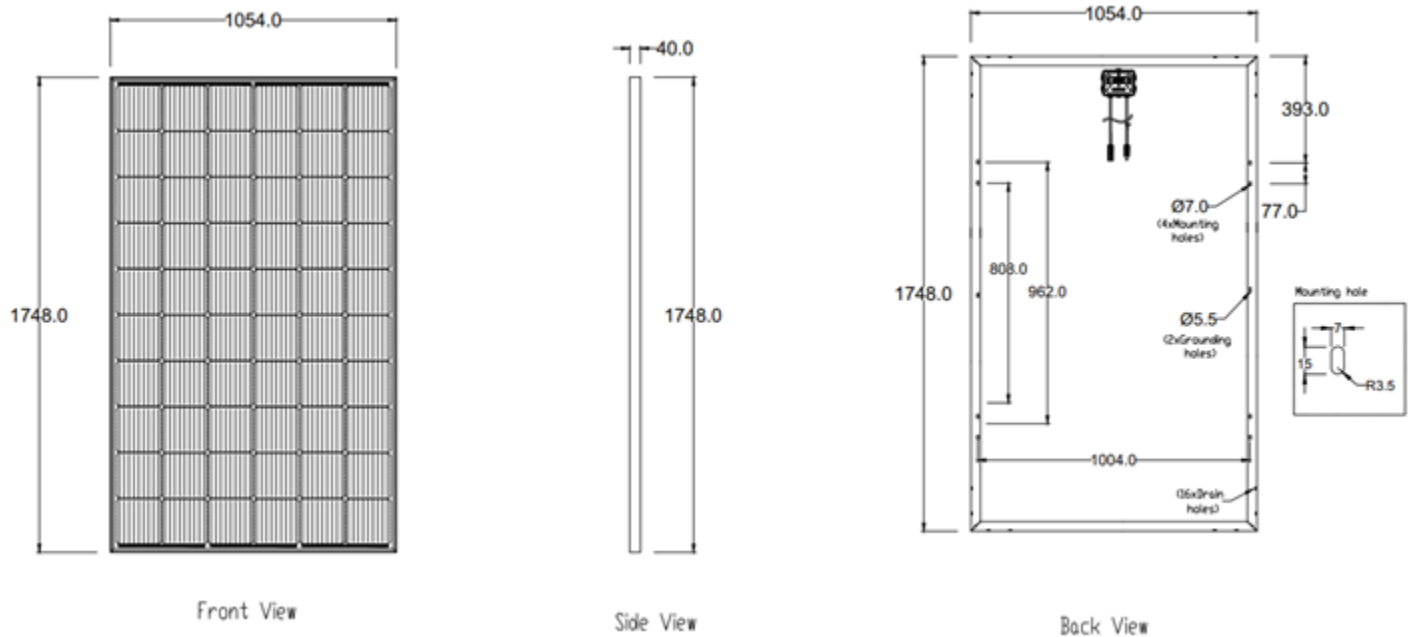

10.0 GROUNDING INSTRUCTIONS

A module with exposed conductive parts is considered to be in compliance with UL 61730 only when it is electrically grounded in accordance with the instructions presented below and the requirements of the National Electric Code. To

MISSION SOLAR ENERGY LLC

ELECTRONIC versions are uncontrolled except when accessed directly from document control directory. Printed copies are uncontrolled unless verified against online document.

COPYRIGHT 2020 MISSION SOLAR ENERGY LLC, ALL RIGHTS RESERVED

reduce the possibility of electrical shock, ground the frame of the module or array before wiring the circuit using a grounding method that meets NEC requirements for grounding solar electrical systems. In order to install on anodized aluminum frames, Mission Solar Energy modules shall be grounded using grounding hardware that has been certified to meet requirements for grounding systems in UL467, UL61730 or UL1741, which Mission Solar Energy recommends one of the following methods of grounding the module frame. The attachment must be made in conformance with the grounding device manufacturer’s instructions and be used with a racking system in compliance with UL Outline (Standard) 2703 where this module has been evaluated with that racking system.

10.1 WEEB-UIR

The WEEB washer family of products can be used to bond anodized aluminum, galvanized steel, steel and other electrically conductive metal structures. All installations shall be in accordance with NEC requirements in the USA and with CSA C22.1 in Canada. The WEEB washers are for use with modules that have a maximum fuse rating of less than 25A. Use WEEB-UIR to bond solar modules to module mounting purlin and torque fasteners to 7 ft-lb / 9.5 N-m using Penetrox-A on threads.

The following UL Recognized Bonding Washer, manufactured by BURNDY LLC (E351343), should be used to provide a reliable grounding connection to the module frame.

MODULE	GROUNDING DEVICE		
	Manufacturer	Type	Torque rating
All	BURNDY LLC	WEEB-UIR grounding washer)	9.5 Nm

The BURNDY grounding washer should be used in combination with a flat washer and M5 size nut/bolt to bond the module frame to the mounting rails/support (see figure 3).

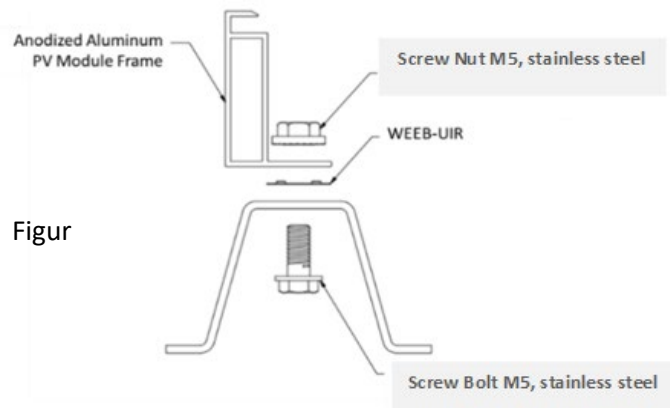

Figur

Grounding should be achieved through securement to the array frame. The array frame shall be grounded in accordance with NEC Article 250, and CSA C22.1, Safety Standard for Electrical Installations, Canadian Electrical Code, Part 1, for cUL listed modules

11.0 ELECTRICAL INSTALLATION

11.1 LOCAL / NATIONAL CODE AND LOCAL REGULATION

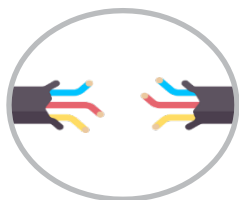

To carry out installation, local regulations that may apply should be taken into account such as NEC (USA) or Canadian Electrical Code (Canada). Wiring should be performed by a qualified and licensed professional. Wiring should be protected to help ensure personal safety and to prevent damage. All modules connected in series should be of same model number and/or same type. Do not connect modules in parallel without using a combiner box or equivalent.

Under normal conditions, a photovoltaic module is likely to experience conditions that produce current and/or voltage other than reported at Standard Test Conditions. The requirements of the National Electric Code (NEC) in Article 690 shall be followed to address these increased outputs. In installations not under the requirements of the NEC, the values of I_{sc} and V_{oc} marked on this module should be multiplied by a factor of 1.25 when determining component voltage ratings, conductor capacities, over current device ratings and the size of controls connected to the PV output.

11.2 WIRING

Mission Solar PV modules come with a factory assembled junction box. Do not open the junction box in any case. Wiring must be done in accordance with local/national code and regulations; wear protective gloves and shoes to avoid electric shock. Address the following recommendations:

- The modules combined in parallel will produce a specific current output. Each series string or module is required to be fused. Table 1 describes the maximum fuse size allowed.
- Do not connect the modules if the connectors are wet.
- Be sure to put the cables away from sharp edges.
- If you need additional cables you must use exclusively solar cable of 12AWG/4mm² minimum cross-sections, with ability to work in a temperature range of at least -40°C and 90°C.
- Install the modules so that water from rain or condensation cannot penetrate inside the cable conduits.
- Fix cables to the structure so that the connectors are protected from water ingress. Cables should be held by UV resistant clamps or ties.
- To minimize possible effects of lightning induced voltages, the surface of all conductive loops must be as small as possible.
- Check that the wiring is correct before starting the installation by verifying that the open voltage is within expected values.
- Protect cables that could suffer mechanical damage.
- Avoid direct sunlight on cables.
- Maximum series fuse rating 20A.
- Details for wiring in accordance with the NEC, and that the grounding method of the frame of arrays shall comply with the NEC, Article 250.
- Installation shall be in accordance with CSA C22.1, Safety Standard for Electrical Installations, Canadian Electrical Code and Part 1.
- Modules may be connected in series (voltage additive) and/or in parallel (current additive) to produce the appropriate electrical output. When connecting modules in parallel, each module (or series string of modules so connected) shall be connected according to the maximum series fuse as specified.
- Recommended series connection of module open circuit voltage should not exceed 80% limits range of the system voltage and the fuse should be connected at the end of each array.
- The installation instructions specify that grounding is achieved through securement to the array frame. The array frame must be grounded in accordance with NEC Article 250.
- Mission Solar modules are equipped with factory-installed wires and connectors. These modules have been designed to be easily connected in series. Each module has two single-conductor wires, one positive and one negative that are pre-wired inside the junction box.
- The connectors at the opposite end of these wires allow easy series connection of adjacent modules by firmly inserting the male connector of a module into the female connector of an adjacent module until the connector is fully seated.
- A separate return wire or wires are required to run the positive and negative terminations of the series string of modules to load. Male and female connectors pre-attached to wires could be used at the string terminations for return wire connections or for source circuit box terminations.

11.3 CONNECTORS

- Keep connectors dry and clean. Ensure that connector caps are hand-tight before connecting the modules.
- Do not attempt to make an electrical connection with wet, soiled, or otherwise faulty connectors.
- Avoid sunlight exposure and water immersion of the connectors. Avoid allowing connectors to rest on the ground.
- Ensure cable connectors are UL and Canadian code complaint.
- Faulty connections can result in arcs and electrical shock.
- Check that all electrical connections are securely fastened.
- Make sure that all locking connectors are fully engaged and locked.

MANUFACTURER	CONNECTOR MODEL NAME	ALLOWABLE MATING CONNECTOR MODEL NAME
Staubli Electrical Connectors AG www.staubli.com	PV-KBT4/6II-UR	PV-KST4/6II-UR
	PV-KBT4-EVO 2/6II-UR	PV-KST4-EVO 2/6II-UR
RENHE SOLAR www.renhesolar.com	05-8	05-8



11.4 DIODES

- The junction boxes used with Mission Solar Energy modules contain bypass diodes wired in parallel with the PV cell strings.
- In the case of partial shading, the diodes bypass the current generated by the non-shaded cells, thereby limiting modules heating and performance losses. Bypass diodes are not over-current protection devices.
- Bypass diodes divert current from the cell strings in the event of partial shading. In the event of a known or suspected diode failure, installers or maintenance providers should contact Mission Solar Energy.
- Never attempt to open the junction box.

12.0 MAINTENANCE

12.1 VISUAL INSPECTION

Mission Solar Energy recommends that PV systems be periodically inspected by the installer or other qualified personnel. The purpose of the PV system inspection is to ensure that all system components are functioning properly. At a minimum, this inspection should confirm the following:

- All cables and connector attachments are undamaged and properly secured.
- No sharp objects are in contact with the PV module surfaces.
- PV modules are not shaded by unwanted obstacles and/or foreign material.
- Mounting and grounding components are tightly secured with no corrosion.
- Defects should be addressed immediately.

12.2 CLEANING

- The dust accumulated on the front transparent substrate may reduce the power output, and may even cause regional hot-spot effect.
- It's usually not dangerous for the accumulated dust to reduce the sunshine because the light intensity is still homogeneous and power reduction is not usually obvious.
- When modules are installed, avoid environmental influence factors that cast shadows and cover part or all of the modules. This includes other modules, system support, bird drops, dust, and so on. This debris may distinctly reduce the power output.
- The cleaning frequency depends on the accumulation frequency and can vary from 6 months to 2 years. Do not use alkaline, abrasive, alkali or acid materials, detergents, or cleaning solutions to clean the module.
- It is recommended to wipe the glass surface with a wet sponge or soft cloth. Please do not clean the glass with a cleaning agent which contains acid or alkali.

www.missionsolar.com
Mission Solar Energy LLC

8303 S. New Braunfels Ave.
 San Antonio, Texas 78235
 info@missionsolar.com
 210-531-8600

13.0 REVISION HISTORY

REV	ORIGINATOR/DC INITIALS	DOCUMENT CONTROL	DESCRIPTION OF & REASON FOR CHANGE(S)	RELEASE DATE
0	JUNMO (JOHN) SEO	Kathleen Rodriguez	Initial release	09/09/2022

MISSION SOLAR ENERGY LLC

ELECTRONIC versions are uncontrolled except when accessed directly from document control directory. Printed copies are uncontrolled unless verified against online document.

COPYRIGHT 2020 MISSION SOLAR ENERGY LLC, ALL RIGHTS RESERVED