



# The Kid Solar Charge Controller Instruction Manual



## Features

- MPPT charge controller gives maximum yield for solar
- Standard model can wall or flush mount
- Marine model includes mounting bracket
- Backlit LCD display
- Works as a load controller / Charge controller
- Menu driven system control
- Can be input paralleled for a true 60 Amp single controller
- Conformal coated circuit board for harsh environments

UL 1741 ISSUE:2010/01/28 ED:2 INVERTERS, CONVERTERS,  
CONTROLLERS AND INTERCONNECTION SYSTEM EQUIPMENT  
FOR USE WITH DISTRIBUTED ENERGY RESOURCES  
CSA C22.2#107.1 ISSUED: 2001/09/01 ED: 3 (R2011) GENERAL  
USE POWER SUPPLIES  
UL 458 ISSUED:2006/04/19 ED:5 REV:2010/03/18  
UL STANDARD FOR SAFETY POWER  
CONVERTERS/INVERTERS AND POWER  
CONVERTER/INVERTER SYSTEMS FOR LAND  
VEHICLES AND MARINE CRAFTS  
CSA C22.2#107.2 ISSUE:2001/11/01 ED: 2  
ATTERY CHARGERS GENERAL INSTRUCTION  
NO. 1: 2003/06/01 ; GENERAL  
INSTRUCTION NO. 2: 2008/12/01 - (R2011)



Intertek  
3084883

This version of the Kid is for use **only** with solar installations.

MidNite Solar  
17722 - 67th Ave NE  
Arlington, Wa 98223  
www.midnitesolar.com



# The Kid Solar Charge Controller Instructions

## IMPORTANT SAFETY INSTRUCTIONS

**SAVE THESE INSTRUCTIONS** - THESE INSTRUCTIONS CONTAIN IMPORTANT SAFETY AND OPERATING INSTRUCTIONS FOR THE KID CHARGE CONTROLLER MODEL NUMBERS MNKID-B, MNKID-W, MNKID-M-B, MNKID-M-W.

If you do not fully understand any of the concepts, terminology, or hazards outlined in these instructions, please refer installation to a qualified dealer, electrician or installer. These instructions are not meant to be a complete explanation of a renewable energy system. All installations must comply with national and local electrical codes. Professional installation is recommended.

### GENERAL PRECAUTIONS:

**WORKING WITH OR IN THE VICINITY OF A LEAD ACID BATTERY, SEALED OR VENTED IS DANGEROUS. VENTED BATTERIES GENERATE EXPLOSIVE GASES DURING NORMAL OPERATION. FOR THIS REASON, IT IS VERY IMPORTANT THAT BEFORE SERVICING EQUIPMENT IN THE VICINITY OF LEAD-ACID BATTERIES YOU REVIEW AND FOLLOW THESE INSTRUCTIONS CAREFULLY.**

If service or repair should become necessary, contact MidNite Solar Inc. Improper servicing may result in a risk of shock, fire or explosion. To reduce these risks, disconnect all wiring before attempting any maintenance or cleaning. Turning off the inverter will not reduce these risks. Solar modules produce power when exposed to light. When it is not possible to disconnect the power coming from the Photovoltaics by an external means such as a combiner, cover the modules with an opaque material before servicing any connected equipment.

Do Not expose to rain or snow. NEVER attempt to charge a frozen battery. Do not smoke around batteries.

When it is necessary to remove a battery, make sure that the battery bank disconnect breaker is in the off position and that the PV breakers, grid breakers and any other sources of power to the inverter are in the off position. Then **remove the negative terminal from the battery first.**

To reduce risk of battery explosion follow these instructions and those published by the battery manufacturer as well as the manufacturer of any additional equipment used in the vicinity of the batteries.

Avoid producing sparks in the vicinity of the batteries when using vented batteries. Provide ventilation to clear the area of explosive gases. Sealed AGM and Gel batteries do not under normal conditions create explosive gases. Refer to the battery manufacturer's documentation. Be especially cautious when using metal tools. Dropping a metal tool onto batteries can short circuit them. The resulting spark can lead to personal injury or damage to the equipment. Provide ventilation to outdoors from the battery compartment when installing vented batteries such as golf cart T-105 batteries. The addition of a spill tray is also a good idea.

Clean all battery terminals. Very high currents are drawn from the batteries; even a small amount of electrical resistance can result in overheating, poor performance, premature failure or even fire.

Have plenty of fresh water and soap nearby in case battery acid contacts skin, clothing or eyes. Wear complete eye and clothing protection. Always avoid touching eyes while working near batteries. If battery acid or battery terminal corrosion contacts skin or clothing, wash immediately with soap and water. If acid enters the eyes, immediately flood with cool running water for at least 15 minutes and get medical attention immediately. Baking soda neutralizes battery acid electrolyte. Keep a supply near the batteries

Do not work alone. Someone should be in the range of your voice or close enough to come to your aid when you work with or near electrical equipment. Remove rings, bracelets, necklaces, watches etc. when working with batteries, photovoltaic modules or other electrical equipment. Power from an illuminated photovoltaic array makes a very effective arc welder with dire consequences if one of the welded pieces is on your person.

To reduce the risk of injury, connect only deep cycle lead acid type rechargeable batteries. Other types of batteries may leak or burst, causing personal injury or damage.

Wiring methods used shall be in accordance with the Canadian Electrical Code, Part I.

Wiring must be done in accordance with the National Electrical Code Article 690 ANSI/NFPA 70. Use Class 1 wiring methods for field wiring connections to terminals of a Class 2 circuit. Use only 14-10 gauge AWM wire. Select the wire gauge used based on the protection provided by the circuit breakers/fuses. Overcurrent protection must be installed as part of the system installation. Refer to the wiring diagrams provided in this manual for breaker/fuse/GFDI sizes and model numbers.

**WARNING:** This unit is not provided with a GFDI device. This inverter or charge controller must be used with an external GFDI device as required by the Article 690 of the National Electrical Code for the installation location.

Use of attachments or accessories not approved by MidNite Solar could result in damage or injury.

Before making any connections verify that the circuit breakers are in the off position including the inverter breaker. Double check all wiring before applying power.



## INSTRUCTIONS DE SÉCURITÉ IMPORTANTES

**CONSERVER CES INSTRUCTIONS** - CES INSTRUCTIONS CONTIENNENT DES INFORMATIONS IMPORTANTES POUR UTILISER LE MIDNITE SOLAR THE KID CHARGE CONTROLLER (RÉGULATEUR DE CHARGE) MODEL NUMBERS MNKID-B, MNKID-W, MNKID-M-B, MNKID-M-W EN TOUTE SÉCURITÉ.

Avant l'utilisez cet appareil lis et comprends toutes les instructions et avertissements.

Si vous ne comprenez pas l'une des concepts ou des instructions contenu dans cette manuel consulter un agent spécialisé.

Si des réparations sont nécessaires contactez MidNite Solar pour plus des informations. Danger de choc électrique et de risque de brulure. Rien à dépanner à l'intérieure du cette appareil. Ne pas ouvrir le couver. Pour toute réparation ou service d'entretien, consulter un agent spécialisé. Il y'a peut-être plusieurs sources d'alimentation dans cette system. Débrancher toutes les interrupteurs avant toute d'entretien où nettoyage.

Ne travaillez pas seul. Quelqu'un devrait toujours être à proximité pour aider en cas d'une situation d'urgence.

Retirer bagues, bracelets, colliers, montres, et quelles choses comme ça. Il y'a risque des blessures graves s'il y'a un court-circuit. Cela pourrait ruiner votre journée entière.

Cette appareil n'avoir pas un détecteur des fautes de terre. C'est nécessaire de emploi la protection contre des fautes de terre a l'extérieure de cette appareil en conformité avec le National Electrical Code.

Les méthodes de câblage utilisés doivent être conformes au Code canadien de l'électricité, Partie I.

Le câblage doit être fait en conformité avec le National Electrical Code Article 690 ANSI / NFPA 70. Utiliser des méthodes de câblage de catégorie 1 pour les connexions de câblage sur .des terminaux d'un circuit de classe 2. Utilisez uniquement des fils de AWM de calibre 14-1/0. Sélectionnez le type de câble utilisé sur la base de la protection prévue par les disjoncteurs / fusibles.



## Table of Contents

Warnings.....	2
The Kid Dimensions.....	6
Mounting The Kid.....	6
Stickers.....	8
Wiring.....	13
Aux Input / Output.....	16
MNBTS Battery Temperature Sensor.....	18
Stacking The Kid.....	18
Set-Up and Use.....	20
Status Screens.....	24
The Kid Keypad.....	25
Firmware Update.....	38
Automatic Generator Starting - AGS.....	40
Wiring Diagrams.....	44
HyperVOC.....	48
Power Graph.....	49
Accessories.....	49
Whiz Bang Jr. Current Monitoring.....	52
Warranty Information.....	54
Specifications.....	55
Ratings / Fuses.....	56
The Kid Menu Map.....	57
Glossary.....	59
Wall Mount Template.....	60

### Symbols used in this manual



Ground Symbol  
Indicates an earth ground connection.



# The Kid Solar Charge Controller Instructions

## Included Hardware kit

The parts included in the hardware kit provide great flexibility for installing The Kid in many different locations.

9-614-1 90° 1/2" snap-in Conduit adapter (2)\*



There are straight and right angle fittings for flex conduit as well as a strain relief for power wires and a split grommet for data wires.

9-642-1 Heyco M3200 Conduit Adapter  
6-092-1 Nut for M3200 Conduit Adapter Nut



9-614-2 Straight conduit adapter (2)\*



6-022-1 Split grommet



9-154-1 Micro Shunt (2)  
See page 19



9-557-2 Spare Fuse/Jumper (2)



5-179-2  
USB Hole Plug



9-595-1 Ground lug  
See page 17



6-002-1 Kepnut for ground lug

\* Marine hardware kit Only.



# The Kid Solar Charge Controller Instructions

## Mounting the KID:

There are three methods of mounting available for the KID:

### 1. In wall mounting.

This is very useful for RV's, some boats and cabins or just about anywhere you want a built in look. You will need to insure that the wall is not so thick as to obstruct the wiring that enters through the bottom surface of the KID. The conduit wire holes in the bottom of the casting are 0.28" (7mm) away from the back mounting flange. So if your wall is more than 0.25" (6.35mm) thick, this may interfere with accessing the wiring behind the wall. The conduit nut or adapter also takes away from this narrow wall allowance. You may be able to remove some material from the back surface of the wall to increase clearance.

Mounting holes are designed for #10 (5mm) screws.

The hole cut into the wall must be very accurate. A template is provided at the end of this manual. The casting on the KID is 8.65" (219mm) x 4.54" (115mm) with a .400 (10mm) radii on each corner. Mounting holes are designed for a #10 (5mm) screw. The center to center dimensions are 8.763" (222mm) x 4.5" (114mm) The KID has a depth of 1.45" (37mm) from the mounting flange to the back surface.

A template is provided at the back of this manual.



The Kid mounted in the wall

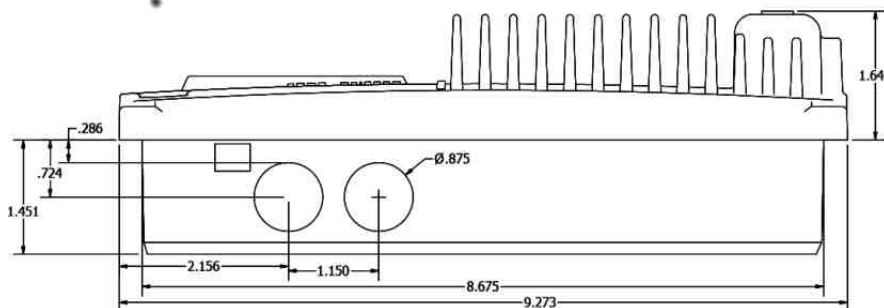



# The Kid Solar Charge Controller Instructions

## 2. Surface mount.

The Kid can be mounted on a wall using the supplied wall mount adapter. As a minimum you will need to supply  $\frac{1}{2}$ " strain reliefs to secure the wires to the casting. Regular metal strain reliefs are available at any hardware or electrical store. Metal Romex strain reliefs are designed to clamp down on Romex shielded cable. You will most likely be using individual 10AWG conductors and therefore the outer sheath to protect the conductors will not be there. Be aware that excessive clamping pressure from the strain relief will bite through the wire insulation and short the conductors to the case. Not only can this cause fires, it is very hard to trouble shoot.



Locate and twist out the wire knockouts in the bottom section of the wall mount adapter.

Secure the plastic wall mount adapter to the wall using appropriate screws (not provided). Make sure the screws are adequate for the weight of the KID. The wall mount adapter is intended to use #10 (5mm) screws.



Make the wire connections to the terminal block inside the KID, replace the back plate and then assemble the KID to the wall mount adapter. Use the #10 x  $\frac{3}{4}$ " Plastite screws provided to secure the KID to the wall mount adapter. Black units get black stainless steel screws and white units get natural stainless steel screws.

**RIGHT:** The Kid surface mounted.





# The Kid Solar Charge Controller Instructions

## Sticker Identification

- Warning-ignition protected.
- Equipment grounding terminal.
- Connection sequence.
- Do not overtighten.
- Shipping serial number.
- Negatives Separate.
- Model Number.
- Caution Voltage Present.
- Aux Output Ratings.
- CE.
- Don't touch uninsulated.
- Charge battery types.
- Start up info.
- Cautions.
- Protect from rain.
- Arcs and sparks - Français.
- Arcs and sparks - English.
- Torque.
- Ground Symbol.
- Fuse type.
- C-Tick.
- Stored energy warning - English.
- Stored energy warning - Français.

White Sticker set shown.  
Also applies to black Sticker set .

**1** **CAUTION:** To reduce the risk of explosion, Do not install in machinery space or area in which ignition-protected equipment is required.  
**DANGER:** Pour réduire le risque d'explosion Ne pas installer dans local des machines ou de la région quel équipement protégé contre les incendies est nécessaire.

**2** **EQUIPMENT GROUNDING TERMINAL**

**3** **ATTENTION:** RISQUE DE CHOC ELECTRIQUE PAR L'ENERGIE RETENU DANS LE NE PAS OUVRIR LE COUVERCLE JUSQU'AU 4 - 1/2 MINUTES APRES DECONNECTER TOUTS SOURCES DE PUISSANCE.

**4** **DO NOT OVERTIGHTEN**

**5** **NEGATIVE IN AND OUT MUST BE ISOLATED - SEE MANUAL**

**6** **FOR MARINE AND CANADIAN APPLICATIONS CHARGE ONLY LEAD-ACID BATTERIES OTHER TYPES OF BATTERIES MAY BURST CAUSING PERSONAL INJURY AND DAMAGE. ATTENTION: UTILISER SEULS CHARGES UNISEMMENT LES ACCUSUMATEURS DU TYPE ACIDE PLUMB. NE PAS TOUCHER LES PARTIES NON ISOLEES DU CONNECTEUR DE SORTIE OU LES BORNES NON ISOLEES DE L'ACCUMULATEUR.**

**7** **ATTENTION:** RISQUE DE CHOC ELECTRIQUE PAR LES COUS EN PROXIMITE EN FAISANT LES CONNEXIONS DE PUISSANCE. RISK OF FIRE AND SHOCK. MAKE BATTERY CONNECTIONS FIRST, THEN PV AND SHOCK. THEN LOAD CONNECTIONS LAST.

**8** **CAUTION:** VOLTAGE MAY BE PRESENT AT THE PV INPUTS EVEN AFTER THEY ARE DISCONNECTED.  
**ATTENTION:** TENSION PEUVANT ETRE AUX ENTrees PV MEME APRES QU'ILS SONT DECONNECTES.

**9** **ATTENTION:** RISQUE DE CHOC ELECTRIQUE PAR L'ENERGIE RETENU DANS LE NE PAS OUVRIR LE COUVERCLE JUSQU'AU 4 - 1/2 MINUTES APRES DECONNECTER TOUTS SOURCES DE PUISSANCE.

**10** **CE**

**11** **CAUTION:** TO REDUCE THE RISK OF EXPLOSION, DO NOT INSTALL IN MACHINERY SPACE OR AREA IN WHICH IGNITION-PROTECTED EQUIPMENT IS REQUIRED.  
**DANGER:** POUR REDUIRE LE RISQUE D'EXPLOSION NE PAS INSTALLER DANS LOCAL DES MACHINES OU DE LA REGION QUEL EQUIPEMENT PROTEGE CONTRE LES INCENDIES EST NECESSAIRE.

**12** **ATTENTION:** RISQUE DE CHOC ELECTRIQUE PAR L'ENERGIE RETENU DANS LE NE PAS OUVRIR LE COUVERCLE JUSQU'AU 4 - 1/2 MINUTES APRES DECONNECTER TOUTS SOURCES DE PUISSANCE.

**13** **IMPORTANT! START-UP INFORMATION:** TO VERIFY BATTERY CONNECTIONS ARE CORRECT, CONNECT BATTERY POSITIVE AND NEGATIVE FIRST, THEN CONNECT ARRAY POSITIVE AND NEGATIVE. IF THE UNIT POWERS UP, THE BATTERY CONNECTIONS ARE CORRECT. DABOARD FAHRE LA CONNEXION DES ACCUS ET PUIS FAIRE LES CONNEXIONS DES PANNEAUX SOLAIRE. SILE L'UNIT COMMENCEZ A FONCTION, LES CONNEXIONS A LES ACCUS SONT CORRECTS ET ON POUVEZ UTILISER LA "LOAD" CIRCUIT PAR LA INSTALLATION DE LA FUSIBLE "LOAD".

**14** **ATTENTION:** RISQUE DE CHOC ELECTRIQUE PAR L'ENERGIE RETENU DANS LE NE PAS OUVRIR LE COUVERCLE JUSQU'AU 4 - 1/2 MINUTES APRES DECONNECTER TOUTS SOURCES DE PUISSANCE.

**15** **CAUTION:** TO REDUCE THE RISK OF ELECTRIC SHOCK DO NOT EXPOSE TO RAIN OR SPRAY NE PAS EXPOSER AUX INTempERES

**16** **CAUTION:** TO REDUCE THE RISK OF ELECTRIC SHOCK DO NOT EXPOSE TO RAIN OR SPRAY NE PAS EXPOSER AUX INTempERES

**17** **WARNING:** - This unit employs components that tend to produce arcs or sparks - To prevent fire or explosion, do not install in compartments containing batteries or flammable materials.  
**CAUTION:** - To prevent fire, do not cover or obstruct ventilation openings. Do not mount in zero-clearance compartment. Overheating may result.

**18** **CAUTION:** - Get appareil utiliser des composants qui ont tendance à produire des arcs ou d'étincelles matériaux inflammables ATTENTION - Pour éviter un incendie, ne pas couvrir ou obstruer les ouvertures de ventilation. Ne pas monter dans le compartiment sans dégagement. Une surchauffe peut entrainer

**19** **GROUND SYMBOL**

**20** **WARNING:** - For Continued Protection Against Risk Of Fire/Replace Only With Same Type And Ratings Of Fuse - 40 AMP ATC. See back for start-up sequence.  
**AVERTISSEMENT:** - Pour Maintenir La protection contre les risques d'incendie, remplacez uniquement par Même type et les qualifications De fusible ATC 40 AMP. Voir le dos pour plus de information à la séquence de commencement.

**21** **CAUTION:** TO REDUCE THE RISK OF ELECTRIC SHOCK DO NOT EXPOSE TO RAIN OR SPRAY NE PAS EXPOSER AUX INTempERES

**22** **WARNING:** - This unit employs components that tend to produce arcs or sparks - To prevent fire or explosion, do not install in compartments containing batteries or flammable materials.  
**CAUTION:** - To prevent fire, do not cover or obstruct ventilation openings. Do not mount in zero-clearance compartment. Overheating may result.

**23** **ATTENTION:** RISQUE DE CHOC ELECTRIQUE PAR L'ENERGIE RETENU DANS LE NE PAS OUVRIR LE COUVERCLE JUSQU'AU 4 - 1/2 MINUTES APRES DECONNECTER TOUTS SOURCES DE PUISSANCE.

**21** **CAUTION:** TO REDUCE THE RISK OF ELECTRIC SHOCK DO NOT EXPOSE TO RAIN OR SPRAY NE PAS EXPOSER AUX INTempERES

**22** **WARNING:** - This unit employs components that tend to produce arcs or sparks - To prevent fire or explosion, do not install in compartments containing batteries or flammable materials.  
**CAUTION:** - To prevent fire, do not cover or obstruct ventilation openings. Do not mount in zero-clearance compartment. Overheating may result.

**23** **ATTENTION:** RISQUE DE CHOC ELECTRIQUE PAR L'ENERGIE RETENU DANS LE NE PAS OUVRIR LE COUVERCLE JUSQU'AU 4 - 1/2 MINUTES APRES DECONNECTER TOUTS SOURCES DE PUISSANCE.

**10-249-2 REV B-6-16-14 DCA-)**

**20** **WARNING:** - For Continued Protection Against Risk Of Fire/Replace Only With Same Type And Ratings Of Fuse - 40 AMP ATC. See back for start-up sequence.  
**AVERTISSEMENT:** - Pour Maintenir La protection contre les risques d'incendie, remplacez uniquement par Même type et les qualifications De fusible ATC 40 AMP. Voir le dos pour plus de information à la séquence de commencement.

**21** **CAUTION:** TO REDUCE THE RISK OF ELECTRIC SHOCK DO NOT EXPOSE TO RAIN OR SPRAY NE PAS EXPOSER AUX INTempERES

**22** **WARNING:** - This unit employs components that tend to produce arcs or sparks - To prevent fire or explosion, do not install in compartments containing batteries or flammable materials.  
**CAUTION:** - To prevent fire, do not cover or obstruct ventilation openings. Do not mount in zero-clearance compartment. Overheating may result.

**23** **ATTENTION:** RISQUE DE CHOC ELECTRIQUE PAR L'ENERGIE RETENU DANS LE NE PAS OUVRIR LE COUVERCLE JUSQU'AU 4 - 1/2 MINUTES APRES DECONNECTER TOUTS SOURCES DE PUISSANCE.

8 | Page

10-268-1 REV E





# The Kid Solar Charge Controller Instructions

## Sticker Placement

Due to the large number of required warnings it is easy to begin to overlook them. Some of the warnings are actually quite important and good knowledge for the installer and user. All required labels are supplied. You will find a label identifier on the previous page. The placement guide below shows where each label goes. Please take the time to read and understand each label as you place it on the unit.

These warning labels are *Required* by the regulatory standards that The Kid has been tested to. Place the stickers where shown. Some Stickers will be applied at the factory. Some are internal and number 12 will be on the shipping box.

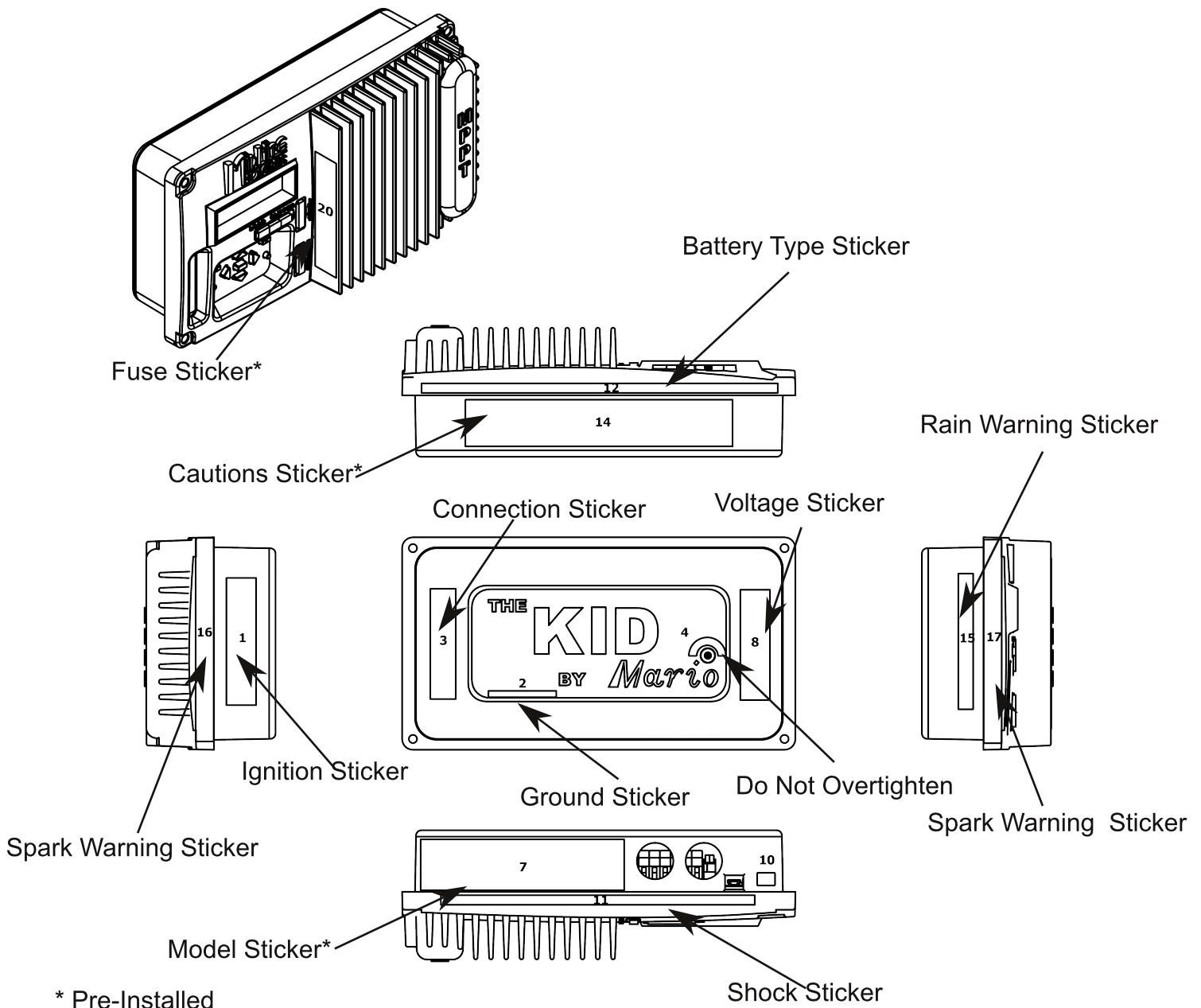



# The Kid Solar Charge Controller Instructions

## Additional Stickers:

In Canada CSA 22.2 No. 107.1-01 requires certain information to be visible while the unit is in operation.

To satisfy this requirement some additional stickers have been provided on the wall mount adapter. These stickers have the same information as those already on The Kid.

## Marine Unit 90° conduit adapters

When using both 90° conduit adapters side by side it is necessary to remove 1/8" from the side of each conduit adapter to allow them to fit so closely together.



**⚠ DANGER CAUTION**

**⚠ ATTENTION CAUTION**

ELECTRICAL SHOCK AND BURN HAZARD. SOLAR PANELS WILL CONTINUE TO PRODUCE VOLTAGE EVEN WHEN DISCONNECTED. ENSURE THAT PV MODULES ARE COVERED. TURN OFF PV ARRAY AND DISCONNECT THE BATTERIES PRIOR TO SERVICE. RISK OF ELECTRIC SHOCK. DO NOT REMOVE COVER. NO USER SERVICEABLE PARTS INSIDE. REFER SERVICING TO QUALIFIED SERVICE PERSONNEL. THIS UNIT IS ENERGIZED BY MORE THAN ONE SOURCE. DISCONNECT ALL SOURCES BEFORE SERVICE. DANGER DE CHOC ELECTRIQUE ET RISQUE DE BRULURE. LES PANNEAUX SOLAIRES CONTINUERONT DE PRODUIRE L'ELECTRICITE MEME S'ILS SONT DEBRANCHES. S'ASSURER QUE LES PANNEAUX SOLAIRES SONT COUVERTS PENDANT L'ENTRETIEN. POUR TOUTE ACTION D'ENTRETIEN, LA SORTIE DES PANNEAUX SOLAIRES ET LES ACCUS DOIVENT ETRE DECONNECTES. RIEN A DEBRANCHER A L'INTERIEUR. NE PAS OUVRIRE LE COUVER. POUR TOUTE REPARATION OU SERVICE D'ENTRETIEN, CONSULTER UN AGENT SPECIALISE. CETTE APPAREIL A PLUSIEURS SOURCE D'ALIMENTATION. DEBRANCHE TOUTE SOURCES D'ALIMENTATION AVANT SERVICE OU ENTRETIEN.

NOMINAL BAT VOLTAGES 12-48VDC  
 MAX PV CURRENT (OPERATING) 30A  
 MAX PV SHORT CIRCUIT CURRENT 30A  
 MAX BATTERY CHARGE VOLTAGE 64V  
 MAX OUTPUT FAULT CURRENT 30A  
 MAX CHARGE CURRENT 30A CONT.  
 NOMINAL OPERATING ENVIRONMENT:  
 25°C (50°C DE-RATED SEE MANUAL)

PV OPERATING VOLTAGE 12V-150VDC  
 MAX PV VOC, NON OPERATING 162V  
 LOAD / CLIPPER  
 MAX VOLTAGE 150VDC  
 MAX LOAD 30 AMPS  
 FOR MARINE USE  
 POUR UTILISATION MARINE  
 MIDNITE SOLAR, INC.  
 ARLINGTON, WA 98223 USA

**DANGER:** To reduce the risk of explosion Do not install in machinery space or area in which ignition-protected equipment is required.

**DANGER:** Pour réduire le risque d'explosion Ne pas installer dans local des machines ou de la région quel équipement protégé contre les incendies est nécessaire.

**CAUTION:** TO REDUCE THE RISK OF ELECTRIC SHOCK DO NOT EXPOSE TO RAIN OR SPRAY

**AVERTISSEMENT:** NE PAS EXPOSER AUX INTEMPÉRIES



# The Kid Solar Charge Controller Instructions



### 3. Marine mount.

The third way to mount the KID is with the Marine Mount Bracket.

**MNKID-M-BKT-W** (White) or **MNKID-M-BKT-B** (Black) Marine Mounting Brackets.

This bracket comes standard with Marine versions. There are two metal pieces that come with the Marine Mount Bracket. A collar that mounts to the KID and the Marine mounting bracket base. Mount the KID to the collar using four 8-32 screws and nuts provided. The kit is available in black or white.

If your installation is to have wiring go through the bracket, then first remove the knockout holes. Mount the bracket securely to a suitable surface Using #10 (5mm) screws.

The base may be mounted from under or above. Two thin rubber washers are provided that go between the collar and the bracket. They help keep the KID from slipping after tightening up the black knobs.

#### **Important!**

Mounting bracket may not be suitable for extreme vibration environments.

The Kid has an IP rating of 50 and should be protected from rain, snow or other moisture.



# The Kid Solar Charge Controller Instructions

## Optional rain Shield.

Required for approved marine applications.

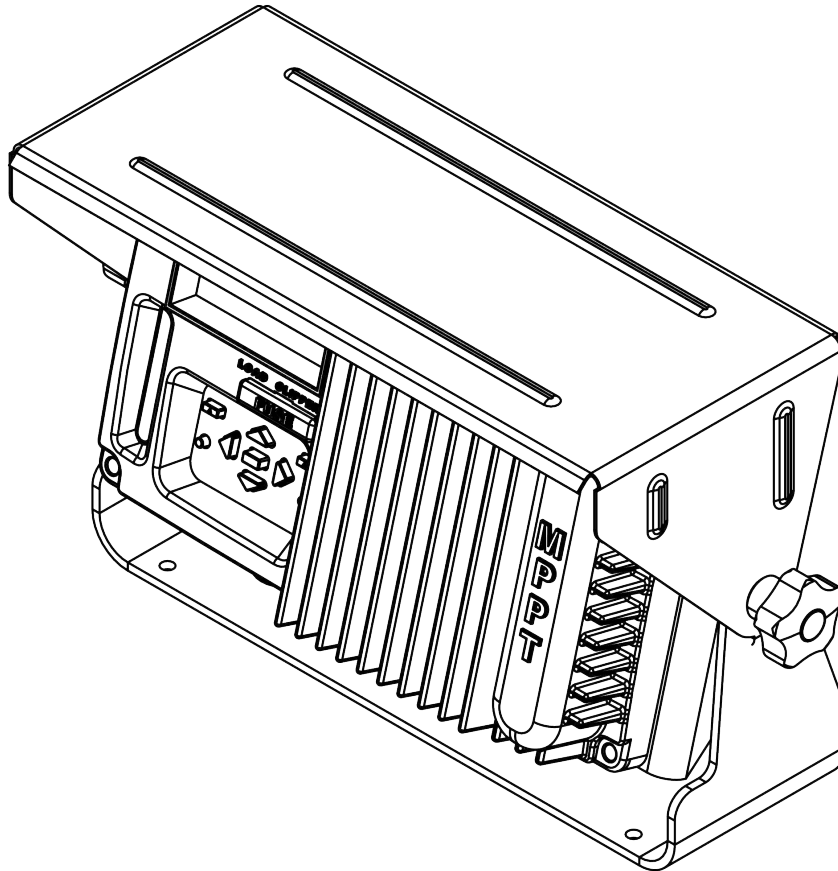

The Kid shown with the optional Rain/Drip Shield.

The rain/drip shield is required for code compliant marine applications. The addition of the rain/drip shield does not make the Kid weatherproof. Install the Kid where it will be protected from rain, spray, snow or other moisture.

The use of Loctite® Threadlocker 222 (Purple) is recommended to prevent the marine mount from loosening due to vibration.

The Kid should be rotated no more than 15° to maintain protection from the rain/drip shield.



# The Kid Solar Charge Controller Instructions

## The Kid Main Electrical Connections

The following pages contain wiring diagrams and system images.

### Remove the back cover.

Remove the screw on the middle right of the back cover and gently remove the back cover.

The connections for PV input, Load and Battery out are available on the terminal block shown below, located inside The Kid on the backside of the circuit board. Observe polarity on all connections.

**PV Input:** Connections from the solar panels go here.

**Load:** Connections to the controlled load (load control function).

**Battery Out:** Connections to the battery bank go here.

Torque all connections to 7-9 inch pounds (0.80 - 1.0 Nm).

**Input and output negatives *must* be isolated for proper operation.**

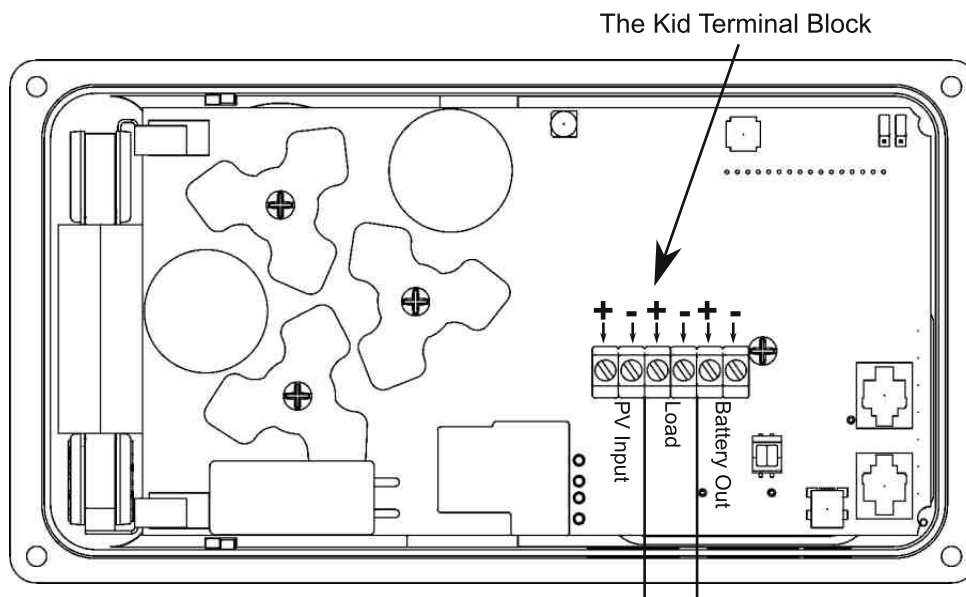

### Rear View of The Kid with the back cover removed.

Use 75°C Minimum rated copper conductors.

Utiliser uniquement avec conducteurs de cuivre nominale minimale de 75° C



# The Kid Solar Charge Controller Instructions

## Grounding Lug

Grounding points are provided inside and on the back of The Kid.  
This ground is necessary to satisfy the requirements of UL458 Marine and RV standard.

Drill a 7/32" hole approximately where shown. Make sure that you have room inside the unit for screwhead clearance.

Install the external ground lug as shown below with the hardware supplied.

Be sure to use the #10 lockwasher as shown. This is to cut through any paint overspray that might interfere with making a solid ground connection.

Verify the ground connection using a digital meter with the beep setting. There must be less than 0.1 Ohm of resistance between the ground lug and the back cover mounting screw.

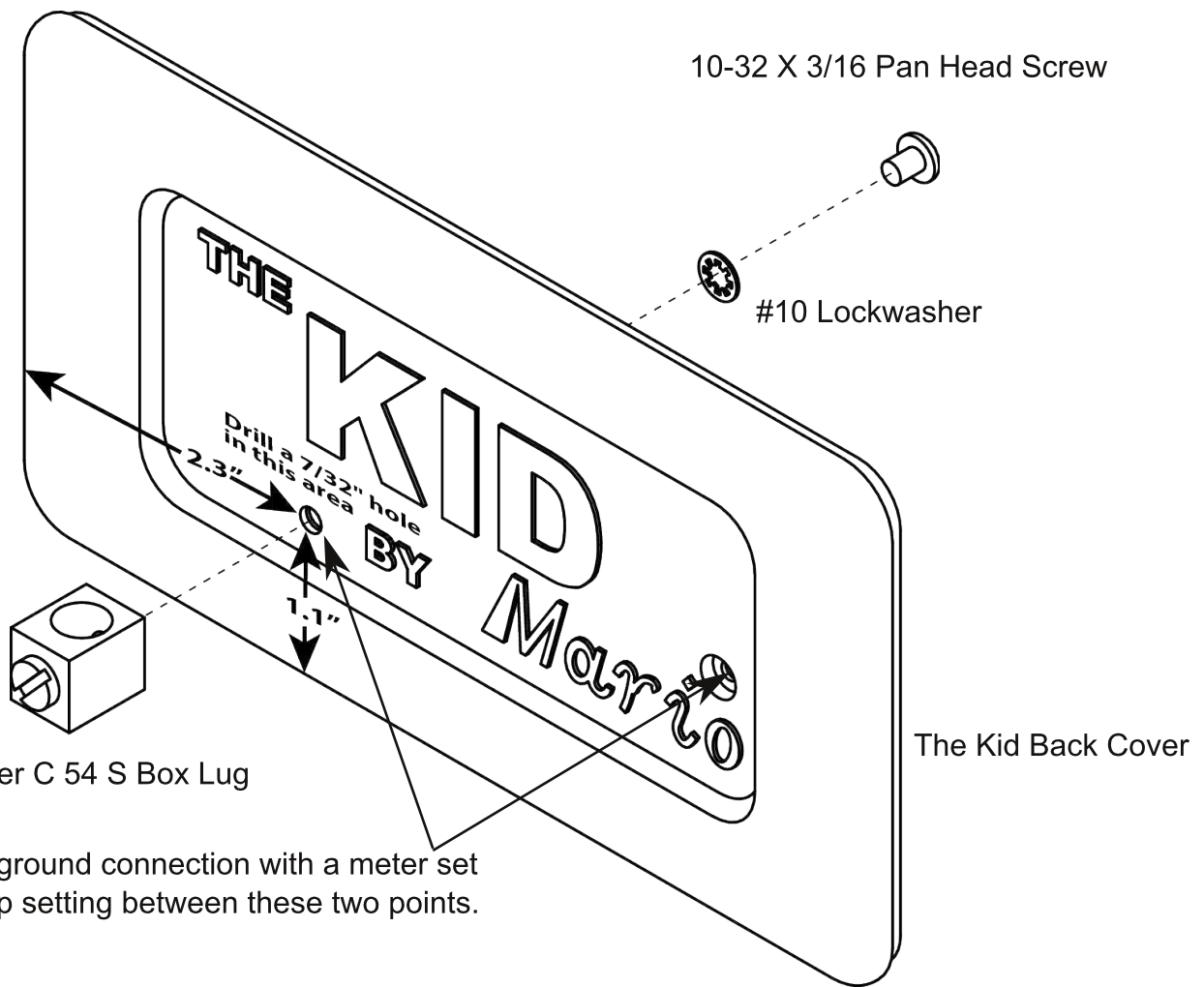

Verify the ground connection with a meter set to the beep setting between these two points.



Grounding Lug hardware supplied with The Kid



# The Kid Solar Charge Controller Instructions

## Wiring to the KID

Centered directly above the ½” conduit holes you will find the main 30 amp 6 position terminal block. This is where you will connect PV input, loads (if any) and the battery bank. The battery bank should use 10AWG wire (5.26mm<sup>2</sup>). On the included wiring diagrams you will notice an external 30 amp circuit breaker in series with the battery plus wire. This is very important and is a *requirement* to meet NEC guidelines for overcurrent and disconnect devices. The battery overcurrent device regardless whether it is a circuit breaker or fuse must be rated for the DC voltage rating of the battery bank with a minimum of 5000 Amp interrupt rating. Fuses incorporated into the KID are not to be used as these NEC required overcurrent devices. The internal KID fuses are for internal KID operation only. MidNite Solar manufactures numerous circuit breaker boxes for this use.

PV input overcurrent devices should follow the NEC guidelines of 1.56 times short circuit current. Therefore two 250 watt modules in series results in 8.87 amps of short circuit current (Isc) X 1.56 = 13.83 amps. The NEC allows 15 amps through most 14AWG wire, so in this case 14AWG wire is sufficient. Long distances (over 30 feet / 9 meters) may want to use larger wire to minimize voltage drop. Now let's take those same two solar panels and put them in parallel. This configuration will result in 17.7 Isc amps. Multiply this by 1.56 = 27.6 amps. 10AWG wire is rated for 30 amps, so you would need to switch to 10AWG wire for paralleled operation. The NEC requires a disconnect and overcurrent protection on the PV input. Overcurrent protection can be a fuse or circuit breaker. Thermal circuit breakers require the same 1.56 times Isc, but MidNite solar hydraulic/magnetic breakers require only 1.25 times Isc. All MidNite din rail and panel mount breakers are hydraulic/magnetic and are rated to hold 100% current. The use of a breaker is typical because you also get the required disconnect at the same time. MidNite Solar manufactures Baby, Big Baby and Quad boxes to help comply with these requirements.

The wiring diagrams included in these instructions also include another breaker in series with the PV input breaker. This additional device is a DC-GFP. (ground fault protector). The NEC mandates the use of DC-GFP's in all solar systems to help eliminate fires caused from faulty wiring. We find that the best use for these devices is to find wiring errors made during the initial installation. MidNite Solar manufactures the MNDC-GFP63 that fits in the Baby and Big Baby box along with a MNPV30 input breaker. The Big Baby can also hold the battery breaker as discussed above. So one Big Baby box, one MNDC-GFP63, and two MNEPV30 breakers fit the bill for all NEC required disconnects and overcurrent devices. This marine unit should be connected to a grounded, metal, permanent wiring system; or an equipment-grounding conductor should be run with circuit conductors and connected to equipment-grounding terminal or lead on unit. Connections to unit should comply with all local codes and ordinances.

Connect battery positive and negative first. Then connect array positive and negative. Then apply power by turning on the external breaker. If the polarity is correct, the unit will power up. If the unit powers up, and the customer wants to enable the load circuit, they can then install the load fuse. The fuse does not need to be installed for the unit to function as a charger. If the battery cables are to be removed, remove power by turning off the external breaker and remove the fuse. Follow this procedure each time the battery is connected/disconnected. This fuse is supplied but not installed.



# The Kid Solar Charge Controller Instructions

## Aux input/output wiring:

This 2 position terminal block is the aux input/output. Functions such as Auto Gen Start, Low Battery Disconnect or the WhizBang Jr are connected here.

As new features are added they will be available at no cost at <http://www.midnitesolar.com/firmwareIndex.php>

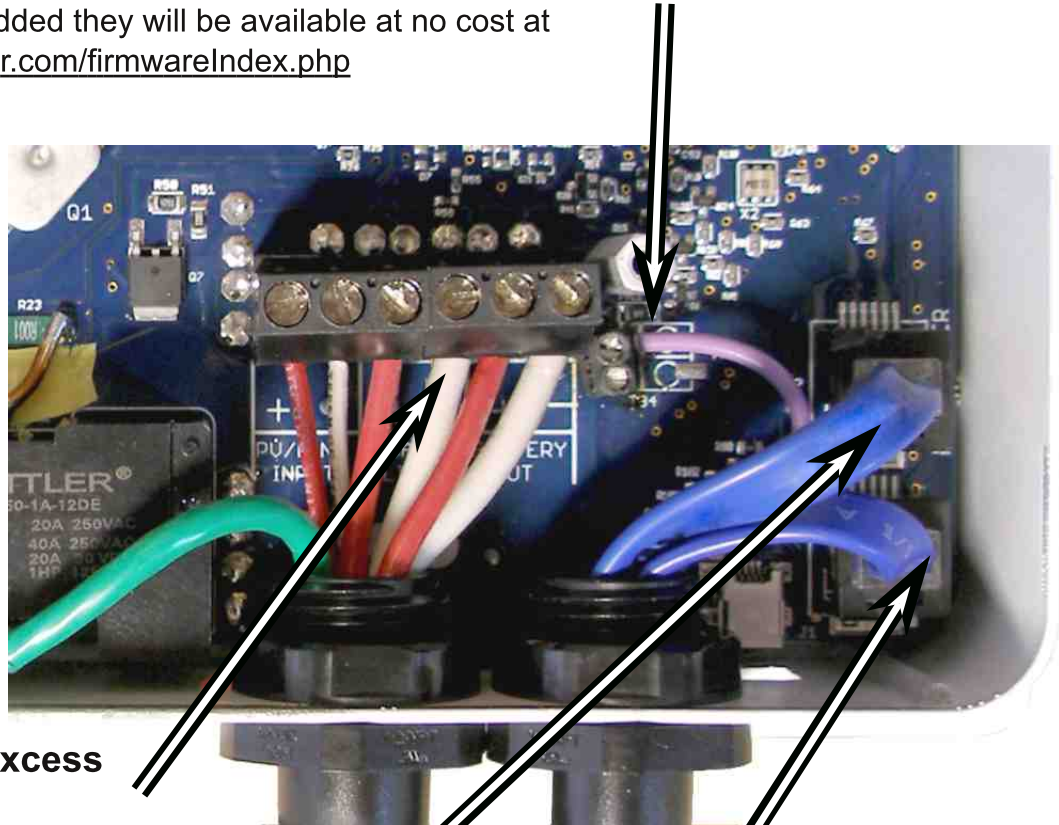

**Do not allow excess exposed wire**

**Stacking port**

**Battery temperature sensor plugged in**

**Sample wiring** showing PV, Load, Battery, Whizbang Jr., BTS and stacking cable. Wires may exit through either conduit fitting.



## Important!

The input and output negative connections must remain isolated. Failure to do so will cause inaccurate current readings and possible damage to the unit.

One Heyco part # M3200 strain relief is supplied for the power connections.

One Heyco part # UB-875 bushing is supplied for other connections.





# The Kid Solar Charge Controller Instructions



## Chassis Ground connection

The screw, nut and terminal for grounding the chassis are included on all models. The chassis ground (equipment ground) is required in an NEC compliant system. The chassis of the KID is isolated from all internal KID circuitry.

### Wiring the rest of the system:

Under the “Wiring diagrams” section of this manual there are seven different system configurations. 12, 24 and 48VDC systems are shown. These diagrams are based on common solar panels rated between 230 and 250 watts each, and a VOC of about 37 volts. (60 cell modules). These diagrams cover 95% of all combinations that will be used with the KID. Other solar panels are available and can certainly be used with the KID. Study the wiring diagrams to find the one that best suits your needs. You will see from 2 to 6 solar panels depending on system design and battery voltage. In a 12V system you will be limited to just two of these solar panels. The reason is that the KID has an absolute maximum output of 30 amps. Power is amps X voltage, so 30 amps output times 14 volts (charge voltage) = 420 watts. A 500 watt PV array would be a good match for a 12V system. You can always start with a smaller PV array and add to it at a later date. Keep in mind that PV voltage and current need to be matched closely in most cases. See the power graph at the end of this section. Battery voltage for the KID can be 12, 24 or 48 volts, so that means when you jump to a 24V battery bank, the KID can process twice the power than if it were connected to a 12V battery. In the case of a 48V battery, the KID can process 4 times the power of a 12V battery. Twelve volt batteries are used in marine and RV and very small Renewable Energy systems. When possible, it is better to go with a higher voltage battery bank, but that is usually not possible in a mobile application.



# The Kid Solar Charge Controller Instructions

## MNBTS Battery Temperature sensor



Standard on Marine versions, optional on All others. The published ratings of most batteries are made at 77 degrees F (25°C). Mother nature as well as man doesn't always allow the ambient temperature to hover around 25°C while charging batteries. Battery temperature sensors are employed on many sophisticated chargers in order to compensate the charge voltage based on temperature. If you are in an area where the ambient temperature is relatively stable at this temperature, you do not need a BTS (Battery Temp Sensor). If you live in Alaska or in the Sahara desert, you will want a BTS. It will prolong the life of your batteries. The BTS raises the charge voltage when colder than 77 degrees C and decreases the charge voltage above 77 degrees F.

Temp comp is set for lead acid batteries, but is adjustable for other types in the Battery menu.

### **Twin Mode:**

The KID stacking port is used for two things. When your power requirements grow and more charging current is required, you can add a second KID and have it act like a 60 amp controller. This requires that the PV input and battery output be paralleled, You accomplish this outside of the KID in a suitable junction box. See page 21 for stacking set-up. Make sure to use wire and breakers of suitable size for each KID. Since you will now have a 60 amp output capability, you might think that a single 60 amp breaker after combining the output is acceptable? However, each KID accepts 10AWG wire max. A 60 amp breaker does not protect 10AWG wire, so two 30 amp breakers will be required. The same situation exists for the PV input. Make sure that wires are not too small for the overcurrent devices.

14AWG = 15 amp breaker  
12AWG = 20 amp breaker  
10AWG = 30 amp breaker  
8AWG = 50 amp breaker  
6 AWG = 60 amp breaker



# The Kid Solar Charge Controller Instructions

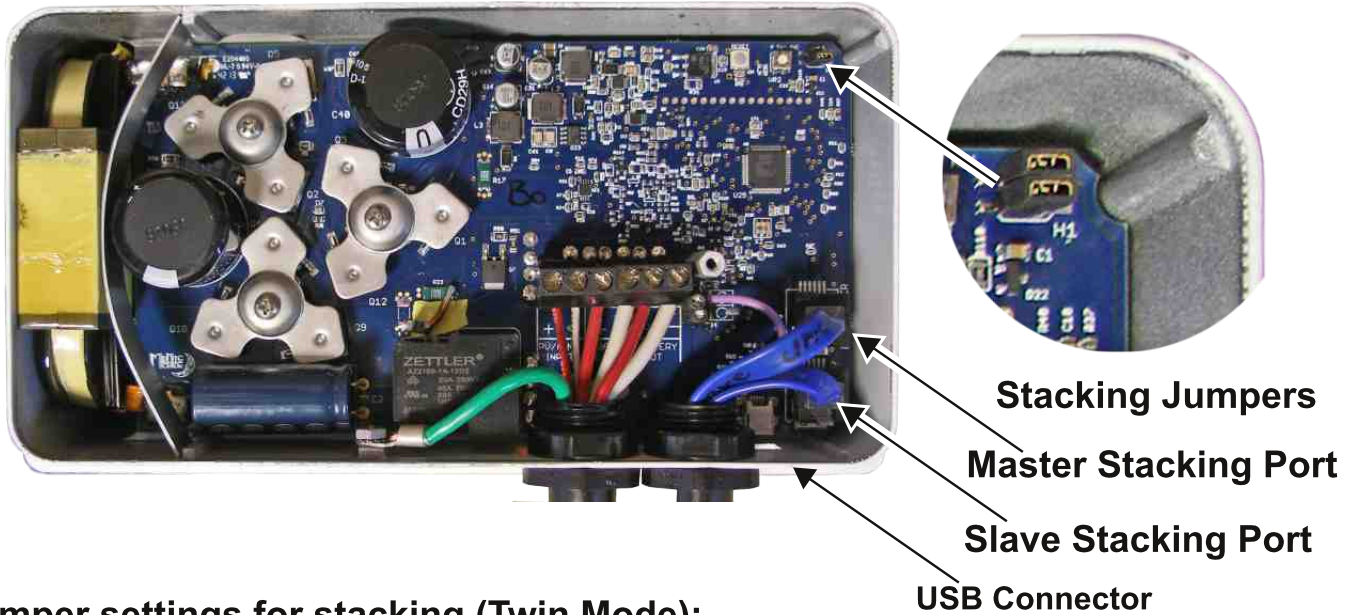

## Jumper settings for stacking (Twin Mode):

In the upper right corner of the circuit board there are two positions for placing jumpers. If not stacking (only one Kid) or stacking two Kids leave the jumpers off. The jumpers may be placed on one pin to be saved for later use. When stacking 3 or more Kids in "Follow Me" mode jumpers should be placed in both positions on the second and subsequent Kids. The jumpers should be oriented side to side (horizontally).

## Stacking Ports:

Connect a standard four conductor phone cable (Sold separately) between the **MASTER** jacks of the first two Kids.

If additional Kids are to be connected, connect a CAT5 cable (sold Separately) from the **SLAVE** Jack on the second Kid to the **Master** Jack the next Kid.

Continue in the same manner, **Slave** jack of one Kid to the Master Jack of the Next Kid in line. Up to 12 Kids may be connected in this manner.

## Serial communications from the stack port:

In the future you will be able to get serial data from the stack port. You cannot have a stacked pair of KIDS and serial data at the same time however. Firmware can be downloaded to upgrade the KID features at <http://www.midnitesolar.com/firmwareIndex.php>.



# The Kid Solar Charge Controller Instructions

## Set-Up and Use

These instructions are for firmware revision 1795. New features are added frequently.

Now that your KID is all wired up, solar panels in place and connected, battery bank installed and any loads connected, it is time to turn things on.

Get a digital meter. They can be had for as low as \$4.00 at Harbor freight, so there is no excuse to not have one. You will need one if support is ever required.

Check list:

Make sure all breakers are off. You didn't have them turned on while wiring did you?

Measure the battery voltage to insure you don't have a bad battery or bad connections. Read from Battery plus to battery minus to get your nominal voltage. A 12V battery should read between 11.5 and 13.00. By the way if it does read below 12V, that is not a good sign! Then measure it again at the KID terminals. It should be the same as at the battery.

Measure the output of the PV array from the PV minus to the PV plus at the point of connection at the PV input breaker. Then turn the PV input breaker on and measure at the KID terminal block PV+ to PV-. A 60 cell module should read about 37VDC. Two in series will read about 74. Three in series should read about 111. Don't worry if you are off by 10% or so. The PV Voltage needs to be about 30% higher than the battery Voltage in order to start charging.

Please do make sure that the panels are pointed at the sun, that the sun is completely on each panel with no shading and you are not inside of a garage. The sun must be illuminating the entire solar panel (s). You would be surprised how many people don't understand this concept. Our tech support people talk to them all the time. It is easy to avoid this situation.

Leave your Load breaker off for the moment.

**"Search Mode"**: The kid will perform a unit search the first time the unit is powered up for the first 5 seconds, if another unit found the unit will ask the user for the communication mode. The communication cable **MUST** be connected to the other unit and both units powered up for search mode to find other units in the system.

Turn on the battery breaker. If this is the first time it has been turned on, you will see this: if no other unit is found then the Kid will skip right to the Start up menu"



Battery Nominal  
Voltage is 12V

If your battery voltage is 12V, then hit the right arrow key to advance to the next set up selection. If you have a different battery voltage than what is displayed, then hit the up or down arrow key until the desired nominal battery voltage is displayed. Once the correct voltage is displayed, hit the right arrow key.



## The Kid Solar Charge Controller Instructions

The next set of screens are where you select battery type. Selecting the applicable battery type sets some important parameters that are specific to different battery chemistries. The first choice is Flooded. Use the up arrow to see all the choices. Listed below.

Battery Type  
Flooded →

Battery Type  
AGM →

Battery Type  
GEL →

Battery Type  
Calcium →

Battery Type  
Lithium →

Battery Type  
Custom →

Stop on the correct battery type and then hit the right arrow key. It then takes you to the absorb voltage screen.

Battery Absorb  
14.3 Volts →



# The Kid Solar Charge Controller Instructions

When the absorb screen appears, use the up/down arrow to adjust absorb voltage. Consult your battery manufacturer for their recommended settings. There is no such thing as one setting that fits all flooded or AGM etc. batteries. Different manufacturers have different requirements. Differences may be subtle, but the KID is capable of very fine adjustment. There is no reason to guess as to these important settings. When done, hit the right arrow key to go to the Float settings screen.

Battery Float  
13.9 Volts →

Setting the Float voltage is accomplished exactly the same as the previous Absorb voltage. Use the up down arrows to adjust the float voltage according to your battery manufacturer's recommendations. When done, hit the right arrow key to bring you to the Equalize screen.

Battery Equalize  
15.0 Volts →

Default is 15.0 volts. This is not high enough to EQ a flooded battery, but not so high that it would hurt a Gel or AGM style battery which is why the EQ default setting is intentionally set low. Flooded batteries require periodic Equalizing to reduce sulfation. Consult your battery manufacturers specifications for a correct EQ setting. If your type of battery does not want to ever be EQ'd, then simply set the voltage to the Absorb voltage.

When done, hit the right arrow key to bring you to the Input Function screen.

Input Function  
Solar →

This screen is where you select what type of charge controller you will configure the KID for. Solar is the most common. Use the up /down arrow keys to select Solar, then hit the right arrow key. The screen changes to say DATA HAS BEEN SAVED and then switches to a status screen.

0.0 Resting  
12.4V Solar 0W



# The Kid Solar Charge Controller Instructions

**STATUS BUTTON:** There are a few status screens available at the touch of the Status button. The first (left) screen shows:

9.5A BULKMPPT  
12.7 Solar 257W

The 9.5a as depicted above represents the battery output current. BULKMPPT shows the state that the charger is in. BULKMPPT means the KID is going all out to put all available energy into the batteries. The 12.7V represents battery voltage. The SOLAR shows it is in Solar mode. The 257W shows the instantaneous wattage going into the battery. push the right arrow key to bring up the second status screen shown below.

Input Battery  
59.6V 13.5V

This second status screen is showing the PV array voltage and battery voltage. The PV array voltage corresponds to the Max power voltage from the PV array for the present conditions. Push the right arrow key to bring up the third **status** screen.

9.5a SOC 93%  
372Ah Remai ni ng

This third status screen is showing input from the WBJr.. In this display 9.5 amps are going to the batteries, State of Charge is 93% and 372 Amp hours remain in the batteries. Push the right arrow key to bring up the fourth **status** screen.

Load: Manual  
0.0a Off

This fourth status screen is showing what mode the Load is in, the current that the load is drawing and whether the load is on or off. Push the right arrow key to bring up the fifth **status** screen.

KWhr Kid Ahr  
0.0 0.0

This fifth status screen is showing daily power produced in Kilowatt hours and Amphours.



# The Kid Solar Charge Controller Instructions

## Status Screens.

The Kid has several status display screens showing voltage, charge mode, temperatures, currents and voltages. These screens are displayed any time that the LCD is on and you are not in a menu. If you press the STATUS button the following screens will be displayed. The first screen is displayed by default and the others are available by pressing the right arrow. The left arrow will step back through the status display screens.

0.0A Resting  
13.7 Solar OW

Input Battery  
5.4V 13.7V

0.0a SOC 100%  
400Ah Remai ni ng

Load: Manual  
0.0a Off

KWhr KID Ahr  
0.0 0.0

When The Kid has been idle for five minutes the display will cycle through the following screens. Each screen will display for a few seconds and then advance to the next.

You may push the arrow keys anytime while The Kid is cycling through these screens to return to manually stepping through the status screens shown above. The STATUS and MENU BACK buttons are always available. Scrolling may be disabled in the LCD Menu.

0.0A Resting  
13.7 Solar OW

Input Battery  
5.4V 13.7V

KWhr KID Ahr  
0.0 0.0

0.0a SOC 100%  
400Ah Remai ni ng

CPU FET Batt  
25c 23c 23c





# The Kid Solar Charge Controller Instructions

## The Kid's L.E.D.s.

<b>RFC</b> ●	<b>RFC</b> - Received Full Charge. The battery has received a full charge.
<b>1WK</b> ●	<b>1WK</b> - One Week. It has been one week since a full charge.
<b>2WK</b> ●	<b>2WK</b> - Two Weeks. It has been two weeks since a full charge.
<b>FLT</b> ●	<b>FLT</b> - Float. The battery is in float charge.
<b>OVR</b> ●	<b>OVR</b> - Over Voltage. The kid has detected an overvoltage.
<b>ERR</b> ●	<b>ERR</b> - Error. The kid has stopped due to an error or generator did not start.
<b>CLP</b> ●	<b>CLP</b> - Displays Load On/Off.

The Kid has several L.E.D.s to indicate modes and errors.

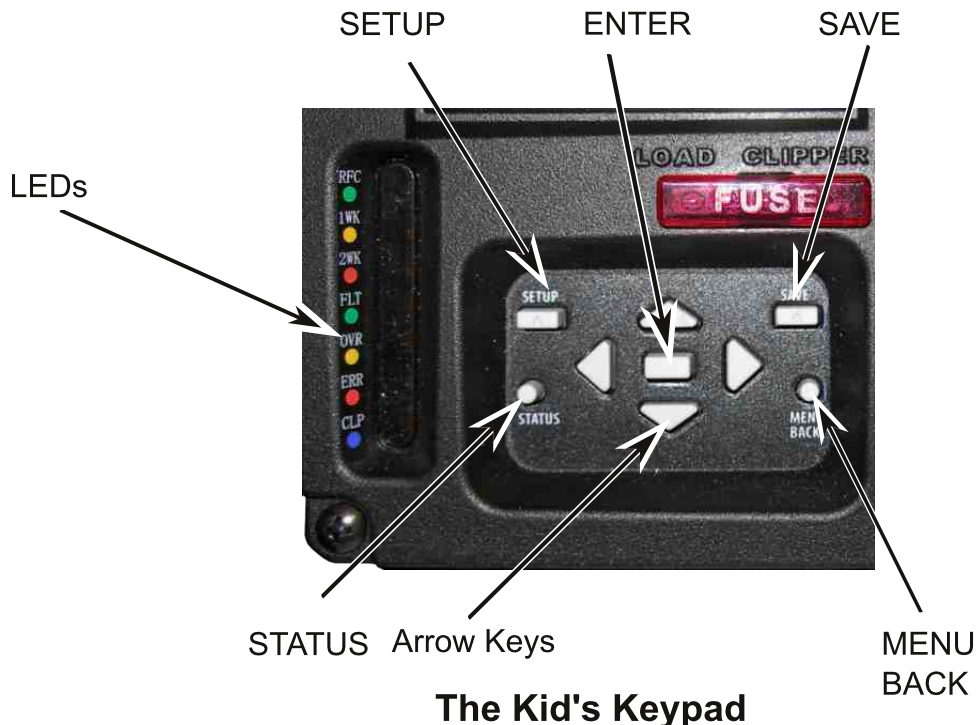



# The Kid Solar Charge Controller Instructions

## MAIN MENUS:

The KID has 7 MAIN MENU headings. This section deals with the MAIN MENU headings only. See INSIDE THE MAIN MENU for what is inside each of the 7 menus.

Hit the MENU/BACK key. This button takes you to all of the Main Menus. Main menus are something you want to become familiar with. No matter where you are at in any menu, you can always get to the Main Menus by hitting this button once or twice.

You scroll through Main Menus from left to right. The left most Main Menu is as follows.

Adjust Setpoint  
<Battery> Load

Notice the word BATTERY is in brackets. That means the BATTERY menu will be activated if the ENTER button is pushed. The BATTERY menu allows you to set all battery charging parameters just like what was done in the initial set up.

The BATTERY menu has additional adjustments beyond what the initial set up had. After the first time activating the KID, this is the way to change Battery charging parameters.

The adjustments and settings available inside the BATTERY menu are:

- Absorb voltage settings
- Float voltage settings
- Equalize voltage settings
- Amp limits for battery charging and load draw
- Temperature compensation adjustability
- Temp comp during EQ

### Manual EQ:

Note: Auto EQ is not available on The Kid.

Manual EQ allows the user to trigger an Equalize (EQ) cycle manually.

There are two parameters to set before you can equalize, EQ voltage and EQ time.

Refer to the battery manufacturer's recommendations for equalizing voltages and times.

### To set EQ parameters:

Press **Main Menu** and select **Battery**,

Go to **EQ** and press **Enter**,

Press the **SETUP** Button to adjust the EQ Voltage and Time.

### To start a manual EQ cycle:

Press **Main Menu** and select **Battery**,

Go to **EQ** and press **Enter**,

Select **START**,

The EQ Cycle will begin.



# The Kid Solar Charge Controller Instructions

---

## Battery Charge Stages and Meanings

### **Bulk MPPT**

This stage of The Kid means; that The Kid will be putting out as much current as it can trying to charge the batteries to the absorb voltage set point. This is also known as constant current mode.

### **Absorb**

This stage means that The Kid will maintain the absorb set point voltage until the batteries are charged or it reaches Float stage. At this stage The Kid is not putting out maximum current, as that would increase the battery voltage over the Absorb set point. This is also referred to as constant voltage mode. The battery is considered “full” at the end of the absorb charge cycle.

The absorb time is proportional to the bulk time. (i.e. the time bulk takes to reach the absorb voltage.) The battery it’s considered “full” at the end of the absorb charge cycle.

### **Float**

A Float cycle follows after the Absorb cycle is completed; Float is displayed on the screen. Battery voltage is held at the float voltage set point, float time can be changed by the user.

### **Equalize**

The intent of an equalization charge is to bring all battery cells to an equal voltage by a deliberate overcharge. The goal is to return each battery cell to its optimum condition through a series of voltage controlled chemical reactions inside the batteries.



# The Kid Solar Charge Controller Instructions

## Advanced Battery Settings:

Located under the “**Battery**” menu a submenu labeled “**Advanced**”. This menu contains advanced charge settings.

### EndAmps:

Best results are obtained when a Whiz Bang Jr. (Sold Separately) is connected to the kid.

*End Amps* refers to the amount of current flowing to the batteries. When End Amps are set, this function will act as a secondary termination to the absorb timer.

The End Amps function works by monitoring the current going into the batteries during the absorb stage. As the batteries charge, the current needed to maintain the Absorb voltage set-point reduces and depending on the battery bank type and size there is a current flow level that indicates that the batteries are full. End Amps are that level, if the current flow goes below the End amps setting for one minute then the Absorb cycle will be terminated and it will go to Float stage.

### Shunt Selection:

Selecting between the internal shunt and the optional Whiz Bang Jr. is found in the “Calibration” menu. From the main menu **TECH - Calibration**.

### Rebulk:

Rebulk is the Voltage set-point at which the Float stage will terminate and return to Bulk.

In Float, the Kid will return to Bulk if a load placed on the battery bank reduces the battery bank voltage below the Rebulk set point for two minutes.

## The Kid as a load controller:

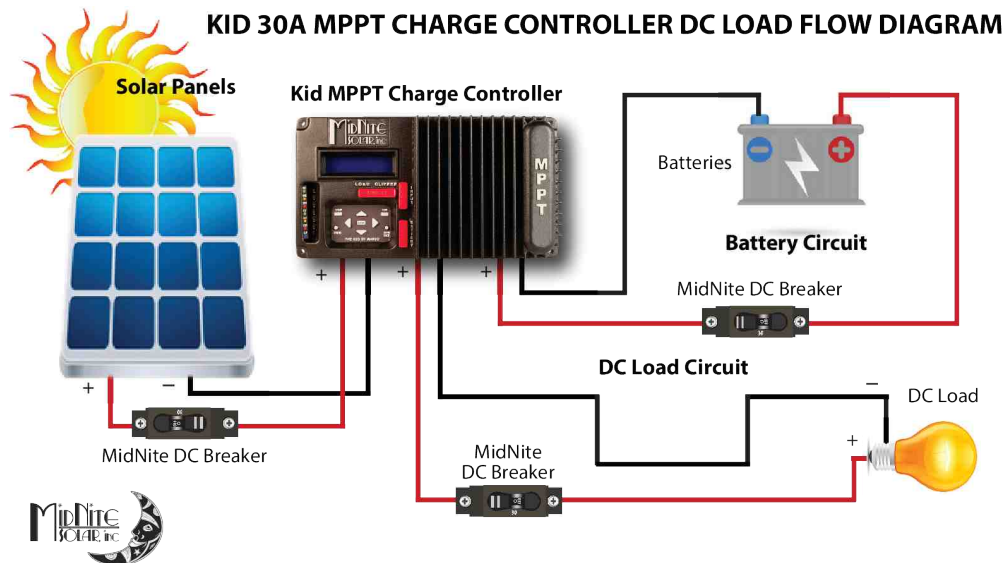

NOTE: This is not intended as a wiring diagram and is used only to display basic wiring concepts.

MidNite Solar Inc. 17722 - 67th Ave NE Arlington, WA 98223 PH. 360-403-7207

[www.midnitesolar.com](http://www.midnitesolar.com)



# The Kid Solar Charge Controller Instructions

## Load Menu:

All loads to be controlled by The Kid are connected to the LOAD terminals of the main KID terminal block. Note that this output is not intended to control an inverter or other large load. If it is necessary to control a larger load then use the Kid to control a relay. The relay will then switch the load. Programming the Load Functions determine how and where the load is connected.

Scrolling to the right will bring you to the **LOAD** menu.  
This is the LOAD Main Menu. It allows numerous types of load functions.

```
SET LOAD/CLIPPER  
BATT<LOAD>INPUT
```

The first screen is Manual on/off. Use the up/down arrow keys to select other modes

```
Func: Manual  
*Off On
```

## Load Current Limit:

The current limit on the load can be set by the user. Whenever the user current limit is reached the load will turn off for about 10 seconds, it will then try again. If the Max allowable current (30 amperes) is exceeded, the Load will be turned off and kept off for 3 minutes. It will retry, if the overload condition is still present, it will stay off for another 3 minutes. The Kid will continue to cycle until the overload condition is removed. In the Load Status screen it will Say "**Over Current!**" and the blue LED will blink. To adjust the Load Current limit:

- Press **Main Menu**, select **Battery** and Press **Enter**.
- Select **AmpLmt** and press **Enter**.
- Select **Load** and use the **Up** and **down** buttons to adjust the limits.
- Press **SAVE** Button to save the adjustment.



# The Kid Solar Charge Controller Instructions

---

## Load Control Modes

The load control output is a very versatile feature. Some of the basic uses are explained here.

- **Manual Mode** - The load is turned on and off manually from the Kid control panel. The load will also disconnect when the low voltage disconnect setting is reached.
- **Dusk + Time** - In this mode the load is turned on at dusk. The load then remains on for the amount of time selected. The solar clock helps determine when dusk is and adjusts for the seasons.
- **Night Light** - When selected the load is turned on at dusk and off at dawn.
- **Day Light** - When selected the load is turned on at dawn and off at dusk.
- **PWM Divert** - This mode will maintain three stage charging while making excess power available to the load.
- **Float On** - In this mode the load is turned on when the batteries go to float.
- **Float Off** - In this mode the load is turned off when the batteries go to float.
- **Diversion** - When there is more power available than the batteries can use this excess power can be used to run opportunity loads.
- **Toggle** - This is a test mode. The load will be turned on and off twice per second.
- **NightVarOFF** - The load will be turn on at dusk and it will stay on for the time specified. The load will then turn on the specified hours before dawn, turning off again at dawn.
- **Hourly** - In this mode the loads are turned on and off based on time of day. The Kid's internal clock is adjusted daily based on sunrise and sunset times and is approximate.

Every night the clock re-adjusts the time by using the PV panels to detect dusk and dawn, the time is only an estimate and it does not take into account Daylight Savings Time.

For example, if in spring you set The Kid to turn the load on at 6:00 P.M. and off at 8:00 P.M. and dusk is at 5:30 P.M. The load would turn on at 6:00 P.M. and would turn off at 8:00 P.M.

As the sunset time gets later than the turn on time, the turn on time would then be at dusk and the turn off time will remain at 8:00. Should dusk come after 8:00 P.M. the load would not come on.

On that sad, sad day after the solstice when the daylight hours start getting shorter again, as dusk returns to 6:00 P.M. or earlier the turn on time would again be 6:00 P.M. The turn off time will remain at 8:00 PM while dusk could be at 5:13 or earlier.

To select the on time and off times press **MENU BACK**, select **LOAD** and press the up arrow until the display shows **HOURLY** then press **SETUP**.



# The Kid Solar Charge Controller Instructions

## Load Functions detailed Description

**-FUNC: Manual - ON/OFF** - This Mode can be turned On or Off by the user Manually, and the Load circuit will act accordingly, this Mode can be Used with the Low Battery Disconnect safety monitoring.

To use Manual Mode:

- From the Status Menu: Press Menu Back
- Scroll to the Right and select Load and Press Enter
- Select FUNC: Manual
- Press the Right button to \*ON - The load will turn on and stay on until turned off.
- Press the Save Button
- Press SETUP button to Bring up LBD setup (see **LBD Low Battery Disconnect** for more details).

**-FUNC: Dusk + Hrs - OFF/AUTO** - This Function will become active when night comes and it will stay On for the number of hrs set up by the user, then the load will turn Off.

To use Dusk + Hrs:

- From the Status Menu: Press Menu Back
- Scroll to the Right and select Load and Press Enter
- Select FUNC: Dusk + Hrs
- Press the Right button to \*AUTO - The load will turn on and off as set by the user.
- Press the Save Button
- Press SETUP button adjust the amount of Hrs to stay on.
- Press the Save Button

**-FUNC: Night Light – OFF/AUTO** – This function will turn on the load when night comes and it will turn it off when the sun comes up, this Mode can be Used with the Low Battery Disconnect safety monitoring.

To use Night Light Mode:

- From the Status Menu: Press Menu Back
- Scroll to the Right and select Load and Press Enter
- Select FUNC: Night Light
- Press the Right button to \*Auto
- Press the Save Button
- Press SETUP button to Bring up LBD setup (see LBD section for more details).

**-FUNC: Day Light – OFF/AUTO** – This function will turn on the load when the sun comes up and it will turn off when the sun goes down, this Mode can be Used with the Low Battery Disconnect safety monitoring.

To use Day Light Mode:

- From the Status Menu: Press Menu Back
- Scroll to the Right and select Load and Press Enter
- Select FUNC: Day Light
- Press the Right button to \*Auto
- Press the Save Button
- Press SETUP button to Bring up LBD setup (see LBD section for more details).

**-FUNC: PWM Divert – OFF/AUTO** – This function will divert excess power to the load when extra



# The Kid Solar Charge Controller Instructions

power is available and it will maintain 3 stage battery charging. There are 2 parameters that can be adjusted when Pressing the SETUP button; Offset and Width

Offset: This is in voltage, and refers to an Offset from the current battery voltage Set point, for example if the battery charging stage is Absorb then the Offset is taken from the Absorb set point, in the same manner it will be taken from the other Stages also it takes into account if the Battery temperature sensor is plugged in and set up.

Width: This is in voltage and refers to the volts the transition will take, from On to Off and vice-versa.

To use PWM Divert Mode do the Following:

- From the Status Menu: Press Menu Back
- Scroll to the Right and select Load and Press Enter
- Select FUNC: PWM Divert
- Press the Right button to \*ON
- Press the Save Button
- Press SETUP button to adjust the Offset and Width set points.

- **FUNC: Float ON:** The Load will be turned on when the battery state of charge is Float and it will turn off when the state of charge is any other than Float

To use Float On Mode do the Following:

- From the Status Menu: Press Menu Back
- Scroll to the Right and select Load and Press Enter
- Select FUNC: Float On
- Press the Right button to \*Auto
- Press the Save Button

- **FUNC: Float OFF:** The Load will be turned off when the battery state of charge is Float and it will turn on when the state of charge is any other than Float

To use Float Off Mode do the Following:

- From the Status Menu: Press Menu Back
- Scroll to the Right and select Load and Press Enter
- Select FUNC: Float Off
- Press the Right button to \*Auto
- Press the Save Button

-**FUNC: Diversion – OFF/AUTO** – This function will divert excess power to the load when extra power is available. This mode is not PWM based. There are 2 parameters that can be adjusted when Pressing the SETUP button; VoltOn and VoltOff

VoltsOn: This is the absolute voltage, at which the load will be turned on

VoltsOff: This is the absolute voltage, at which the load will be turned off

To use Diversion Mode do the Following:

- From the Status Menu: Press Menu Back
- Scroll to the Right and select Load and Press Enter
- Select FUNC: Diversion
- Press the Right button to \*ON
- Press the Save Button
- Press SETUP button to adjust the VoltsOn and VoltsOff set points.

-**FUNC: Toggle Test – OFF/AUTO** – This Mode is for testing purposes only, it will turn the load On and





# The Kid Solar Charge Controller Instructions

Off at twice per second.

**-FUNC: LVD Alarm – OFF/AUTO** - This mode will turn on if the battery voltage goes below the AlrmON set point and turn OFF if it goes above the AlrmOFF Set point.

- From the Status Menu: Press Menu Back
- Scroll to the Right and select Load and Press Enter
- Select FUNC: LVD Alarm
- Press the Right button to \*ON
- Press the Save Button
- Press SETUP button to adjust the VoltsOn and VoltsOff set points.

**Note:** the AlrmOn/AlrmOFF setpoints are independent from those on the AUX Port.

**-FUNC: NightVarOff – OFF/AUTO** - Turns the load on for a user selected amount of time after dusk and before dawn.

- From the Status Menu: Press Menu Back
- Scroll to the Right and select Load and Press Enter
- Select FUNC: NightVarOff
- Press the Right button to \*Auto
- Press the Save Button
- Press SETUP button to adjust the how long after dusk and before dawn the load will be turned on.

**-FUNC: Hourly – OFF/AUTO** - In this mode the clock re-adjusts the time every night by using the PV panels to detect dusk and dawn, the time it is only an estimate and it does not take into account DST.

- From the Status Menu: Press Menu Back
- Scroll to the Right and select Load and Press Enter
- Select FUNC: Hourly
- Press the Right button to \*Auto
- Press the Save Button
- Press SETUP button to set the time the load will turn on and off.

## **LBD - Low Battery Disconnect:**

The kid includes an adjustable Low battery Disconnect function which allows the user to set an absolute discharge limit when using a daily function such as Night Light and the life of the batteries doesn't want to be compromised, it also includes a reconnect voltage set point or it could be reconnected when Float has been reached, ensuring that the batteries have been fully charged after a LBD (Low Battery Disconnect).

If a LBD state has occurred the blue LED will blink slowly.

To set up these parameters:

- Press Menu Back button
- Scroll to the right and select <Load> and press Enter
- Press the Setup button
- If OFF appears under the names Lowbatt and Reconn it means the feature is currently disabled.
- Press the Right button to enable the function, now two numbers will appear under the names
- Press the Left, Right, Up and Down keys to adjust the voltages as needed for your battery type
- To enable reconnect on Float stage go to Reconn and Press the Right key again and the word FLOAT



# The Kid Solar Charge Controller Instructions

will appear under Reconn (Float voltage can be configured in the Battery menu).  
-Press the Save button to keep the changes on non volatile memory of The Kid.  
Refer to the battery manufacturers recommended settings.

## Input Menu:

ADJUST MPPT MODE  
LOAD <I NPUT> AUX

The INPUT MENU is where you turn the KID on and off. There are different selections for how the KID will track your Solar system. Selections are below:

**Note:** Mode must be manually turned ON after changing the mode.

To turn the Mode on highlight the OFF under ON/OFF and switch it to ON. Press the Save to save this change. Press menu back when done. Modes will revert to OFF if the up or down arrows are pressed before exiting.

### Solar

This is the default mode for PV systems and has a very fast sweep (typically 1/2 second or less) that will re-sweep at user adjustable sweep intervals, unless the Kid finds that it needs to do a sweep on its own because of changing conditions. The timed sweep interval is user adjustable and is in units of minutes. SOLAR mode is typically best for PV systems, especially if there is partial shading at times during the day. SOLAR mode is best suited for shaded or un-shaded PV arrays that are at least one nominal voltage above the battery voltage. For severe partial shading or PV arrays with nominal voltage equal to battery voltage, you may also want to try Solar 2 O&P (Observe and Perturb) MPPT mode. Press Save then press menu back when done. Modes will revert to OFF if the up or down arrows are pressed before exiting.

### Solar2 O&P

(Observe and Perturb) mode is a slow tracking mode. This is typically used for PV (solar) input sources and tries to follow, on a slow dynamic basis, the changing conditions of the input source. This mode has one user adjustment which is a forced sweep perturb trigger interval for times when the input condition changes do not trigger a dynamic sweep. Press Save then press menu back when done. Modes will revert to OFF if the up or down arrows are pressed before exiting.

### U-SET VOC%

This is a fully manual mode based on a percentage of VOC. The Classic will sweep based on the user set time in minutes and then park at a user set % of the VOC the Classic found on that sweep. This mode is useful for testing or constant voltage sources. Press Save then press menu back when done. Modes will revert to OFF if the up or down arrows are pressed before exiting.



# The Kid Solar Charge Controller Instructions

Hit the right arrow to advance to the **AUX MAIN MENU**.

**SETUP AUX FUNCTION  
LOAD <AUX> MISC**

The AUX menu is where you set up various auxiliary input and output functions such as Auto Genstart, Low Battery Disconnect and the Whizbang Jr. Battery status monitor.

**Note:** Mode must be manually turned ON after changing the mode.

To turn the Mode on highlight the OFF under ON/OFF and switch it to ON. Press the Save to save this change. Press menu back when done. Modes will revert to OFF if the up or down arrows are pressed before exiting.

**FUNC: WBJR OFF/AUTO** - Enable/Disable/Setup the WBJR

- From the Status Menu: Press Menu Back
- Scroll to the Right and select AUX and Press Enter
- Select FUNC:WBJR
- Press the Right button to Auto.
- Press the Save Button
- Press SETUP button to set the Battery Capacity.  
scroll to the right to set Battery Efficiency.  
Scroll right to set the Battery Temp Ref.  
Scroll right to set the Battery Change %.
- Press the Save Button.

**FUNC: Gen Start OFF/AUTO/ON** - Enable/Disable/Setup Auto Generator Staring

To use Gen Start:

- From the Status Menu: Press Menu Back
- Scroll to the Right and select AUX and Press Enter
- Select FUNC:Gen Start
- Press the Right button to Auto or \*ON
- Press the Save Button
- Press SETUP button to set the battery voltage threshold to start the generator.  
scroll to the right to set the Gen Start delay.  
Scroll right to set the Min Gen Runtime.  
Scroll right to set the Max Gen Runtime.  
Scroll right to set the Gen Run Confirm Voltage.
- Press the Save Button

**FUNC: LBD High OFF/AUTO** - Enable/Disable/Setup Low Battery Disconnect High

- From the Status Menu: Press Menu Back
- Scroll to the Right and select AUX and Press Enter
- Select FUNC:LBD High
- Press the Right button to Auto.
- Press the Save Button
- Press SETUP button to set the AlrmON Voltage. scroll to the right to set AlrmOFF Voltage.
- Press the Save Button.



# The Kid Solar Charge Controller Instructions

**FUNC: LBD Low OFF/AUTO** - Enable/Disable/Setup Low Battery Disconnect High

- From the Status Menu: Press Menu Back
- Scroll to the Right and select AUX and Press Enter
- Select FUNC:LBD Low
- Press the Right button to Auto.
- Press the Save Button
- Press SETUP button to set the AlrmON Voltage. scroll to the right to set AlrmOFF Voltage.
- Press the Save Button.

Hit the right arrow key to advance to the **MISC** menu.

OTHER STUFF  
AUX <MISC> COMM

The MISC menu allows adjustment for:

**LCD** - Backlight and contrast controls can be adjusted with the up/down buttons

**Temp** - Status of CPU, FET and Battery in degrees C

**LEDS** - Rick mode (minimal lights) and Off

**Timer** - Shows time accrued.

**Password** - Enable/Disable Password

Hit the right arrow key to advance to the **COMM** menu.

MULTIPLE UNITS  
MISC <COMM> TECH

The COMM menu is where stacking is set up. Your choices are Twin Mode and Sync.

**Note:** On earlier units *Twin Mode* was known as *Bully Mode* and *Sync Mode* was known as *Follow Me*.

**Twin Mode:** is true paralleling where the inputs and outputs are paralleled. You are allowed only two KIDS in Twin mode. This is a Master/Slave configuration. The Master Twin tells the second Kid what to do. Sync Mode is where the outputs are paralleled, but each input has its own PV array. Twin mode only works when two kids are connected.

**Sync Mode:** When any one of the KIDS change state, Absorb, Time, Float or Equalize it sends a signal downstream to the next one to follow and change state. Then the second one sends the same message downstream and so on until it finally comes back around the communications circle and all units are in the new state. There is no limit to how many controllers can be connected in Sync mode. Both Sync and Twin mode are MidNite Solar exclusive methods of applying multiple controllers.



# The Kid Solar Charge Controller Instructions

## ADVANCED MENU COMM <TECH>

Hit the right arrow key to advance to the **TECH** menu. The TECH menu is for tech savvy individuals.

**Calibrate:** You can calibrate the battery voltage offset as well as the Input voltage offset to read the same as your Fluke meter. In this menu you may also set/adjust - Anti Click Sensitivity, EndAmp Shunt Sel, Pre Matching, Min Low Power and NightLight on PV.

### Calibrate Menu:

**Battery V OFFSET** - Adjusts the battery voltage display on The Kid to match a digital multi-meter.

**Input V OFFSET** - Adjusts the PV voltage display on The Kid to match a digital multi-meter.

**AntiClick Sensit:** - Adjusts the input threshold at which The Kid starts charging.

**EndAmp Shunt Sel:** - Selects between The Kid's internal shunt and the (optional) WBJr's shunt.

**Pre Matching:** This setting is to be only changed from the default value if indicated by a MidNite Solar Tech, the default Value is 0.8

**Min Low Power:** The minimum power the unit has to be producing to be kept on, default is 10 watts.

**NightLight on PV:** - Adjusts The Kid's night detection. Helpful when lights shine on the panels at night.

**Battery V OFFSET** - Adjusts the battery voltage display on The Kid to match a digital multi-meter.

### To adjust the settings:

\*Press Menu back

\*Scroll to the right then select TECH and press Enter

\*Select Calibrate and press Enter

\*Press the left/right arrow until Battery V OFFSET is on the top line of the LCD

\*Use the Up and Down buttons to adjust to the desired setting

\*Press the SAVE button to keep the settings.

**Input V OFFSET** - Adjusts the PV voltage display on The Kid to match a digital multi-meter.

### To adjust the settings:

\*Press Menu back

\*Scroll to the right then select TECH and press Enter

\*Select Calibrate and press Enter

\*Press the left/right arrow until Input V OFFSET is on the top line of the LCD

\*Use the Up and Down buttons to adjust to the desired setting

\*Press the SAVE button to keep the settings.

### AntiClick Sensitivity:

This setting refers to the input voltage from the panels that the Kid will sweep down to from VOC when trying to figure out if there is enough power for the unit to turn on, the higher the number is set to the less the relay will click(less sensitive) at sunrise and sunset, but if the number is set too high then, the unit might not turn on even when there is enough power available to charge the batteries. The lower



# The Kid Solar Charge Controller Instructions

that the number is set the unit will click more frequently, and may turn on sooner (with less power available). If you do not understand this setting, do not change from the factory default setting (8.0), unless instructed from MidNite Solar personal Tech Support.

## To adjust the settings:

- \*Press Menu Back
- \*Scroll to the right then select TECH and press Enter
- \*Select Calibrate and press Enter
- \*Press the right arrow until AntiClick Sensitivity is on the top line of the LCD
- \*Use the Up and Down buttons to adjust to the desired setting
- \*Press the SAVE button to keep the settings.

**EndAmp Shunt Sel:** - Selects between The Kid's internal shunt and the (optional) WBJR's shunt.

## To adjust the settings:

- \*Press Menu Back
- \*Scroll to the right then select TECH and press Enter
- \*Select Calibrate and press Enter
- \*Press the right arrow until EndAmp Shunt Sel is on the top line of the LCD
- \*Use the Up and Down buttons to adjust to the desired setting
- \*Press the SAVE button to keep the settings.

## Pre Matching:

### To adjust the settings:

- \*Press Menu Back
- \*Scroll to the right then select TECH and press Enter
- \*Select Calibrate and press Enter
- \*Press the right arrow until Pre Matching is on the top line of the LCD
- \*Use the Up and Down buttons to adjust to the desired setting
- \*Press the SAVE button to keep the settings.

Do not adjust this setting unless directed to do so by MidNite Solar Tech Support.

## Min Low Power:

### To adjust the settings:

- \*Press Menu Back
- \*Scroll to the right then select TECH and press Enter
- \*Select Calibrate and press Enter
- \*Press the right arrow until Min Low Power is on the top line of the LCD
- \*Use the Up and Down buttons to adjust to the desired setting
- \*Press the SAVE button to keep the settings.

**NightLight on PV:** This setting is for adjusting The Kid's sensitivity to ambient light. In the event that your night lights shine on the panels this setting adjusts the threshold of light required to



# The Kid Solar Charge Controller Instructions

turn off loads to prevent cycling.  
The night detect has 3 different profiles.

**Profile 1:** This setting looks at the PV voltage to be above the battery voltage plus some volts for the MPPT to try to produce power (this is the default Setting).

**Profile 2:** The unit will look through the day for the highest Voltage Open Circuit (unloaded) of the PV and the Minimum turn on voltage will depend on the VOC% setting (adjustable). The VOC for this setting does not take into account How much power if any, was produced.

**Profile 3:** This setting will look through out the day at the VOC but Only if the power produced has been more than the Min Low Power. Then it will take the VOC % setting and that will become the minimum required PV voltage for the unit to detect a Daylight.

**NightLight VOC%:** This is the VOC % to detect if there is enough sunlight or ambient light shining on the PV to detect day VS Night. The Default is 90%.

## To adjust the settings:

- \*Press main Menu
- \*Scroll to the right then select TECH and press Enter
- \*Select Calibrate and press Enter
- \*Press the right arrow until NightLight on PV Sensitivity is on the top line of the LCD
- \*Use the Up and Down buttons to adjust to the desired setting
- \*Press the SAVE button to keep the settings.

**Reset to factory defaults.** Setting things back to factory defaults is useful after your brother in law was observed messing with all the buttons and you can't trust what he did. So, reset and start over entering all the settings you know you want.

## Firmware.

To do a firmware update on the kid you will need the following:

- A laptop or PC with Windows XP/7/8/8.1 or Linux. Mac is not supported.
- A USB Mini-B cable (not included).

Procedure:

- Go to <http://www.midnitesolar.com/firmwareIndex.php> and download the latest firmware file.
  - Save the file to a known location on your PC (eg. Desktop \).
  - Plug in the USB cable to the Kid connector located on the bottom of the unit.
  - Plug the other end into an available USB port on the PC.
  - Go to MAIN Menu on the Kid And scroll to the right to the TECH menu and press Enter.
  - Press the down arrow key until Firmware Update is selected and press Enter.
  - After 5 sec the unit will turn off and display FIRMWARE UPDATE.
  - A new empty drive will appear in your PC, open it.
  - Drag the downloaded file to this empty drive.
  - The first green light should start blinking on the Kid and "UPDATING..." should appear on the second line.
  - It will take up to 2 minutes to update the kid.
- The unit will reboot with new updated firmware.
- Unplug the USB cable.

## About Kid CC:

Shows the current BootLoader and FirmWare versions.



# The Kid Solar Charge Controller Instructions

**KID 30A MPPT CHARGE CONTROLLER SIMPLE FLOW DIAGRAM WITH AUTO GENSTART AND WHIZBANG JR.**

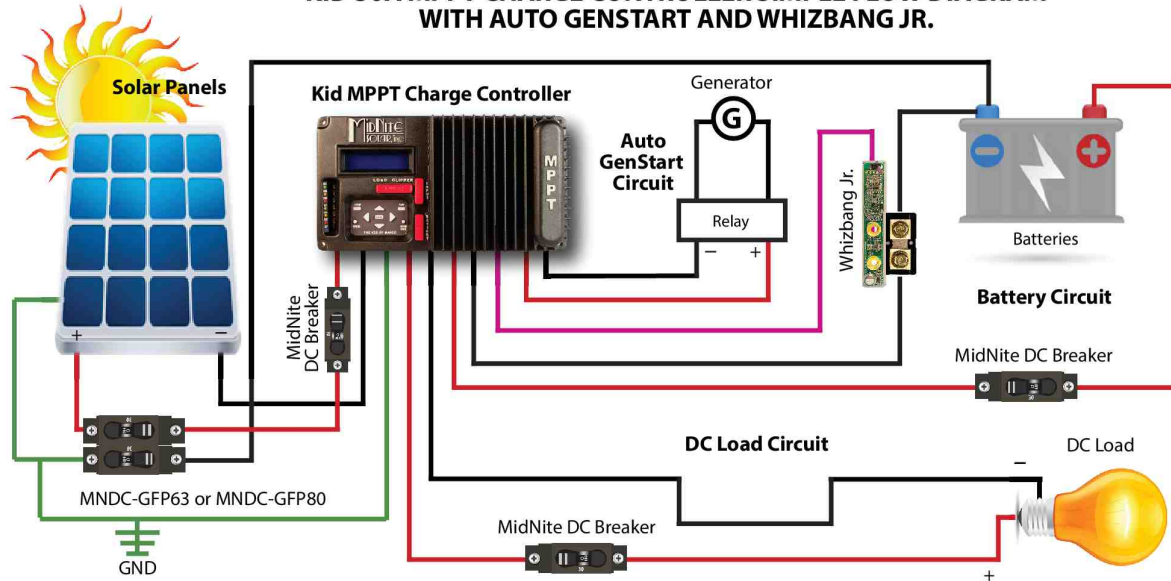

NOTE: This is not intended as a wiring diagram and is used only to display basic wiring concepts.

MidNite Solar Inc. 17722 - 67th Ave NE Arlington, WA 98223 PH. 360-403-7207  
[www.midnitesolar.com](http://www.midnitesolar.com)

**Auto Gen Start (AGS)** – This function will try to start the Generator and while monitoring battery voltage to assure the generator is charging. If not, it will signal the generator to shut down to conserve fuel.

**Generator On at:** Battery voltage level that will trigger the signal to start the generator.

**GenStart Delay:** Delay in minutes that the battery voltage must be below the “Generator On at” setting ,To signal the generator to start.

**MIN Gen Run Time:** Minimum time in minutes the generator will run after Auto Gen Start.

**MAX Gen Run Time:** Maximum time in minutes the generator will run after Auto Gen Start.

**Gen Run Confirm:** When battery voltage and time requirements for Auto Gen Start have been met, the Input mode will be turned off for a “Qualifying time” period. During this time the kid will look at the battery voltage to see if it has reached the Gen Run Confirm voltage. If successful the gen run signal will be kept on for at least the minimum run time. If this voltage is not reached then the run signal to the Generator will be turned off and a warning LED will be turned on. In either case the Input mode will be turned back on after the qualifying time period.





# The Kid Solar Charge Controller Instructions

---

## Setting up The Kid for use with a Whiz Bang Jr. (Sold separately)

### State Of Charge:

The Kid in conjunction with the Whiz-Bang JR. offer a real battery **State Of Charge** meter. There is some set-up before using the WB Jr. It is necessary to enter values for Battery bank size in Amp-Hours, battery efficiency, Battery temperature compensation reference, and percentage of change per degree C. Refer to the battery manufacturer's documentation for these values.

### To enable the WBJR on The Kid:

Press Main Menu button.

Scroll to the right, Until Aux is in shown in brackets, **<AUX>** Press Enter.

When the display shows FUNCTION: press the right or left key until WBJR is selected.

Press the Right button until the \* is next to Auto.

Press the SETUP button to setup the SOC portion.

### Entering battery bank information:

**Battery Capacity:** This is the first screen after you press the **SETUP** button, Battery Capacity can be obtained from your battery manufacturer, this is the total capacity of the battery bank.

Use the up and down buttons to adjust the battery capacity of the bank.

Press the Right button to go to the next set up.

### Battery Efficiency:

Batteries are not 100 percent efficient and some loss does occur. This setting will improve accuracy by taking this inefficiency into account. Battery efficiency will be different between Manufacturers and will lower with age, 94% is a good starting point for most battery banks. Your battery bank will reach 100% charge as soon as it hits float stage.

Use the up and down buttons to adjust the battery efficiency of the bank

Press the Right button to go to the next set up.

**Battery Temperature Reference:** This is a reference temperature used as a starting point for temperature based charging voltage adjustments. This is the temperature at which the battery manufacturer considers the temperature compensation to be zero, usually this will be 25°C, but it may vary by manufacturer and battery type.

Use the up and down buttons to adjust the battery temp ref of the bank.

Press the Right button to go to the next set up.

**Battery Change %:** the change of battery capacitance in percentage above and below of the temperature reference, usually will be 1%.

Use the up and down buttons to adjust the battery capacity change percentage.

Press the SAVE button to save the whole set up.

Press the Status button and then scroll to the right to view the WBJR SOC screen.

This screen will show you the Output current going straight to the batteries after the loads, also the SOC in percentage of the battery bank and also the Amp hours remaining on the batteries.



# The Kid Solar Charge Controller Instructions

## Password protected settings:

UL standards mandate that only qualified people be allowed to change critical settings. We have determined that people that have read and understood this much of the manual are qualified to change critical settings.

Changing some of the settings available on The Kid can result in hazardous conditions such as, battery charger, EQ, Temp Comp and load settings. If you do not fully understand these functions and features contact your dealer.

## Password:

Settings like Battery, input, load settings, calibration and Aux settings are password protected. When the password is entered it allows 10 min for the user to adjust protected settings.

Entering the password:

Press **Main Menu**,

Select **MISC** and press **Enter**,

Select **Password** and press **Enter**,

Select **Yes**.

When prompted, the Password is 142.

## LCD Power Saving modes:

There are 2 different LCD Power settings that can be chosen by the user, they function as follows:

**ECO:** Eco mode is the default mode. This mode will turn off the Backlight after 5 min of no user input on the keypad. Turning the backlight off helps reduce the idle power of the Kid by 1/3 of a watt. This mode will also return the menus to the Main Status menu after 5 minutes has elapsed.

**NRML:** Normal LCD mode keeps the Backlight Setting as set by the user, so if the Backlight is set to on the Backlight will stay on. The backlight draws 1/3 watt, so it isn't a big power drain to leave it on.

For any mode, idle time is set to 5 minutes. To turn the backlight back on, simply press any key and the LCD will come back on.

**Scrolling Status Screens:** When the Kid has no user input for 5 minutes the Screen will automatically go to the status Screen and scroll through all status screens one by one every 3 seconds or so. It was designed so it would not interfere with the user setting the unit parameters, but if this is not what you want your unit to do you can always disable this feature:

- Press Menu Back and scroll to the "MISC" menu and press Enter
- Select "LCD" and press Enter and Scroll to the right to select "Status Scroll?"
- Press the down key to Disable
- Scroll to the left and select the "LCD Power Mode"
- Press Save .

## Backlight/Contrast:

to adjust the backlight and contrast of the LCD, press the SETUP button in the LCD Power Savings Screen. Use the up and down buttons to adjust them.



# The Kid Solar Charge Controller Instructions

---

## **LED MODE:**

Located under the MISC menu, the LED mode can be set to several different modes, some useful and some just for fun.

**NRML:** this mode will employ all the available LEDs as indicators, The top 3 LEDs refer to the Battery Capacity Meter function on the kid that indicates to the user the current battery status at a glance (refer to BCM Section for more info). The FLT LED will come on when the unit goes to Float. It will blink Slowly when the unit goes to Float MPPT. This mode will also use the Warning (OVR) LED to indicate when there is an anomaly on the unit, such as Over Voltage or Current Limit. The ERR LED is also active to indicate Faults on the system. The CLP LED will come on when the Load is active and it will blink to indicate a warning on the load circuit.

**BCM:** The BCM function on the LEDs will only employ the top 3 BCM LEDs and the OVR and ERR LEDs.

**RICK:** this mode is also known as minimal LED usage, since it will only use the Warning and Error LEDs.

**PLAY:** this mode is great for special occasions where you want to Show off your Kid's fun side, it will trail the LEDs from top to bottom as long as this mode is selected.

**TEST:** Useful to verify that all the LEDs are functioning.

**OFF:** will keep the LEDs OFF, except for the ERROR LED.



# The Kid Solar Charge Controller Instructions

## Wiring Diagrams

12 Volt System with two solar panels in series

**Important!**  
Both the input and output negative must be connected.  
Failure to do so will cause inaccurate current readings and possible damage to the unit.

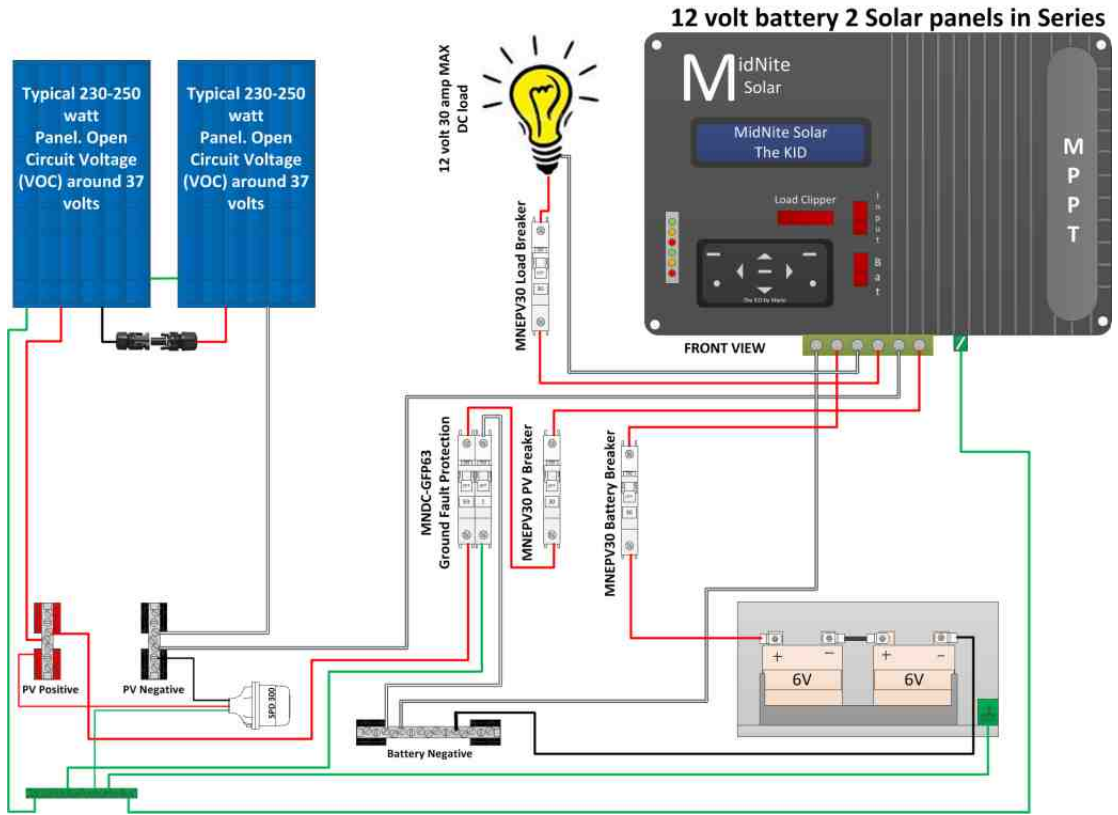

12 Volt System with two solar panels in parallel

**Important!**  
Both the input and output negative must be connected.  
Failure to do so will cause inaccurate current readings and possible damage to the unit.

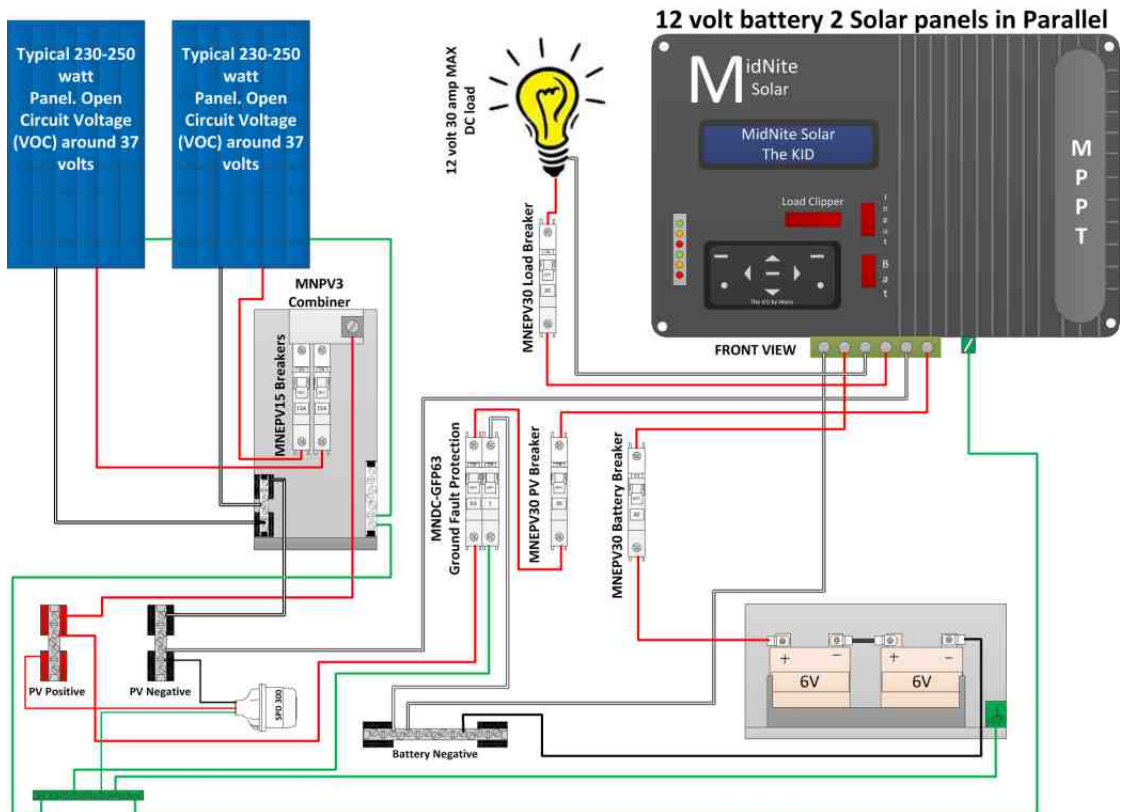



# The Kid Solar Charge Controller Instructions

24 Volt System with two solar panels in series

**Important!**  
Both the input and output negative must be connected.  
Failure to do so will cause inaccurate current readings and possible damage to the unit.

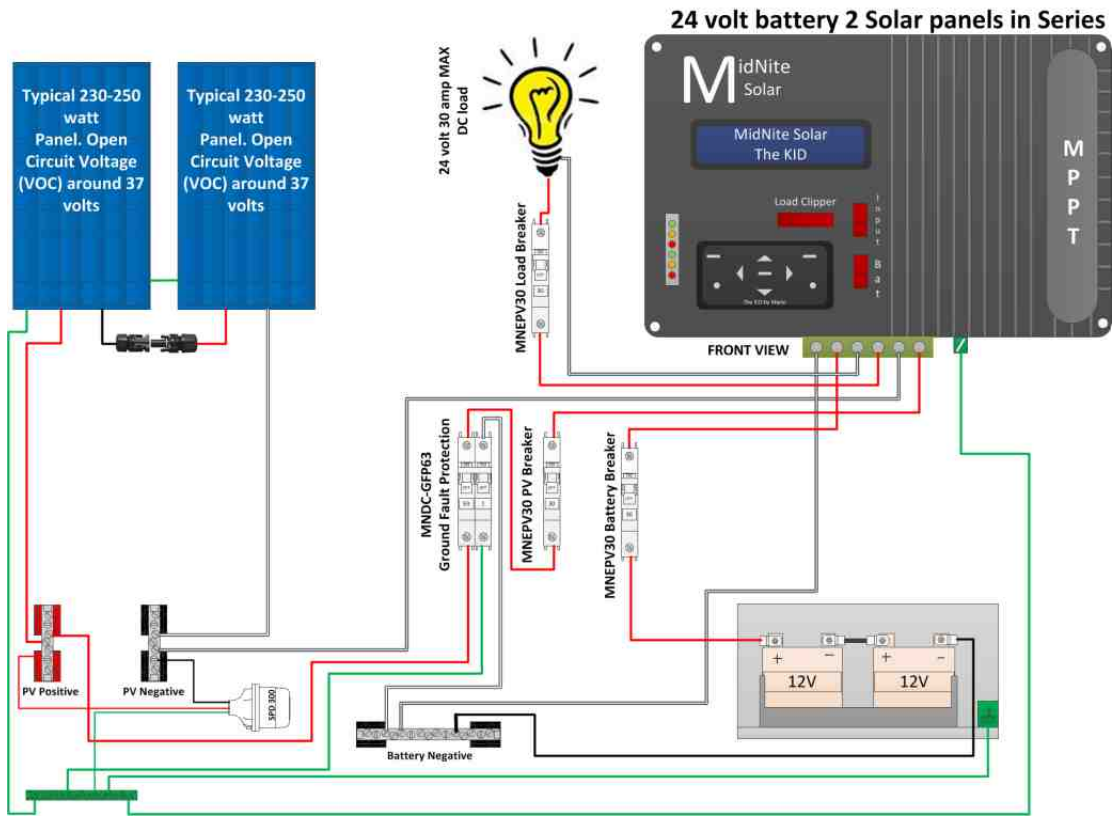

24 Volt System with three solar panels in Series

**Important!**  
Both the input and output negative must be connected.  
Failure to do so will cause inaccurate current readings and possible damage to the unit.

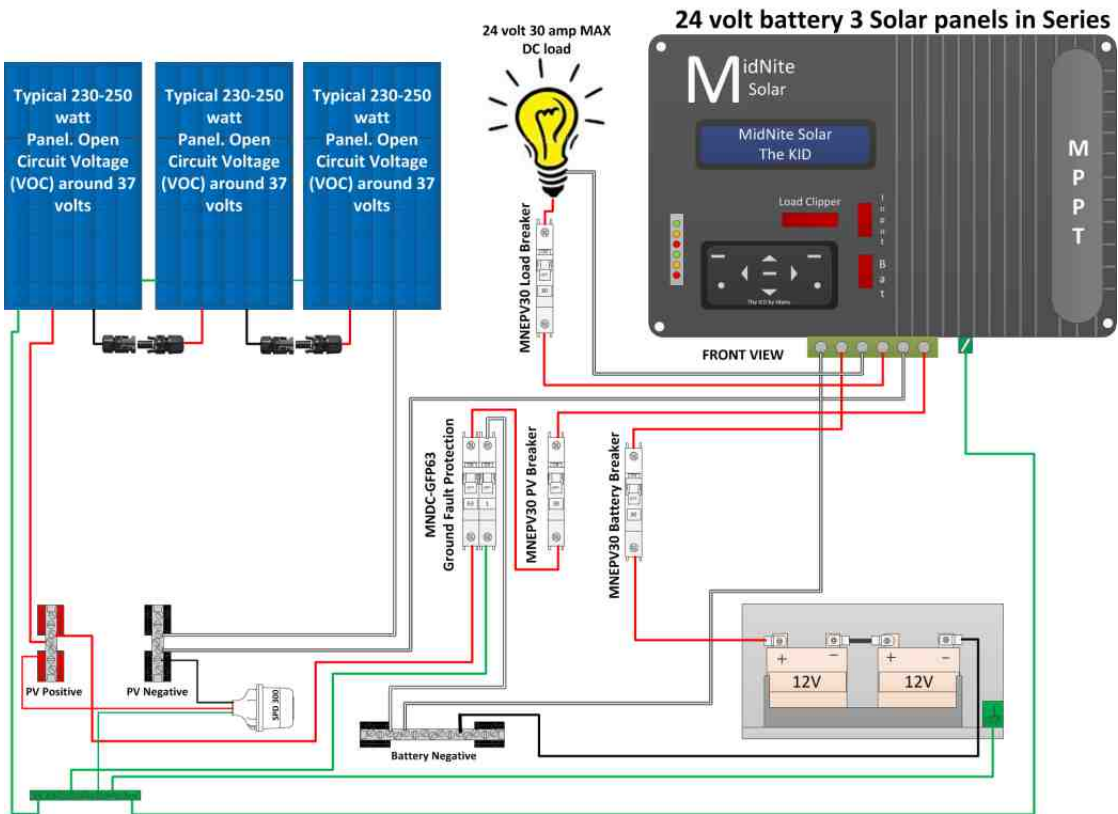



# The Kid Solar Charge Controller Instructions

24 Volt System with two strings of two panels

**Important!**  
Both the input and output negative must be connected. Failure to do so will cause inaccurate current readings and possible damage to the unit.

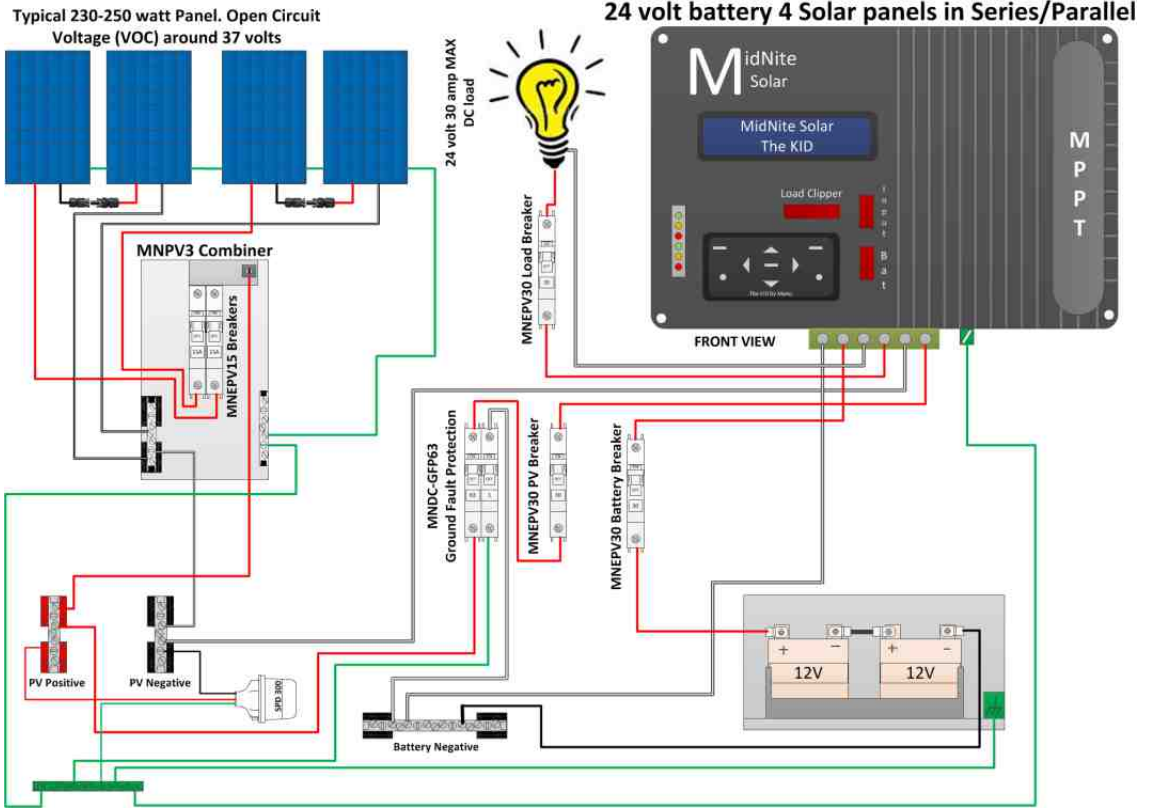

48 Volt System with three solar panels in series

**Important!**  
Both the input and output negative must be connected. Failure to do so will cause inaccurate current readings and possible damage to the unit.

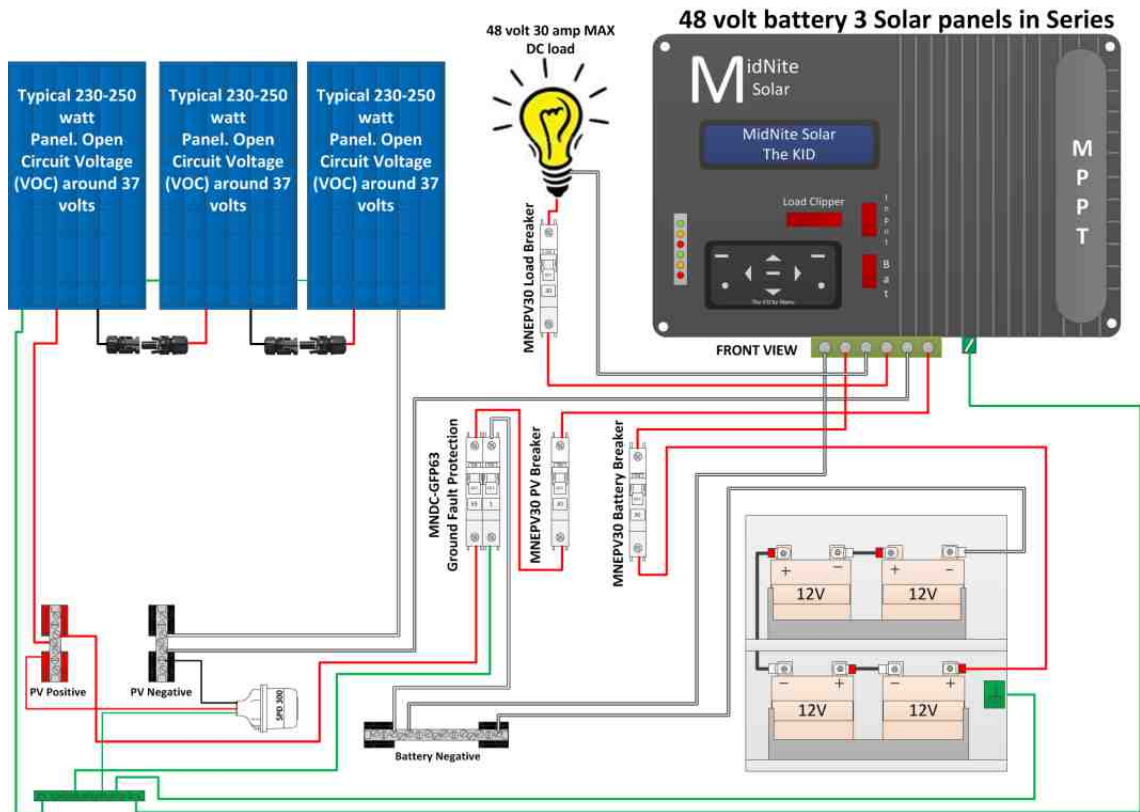



# The Kid Solar Charge Controller Instructions

48 Volt System with two strings of three panels

**Important!**  
Both the input and output negative must be connected.  
Failure to do so will cause inaccurate current readings and possible damage to the unit.

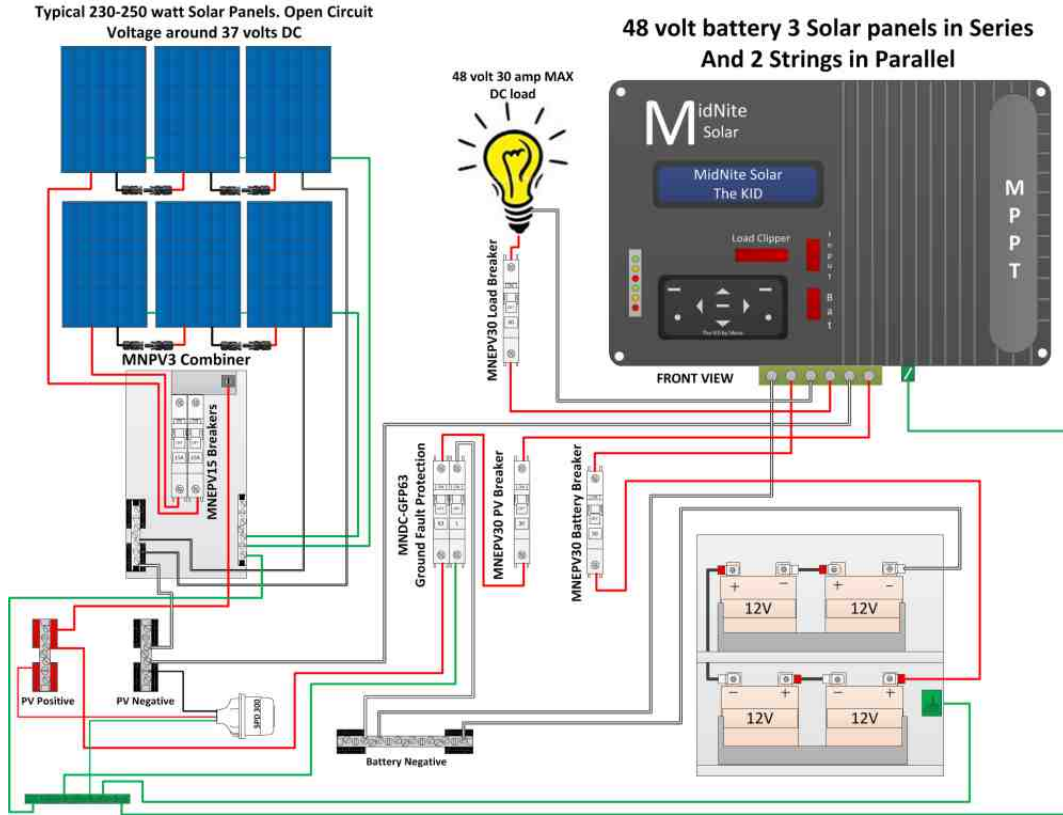

Two Kids paralleled with stacking cable

**Important!**  
Both the input and output negative must be connected.  
Failure to do so will cause inaccurate current readings and possible damage to the unit.

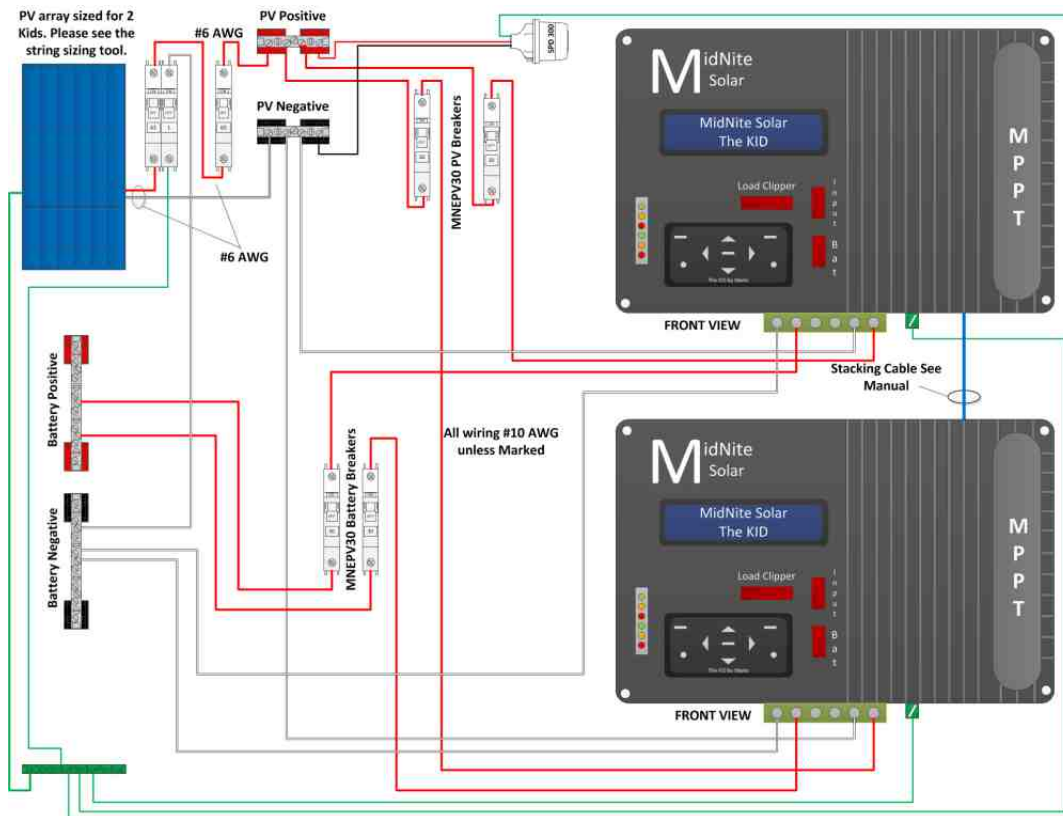

The string sizing tool is at [www.midnitesolar.com](http://www.midnitesolar.com)



# The Kid Solar Charge Controller Instructions

## HyperVOC

The Kid includes HyperVOC a non-operative VOC safety zone over and above the maximum input voltage



### Why do you need HyperVOC?

On cold mornings PV panels will put out full voltage even before you can see the sun. Ambient light may not have much current behind it but it does have voltage that may exceed the operating voltage limit of the controller, resulting in damage to the controller. The fact that there is no power behind the output voltage means that the controller will not be able to turn on and drag the panels down from VOC to max power voltage.

The controller requires a few watts of power coming in from the PV panels to overcome its internal power requirements. While the controller is waiting for enough power to wake up, the PV array is at its highest output voltage. This is very dangerous if the maximum operating voltage of the controller is exceeded.

The Kid Solar controller gives you bonus headroom for those cold mornings that would potentially destroy any other controller. We have advised thousands of customers to play it safe in conditions like our example above. MidNite has a unique characteristic of the circuitry that allows it to go beyond the maximum operating voltage for these conditions, it's called HyperVOC.

Do not abuse the HyperVOC zone though. For example, let's take a Kid configured with 4 modules in series that have 36.9 VOC,  $4 \times 36.9 = 147.6$ . In Alberta with a  $-32^{\circ}\text{C}$  temperature, the max VOC will reach 181.54. This is well within the HyperVOC zone on a 48V battery bank.

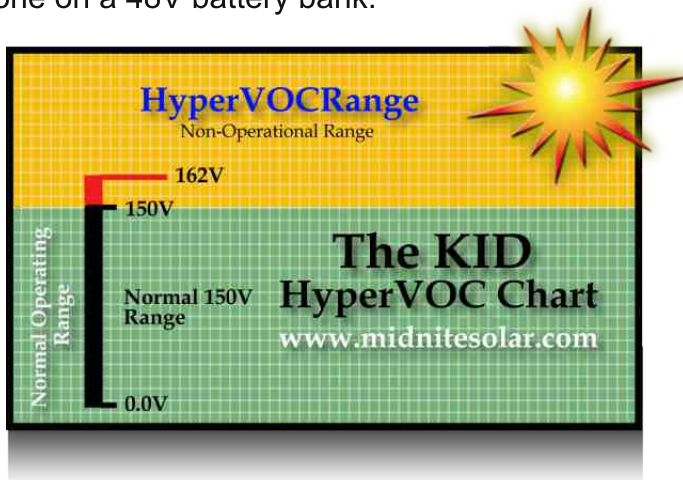

**Above:** HyperVOC voltage limits above normal operating voltage.

**Right:** Solar Panel VOC adjustments by temperature.

**Table 690.7** Voltage Correction Factors for Crystalline and Multicrystalline Silicon Modules

Correction Factors for Ambient Temperatures Below 25°C (77°F). (Multiply the rated open circuit voltage by the appropriate correction factor shown below.)

Ambient Temp (°C)	Factor	Ambient Temp (°F)
24 to 20	1.02	76 to 68
19 to 15	1.04	67 to 59
14 to 10	1.06	58 to 50
9 to 5	1.08	49 to 41
4 to 0	1.10	40 to 32
-1 to -5	1.12	31 to 23
-6 to -10	1.14	22 to 14
-11 to -15	1.16	13 to 5
-16 to -20	1.18	4 to -4
-21 to -25	1.20	-5 to -13
-26 to -30	1.21	-14 to -22
-31 to -35	1.23	-23 to 31
-36 to -40	1.25	-32 to -40





# The Kid Solar Charge Controller Instructions

### Kid Power Graph

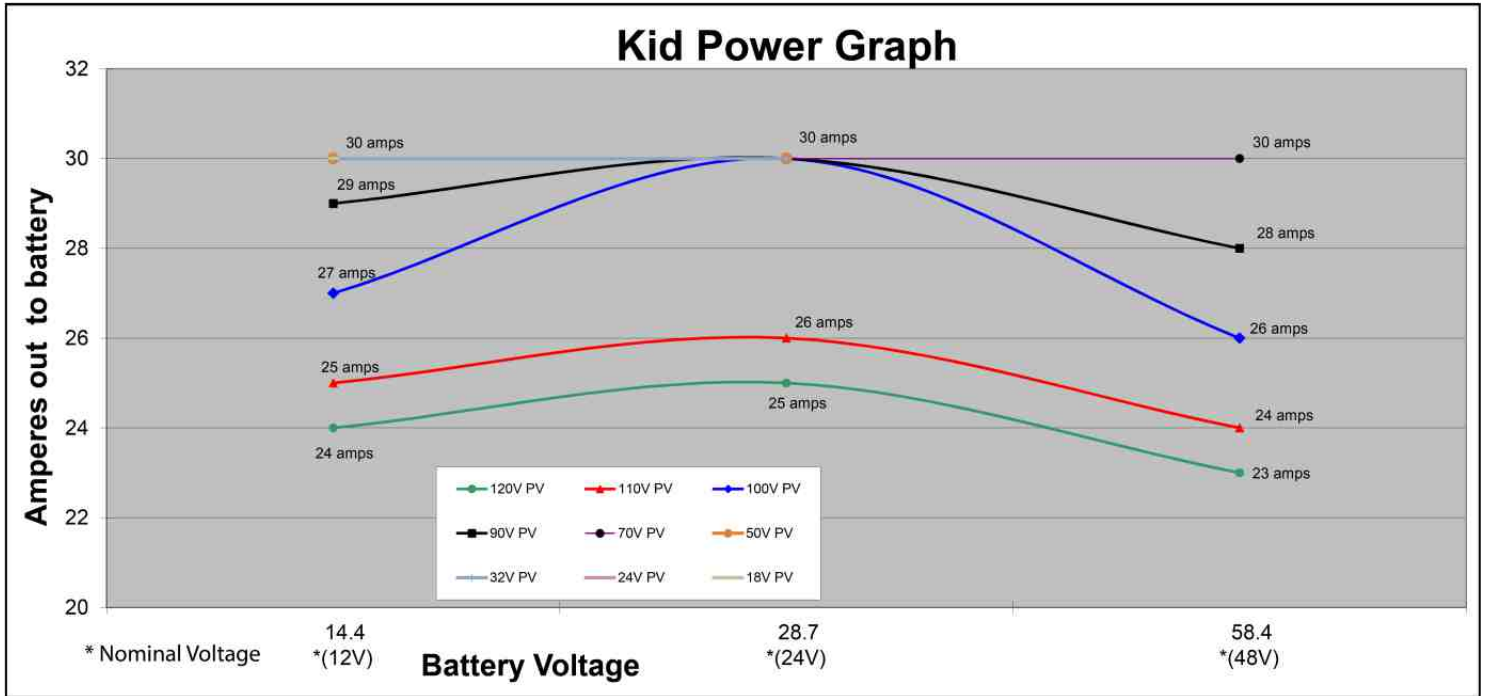

**PV Voltage levels shown are *maximum* values.**  
 VOC will be 20% higher.

## Accessories

Below are optional accessories and accessory kits.



### MNKID-BREAKER-30A

30 Amp replacement circuit breaker for The Kid.



# The Kid Solar Charge Controller Instructions

## Accessories Continued



### **MNKID-ASSY-KIT-B (Black) or MNKID-ASSY-KIT-W (White) Accessory kit**

Kit includes:

Black or white mounting bracket

Flexible conduit

Straight and 90° Conduit fittings

MNBTS Battery temperature sensor

Hardware to attach mounting bracket to The Kid



### **MNKID-WMB-B (Black) or MNKID-WMB-W (White) Wall Mount kit**

Kit includes:

Black wall mounting bracket

Hardware to attach mounting bracket to The Kid.



# The Kid Solar Charge Controller Instructions

## Accessories Continued



### MNHydrometer

Easy to use battery hydrometer for checking the specific gravity on all "Flooded" style batteries.  
Size: 5.25"L x 4.25"W x 1.5"D



### MNBCM / MNBCMS: Battery Status Monitor

1. LEDs that correspond to battery voltage
2. Voltage accuracy +/- .05%
3. Auto sensing for 12, 24, 36, and 48 volt batteries
4. LED indicators show if batteries have received a full charge recently, longer than one week or longer than two weeks
5. Ideal for "at a glance" readings - golf carts, forklifts, etc.

Description: Battery Capacity Meter

Size 4.5"L x 3.75"W x 1"D

Box Size 5"L x 4"W x 2"D

Weight 1 Lb.



# The Kid Solar Charge Controller Instructions

## Accessories Continued

### Whiz Bang Jr.:

The Whiz Bang Jr. is designed to work with The Kid to give accurate battery status. The Whiz Bang Jr. keeps track of Amp-Hours going into and out of the battery. Simple one-wire installation. Shunt not included.

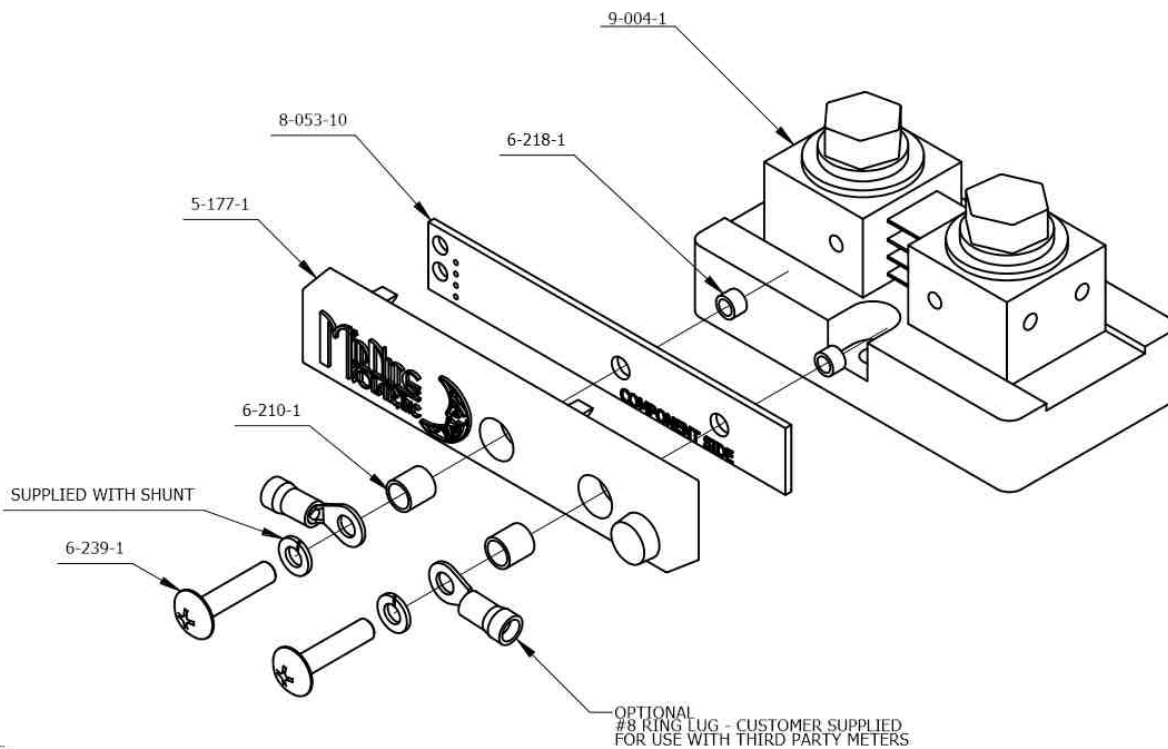
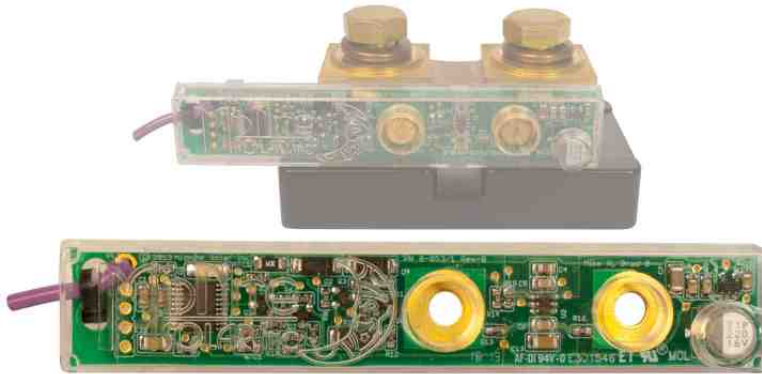

NOTE:  
THE WHIZ BANG JUNIOR CAN BE INSTALLED  
UPSIDE DOWN WITHOUT DAMAGE HOWEVER  
ALL READINGS WILL SHOW OPPOSITE POLARITY

The Whiz Bang Jr can also provide shunt access for co-operative products.



# The Kid Solar Charge Controller Instructions

## Optional Circuit Breakers and Accessories



### Big Baby

The Big Baby is an aluminum powder coated breaker enclosure that holds four DINRail breakers.



### Quad

The Quad is an aluminum powder coated breaker enclosure that holds four panel mount breakers.

More circuit breakers and accessories available at [www.midnitesolar.com](http://www.midnitesolar.com)



63 amp 150VDC din rail mount DC ground fault protector (NRTL listed breaker assy).

NEC2008 requires DC-GFP's on all solar installations

### MNDCGFP-63



### MNEPV Breaker

150VDC din rail mount breaker (13mm wide). MNEPV evaluated by ETL to 150VDC. 150VDC ETL listed in the US and Canada 10,000 AIC.



### MNEDC Breaker

DC Panel mount breaker available up to 100 amps.



### MNEAC Breaker

120V AC DINrail breaker available in a wide range of Amperages.



# The Kid Solar Charge Controller Instructions

## Warranty

### MIDNITE SOLAR INC. LIMITED WARRANTY

MidNite Solar Power electronics, sheet metal enclosures and accessories

MidNite Solar Inc. warrants to the original customer that its products shall be free from defects in materials and workmanship. This warranty will be valid for a period of five (5) years for all products unless otherwise specified. The MNKID Charge Controller is warranted for two (2) years.

At its option, MidNite Solar will repair or replace at no charge any MidNite product that proves to be defective within such warranty period. This warranty shall not apply if the MidNite Solar product has been damaged by unreasonable use, accident, negligence, service or modification by anyone other than MidNite Solar, or by any other causes unrelated to materials and workmanship. The original consumer purchaser must retain original purchase receipt for proof of purchase as a condition precedent to warranty coverage. To receive in-warranty service, the defective product must be received no later than two (2) weeks after the end of the warranty period. The product must be accompanied by proof of purchase and Return Authorization (RA) number issued by MidNite Solar. For an RMA number contact MidNite Solar Inc., 17722 67th Ave NE, Arlington, WA 98223 (360) 403-7207.

Purchasers must prepay all delivery costs or shipping charges to return any defective MidNite Solar product under this warranty policy. Except for the warranty that the products are made in accordance with, the specifications therefore supplied or agreed to by customer:

MIDNITE SOLAR MAKES NO WARRANTY EXPRESSED OR IMPLIED, AND ANY IMPLIED WARRANTY OF MERCHANTABILITY OR FITNESS FOR A PARTICULAR PURPOSE WHICH EXCEEDS THE FOREGOING WARRANTY IS HEREBY DISCLAIMED BY MIDNITE SOLAR AND EXCLUDED FROM ANY AGREEMENT MADE BY ACCEPTANCE OF ANY ORDER PURSUANT TO THIS QUOTATION. MIDNITE SOLAR WILL NOT BE LIABLE FOR ANY CONSEQUENTIAL DAMAGES, LOSS OR EXPENSE ARISING IN CONNECTION WITH THE USE OF OR THE INABILITY TO USE ITS GOODS FOR ANY PURPOSE WHATSOEVER. MIDNITE SOLAR'S MAXIMUM LIABILITY SHALL NOT IN ANY CASE EXCEED THE CONTRACT PRICE FOR THE GOODS CLAIMED TO BE DEFECTIVE OR UNSUITABLE.

Products will be considered accepted by customer unless written notice to the contrary is given to MidNite Solar within ten (10) days of such delivery to customer. MIDNITE SOLAR is not responsible for loss or damage to products owned by customer and located on MIDNITE SOLAR'S premises caused by fire or other casualties beyond MIDNITE SOLAR'S control. This warranty is in lieu of all other warranties expressed or implied.

MIDNITE SOLAR INC. 17722 67TH AVE NE ARLINGTON, WA 98223

Email:

info@midnitesolar.com

PH: 360-403-7207 FAX: 360-691-6862



# The Kid Solar Charge Controller Instructions

MIDNITE SOLAR INC.

## THE KID MIDNITE MPPT CHARGE CONTROLLERS



### PRODUCT SPECIFICATIONS

Operating Input Voltage	150VDC
Nominal Battery Voltage	12V through 48V
Maximum Output Current	30A
PV Open Circuit Voltage VOC	150VDC + HyperVOC (162VOC)
HyperVOC (See page bottom)	Extended VOC range for cold climates
Charging Regulation	Bulk, Absorb, Float as well as Equalization
Battery Voltage Range	9V TO 64V
Equalization Charging	Adjustable Voltage and Duration, Manual or Auto
Battery Temp Compensation (Standard marine version - optional otherwise)	Automatic when BTS is installed, Adjustable mV per degree C per 2 volt cell
Programmable Auxiliary Control Output	1 - I/O Aux communication or with Wizbang Jr.
Status Display	LCD plus status LED
Networking Cabling	Standard 4 conductor phone cable, no hub needed
Communications	RS232 openly published protocols and USB
Load Terminal	30A configurable as battery load or wind clipper
Solar, Wind And Hydro Applications	Standard
Operating Temperature	Min. of -40C to 50C - Controller will auto derate as temperature rises above 25C
Environmental Rating	Indoor IP64 type 1
Conduit knock Outs	2
Warranty	2 Year
Lighting Controller	Highly customizable via keypad (dusk-dawn, hourly, day, night, etc).
Weight	6 Lbs.
Dimensions	9 1/4"L x 5"H x 3 5/16"W (23.5CM x 12.7CM x 8.4CM)
Shipping Dimensions	12"L x 8"H x 6"W (30.48CM x 20.32CM x 15.24CM)
Options	3ft. network cable, external load, boat mount bracket
Certifications	ETL for US & Canada,
True Paralleling	Inputs and Outputs between 2 units with smart active current sharing
Battery Types	Flooded, AGM, Gel, Calcium SMF, Lithium BMS, Custom

*HyperVOC: A non-operative VOC safety zone over and above the maximum input voltage for cold climates.*

www.midnitesolar.com  
17722 67th Ave. NE., Arlington, WA. 360-403-7207 FAX: 360-691-6862





# The Kid Solar Charge Controller Instructions

## Ratings

Max Input Voltage PV-----	162 VDC Non-Operating
Max Operating input Voltage PV-----	150 VDC
Max Input Current PV-----	30 Amps DC
Max Output Current-----	30 Amps @ 25°C*
Max Input Short Circuit Current-----	30 Amps DC
Max Output source Backfeed-----	30 Amps DC
DC Output Voltage-----	12-64 VDC
Input Battery Voltage-----	12, 24 or 48 VDC
Input Battery Voltage Range-----	9-64 VDC
Operating Temperature Range-----	-40°C° to 50°C

\*Derated to 20 Amps @ 40°C.

Fuses / Overcurrent protection.

Replace fuses with the same type and ratings: Type ATC 32V 30 Amps Max.

The fuses provided in The Kid are for supplemental protection. External overcurrent protection is required as part of the installation.





# The Kid Solar Charge Controller Instructions

**MIDNITE SOLAR INC. - KID MENU MAP**    **May 1, 2015**    **REV: v1797**

**QUICK START SETUP**

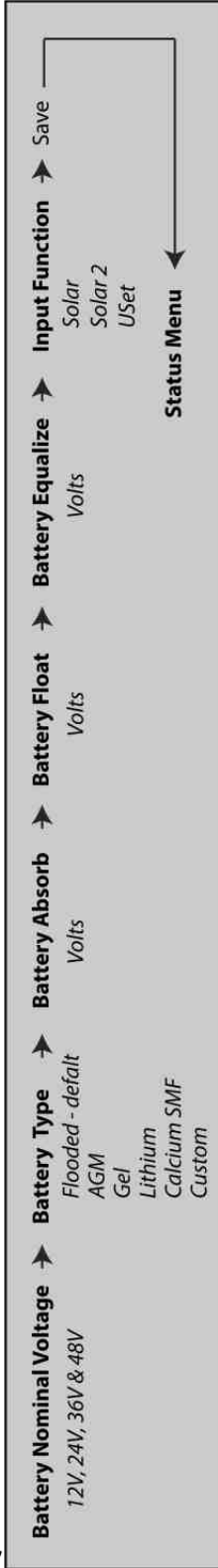

**BATTERY MENU - Adjust Setpoints**

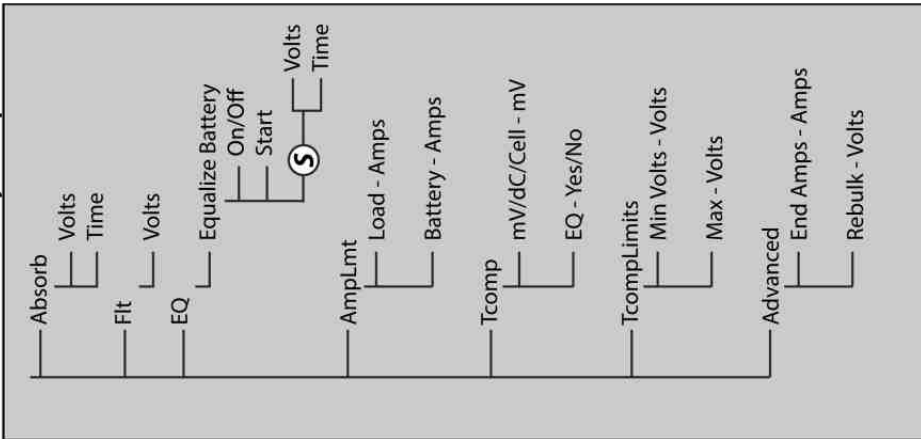

**LOAD MENU - Set Load/Clipper**

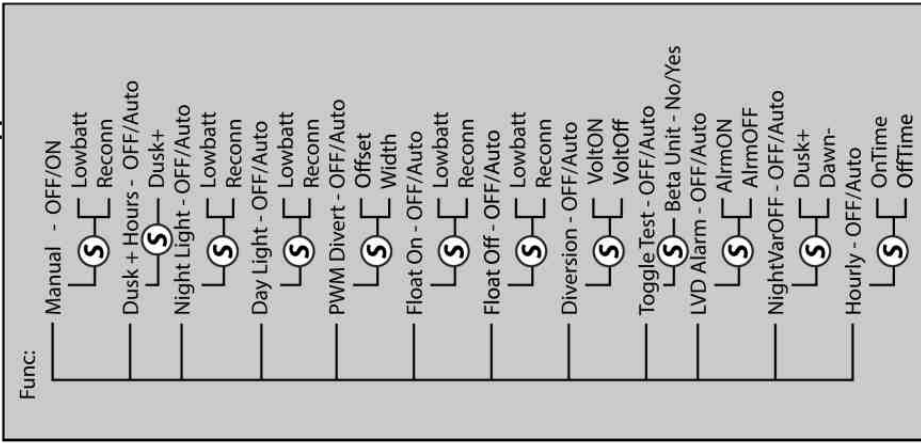

**INPUT MENU - Adjust MPPT Mode**

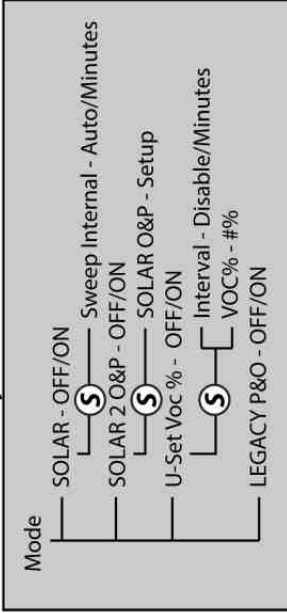

**AUX MENU - Setup Aux Func**

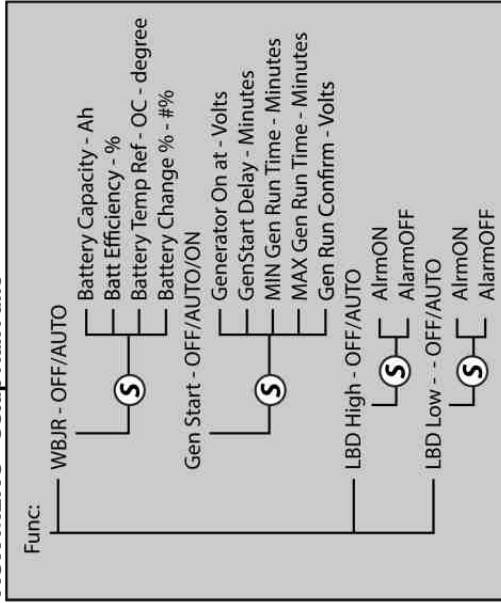

**www.midnitesolar.com**  
**17722 - 67th Ave NE, Arlington, WA 98223**  
**PH 360-403-7207 FAX 360-691-6862**

Ⓢ Symbolizes the SETUP button being pushed.



# The Kid Solar Charge Controller Instructions

## TECH MENU - Advanced Menu

Calibration  
 Battery V OFFSET - Volts  
 Input V OFFSET - Volts  
 AntiClick Sensit  
 EndAmp Shunt Sel UP/DOWN - KID/WBJR  
 Pre Matching  
 Min Low Power  
 NightLight on PV - Profile #  
 NightLight VOC%  
 Factory Reset  
 Press and Hold Left and Right  
 Updates Firmware  
 BOOTLOADER xx FIRMWARE UPDATE  
 About Kid CC  
 BOOTLOADER xx FIRMWARE xxxx

### KID NAVIGATION PANEL

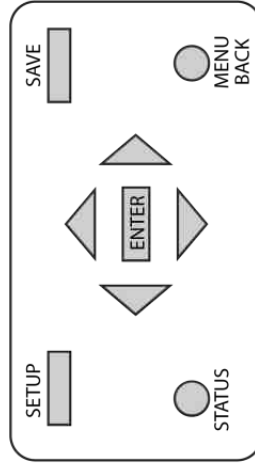

## COMM MENU - Multiple Units

Communicate Mode  
 Twin - KID Search  
 Sync  
 PC - KID PC Mode

### SETUP

Displays the adjustable parameters of the specific function selected.

### SAVE

Saves all the modified functions and parameters.

### ENTER

Enters the selected menu item.

### STATUS

Displays the current Status of the Kid. Press once to go back to the previous status screen, press twice to go to main status.

### MENU/BACK

When pressed from Status Menu, it will go to Main Menu. If inside a menu it is used to go back one menu.

### UP, DOWN, LEFT & RIGHT ARROWS

Used to navigate the menus, select and modify the functions.

Ⓢ Symbolizes the SETUP button being pushed.

## MISC MENU - Other Stuff

LCD  
 LCD Power Mode  
 ECO  
 Ⓢ ADJUST UP/DOWN  
 BKLite  
 CONTRAST  
 NORMAL  
 STATUS SCROLL? - ENABLE/DISABLE  
 TEMP  
 CPU - C  
 FET - C  
 BATT  
 LEDS - LED MODE  
 NRML  
 BCM  
 RICK  
 PLAY  
 TEST  
 OFF  
 TIMER: TIME - 00:00:00  
 PASSWORD  
 PASSWORD ENABLE - NO/YES

## STATUS MENU

Screen 1  
 Battery Output Current  
 Bulk MPPT - State Of Charger  
 Battery Voltage  
 Charger Mode (Solar)  
 Wattage Into Battery  
 Screen 2  
 Input - PV Array Voltage  
 Battery - Battery Voltage  
 Screen 3  
 WBJR Amps  
 Shunt  
 Screen 4  
 Load: Function  
 Screen 5  
 KWhr  
 Ahr

Pushing the right/left arrow button will cycle through the Status Menu screens.

[www.midnitesolar.com](http://www.midnitesolar.com)  
 17722 - 67th Ave NE, Arlington, WA 98223  
 PH 360-403-7207 FAX 360-691-6862



# The Kid Solar Charge Controller Instructions

## Glossary

Absorb	A charging state where the battery is held at the absorb volt setting for a time set by the user.
Amp.....	A measurement of electrical current.
Amp-Hour.....	A measurement of electrical power. Amps x Hours.
AWG.....	American Wire Gauge.
BATT.....	Battery or Battery Bank.
Bulk.....	A charging state where all available power goes to the battery until it reaches the Absorb voltage setting.
EMI.....	Electro Magnetic Interference. Electrical noise.
EQ.....	Equalization charge. An extended charge to match charge level on battery cells.
Float.....	A charging state to maintain a fully charged battery.
LED.....	Light Emitting Diode.
LVD.....	Low Voltage Disconnect.
OVD.....	Over Voltage Disconnect.
MPPT	Maximum Power Point Tracking. Adjusts loading on the panels for optimum power yield. The Kid employs MPPT.
Minus.....	Negative battery or PV connection or Negative load connection
Parallel	A mode where additional Kid(s) may be connected to increase The Kid's charging capacity.
Plus.....	Positive power connection.
PV.....	PhotoVoltaic.
PWM.....	Pulse Width Modulation. How some charge controllers maintain regulation.
Solar Clock.....	The ability of The Kid to estimate time of day. Used with the load function.
Temp Comp	An automatic adjustment made to the charging voltage based on battery temperature.
Three Stage Charging.....	A charging scheme for batteries with three levels of charging.
Watt.....	Instantaneous power. Amps x Volts = Watts.
Watt-Hour.....	A measurement of electrical power. Watts x Hours = Watt-Hours.



# The Kid Solar Charge Controller Instructions

## Wall Mounting Template

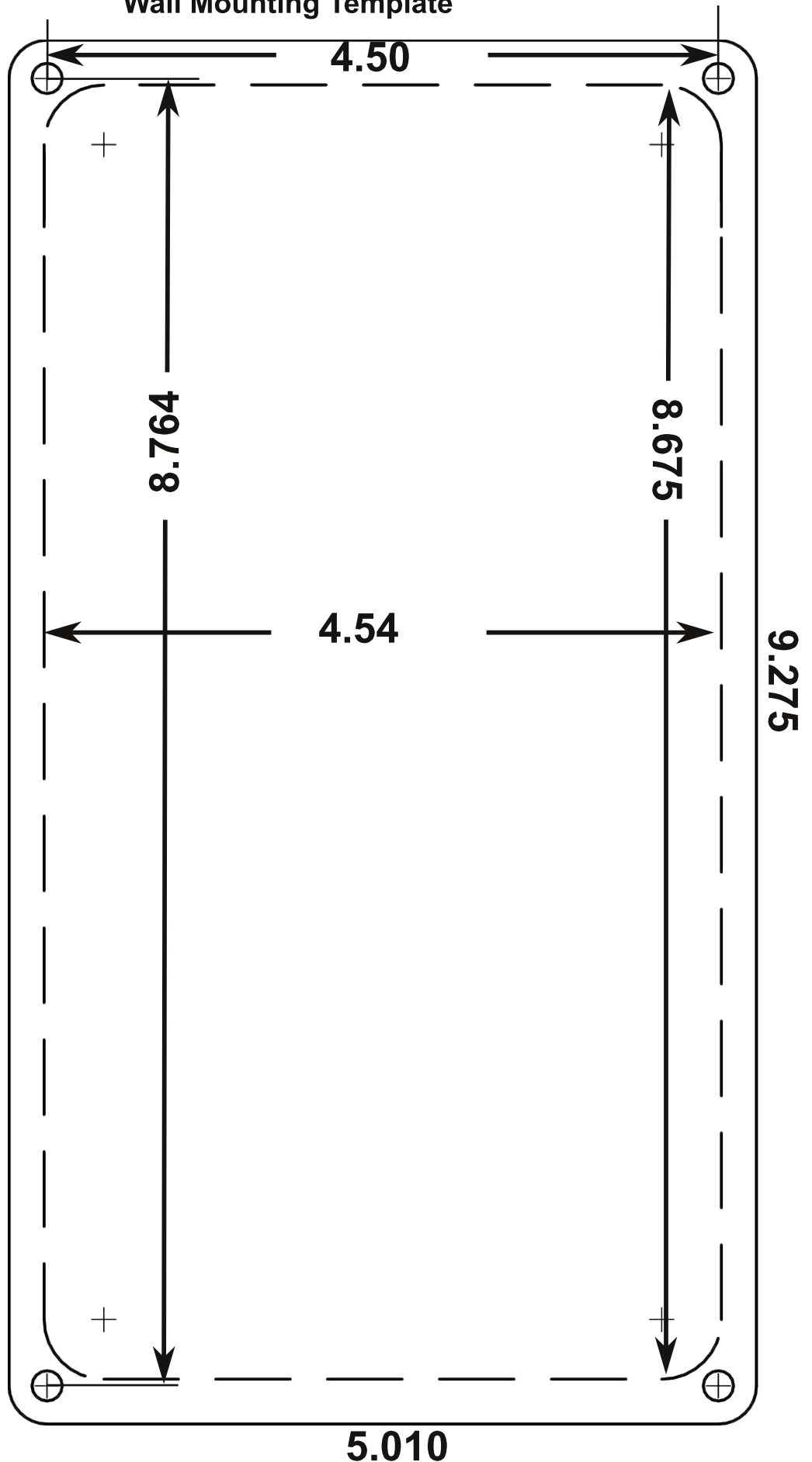

### To use this template:

- Remove template from the manual and secure to the wall with a low tack tape such as scotch or masking tape.
- Other tapes are more likely to stick to the paint when they are removed. Remove all tape within 24 hours.
- Make sure that the template is flat and not crooked.
- Use a large drill inside the cut-out area to create an entry point for the saw. Use a drywall or jig saw and cut along the dotted lines using caution especially around the corners. A hole saw may be used in the inside corners.
- Drill the four corner holes with the smallest drill that will work with your hardware. Use caution to avoid breaking through to the large cut-out area.
- Put The Kid in place and secure with appropriate hardware.
- Photocopies of the template may not be accurate and should be avoided.