



## Mini Magnum Panel (MMP)



Owner's Manual

## **Disclaimer of Liability**

Since the use of this manual and the conditions or methods of installation, operation, use and maintenance of the MMP enclosure (Mini Magnum Panel) is beyond the control of Magnum Energy, Inc., this company does not assume responsibility and expressly disclaims liability for loss, damage or expense, whether direct, indirect, consequential or incidental, arising out of or anyway connected with such installation, operation, use, or maintenance.

Note as well that while every precaution has been taken to ensure the accuracy of the contents of this manual, the specifications and product functionality may change without notice. Magnum Energy, Inc. assumes no responsibility for errors or omissions.

## **Restrictions on Use**

The MMP enclosure may only be used in life-support devices or systems with the express written approval of Magnum Energy. Failure of the MMP enclosure can reasonably be expected to cause failure of that life-support device or system, or to affect the safety or effectiveness of that device or system. If the MMP fails, it is reasonable to assume the health of the user or other persons may be endangered.

## **Copyright Notice**

Copyright © 2013 by Magnum Energy, Inc. All rights reserved. Permission to copy, distribute, and/or modify this document is prohibited without express written permission from Magnum Energy, Inc.

## **Document Information**

Description – Mini Magnum Panel (MMP) Owner’s Manual

Part Number and Revision – 64-0029 Rev D

Date Published – June 2013

This manual is printed without color for cost savings. However, this entire manual is available for download under the Document Library tab at [www.magnumenergy.com](http://www.magnumenergy.com) with many of the diagrams available in color.

## **Contact Information**

Magnum Energy, Inc.

2211 West Casino Rd.

Everett, WA 98204

Phone: 425-353-8833

Fax: 425-353-8390

Web: [www.magnumenergy.com](http://www.magnumenergy.com)

## **Statement of Appreciation**

From all of us at Magnum Energy –

Thank you for purchasing this Mini Magnum Panel (MMP).

We understand that you have many purchasing options in the marketplace, and are pleased that you have decided on a Magnum Energy product. This MMP enclosure was proudly assembled and tested in the United States in our Everett, Washington, facility.

At Magnum, we are committed to providing you with quality products and services, and hope that your experience with us is pleasant and professional.

Magnum Energy® is a registered trademark of Magnum Energy, Inc.

# IMPORTANT SAFETY INSTRUCTIONS

## SAVE THESE INSTRUCTIONS

THIS MANUAL CONTAINS IMPORTANT INSTRUCTIONS FOR THE MMP ENCLOSURE THAT SHALL BE FOLLOWED DURING THE INSTALLATION AND OPERATION OF THIS PRODUCT. Before using the MMP, read all instructions and cautionary markings. Also, be sure to review the individual manuals provided for each component of the system. The installation instructions are for use by qualified personnel only. Do not perform any installation or servicing other than that specified in this owner's manual unless you are qualified to do so. Incorrect installation or servicing may result in a risk of electric shock, fire, or other safety hazard.

### Safety Symbols

The following safety symbols have been placed throughout this manual to indicate dangerous and important safety instructions.



**WARNING:** This symbol indicates that failure to take a specified action could result in physical harm to the user.



**CAUTION:** This symbol indicates that failure to take a specified action could result in damage to the equipment.



**Info:** This symbol indicates information that emphasizes or supplements important points of the main text.

### Safety Precautions

- All electrical work must be performed in accordance with local and national electrical codes.
- This product is designed for indoor/compartment installation. It must not be exposed to rain, snow, moisture, or liquids of any type.
- Use insulated tools to reduce the chance of electrical shock or accidental short circuits.
- There are no user-serviceable parts contained in this product.
- This unit is provided with integral protection against overloads.
- Live power may be present at more than one point since an inverter utilizes both DC (batteries, PV, etc.,) and AC (utility or generator) power. To reduce risk of electric shock, ensure all DC and AC wiring is disconnected prior to installing or performing maintenance on the inverter. Turning off the inverter will not reduce this risk, the inverter must be totally disconnected from all sources.
- Use Class 1 wiring methods for field wiring connections to terminals of a Class 2 circuit.
- Listed or labeled equipment shall be installed and used in accordance with any instructions included in the listing or labeling.
- Always verify proper wiring prior to starting the inverter.
- Use only copper wires with a minimum temperature rating of 90°C.
- AC wiring must be no less than 10 AWG (5.3 mm<sup>2</sup>) gauge copper wire.
- Battery cables should be no less than #4/0 AWG for 12 and 24-volt systems and #2/0 AWG gauge for 48-volt systems. Crimped and sealed copper ring terminal lugs with a 5/16 hole should be used to connect to the DC terminals on the inverter.
- Torque all AC wiring connections and DC cable connections to the required torque values.
- Overcurrent protection of the battery cables must be provided as part of the system installation.
- Overcurrent protection of the AC output wiring must be provided as part of the system installation.

- The AC output neutral conductor and the DC negative conductors are not connected (bonded) to the inverter chassis. Both the input and output conductors are isolated from the enclosure and each other. System grounding, if required, is the responsibility of the system installer and must comply with local and national electrical codes and standards. Refer to the Section 2.10 “MMP/Inverter System Grounding” for more information.

### Battery Safety

- Use insulated tools and be very careful when working around batteries, they can produce extremely high currents if short-circuited (e.g., dropping a metal tool across the battery terminal), which could cause a fire or explosion.
- Read and follow the battery manufacturer’s safety precautions before installing the inverter and batteries. Always verify proper polarity and voltage before connecting the batteries to the inverter. Once the batteries are connected to the inverter, ensure the maintenance and charging requirements (i.e., charge voltage and charge rate) provided by the battery manufacturer are followed to extend the life of the batteries and to prevent damage to the batteries while charging.
- Wear eye protection such as safety glasses, and avoid touching your eyes and face when working with batteries to keep any fluid/corrosion on the battery from coming in contact with eyes and skin. Have plenty of fresh water and soap nearby and thoroughly wash in case battery acid contacts skin, clothing, or eyes. In the event of exposure to the eyes, flood them for at least 15 minutes with running water and seek immediate medical attention. Baking soda neutralizes lead acid battery electrolyte and vinegar neutralizes spilled NiCad and NiFe battery electrolyte; depending on your battery type, keep a supply on hand near the batteries.
- Remove all jewelry such as rings, watches, bracelets, etc., when installing or performing maintenance on the batteries and inverter. A battery can produce a short-circuit current high enough to weld metal jewelry, causing severe burns.
- Never work alone. Always have someone within the range of your voice or close enough to come to your aid when working around batteries.
- Use proper lifting techniques when working with batteries.
- Never use old or untested batteries. Check each battery’s label for age, type, and date code to ensure all batteries are identical.
- Batteries are sensitive to changes in temperature. Always install batteries in a stable environment.
- Batteries can produce explosive gasses, so install batteries in a well-ventilated area. For compartment or enclosure installations, always vent batteries from the highest point to the outside. Design the battery enclosure to prevent accumulation and concentration of hydrogen gas in “pockets” at the top of the compartment.
- Provide at least one inch of air space between batteries to provide optimum cooling.
- Never smoke or allow a spark near batteries.
- To prevent a spark at the battery and reduce the chance of explosion, always connect the cables to the batteries first. Then connect the cables to the inverter.
- Never charge a frozen battery.

# CONSIGNES DE SÉCURITÉ IMPORTANTES

## CONSERVER CES INSTRUCTIONS

CE MANUEL CONTIENT DE IMPORTANTES POUR LA CLÔTURE DE MMP QUI DOIVENT ÊTRE SUIVIES PENDANT L'INSTALLATION ET FONCTIONNEMENT DE CE PRODUIT. Avant d'utiliser la série MS, lire toutes les instructions et les mises en garde. Aussi, n'oubliez pas de passer en revue les différents manuels fournis pour chaque composant du système. Les instructions d'installation sont pour une utilisation par du personnel qualifié. Ne pas effectuer une installation ou d'entretien autres que ceux spécifiés dans ce manuel, sauf si vous êtes qualifié pour le faire. Une mauvaise installation ou d'entretien peut entraîner un risque de choc électrique, un incendie ou autre danger pour la sécurité.

### Symboles de sécurité

Les symboles de sécurité suivants ont été placés tout au long de ce manuel pour indiquer des conditions dangereuses et les consignes de sécurité importantes.



**AVERTISSEMENT:** Ce symbole indique que le défaut de prendre une action spécifiée pourrait causer des dommages physiques à l'utilisateur.



**ATTENTION:** Ce symbole indique que le défaut de prendre une action spécifiée peut entraîner des dommages à l'équipement.



**Info:** Ce symbole indique une information qui met l'accent ou des suppléments importants du texte principal.

### Consignes de sécurité

- Tous les travaux électriques doivent être effectués en conformité avec les codes locaux et nationaux électriques.
- Ce produit est conçu pour l'installation / du compartiment intérieur. Il ne doit pas être exposé à la pluie, la neige, l'humidité ou des liquides de tout type.
- Utiliser des outils isolés pour réduire le risque de choc électrique ou courts-circuits accidentels.
- Il n'y a pas de réparation par l'utilisateur contenues dans ce produit.
- Cet appareil est fourni avec une protection intégrale contre les surcharges.
- Puissance en direct peuvent être présents à plus d'un point depuis un onduleur utilisé à la fois DC (piles, PV, etc.,) et AC (utilitaire ou générateur) d'alimentation. Pour réduire le risque de choc électrique, assurez-vous que tout le câblage DC et AC est débranchée avant l'installation ou la maintenance sur le variateur. Mise hors tension de l'onduleur ne réduira pas ce risque, l'onduleur doit être totalement déconnectée de toutes les sources.
- Utiliser des méthodes de câblage classe 1 pour les connexions de câblage sur le terrain aux bornes d'un circuit de Classe 2.
- Côté ou étiquetés équipement doit être installé et utilisé conformément aux instructions figurant dans la liste ou l'étiquetage.
- Toujours vérifier le câblage avant de commencer l'onduleur.
- Utilisez des fils de cuivre seulement avec une cote de température minimale de 90° C.
- AC câblage ne doit pas être inférieure à 10 AWG (5,3 mm<sup>2</sup>) de cuivre de calibre.
- Les câbles de batterie ne doit pas être inférieur à # 4/0 AWG pour 12 et 24 volts systèmes et # 2/0 AWG pour calibre 48-volts systèmes. Frisées et scellé cosses en cuivre anneau des bornes avec un trou de 5/16 doit être utilisé pour se connecter à des bornes de courant continu sur l'onduleur.
- Couple toutes les connexions de câblage ca et les connexions de câbles à courant continu à des valeurs de couple nécessaires.
- La protection contre les surintensités des câbles de batterie doivent être fournis dans le cadre de l'installation du système.

- Le conducteur de courant alternatif de sortie neutre et les conducteurs à courant continu négatives ne sont pas connectés (servitude) au châssis inverseur. La fois l'entrée et des conducteurs de sortie sont isolés de l'enceinte et l'autre. La terre du système, si nécessaire, est de la responsabilité de l'installateur du système et doit se conformer à des codes locaux et nationaux et les normes électriques. Reportez-vous aux Section 2.10 "Au sol de système interactif" pour plus d'informations.

### Sûreté de batterie

- Utilisez les outils isolés et faites attention très en travaillant autour des batteries, ils peuvent produire les courants extrêmement élevés si au sujet dont court-circuité (par exemple, laissant tomber un outil en métal à travers la borne de batterie), pourrait causer un fi ou une explosion.
- Lisez et suivez les mesures de sécurité du fabricant de batterie avant d'installer l'inverseur et les batteries. Vérifiez toujours la polarité et la tension appropriées avant de relier les batteries à l'inverseur. Une fois que les batteries sont reliées à l'inverseur, assurez que l'entretien et les conditions de remplissage (c.-à-tension de charge et taux de charge) fournis par le fabricant de batterie sont suivis pour prolonger la vie des batteries et pour empêcher des dommages aux batteries tout en chargeant.
- Portez la protection d'oeil telle que des verres de sûreté, et l'évitez de toucher vos yeux et visage en travaillant avec des batteries pour garder n'importe quels fluide/corrosion sur la batterie des yeux et de la peau contactants. Ayez l'abondance de l'eau doux et du savon tout près et lavez complètement au cas où l'acide de batterie entrerait en contact avec la peau, l'habillement, ou les yeux. En cas de l'exposition aux yeux, à l'ood de fi ils pendant au moins 15 minutes avec l'attention médicale immédiate d'eau courante et de recherche. Le bicarbonate de soude neutralise l'électrolyte de batterie d'acide de plomb et le vinaigre électrolyte neutralise batterie renversée de NiCad et de NiFe ; selon votre type de batterie, gardez un approvisionnement en main près des batteries.
- Enlevez tous les bijoux tels que les anneaux, montres, bracelets, etc., en installant ou en exécutant l'entretien sur les batteries et l'inverseur. Une batterie peut produire un court-circuit courant assez haut aux bijoux en métal de soudage, causant les brûlures graves.
- Ne travaillez seul jamais. Toujours ayez quelqu'un dans la marge de votre voix ou clôturez assez pour venir à votre aide en travaillant autour des batteries.
- Employez les techniques de levage appropriées en travaillant avec des batteries.
- N'utilisez jamais les vieilles ou non essayées batteries. Examinez l'étiquette de chaque batterie pour assurer l'âge, type, et le code de date pour assurer toutes les batteries sont identique.
- Les batteries sont sensibles aux changements de la température. Installez toujours les batteries dans un environnement stable.
- Les batteries peuvent produire les gaz explosifs, ainsi installez les batteries dans un secteur well-ventilated. Pour des installations de compartiment ou de clôture, exhalez toujours les batteries du point le plus élevé à l'extérieur. Concevez la clôture de batterie pour empêcher l'accumulation et la concentration du gaz d'hydrogène dans des « poches » au dessus du compartiment.
- Fournissez au moins un pouce d'espace aérien entre les batteries pour fournir le refroidissement optimum.
- Ne fumez jamais ou permettez une étincelle près des batteries.
- Our empêcher une étincelle à la batterie et réduire la possibilité de l'explosion, reliez toujours les câbles au rst de fi de batteries.
- Reliez alors les câbles à l'inverseur. Ne chargez jamais une batterie congelée.

# Table of Contents

<b>1.0</b>	<b>Introduction</b>	<b>1</b>
1.1	MMP Series Overview	2
1.2	MMP External Components	3
1.3	MMP Internal Components	4
<b>2.0</b>	<b>Installation</b>	<b>8</b>
2.1	Preparation	8
2.1.1	Unpacking and Inspection	8
2.1.2	Required Materials and Tools	8
2.2	Location	10
2.3	Conduit Knockouts	10
2.4	Mounting	12
2.5	Wiring the MMP Enclosure – General Requirements	14
2.5.1	Disconnect Switch and Overcurrent Protection	14
2.5.2	General Wiring Requirements	14
2.5.3	Wire Routing	15
2.6	Torque Requirements	15
2.7	Electrical System Wiring Diagrams	15
2.8	DC Wiring	18
2.8.1	DC Wiring Guidelines	18
2.8.2	DC Wiring Connection Points	19
2.8.3	Inverter DC Overcurrent Protection and DC Disconnect	21
2.8.4	Inverter and Battery Bank Wire Sizing	21
2.8.5	DC Hardware Connections	22
2.8.6	Wiring the Battery Bank	23
2.8.7	Wiring the MMP Enclosure to the Battery Bank/Inverter	23
2.9	AC Wiring	24
2.9.1	AC Wiring Guidelines	24
2.9.2	AC Connections	24
2.9.3	AC Wire Size and Overcurrent Protection	27
2.9.4	AC Conductor Wiring	27
2.9.5	AC Wiring Configurations	28
2.10	MMP/Inverter System Grounding	33
2.10.1	Sizing the Grounding Electrode Conductors	34
2.10.2	Equipment Grounding Conductor	36
2.10.3	System Bonding Jumper	36
2.11	Removing the AC Neutral to Ground Connection	37
2.12	Removing the DC Negative to Ground Busbar	37
2.13	Wiring Accessories	38
2.14	Installation Checklist	40
2.15	Functional Test	42
<b>3.0</b>	<b>Operation</b>	<b>44</b>
3.1	Inverter DC Disconnect Breaker	45
3.2	AC Input Breaker	45
3.3	Inverter AC Output Breaker	45
3.4	Inverter AC Bypass Switch Breaker	45



## Table of Contents (Cont.)

<b>Appendix A – Optional Equipment and Accessories .....</b>	<b>48</b>
A1 Installing the Charge Controller Bracket.....	48
A2 Installing a Remote Control.....	50
A3 Installing a Battery Monitor.....	51
A4 Knockout Plate .....	52
A5 Inverter Hood Info .....	53
A6 Installing Optional DC Breakers .....	54
A7 Installing Lightning Arrestors.....	56
A8 MMP Back Panel Information .....	58
<b>Appendix B – Using the MMP in a Mobile Application.....</b>	<b>59</b>
<b>Appendix C – Warranty and Service.....</b>	<b>60</b>
C1 Limited Warranty .....	60
C2 How to Receive Repair Service.....	60

## List of Tables

Table 2-1, Torque Values for Busbars.....	15
Table 2-2, Torque Values for the DC Shunt and DC Disconnect Breaker .....	15
Table 2-3, Torque Values for the AC Terminal Blocks .....	15
Table 2-4, Recommended DC Wire to MMP Enclosure.....	21
Table 2-5, AC Input/Output Wiring Configurations .....	28
Table 2-6, AC Grounding Electrode Conductor Sizing .....	34
Table 2-7, Equipment Grounding Conductor Sizing .....	36
Table A-1, Mounting Holes Used for Charge Controllers .....	48



# List of Figures

Figure 1-1, MMP's Outside Components .....	3
Figure 1-2, MMPxxx-30D Internal Components .....	6
Figure 1-3, MMPxxx-30D AC Breakers .....	6
Figure 1-4, MMPxxx-60S Internal Components .....	7
Figure 1-5, MMPxxx-60S AC Breakers.....	7
Figure 2-1, MMP Series Simplified Installation Diagram .....	9
Figure 2-2, MMP Series Dimensions and Knockout Location/Sizes.....	11
Figure 2-3, Removing Knockouts .....	12
Figure 2-4, Keyhole Locations for Mounting .....	13
Figure 2-5, MMPxxx-30D System Wiring Diagram.....	16
Figure 2-6, MMPxxx-60S System Wiring Diagram.....	17
Figure 2-7, DC Wiring Connection Points.....	19
Figure 2-8, DC Wiring with Magnum Inverter.....	20
Figure 2-9, DC Connections – with Magnum Inverter Installed .....	22
Figure 2-10, AC Wiring Connections (MMPxxx-30D Models) .....	25
Figure 2-11, AC Wiring Connections (MMPxxx-60S Models) .....	26
Figure 2-12, AC Wiring for Single In – Single Out (30 A) Configurations .....	29
Figure 2-13, AC Wiring for Single In – Single Out (60 A) Configurations .....	30
Figure 2-14, AC Wiring for Dual In – Single Out Configurations .....	31
Figure 2-15, AC Wiring for Dual In – Dual Out Configurations .....	32
Figure 2-16, Grounding System for Inverter with MMP Enclosure.....	33
Figure 2-17, Single Connection to DC Ground Rod (Method 1) .....	34
Figure 2-18, Multiple Connections to DC Ground Rod (Method 2).....	35
Figure 2-19, Multiple Connections to DC Ground Rod (Method 3).....	35
Figure 2-20, Removing the AC Neutral to Ground Connection .....	37
Figure 2-21, Removing the DC Negative to Ground Busbar.....	37
Figure 2-22, REMOTE Communication Cable (300V) .....	38
Figure 2-23, NETWORK Communication Cable (300V).....	38
Figure 2-24, Extension Cable (300V) .....	38
Figure 2-25, Accessory Wiring using 300 Volt Communications Cables .....	39
Figure 2-26, AC Voltage Checks.....	43
Figure 3-1, MMP Functional Diagram .....	44
Figure 3-2, MMPxxx-30D Bypass Switch Operation .....	46
Figure 3-3, MMPxxx-60S Bypass Switch Operation .....	47
Figure A1-1, Charge Controller Bracket – Physical Dimensions .....	48
Figure A1-2, Holes Used to Mount Bracket on MMP Enclosure.....	49
Figure A2-1, Installing a Remote Control on the MMP Enclosure .....	50
Figure A3-1, Mounting the Sense Module .....	51
Figure A3-2, Wiring the Sense Module and DC Shunt.....	51
Figure A4-1, Attaching Knockout Plate.....	52
Figure A4-2, Knockout Plate Dimensions and Knockouts.....	52
Figure A5-1, Inverter Hood Dimensions .....	53
Figure A6-1, Installing DIN Rail-Mounted DC Breakers .....	54
Figure A6-2, Installing Back Panel Mounted DC Breakers.....	55
Figure A6-3, Wiring DC Breakers .....	55
Figure A7-1, Installing Lightning Arrestor on MMP Enclosure.....	56
Figure A7-2, Wiring Lightning Arrestor to MMP Enclosure .....	57
Figure A8-1, MMP Back Panel (BP-MMP) Information .....	58

## 1.0 Introduction

Congratulations on your purchase of the Mini Magnum Panel (MMP) enclosure, part of a new line of panel systems from Magnum Energy. Installing an inverter system is now as simple as mounting the MMP enclosure, installing the inverter, connecting the battery bank, and if needed, bringing in AC power from a generator or the utility. The inverter's required AC and DC disconnects and wire connection points are all together, and integrated in one self-contained enclosure.

This unit has been specifically designed to combine all of the major components required for a renewable energy system into a single, easy to install pre-wired enclosure. This includes: inverter/battery disconnect, AC overcurrent protection, grounding connections, and a full system inverter bypass switch as a convenient way to isolate the inverter for battery maintenance.

Designed for single inverter applications, this enclosure features convenient front panel operation and the optional front panel remote allows easy Magnum inverter set up, monitoring, and operation. In addition to saving time and money with a simple and easy inverter installation, this enclosure ensures safety and reliability by providing a UL and CSA certified, code compliant system.

### What makes the MMP enclosure stand out from the competition?

- It is engineered to combine the ease and cost savings of a pre-wired, factory-integrated system with the flexibility of a single person, field installed power system.
- The self-contained enclosure system is convenient and space-saving, reducing installation time and cost compared to a conventional approach using multiple interconnected components.
- Multiple models are available to meet the flexibility and power demands of your application.
- Specifically designed to fit Magnum inverters, but easily adaptable to connect other inverter systems in 12, 24, or 48 VDC standardized configurations.
- Includes a built-in AC bypass switch with full system current capability, and a DC disconnect breaker for safe and easy servicing of the inverter and/or battery bank.
- Additional space to install up to eight ½" (12.7mm) wide DIN rail-mounted breakers or four 1" (25.4mm) wide back-mounted breakers for use as DC load breakers; or, space to install PV disconnects or PV-Ground Fault Protection (PV-GFP).
- A full system capacity DC shunt (500 amps) installed to allow easy connection to a state-of-charge battery monitor.
- AC/DC wiring connections and circuit breaker operations are easily accessible from the front.

### Regulatory Compliance

The MMP has been designated as Interconnection System Equipment (ISE) and has been evaluated by Intertek Testing Services (also known as ETL). ETL is a Nationally Recognized Testing Laboratory (NRTL) and has listed the MMP enclosure to the following product safety standards and ratings:

#### Standards

- UL1741 Standard for Safety of Inverters, Converters, Controllers and Interconnection System Equipment for Use with Distributed Energy Resources (Edition 2)
- CSA C22.2 No. 107.1, General Use Power Supplies – R2006 (Edition 3)

#### Ratings

- Maximum battery input: 160VDC
- Maximum PV input voltage (DC): 300VDC
- Maximum DC input short circuit current (DC): 10,000 AIC
- Operating voltage range (AC): 120-240VAC nominal
- Normal operation range: 5000 VA @25°C (MMP)



**Info:** NRTL's are qualified organizations that meet Occupational Safety and Health Administration (OSHA) regulations to perform independent safety testing and product certification.

## Introduction

### 1.1 MMP Series Overview

The MMP enclosure is available in four basic configurations. This section lists the four models and the enclosure's main components and features.

#### Individual Models:

- **MMP175-30D** (Mini Magnum Panel, 175 ADC breaker, dual 30 AAC bypass/input breakers)
- **MMP175-60S** (Mini Magnum Panel, 175 ADC breaker, single 60 AAC bypass/input breakers)
- **MMP250-30D** (Mini Magnum Panel, 250 ADC breaker, dual 30 AAC bypass/input breakers)
- **MMP250-60S** (Mini Magnum Panel, 250 ADC breaker, single 60 AAC bypass/input breakers)

#### Standard Features:

- Enclosure is steel construction with durable white powder coat finish
- Battery/inverter DC disconnect breaker (175 or 250 amps)
- Inverter AC input overcurrent protection breakers
- Pre-wired AC bypass switch for inverter isolation/battery maintenance
- Front mount AC and DC breakers for quick and easy operation
- AC and DC ground screw type compression terminals (no lugs required)
- 500A/50mV DC shunt installed for easy connection to battery status monitor
- Easy field wiring with front-mounted AC and DC input/output terminals
- Enclosure and components are UL/CSA certified and designated for indoor use
- Configurations available for both single 120 VAC and 120/240 VAC systems
- DC negative and ground busbars (negative can be isolated if PV-GFP device installed)
- Battery positive busbar for DC loads and PV arrays included
- Provides mounting for DIN rail or back-mounted DC load/disconnect breakers
- Integrates directly with Magnum MS, MS-PAE, and RD Series inverters
- Knockouts for inverter and battery cables, PV in/out, DC breakers
- Stud terminal available for large DC wire if used as system ground
- Data cables with 300-volt rated insulation to allow 240 VAC inverter installations
- Inverter hood to allow a Magnum inverter to be mounted vertically

#### Physical Features:

- MMP dimensions (H x W x D): 18" x 13" x 6.75" (45.7cm x 33cm x 17.1cm)
- MMP weight: 22.5 lbs. (10.2 kg)
- Shipping dimensions (H x W x D): 22" x 15" x 12.5" (56.9cm x 38.1cm x 31.8cm)
- Shipping weight: 31.5 lbs. (14.3 kg)

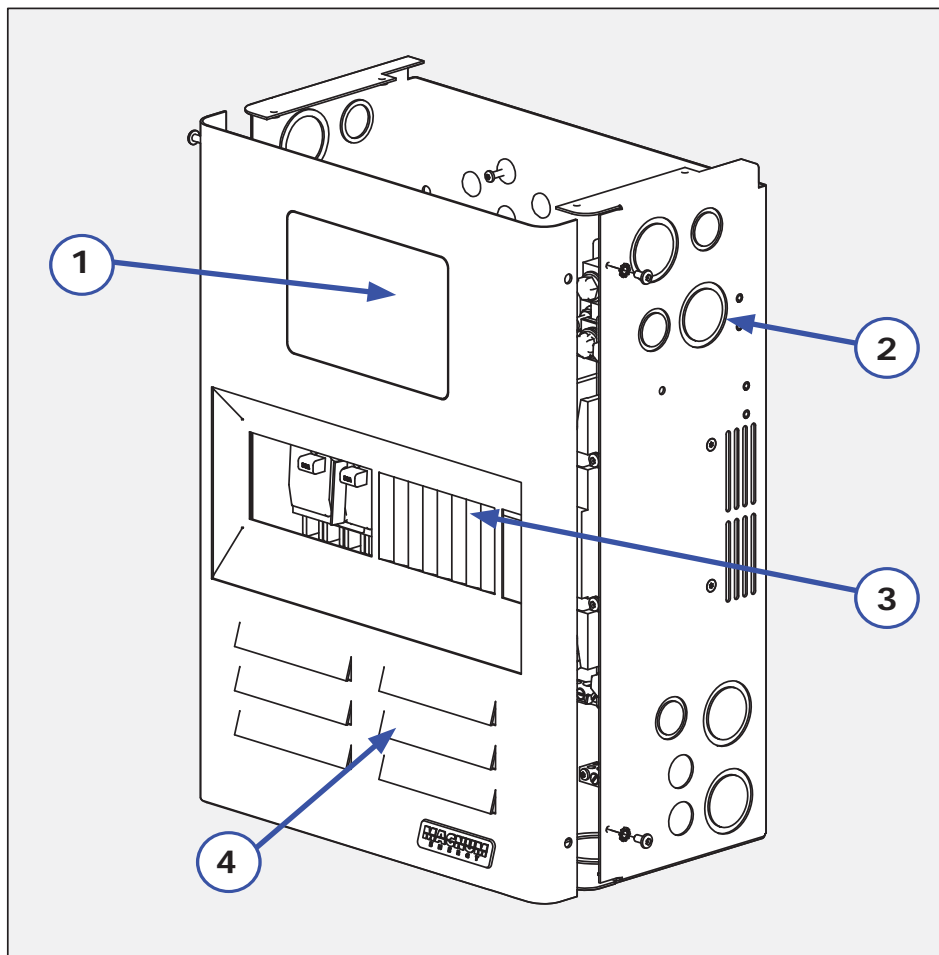
#### Optional Accessories/Components:

- **ME-RC** – Basic Remote Control with LCD display; allows inverter (or connected accessory) to be configured and monitored, and maintains the critical settings in non-volatile memory.
- **ME-ARC** – Advanced Remote Control with LCD display; has all the features of the ME-RC remote, but also configures the advanced features of the inverter (or any connected accessory).
- **ME-BMK-NS** – Battery Monitor; determines battery State of Charge (DC shunt not included).
- **ME-AGS-N** – Automatic Generator Start Controller (Network version); automatically starts/stops generators.
- **BP-MMP** – Metal Backplate; for mounting the Magnum inverter and MMP enclosure, and is UPS shippable. See Figure A8-1 in Appendix A for more specific information.
- **DC Breakers** – Space for up to four E-Frame/back-mounted (1" width) or eight Q-Frame/DIN rail-mounted (1/2" width) DC breakers.
- **MMP-KP** – A top cover plate with knockouts to allow other (non-Magnum) inverter installations. See Figure A4-1 in Appendix A for more specific information.

## 1.2 MMP External Components

As shown in Figure 1-1, the main components found on the outside of the MMP enclosure are:

- 1 **Remote Blank Plate** – This plate is removed when an optional ME-RC or ME-ARC remote control is installed.
- 2 **Conduit Knockouts** – Knockouts to allow metal and PVC conduits. For dimensions and sizes see Figure 2-2.
- 3 **Knockout Panels** – Eight 1/2" rectangular knockout panels provided to install additional DC circuit breakers.
- 4 **Front Cover** – The front cover is removed to allow access to the internal components. Four #10 x 3/8", T25 Torx drive screws are used to hold the front cover to the enclosure.



*Figure 1-1, MMP's Outside Components*

## Introduction

### 1.3 MMP Internal Components

The following components are found inside the MMP enclosure (refer to Figures 1-2 thru 1-5):

- 1 **DC Negative to Ground Connection** – A busbar connects the DC negative to the system ground. This busbar can be removed if the primary DC negative-to-ground connection is made elsewhere in the system (see Section 2.12).
- 2 **Mounting Dimples (x4)** – These dimples allow the optional ME-BMK-NS (Battery Monitor Kit without DC shunt) to be installed. For more information on mounting the battery monitor see Section A3 in Appendix A.
- 3 **Mounting Keyholes (x4)** – Four keyholes for mounting the enclosure. See Figure 2-4 for size information on these keyholes.
- 4 **Inverter AC Wiring Terminal** – Terminal for connecting the inverter’s AC input and output wires.
- 5 **AC Breakers** – This AC breaker assembly is pre-wired at the factory and consists of the inverter bypass switch, and the inverter input and output disconnect. These breakers provide overcurrent protection and a way to disconnect the AC wiring inside the MMP enclosure. These breakers can also provide overcurrent protection to the AC input source and output load circuits if the minimum recommended AC wiring sizes are used.
- 6 **External AC Wiring Terminal** – Terminal for connecting the external AC source (utility/generator) and the electrical panel that will be powered by the inverter.
- 7 **AC Neutral to Ground Connection** – A wire (green) connects the AC neutral to the system ground. This green wire can be removed from the ground busbar if the primary AC neutral-to-ground connection is made elsewhere in the system (see Section 2.11).
- 8 **Ground Busbar** – This busbar is connected to the MMP enclosure chassis and is used to tie AC and DC equipment grounds to a common point. This busbar has dual hole sizes—three #14 to #1/0 AWG and six #14 to #6 AWG—with screw type compression terminals (no ring lugs required).
- 9 **Inverter’s DC Negative Connection Busbar** – Inverter’s DC negative terminal connects to the top of this busbar.
- 10 **Inverter’s DC Positive Connection Busbar** – Inverter’s DC positive terminal connects to the top of this busbar.
- 11 **DC Shunt** – A 500-amp/50 mV shunt installed in the DC negative side that is used to measure the amperage flowing between the battery and the inverter (and any DC loads connected). This shunt is pre-installed so that a battery monitor may be easily connected to display the current flow. See Section A3 in Appendix A for information on installing and wiring the ME-BMK-NS battery monitor inside the MMP enclosure.
- 12 **Battery Negative Connection** – The bottom of the DC shunt is the connection point to the negative terminal of the battery bank.

- 13 DC Ground Stud** – This 5/16" stud is connected to the MMP enclosure chassis and is provided as a connection point to the DC grounding electrode when the conductor is larger than #1/0 AWG.
- This 5/16" stud also connects to the DC shunt through a busbar and serves as the DC negative-to-ground connection point. If installing a PV-GFP device, this busbar must be removed (see Section 2.12).
- Note: For ground wires #1/0 AWG or smaller, use the DC negative busbar (Item 20).*
- 14 DIN Rail Track** – For installing up to eight 1/2" (12.7mm) wide, DIN rail-mounted, Q-Frame type breakers. These breakers can be used for connecting DC loads or installing a PV-GFP device.
- 15 Mounting Holes (x8)** – For installing up to four 1" (25.4mm) wide, back-mounted, E-Frame type breakers. These breakers can be used for connecting DC loads or installing a PV-GFP device.
- 16 Inverter DC Disconnect Breaker** – This disconnect is a heavy-duty high amperage circuit breaker specifically designed for the MMP enclosures. It provides an easy and convenient way to isolate the inverter from the battery, and meets the NEC/CEC requirements for DC overcurrent protection when used in accordance with the installation instructions in this manual. The amperage rating depends on the MMP model (175 or 250 amps).
- 17 Battery Positive Connection** – The bottom of the inverter's DC disconnect is the connection point to the positive terminal of the battery bank. The DC disconnect has a front connected terminal with 3/8-16 captive nuts.
- 18 Battery Positive Busbar** – This busbar is connected to the battery bank positive through the bottom of the inverter DC disconnect. This busbar is the battery positive common point for connecting additional DC circuits, such as from the output of a charge controller or connecting to DC load breakers.
- This busbar is rated to handle 120 amps, and has dual hole sizes—two # 14 to #1/0 AWG and five #14 to #6 AWG—with screw type compression terminals (no ring lugs required).
- 19 PV Positive Busbar** – This busbar provides a convenient connection point inside the MMP for the positive output from a PV array and the positive input to the PV charge controller.
- This busbar is rated to handle 120 amps, and has dual hole sizes—two # 14 to #1/0 AWG and five #14 to #6 AWG—with screw type compression terminals (no ring lugs required).
- 20 DC Negative Busbar** – This busbar is connected to the battery bank negative through the load side of the DC shunt. This busbar is the battery negative common point for connecting additional DC circuits, such as from the DC negative output of a charge controller or combining the negatives of DC load circuit breakers.
- This busbar is rated to handle 120 amps, and has dual hole sizes—two # 14 to #1/0 AWG and five #14 to #6 AWG—with screw type compression terminals (no ring lugs required).



# Introduction

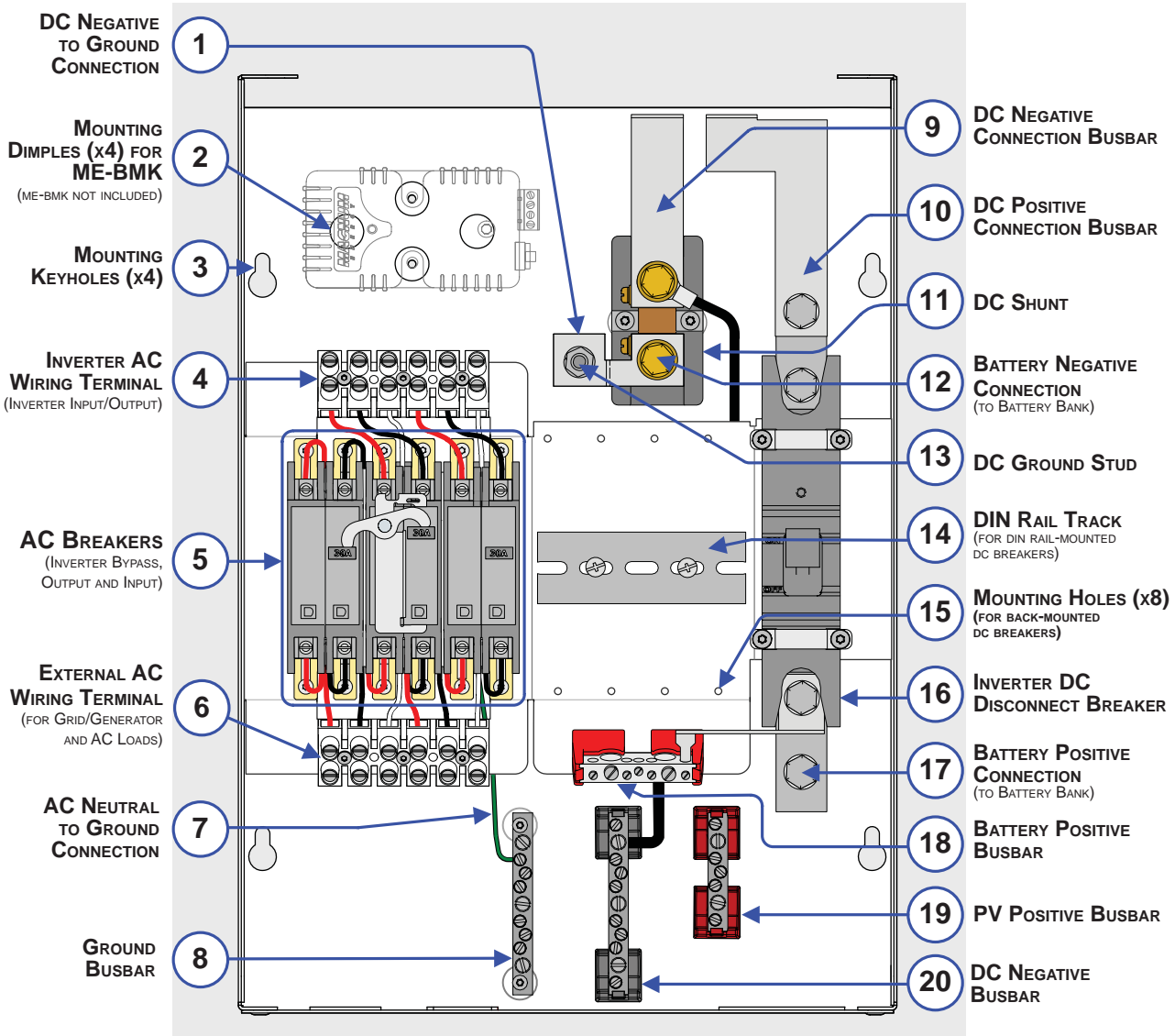


Figure 1-2, MMPxxx-30D Internal Components

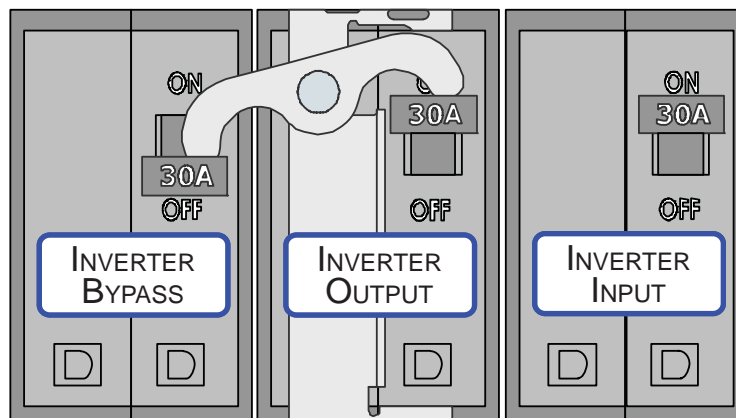


Figure 1-3, MMPxxx-30D AC Breakers



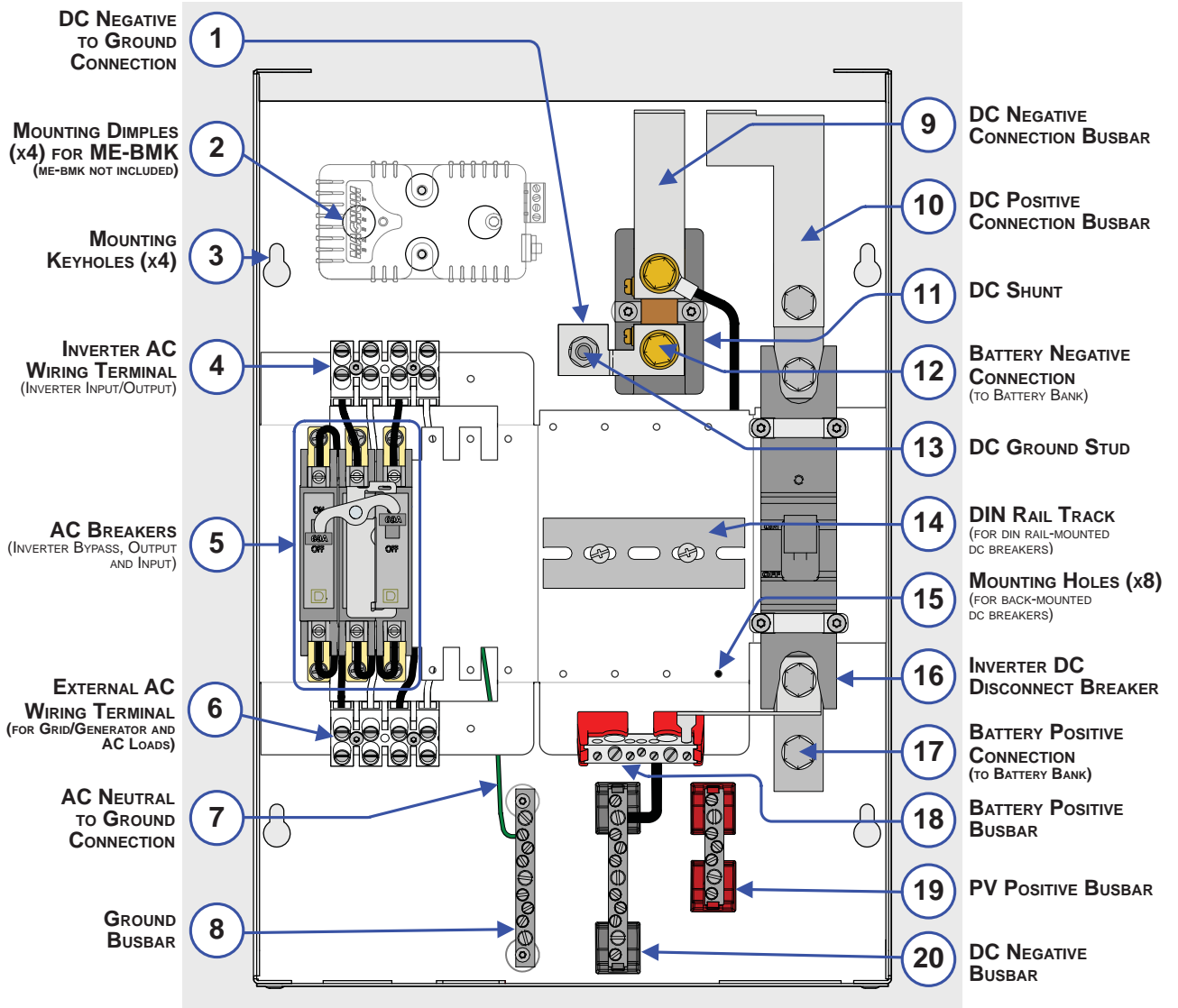


Figure 1-4, MMPxxx-60S Internal Components

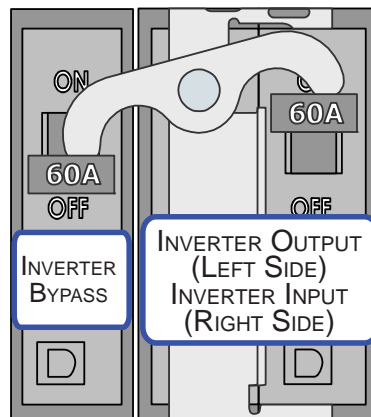


Figure 1-5, MMPxxx-60S AC Breakers

### 2.0 Installation



**WARNING:** Installations should be performed by qualified personnel, such as a licensed or certified electrician. It is the installer's responsibility to determine which safety codes apply and to ensure that all applicable installation requirements are followed. Applicable installation codes vary depending on the specific location and application of the installation.



**CAUTION:** Review the "Important Safety Instructions" on pages ii-v before any installation.



**CAUTION:** The MMP enclosure is heavy. Use proper lifting techniques during installation to prevent personal injury.

The simplified system diagram shown in Figure 2-1 should be reviewed to assist you in planning and designing your installation. This drawing is not intended to override or restrict any national or local electrical codes, nor should it be the determining factor as to whether the installation is compliant – that is the responsibility of the electrician and the onsite inspector.

### 2.1 Preparation

Before proceeding, read the entire Installation section to determine how you are going to install your MMP enclosure. Save time and avoid common, costly mistakes by thoroughly planning before you start.

#### 2.1.1 Unpacking and Inspection

Carefully remove the MMP enclosure from its shipping container and inspect all contents. Verify that the following items are included:

- MMP enclosure
- Inverter hood
- Owner's manual
- RJ14 extension cable
- 6' Network cable
- 6' Remote cable
- 3/8-16 x 1" bolt
- 3/8" split lock washer
- Four 8-32 x 1/2 Phillips drive, black colored screws (used to mount an optional remote control)

If items appear to be missing or damaged, contact your authorized Magnum Energy dealer or Magnum Energy.

Save your proof-of-purchase as a record of your ownership; it will also be needed if the unit should require in-warranty service.

#### 2.1.2 Required Materials and Tools

The following material and tools may be required for installing this equipment:

##### Materials

- Conduit, strain-reliefs, and appropriate fittings
- Electrical tape
- Conductors/cables for wiring
- 1/4" mounting bolts and lock washers
- Wire ties

##### Tools

- Miscellaneous screwdrivers
- Drill and drill bits
- Level
- Torque wrenches
- Insulated pliers
- Pencil or marker
- 1/2" wrench
- Ratchet drives
- Wire cutters/strippers
- Multimeter

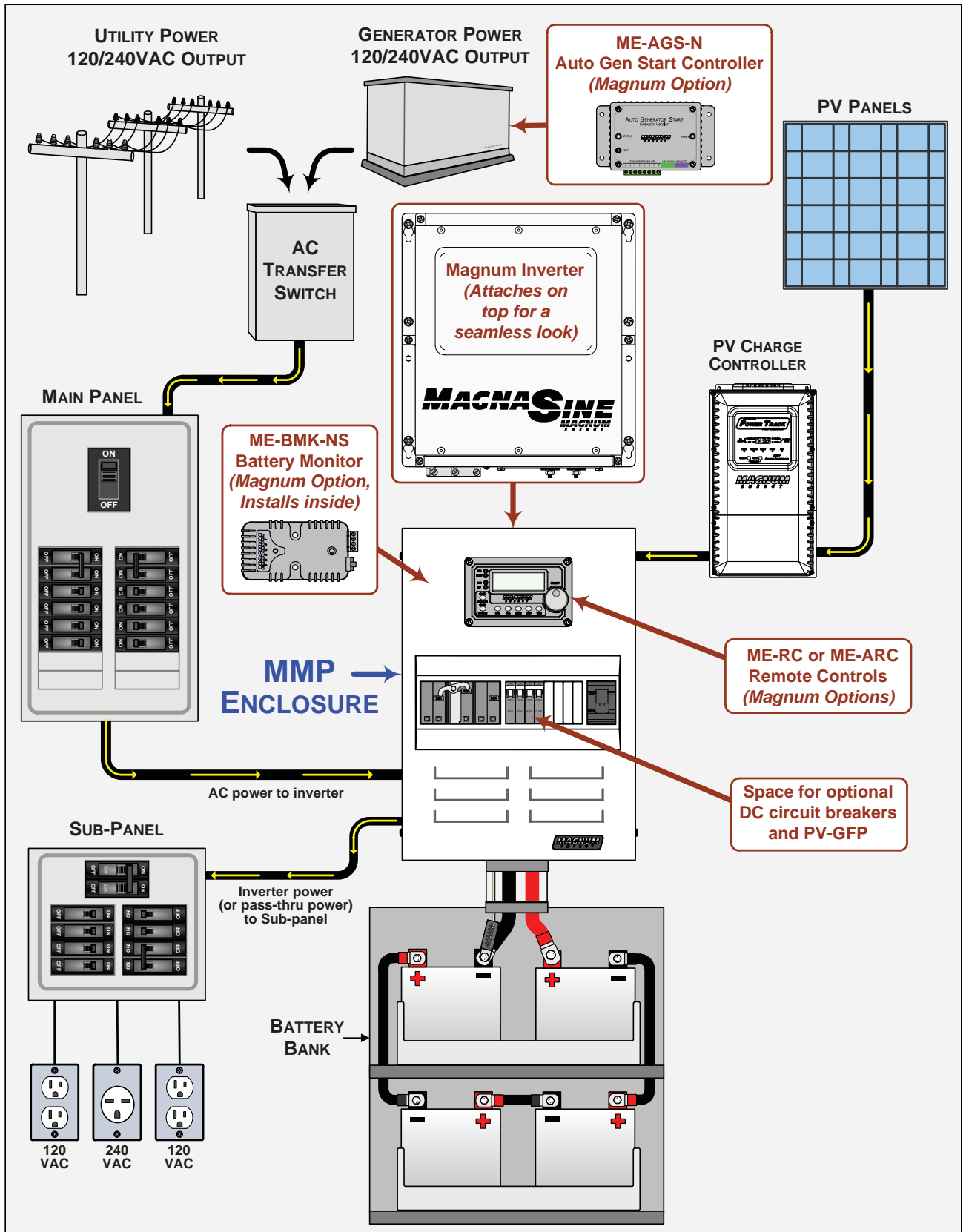


Figure 2-1, MMP Series Simplified Installation Diagram

## Installation

### 2.2 Location

Refer to the dimensional drawing in Figure 2-2 to determine an appropriate area to install the MMP enclosure/inverter system. Install it only in a location that meets the following requirements:

**Clean and Dry** – The MMP/inverter system must be mounted indoors in a relatively cool, clean, and dry environment.

**Ventilation** – If a Magnum inverter is installed on the MMP enclosure, the inverter will pull in air through the intake vents. In order for the inverter to provide full output power and avoid over-temperature fault conditions, do not cover or block the MMP enclosure ventilation openings or install it in an area with limited airflow. At the minimum, allow three inches of clearance to the left and right sides of the MMP enclosure to provide adequate ventilation.

**Close to the Battery Bank** – The MMP enclosure/inverter system should be located as close to the batteries as possible. This is to ensure the battery cable length is kept as short as possible. Long DC wires tend to lose efficiency and reduce the overall performance of an inverter. However, the MMP enclosure, the inverter, and any other equipment that can spark (or that corrosion could damage) should not be installed in the same compartment/room as the batteries or mounted where it will be exposed to gases produced by the batteries. These gases are corrosive and will damage this equipment; also, if these gases are not ventilated and if allowed to collect, they could ignite and cause an explosion. Consult your battery supplier for proper installation requirements.



**Info:** Consult your inverter owner's manual to determine the proper sized inverter-to-battery cables for the distance that is used. However, this cable must not be sized any smaller than the minimum size requirement for the DC disconnect breaker in the MMP enclosure. The MMP175 models require a minimum 00 (2/0) AWG cable, and the MMP250 models require a minimum 0000 (4/0) AWG cable.

**Safe** – Keep any flammable/combustible material (e.g., paper, cloth, plastic, etc.,) that may be ignited by heat, sparks or flames at a minimum distance of twelve feet away from the MMP/inverter system. Do not install the MMP/inverter system in any area that contains extremely flammable liquids like gasoline or propane, or in locations that require ignition-protected devices. Sparks from relays, circuit breakers, etc., could ignite the fumes or spills.

**Accessible** – Do not block access to the front of the MMP enclosure. Maintain at least a 36" (91 cm) clear space in front to access the AC and DC wiring terminals and connections inside the MMP enclosure, as they will need to be checked and tightened periodically.

### 2.3 Conduit Knockouts

The MMP enclosure comes standard with knockouts for 1/2", 3/4", 1", 1¼", 1½", and 2" conduits. Figure 2-2 shows the location of these conduit knockouts. The 1/2", 3/4", and 1" knockouts are for the PV array, DC loads, and other smaller input cables. Select the appropriate knockout that is close to the terminal that the wire will connect to, or whichever one works for the way your field wiring comes in. The 1½" and 2" knockouts on the bottom of the MMP enclosure are used to connect to the battery bank.



**Info:** The knockouts can be easily removed by tapping the edge with a straight bladed screwdriver and a hammer, then twist out with pliers. Refer to Figure 2-3.

Before removing the appropriate knockouts and mounting the MMP enclosure, think about whether you are going to use cable clamps or conduit and all the different wiring required, such as:

- Wiring from the MMP enclosure to an AC sub-panel
- Wire runs from the utility and/or a generator to the MMP enclosure
- Battery cable wiring from the battery bank to the MMP enclosure
- Additional wiring from any external DC source (PV, wind, or hydro) to the MMP enclosure
- Small signal wiring (battery sensors, battery monitoring, auto gen starting)
- Attaching lightning arrestors
- PV charge controller wiring

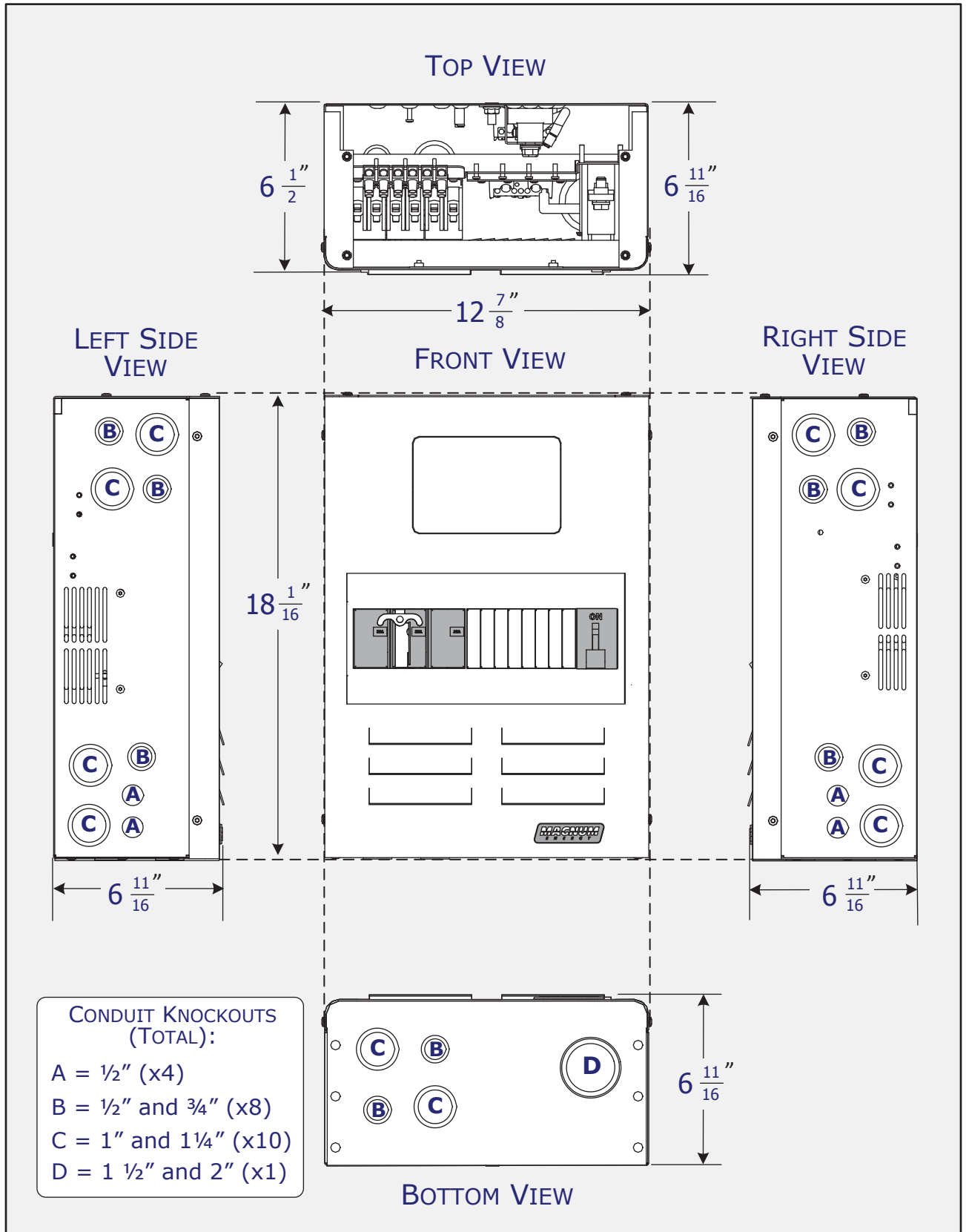
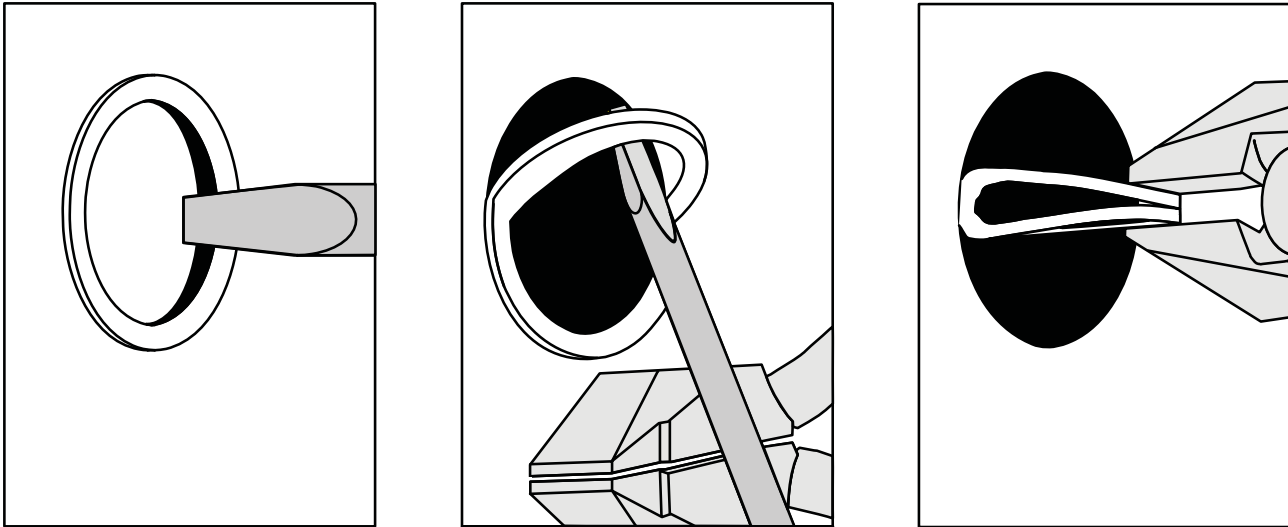


Figure 2-2, MMP Series Dimensions and Knockout Location/Sizes

## Installation



*Figure 2-3, Removing Knockouts*

### 2.4 Mounting

To meet regulatory requirements, the MMP enclosure must be mounted on a vertical surface (on a wall) in an upright position, as shown in Figure 2-4. The DC breaker will not operate properly unless in the vertical position.

Note the height you want to locate the MMP enclosure, and ensure you can access any controls and wiring terminals. Refer to the physical dimensions as shown in Figure 2-2, or use the base of the MMP as a template to mark your mounting screw locations. After marking the mounting screw locations, firmly secure the MMP/inverter to the solid vertical surface using appropriate mounting hardware.

This surface and the mounting hardware must also be capable of supporting at least three times the combined weight of all the components (i.e., MMP enclosure, inverter, and any other accessory mounted). When considering the strength of the support surface, remember the MMP enclosure weighs 22.5 lbs. (10.2 kg), and the Magnum inverter can weigh up to 60 lbs. (27.2 kg).

If installing a Magnum inverter on the MMP enclosure, the inverter base can reach a temperature up to 194°F (90°C); it is recommended that it should be mounted on a non-combustible surface\*.

To meet regulatory requirements with a Magnum inverter mounted vertically, the included inverter hood (PN: MP-HOOD) must be installed on the top to prevent the risk of fire from objects falling into the inverter. See Figure A5-1 in Appendix A for more information on the inverter hood.



**Info:** Magnum provides a steel backplate (PN: BP-MMP) that has a suitable surface and the required support for mounting the MMP enclosure and Magnum inverter together. For information and dimensions on this backplate, see Figure A8-1 in Appendix A.



**Info:** If mounting the MMP enclosure to wood (without a Magnum inverter), use at least a #10 gauge sheet metal or wood screw. For concrete or hollow walls use a minimum 1/4 inch bolt and anchor.

\* *Non-combustible surface – A surface made of material that will not ignite, burn, support combustion, or release flammable vapors when subjected to fire or heat as per the ASTM E136 standard. For the most part, these are materials that are largely comprised of inorganic materials such as stone, steel, iron, brick, tile concrete, slate, and glass. Common building materials such as gypsum board as well as any paint, wall coverings, and certainly wood will not pass.*

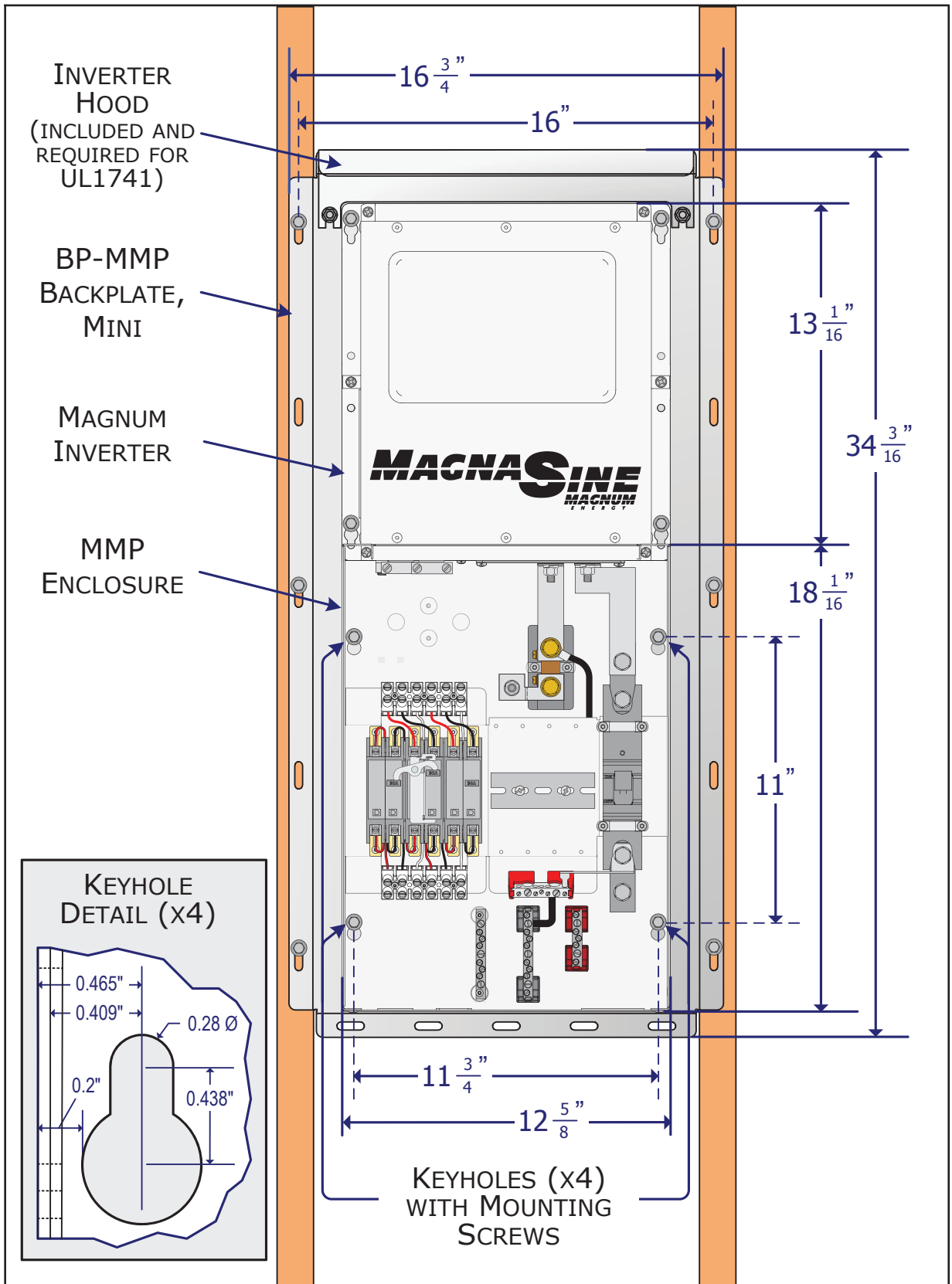


Figure 2-4, Keyhole Locations for Mounting



### 2.5 Wiring the MMP Enclosure – General Requirements

This section describes the requirements and recommendations for wiring to the MMP enclosure. Read all instructions before wiring the MMP enclosure. **All wiring should meet local codes and standards and be performed by qualified personnel such as a licensed electrician.**

Refer to the NEC (National Electric Code, ANSI/NFPA 70) for the United States and the CEC (Canadian Electrical Code) for Canada which provide the standards for safely wiring residential and commercial installations.



**WARNING:** The AC neutral and DC negative are bonded to ground in this enclosure. If the AC or DC circuits are already bonded to ground elsewhere in your system, you must remove the DC and/or AC bonding inside this enclosure. Refer to Section 2.11 and 2.12 to remove the AC and/or DC ground bond connection.



**WARNING:** The AC neutral must be connected to safety ground (often called a “bond”) in one, and only one, place at a time. More than one neutral to ground bond can cause “ground loop” currents, which can trip GFCIs, cause an electrical shock hazard, and may be the reason for other annoying side effects. In attempting to install the MMP in a mobile application (i.e., RV, truck, or boat), refer to Appendix B for more information.



**WARNING:** Ensure all sources of DC power (i.e., batteries, solar, wind, or hydro) and AC power (utility power or AC generator) are de-energized (i.e., breakers opened, fuses removed) before proceeding—to prevent accidental shock.

#### 2.5.1 Disconnect Switch and Overcurrent Protection

For residential and commercial electrical systems, the NEC/CEC requires a disconnect switch and overcurrent protection for all ungrounded conductors on the AC side as well as the DC side. The MMP enclosure provides both AC and DC circuit breakers that are used as the disconnect switch. These circuit breakers can also be used as the overcurrent protection device when the ampacity of the wire and its insulating material, voltage, and temperature rating are correctly sized to the DC circuit breakers in your MMP enclosure. Refer to the appropriate installation section (AC Wiring or DC Wiring) to determine the minimum recommended wire size required.

#### 2.5.2 General Wiring Requirements

- The AC and DC wires into and out of the MMP enclosure must be protected as required by code. This can be done by using jacketed wires or by feeding the wires through conduit.



**Info:** If the strain reliefs on the Magnum inverter are not required, they can be removed and replaced with 3/4” grommets.

- Use proper clamps or other approved methods for securing the cable/conduit to the enclosure.
- Do not mix AC and DC wiring in the same conduit. The MMP enclosure is specifically approved/ designed for both AC and DC wiring. However, where DC wiring must cross AC or vice-versa, try to make the wires at the crossing point 90° to one another.
- Use only copper wires with a minimum rating of 150V, 75°C if only 120 VAC power is being used; or, with a minimum rating of 300V, 75°C if 120/240 VAC power is being used.
- In a system where one conductor is grounded the wire colors on the DC side and AC side are the same. The insulation on all grounded conductors (DC negative/AC neutral) must be white, gray, or any color except green if marked with white at each termination (marking only allowed on 6 AWG or larger conductors). The equipment grounding conductors must be bare (no insulation), or have green or green with yellow-striped insulation or identification. The hot ungrounded conductor (DC positive/AC hot) is usually red or black.
- Terminals containing more than one conductor must be listed for multiple conductors.
- The connectors or terminals used on flexible, fine-stranded conductors must be specifically marked or labeled for use with fine-stranded conductors.
- The MMP enclosure includes wires (along with communication cables) with insulation rated for at least 300 volts, which allows 120/240 VAC inverters to be installed. If installing a 120/240 VAC inverter, the installer must also provide wires (both power and communication) with the insulation rated for at least 300 volts.

### 2.5.3 Wire Routing

Before connecting any wires, determine all wire routes to and from the MMP enclosure/inverter. Typical routing scenarios are:

- AC input wiring from the main AC panel or from a generator to the MMP enclosure
- AC input and output from the MMP enclosure to the inverter
- DC wiring from the batteries to the MMP enclosure
- DC wiring from the inverter to the MMP enclosure
- AC output wiring from the MMP enclosure to the AC sub-panel or to dedicated circuits
- Battery Temperature Sensor cable from the inverter to the batteries
- Remote control cable to the inverter through the MMP enclosure
- Ground wiring to and from the MMP enclosure

### 2.6 Torque Requirements

Follow the specific torque recommendations below to ensure your fasteners are tightened sufficiently. To ensure your connections are correct, you should use an accurate, quality torque wrench. It is highly recommended to go back over all fasteners and re-torque after five days and every six months thereafter.



**CAUTION:** AC and DC power/wire connections that are under-torqued could become loose and result in a fire hazard. On the other hand, over-tightening a bolt could cause the fastener to be snapped off.

**Table 2-1, Torque Values for Busbars**

Torque values for the ground busbar, DC negative busbar, and DC positive busbar (these busbars have different torque values for the small and large screws)

Wire Size	Busbar Screw Size Torque Values	
	10-32 (Small Screw)	5/16-24 (Large Screw)
#14 to #10 AWG	15 in. lbs. (1.7 N-m)	35 in. lbs. (4.0 N-m)
#8 AWG	20 in. lbs. (2.3 N-m)	40 in. lbs. (4.5 N-m)
#6 AWG	25 in. lbs. (2.8 N-m)	45 in. lbs. (5.1 N-m)
#4 AWG	NA	45 in. lbs. (5.1 N-m)
#3 to #1/0 AWG	NA	50 in. lbs. (5.6 N-m)

**Table 2-2, Torque Values for the DC Shunt and DC Disconnect Breaker**

<b>3/8-16 Bolt Torque Value</b>
10 to 12 ft. lbs. (13.6 to 16.3 N-m)

**Table 2-3, Torque Values for the AC Terminal Blocks**

Wire Size	Slotted M5 Screw Torque Values
#14 to #6 AWG	16.0 in. lbs. maximum (2.0 N-m maximum)

### 2.7 Electrical System Wiring Diagrams

Diagrams of the AC and DC wiring for the MMP Series enclosure are shown in Figures 2-5 and 2-6, and are provided to assist you or your system installer. Due to the variety of applications and differences in local and national electrical codes, these wiring diagrams should be used as general guidelines only. They are not intended to override or restrict any national or local electrical codes; and, the diagrams should not be the determining factor as to whether the installation is compliant, that is the responsibility of the electrician and the on-site inspector.

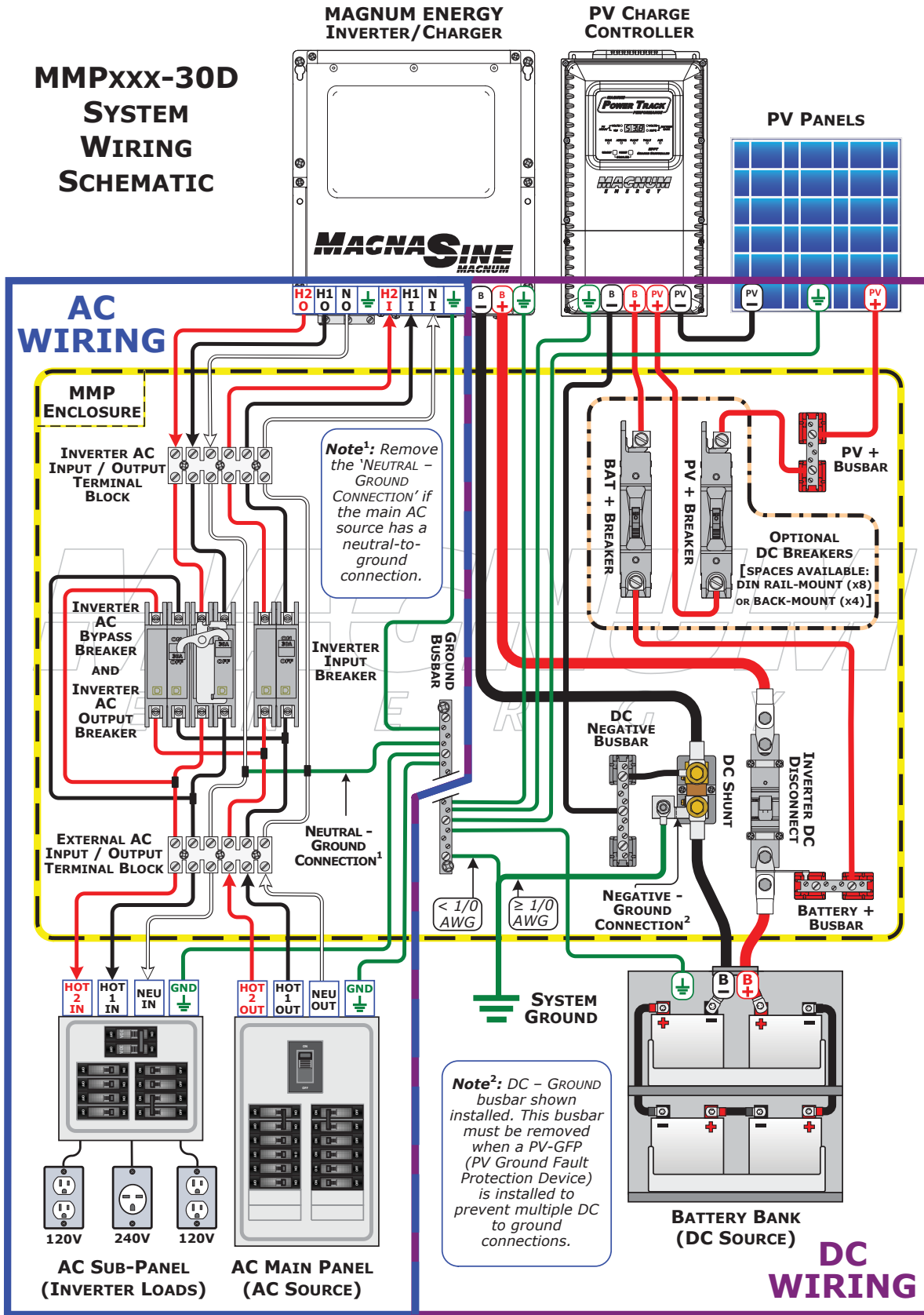


Figure 2-5, MMPxxx-30D System Wiring Diagram

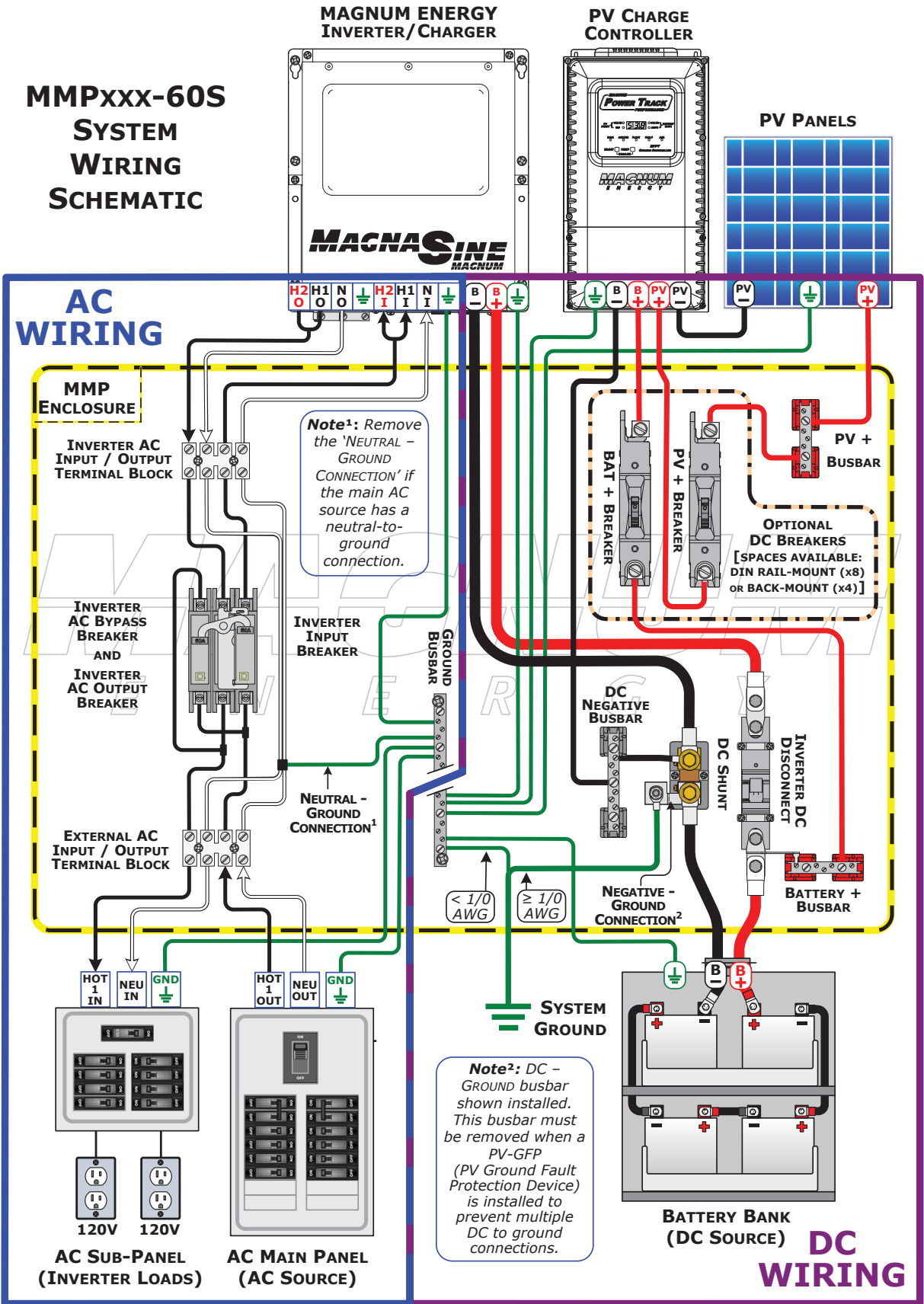


Figure 2-6, MMPxxx-60S System Wiring Diagram

## Installation

### 2.8 DC Wiring

This section describes the DC wiring from inside the MMP enclosure to the inverter and battery bank. Figure 2-7 shows the connection points for all battery bank and inverter (DC side) wiring inside the MMP enclosure. If installing optional DC breakers, see Section A7 in Appendix A.

The DC wiring for the MMP enclosure is further detailed in Figure 2-9. This diagram should be reviewed to assist in wiring the DC circuits, however, it is not intended to override or restrict any national or local electrical codes. This drawing should not be a determining factor as to whether the installation is compliant, that is the responsibility of the electrician and the onsite inspector.

#### 2.8.1 DC Wiring Guidelines



**WARNING:** During normal operation, the terminals, busbars, and electrical components inside the MMP enclosure may be energized – DO NOT TOUCH. Disconnect all power sources before removing the cover.



**WARNING:** Even though DC voltage is “low voltage”, significant hazards may be present, particularly from short circuits of the battery system.



**CAUTION:** Before wiring the DC cables, review the safety information at the beginning of this manual and the following information to ensure a safe and long-lived system.



**CAUTION:** If you are using fine-stranded DC cables, the crimp or compression lug used must be specifically marked or labeled for use with fine-stranded conductors. Failure to use the proper terminal may cause the connection to heat-up, and may eventually fail or become a fire hazard.



**CAUTION:** DO NOT connect the battery cables to the inverter until all wiring is complete and the correct DC voltage and polarity have been verified.

- When the inverter is installed in a Photovoltaic System, the NEC requires that the DC circuit conductors and overcurrent devices to the inverter be sized to carry not less than 125% of the inverter’s maximum current rating.
- The DC positive and negative cables from the battery bank should be tied together with wire ties or electrical tape approximately every six inches. This helps improve the surge capability and reduces the effects of inductance, which improves the inverter waveform and reduces the wear of the inverter’s filter capacitors.
- Crimped and sealed copper compression lugs with a 3/8” hole should be used to connect the battery cables to the DC disconnect breaker and the DC shunt inside the MMP enclosure.
- The battery bank voltage MUST match the DC voltage required by the inverter (i.e., 24-volt battery bank for a 24-volt inverter), or the inverter may be damaged.
- The DC cables must be of a type listed for use in conduit (RHW or THW).
- To ensure the maximum performance from the inverter, all connections from the battery bank to the inverter through the MMP enclosure should be minimized, the exception is the DC circuit breaker in the positive line and the DC shunt in the negative line. Any other additional connection will contribute to additional voltage drops and may loosen during use.
- All wiring to the inverter and battery terminals should be checked periodically (once a month) for proper tightness. Refer to the torque requirements in Tables 2-1 to 2-3.
- After making the battery connections and ensuring they are properly tightened, cover the outside of the connection with petroleum jelly or an antioxidant grease/spray. Do not put jelly/anti-corrosion grease between the terminal and the battery cable.
- Ensure the color code for the DC cables/wires are correct: RED for positive (+); WHITE for negative (-); and GREEN, GREEN/YELLOW, or bare for DC equipment grounds.

### 2.8.2 DC Wiring Connection Points

Figure 2-7 shows the connection points for the DC wiring inside the MMP enclosure.

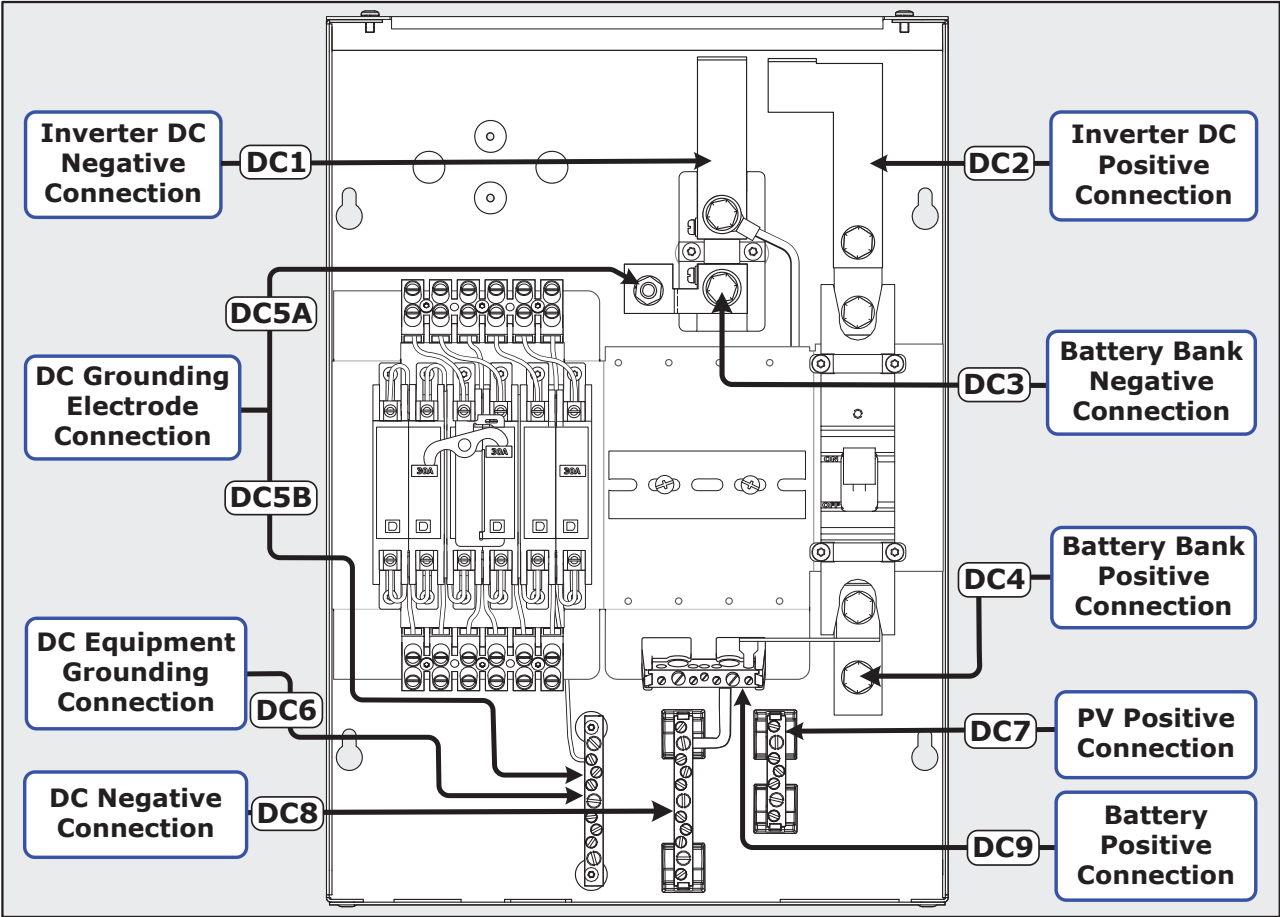


Figure 2-7, DC Wiring Connection Points

- DC1** **Inverter DC Negative Connection** – Top of DC negative busbar connects to Magnum inverter’s DC negative terminal.
- DC2** **Inverter DC Positive Connection** – Top of DC positive busbar connects to Magnum inverter’s DC positive terminal.
- DC3** **Battery Bank Negative Connection** – Bottom of DC shunt connects to the battery bank’s negative terminal.
- DC4** **Battery Bank Positive Connection** – Bottom of the inverter’s DC disconnect breaker connects to the battery bank’s positive terminal.
- DC5** **DC Grounding Electrode Connection** – The connection point for the MMP/inverter system to the DC grounding electrode. Use DC5A for greater than #1/0 AWG wires and DC5B for #6 to #1/0 AWG wires.
- DC6** **DC Equipment Grounding Connection** – The common DC equipment ground point for all DC equipment used in the MMP/inverter system.
- DC7** **PV Positive Connection** – Connects the positive output of a PV array and the positive input to the PV charge controller.
- DC8** **DC Negative Connection** – The battery negative common point for connecting additional DC circuits, such as from the DC negative output of a charge controller or combining the negatives of DC load circuit breakers.
- DC9** **Battery Positive Connection** – Serves as the battery positive connection point for additional DC circuits (from charge controller output or connecting to DC load breakers).



# Installation

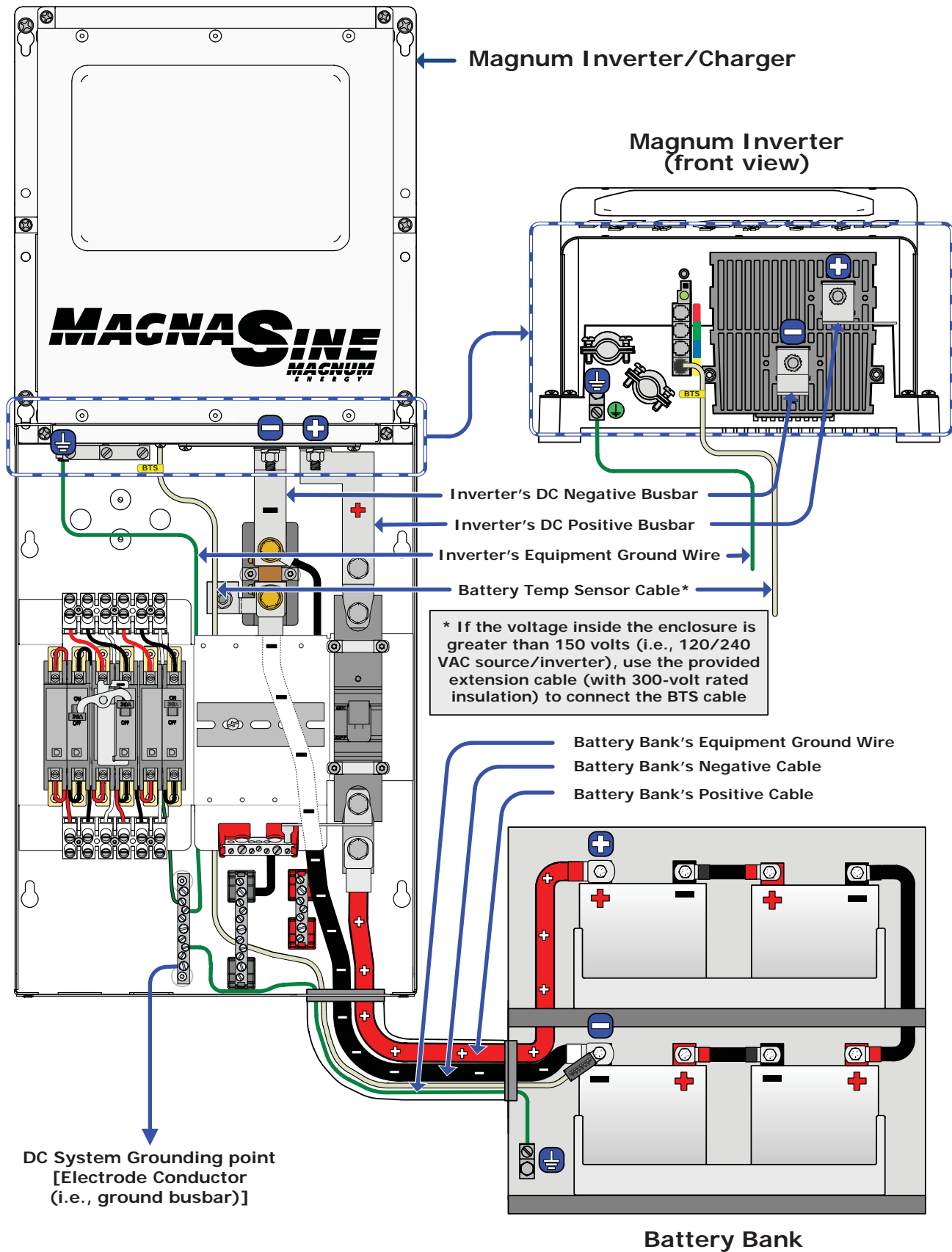


Figure 2-8, DC Wiring with Magnum Inverter



### 2.8.3 Inverter DC Overcurrent Protection and DC Disconnect

In a battery-based inverter system, the NEC/CEC assumes that each ungrounded conductor is connected to some source that supplies currents in excess of the ampacity rating of the conductor and could potentially damage that conductor under fault conditions. Because of this, the NEC/CEC requires that all ungrounded conductors in the inverter's DC system be protected by an overcurrent device, this can be either a circuit breaker or fuse. These breakers or fuses are not intended to protect equipment from damage, but protect the conductor/wire from overheating which may potentially cause a fire. This means the overcurrent device is required to open before the conductor reaches its maximum current carrying capability, thereby preventing a fire.



**Info:** Circuit breakers or fuses that are used on the DC side must be UL listed and DC rated for the application.

The NEC also requires the inverter system to have a DC disconnect switch to allow the inverter service providers to isolate the inverter from the battery. The disconnect must be either a DC rated circuit breaker or switch.

Depending on your model, the MMP enclosure is provided with either a 175-amp or 250-amp UL listed, high interruption capacity DC rated circuit breaker. These breakers are designed to interrupt the tremendous amount of current a battery can deliver when short-circuited. They are also specifically designed to have a long enough time delay to prevent the breaker from tripping, as the inverter requires high current levels when powering heavy loads.

When properly located and used with the minimum DC wire size shown in Table 2-4, these circuit breakers can provide the inverter system with both the DC overcurrent protection device and a safety disconnect switch.

### 2.8.4 Inverter and Battery Bank Wire Sizing

In a low voltage/high amperage system, it is important to use the correct DC wire to achieve maximum efficiency from the system and reduce fire hazards associated with overheating. Always keep your wire runs as short as practical to help prevent low voltage shutdowns and keep the DC breaker from nuisance tripping, because of increased current draw.

The size of the DC cables must be correctly sized according to the inverter's DC current requirements, DC breaker size, and the minimum voltage drop to the battery bank. If the DC circuit breaker provided in the MMP enclosure is being used as the inverter's DC overcurrent protection device, the cable size must not be less than the minimum DC wire size shown in Table 2-4.

Use Table 2-4 to select the minimum DC wire size based on your MMP model. These recommendations may not meet the inverter's continuous current requirements<sup>1</sup> or electrical code requirements.

**Table 2-4, Recommended DC Wire to MMP Enclosure**

MMP Model	DC Circuit Breaker	Minimum DC Wire Size (rating) <sup>2</sup>	DC Equipment Grounding Wire Size <sup>3</sup>
MMP175-30D	175 amps	#2/0 AWG (195 amps)	#6 AWG
MMP175-60S	175 amps	#2/0 AWG (195 amps)	#6 AWG
MMP250-30D	250 amps	#4/0 AWG (260 amps)	#4 AWG
MMP250-60S	250 amps	#4/0 AWG (260 amps)	#4 AWG



**WARNING:** If you use a battery or inverter cable smaller than the recommended minimum DC wire size for your MMP model (as shown in Table 2-4), you must install a fuse/circuit breaker compatible with this smaller cable to protect against a potential fire.

**Note<sup>1</sup>** – Refer to your inverter's owner's manual to determine the minimum DC wire requirements.

**Note<sup>2</sup>** – Wire must be copper with a minimum rating of 300V, 75°C at an ambient temperature of 30°C.

**Note<sup>3</sup>** – See Section 2.10 for more information on the equipment grounding wire size.

## Installation

### 2.8.5 DC Hardware Connections

Do not put anything between the DC cable lug and the DC terminals (i.e., on the DC circuit breaker, DC shunt, batteries, and inverter/busbars). Ensure the hardware used to hold these connections is stacked correctly. Incorrectly installed hardware causes a high resistance connection which could lead to poor inverter performance, and may melt the cable and terminal connections.

Follow Figure 2-9 to connect the DC cables and stack the hardware correctly.



**Info:** After making the battery connections and ensuring they are properly torqued, cover the outside of the connection with petroleum jelly or an antioxidant grease/spray. Do not put jelly/anti-corrosion grease between the terminal and the battery cable.

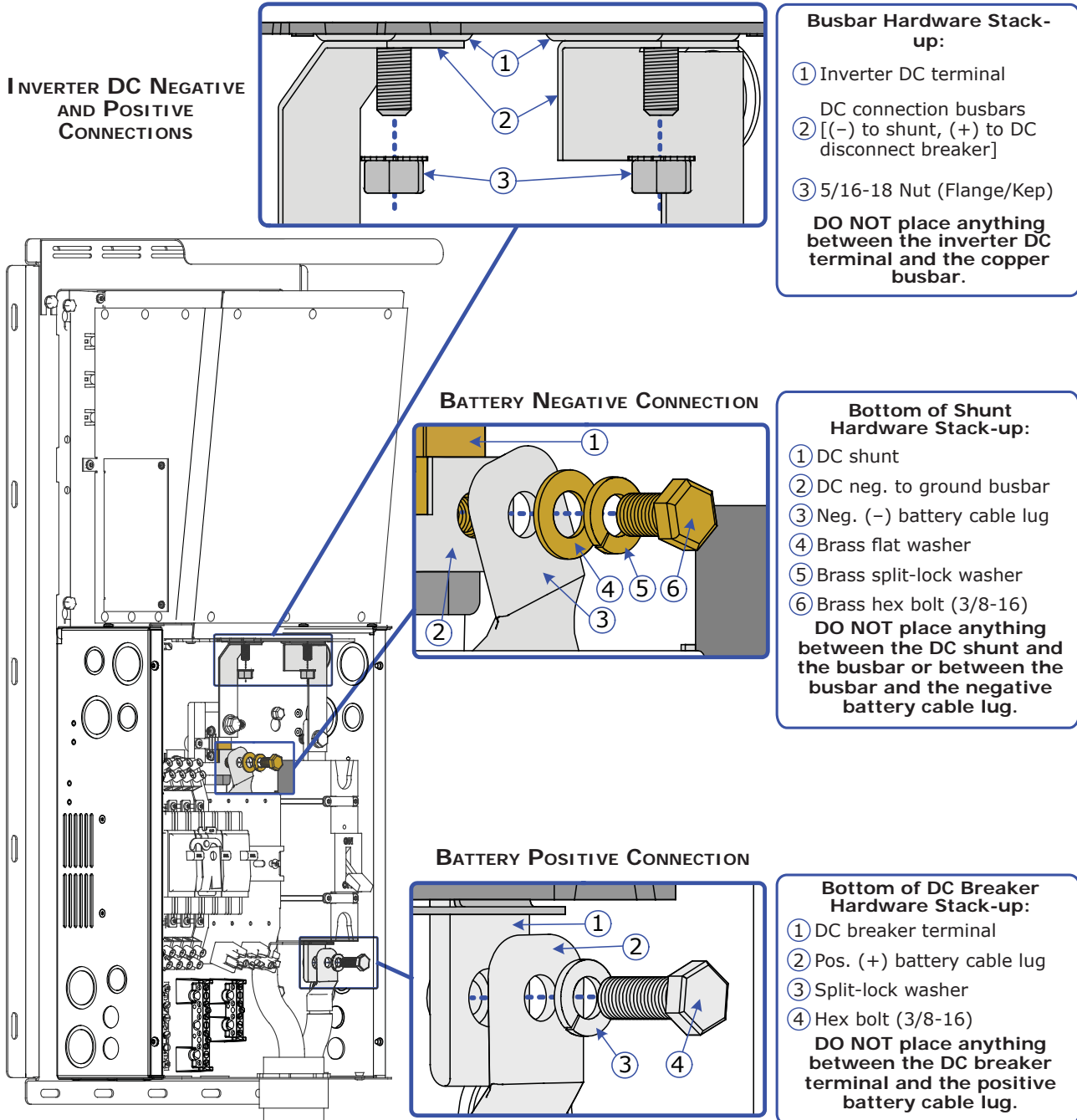


Figure 2-9, DC Connections – with Magnum Inverter Installed

### 2.8.6 Wiring the Battery Bank

Depending upon the voltage of the batteries you use in the installation (6 or 12 VDC), the batteries must be wired in series, parallel, or series-parallel to provide the correct voltage. The interconnecting DC wires should be sized and rated exactly the same as those that are used between the battery bank and the inverter.

Place the batteries as close as practical to the MMP enclosure/inverter system, preferably in an insulated and ventilated enclosure. Allow adequate space above the batteries to access the terminals and vent caps (as applicable). Also allow at least one inch of space between the batteries to provide good air flow. DO NOT mount the batteries directly under the MMP enclosure/inverter system.



**Info:** To ensure the best performance from your MMP enclosure/inverter system, batteries should be of the same size, type, rating, and age. Do not use old or untested batteries.

### 2.8.7 Wiring the MMP Enclosure to the Battery Bank/Inverter



**WARNING:** Ensure that all AC and DC breakers are switched OFF before connecting or disconnecting the battery cables, and that all sources of power (both AC and DC) are disconnected from the inverter.



**WARNING:** Lethal currents will be present if the positive and negative cables attached to the battery bank touch each other. During the installation and wiring process, ensure the cable ends are insulated or covered to prevent touching/shorting the cables.



**CAUTION:** DO NOT connect the DC wires to the battery bank until: 1) all DC, AC, and accessory wiring are completed, 2) the correct DC and AC overcurrent protection have been installed and, 3) the correct DC voltage and polarity have been verified.



**CAUTION:** The Magnum inverter is NOT reverse polarity protected, if this happens the inverter will be damaged and will not be covered under warranty. Before making the final DC connection from the batteries up to the inverter, verify the correct battery voltage and polarity by using a voltmeter. If the positive (+) terminal of the battery is connected to the negative (-) terminal of the inverter and vice versa, severe damage will result. Ensure the cables are color-coded to avoid polarity confusion.

This section describes how to make DC connections between your Magnum inverter/charger and the MMP enclosure, and the DC connections from the MMP enclosure to the batteries (using battery cables provided by the installer – see Table 2-4).

1. Place the Magnum inverter onto the top of the MMP enclosure, ensuring the inverter's DC terminals fit through the holes in the pre-installed DC positive and negative busbars within the MMP enclosure.
2. Route the DC cables from the battery bank—with the cables not connected to the battery—and connect them to the MMP enclosure; negative (-) to the bottom side of the DC shunt, positive (+) to the bottom side of the DC breaker. Be careful to observe proper polarity.
3. Ensure the DC wire connections (on the batteries, inverter, DC circuit breaker, and DC shunt) are flush on the surface of the DC terminals and the hardware used to hold these connections are stacked correctly (see Figure 2-9); and then securely tighten these DC connections. Only after the entire installation is complete and all connections are verified should the DC circuit breaker be closed to provide power to the inverter.
4. Route an appropriately sized DC grounding wire (green or bare wire) from the inverter's DC equipment ground terminal and from the battery bank enclosure to the DC ground busbar in the MMP enclosure. Refer to Section 2.10 for grounding information and sizing the DC ground wires.

### 2.9 AC Wiring

This section provides information on the AC wiring inside the MMP enclosure to/from the inverter, from the incoming AC source, and to the outgoing AC distribution panel (i.e., inverter sub-panel).

#### 2.9.1 AC Wiring Guidelines



**CAUTION:** Before installing any AC wiring, review the safety information at the beginning of this manual and below to ensure a safe and long-lived system:

- Read all instructions and cautionary markings located at the beginning of this manual and in the Installation section, before installing the inverter and batteries.
- AC wiring must be no less than #10 AWG (5.3 mm<sup>2</sup>) gauge copper wire and be approved for residential wiring.
- DO NOT connect the Magnum inverter's output to an AC power source. This could cause severe damage to the inverter and is not covered under warranty.



**WARNING:** To reduce the risk of fire, do not connect a 120 VAC only inverter to both busbars in an AC load center (circuit breaker panel) having multi-wire branch circuits connected. Every circuit connected to a 120 VAC panel must have its own neutral; otherwise, currents on shared neutrals will add rather than subtract, overloading the neutral conductor.

#### 2.9.2 AC Connections

Use either Figure 2-10 (for MMPxxx-30D models) or Figure 2-11 (for MMPxxx-60S models) to view the AC connection points inside the MMP enclosure.

##### 2.9.2.1 AC Input/Output Connections

The MMP enclosure provides two AC terminal blocks that allow the AC input and output wiring to be easily and permanently wired. These terminal blocks allow a service/distribution panel (main panel) to be wired to the inverter's input, and a dedicated inverter panel (sub-panel)<sup>1</sup> to be wired between the inverter's output wiring and the AC loads.

Depending on your MMP model, it will either have two six-pole AC terminals (Figure 1-2, Items 4 and 6), or two four-pole AC terminals (Figure 1-4, Items 4 and 6). The six-pole terminals are provided on the MMPxxx-30D models to allow 120/240 VAC inverters—up to 30 AC amps per leg pass-thru capability—to be connected. The four-pole terminals are provided on the MMPxxx-60S models to allow 120 VAC inverters—up to 60 AC amps pass-thru capability—to be connected.

The upper AC terminal block—INVERTER AC TERMINAL BLOCK—provides the connection points for the inverter's input and output Hot and Neutral connection points. The lower AC terminal block—EXTERNAL AC TERMINAL BLOCK—provides the Hot and Neutral connection points for the incoming utility/AC generator input and to the inverter AC sub-panel (if needed)<sup>1</sup>.



**Info:** The neutrals on the INVERTER AC TERMINAL BLOCK are NOT connected together. You must provide both an inverter input and output neutral connection to the inverter's AC terminal unless the inverter has the input and output neutrals connected together.

Each connection on the AC terminal block is rated to accept one #14 to #6 AWG (2.1 to 13.3 mm<sup>2</sup>) CU stranded wire, or, two #12 AWG (3.3 mm<sup>2</sup>) CU stranded wires. Each connection uses a M3.5 slotted screw, and the maximum tightening torque is 16 lbf-in (1.8 N-m).

##### 2.9.2.2 AC Ground Connections

The MMP enclosure comes with a ground busbar (Item 8, in Figure 1-2 or 1-4) to allow the AC grounds to be connected to a common point. This busbar has three #14 to #1/0 AWG and six #14 to #6 AWG screw type compression terminals. See Table 2-1 for torque requirements.



**CAUTION:** A neutral to ground connection is provided in the MMP enclosure. If this neutral-ground connection is provided elsewhere in the AC system, this connection must be disconnected. See Section 2.11 for information to disconnect this connection.

**Note**<sup>1</sup> – MS2012/MS2000 (-15B and -20B) breaker models do not require a dedicated inverter sub-panel.

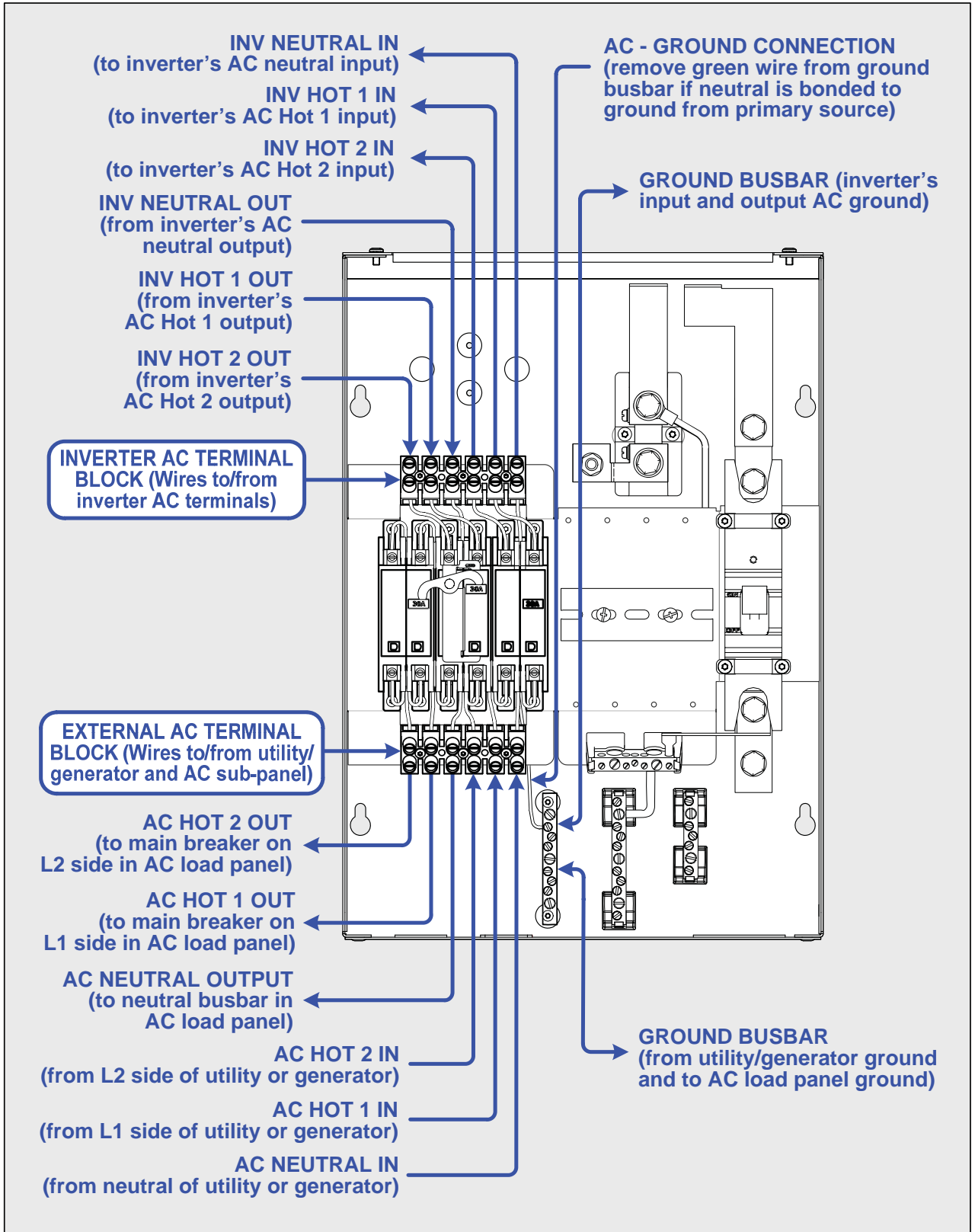


Figure 2-10, AC Wiring Connections (MMPxxx-30D Models)

## Installation

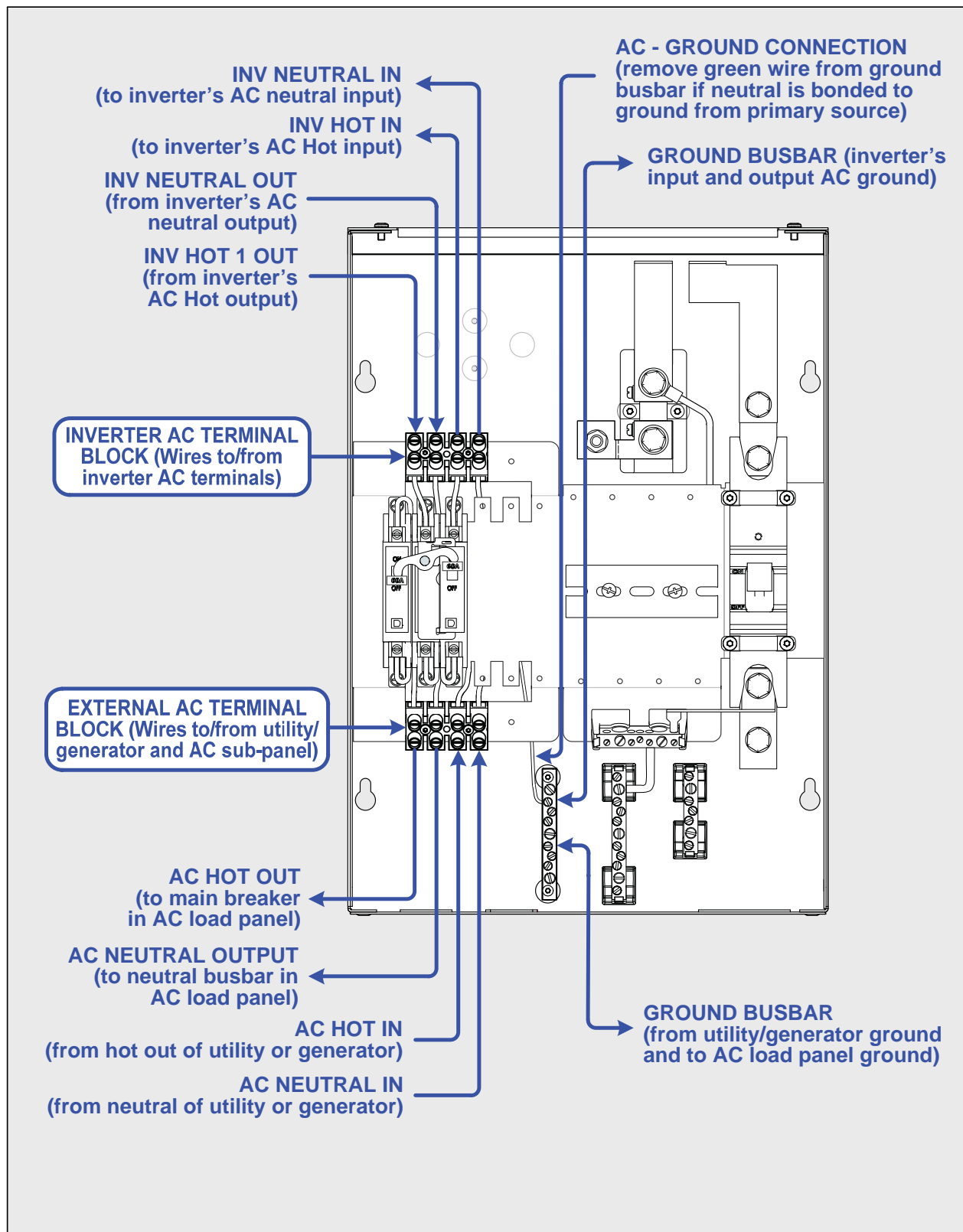


Figure 2-11, AC Wiring Connections (MMPxxx-60S Models)



### 2.9.3 AC Wire Size and Overcurrent Protection

The AC input and output wiring must be sized per the local electrical safety code requirements to ensure the wire's ability to safely handle the inverter's maximum load current. After determining the proper AC wire sizes, they are required to be protected from short circuits and overloads by an overcurrent protection device, and have a means to disconnect the AC circuits.

The MMP enclosure provides AC circuit breakers for the inverter's AC input. These breakers are branch circuit rated and can be used as the overcurrent protection and the AC disconnect device. This is true as long as the AC wires used are not smaller than the minimum wire size as shown in Table 2-5 for your particular MMP model, and the 'AC Input/Output Wiring Configuration' used. If using a Magnum MS, MS-AE, MS-PAE, or RD Series inverter, the full AC continuous pass-thru capacity of these inverters is 30 amps for each AC leg<sup>1</sup> (AC HOT 1 and AC HOT 2), and requires a maximum 30-amp breaker on each AC input to protect the inverter's inputs. This correlates with the MMPxxx-30D models, which include a dual 30-amp input inverter breaker and requires a minimum cable size of #10 AWG<sup>2</sup> in conduit.

In the MS or RD Series inverters, the AC HOT 1 and AC HOT 2 may be combined to obtain 60 amps pass-thru capability. When tying the AC HOT 1 and HOT 2 together for a 60 amp continuous pass-thru capability, the AC input to the inverter requires a 60-amp breaker. This correlates with the MMPxxx-60S models, which include a single 60-amp breaker and requires a minimum cable size of #6 AWG<sup>2</sup> in conduit. If you are using other circuit breakers/wire sizes, refer to the appropriate electrical codes for proper sizing requirements.

### 2.9.4 AC Conductor Wiring

The following steps are basic guidelines for installing and connecting the AC wiring into and out of the inverter. Refer to Table 2-5 to determine your AC wiring configurations before beginning.



**WARNING:** To prevent electrical shock, make sure all AC power (inverter, generator, or utility) is off before making any AC connections inside the MMP enclosure.

#### Wiring External AC Source and AC Load Panel

1. Route an appropriate cable from a dedicated breaker in the main AC electrical panel through one of the MMP enclosure's knockouts to the EXTERNAL AC IN/OUT TERMINAL BLOCK (HOT IN/NEUT IN side).
2. Route an appropriate cable from the EXTERNAL AC IN/OUT TERMINAL BLOCK (HOT OUT/NEUT OUT Side) through another MMP enclosure knockout to the inverter's AC electrical sub-panel (or AC outlets, if using the Magnum inverter models with output breakers).

#### Wiring Inverter AC Input/Output

1. Route an appropriate cable from the INVERTER AC IN/OUT TERMINAL BLOCK (HOT IN/NEUT IN side) to the inverter's AC input terminals.
2. Route an appropriate cable from the INVERTER AC IN/OUT TERMINAL BLOCK (HOT OUT/NEUT OUT side) to the inverter's AC output terminals.

#### Wiring the AC Ground

Route the following AC ground wires; 1) the main AC panel's ground busbar, 2) the ground wire from the inverter's AC sub-panel's ground busbar (or the ground connection on the outlets, if using the Magnum inverter with output breakers), and 3) the AC ground wire from the inverter; and connect to the GROUND busbar in the MMP enclosure (Item 8 in Figures 1-2 and 1-4).

#### AC Wiring Inspection

After verifying all AC connections are correct, and all AC terminal screws are torqued correctly (refer to Tables 2-1 to 2-3), replace the inverter's AC wiring access cover and the covers on the main electrical panel/sub-panel.

**Note<sup>1</sup>** – On Magnum MS2012/MS2000 (-15B and -20B) breaker models, the pass-thru current is limited by the output breaker size.

**Note<sup>2</sup>** – This wire must be copper with a minimum rating of 300V, 75°C.



## Installation

### 2.9.5 AC Wiring Configurations

The following table provides the different wiring configurations for installing and connecting the AC conductors into and out of the inverter (refer to Figures 2-12 to 2-15 for installation drawings showing these configurations).

**Table 2-5, AC Input/Output Wiring Configurations**

	<b>SI/SO (30A) [Single In/ Single Out (30A)]</b>	<b>SI/SO (60A) [Single In/ Single Out (60A)]</b>	<b>DI/SO [Dual In/ Single Out]</b>	<b>DI/DO [Dual In/ Dual Out]</b>
<b>AC Source<sup>1</sup> Required</b>	120 VAC @ ≤ 30 amps	120 VAC @ > 30 amps (60 amps maximum)	120/240 VAC (or two separate legs of 120 VAC) @ ≤ 30 amps per leg	120/240 VAC (or two separate legs of 120 VAC) @ ≤ 30 amps per leg
<b>Reason to Use</b>	Have a 120 VAC source that is ≤ 30 amps. Requires a separate inverter sub-panel <sup>4</sup> .	Have a 120 VAC source that is > 30 amps. Requires a separate inverter sub-panel.	Want dedicated charging and dedicated pass-thru while the AC source is on. Requires a separate inverter sub-panel.	May need to power 240 VAC loads when AC source is on (requires 120/240 VAC source). Requires a separate inverter sub-panel.
<b>Appropriate MMP Models</b>	<b>MMP175-30D, MMP250-30D</b>	<b>MMP175-60S, MMP250-60S</b>	<b>MMP175-30D, MMP250-30D</b>	<b>MMP175-30D, MMP250-30D</b>
<b>Appropriate Magnum Inverter Models</b>	MS Series, MS-AE Series, MS-PAE Series, RD Series	MSxx12, MS4024, MS-AE Series, MS-PAE Series, RD Series	MSxx12, MS4024, RD Series	MSxx12, MS4024, MS-AE Series, MS-PAE Series, RD Series
<b>AC Input Breaker Provided</b>	30A (one pole of dual pole breaker)	60A (single pole)	30A (dual pole)	30A (dual pole)
<b>Minimum AC Wire Size<sup>5</sup></b>	#10 AWG (In & Out)	#6 AWG (In & Out); Can be split to two #10 AWG (for HOT 1 & HOT 2)	#10 AWG (In & Out)	#10 AWG (In & Out)
<b>Maximum Inverter Pass-thru Capacity</b>	3600W (30A @ 120 VAC)	5000W <sup>2</sup> (60A @ 120 VAC)	3600W (30A @ 120 VAC)	5000W <sup>2</sup> (two legs of 30A @ 120/240 VAC or two legs of 30A @ 120 VAC) <sup>3</sup>
<b>Wiring Diagram</b>	Figure 2-12	Figure 2-13	Figure 2-14	Figure 2-15

**Note<sup>1</sup>** – AC Source is from either the utility/grid power or an AC generator.

**Note<sup>2</sup>** – Enclosure capacity rated for 5000 Watts maximum.

**Note<sup>3</sup>** – If two legs of 30A @ 120 VAC are used, they must be from the same source.

**Note<sup>4</sup>** – The MS2012 and MS2000 models with integral branch circuit rated output breakers (i.e. MS2012-20B) allows direct wiring from the unit to the load and do not require an inverter sub-panel.

**Note<sup>5</sup>** – Based on AC input breaker provided.

**SINGLE IN / SINGLE OUT (30A)  
AC Wiring**

**MMPxxx-30D Enclosure  
(with Magnum Inverter)**

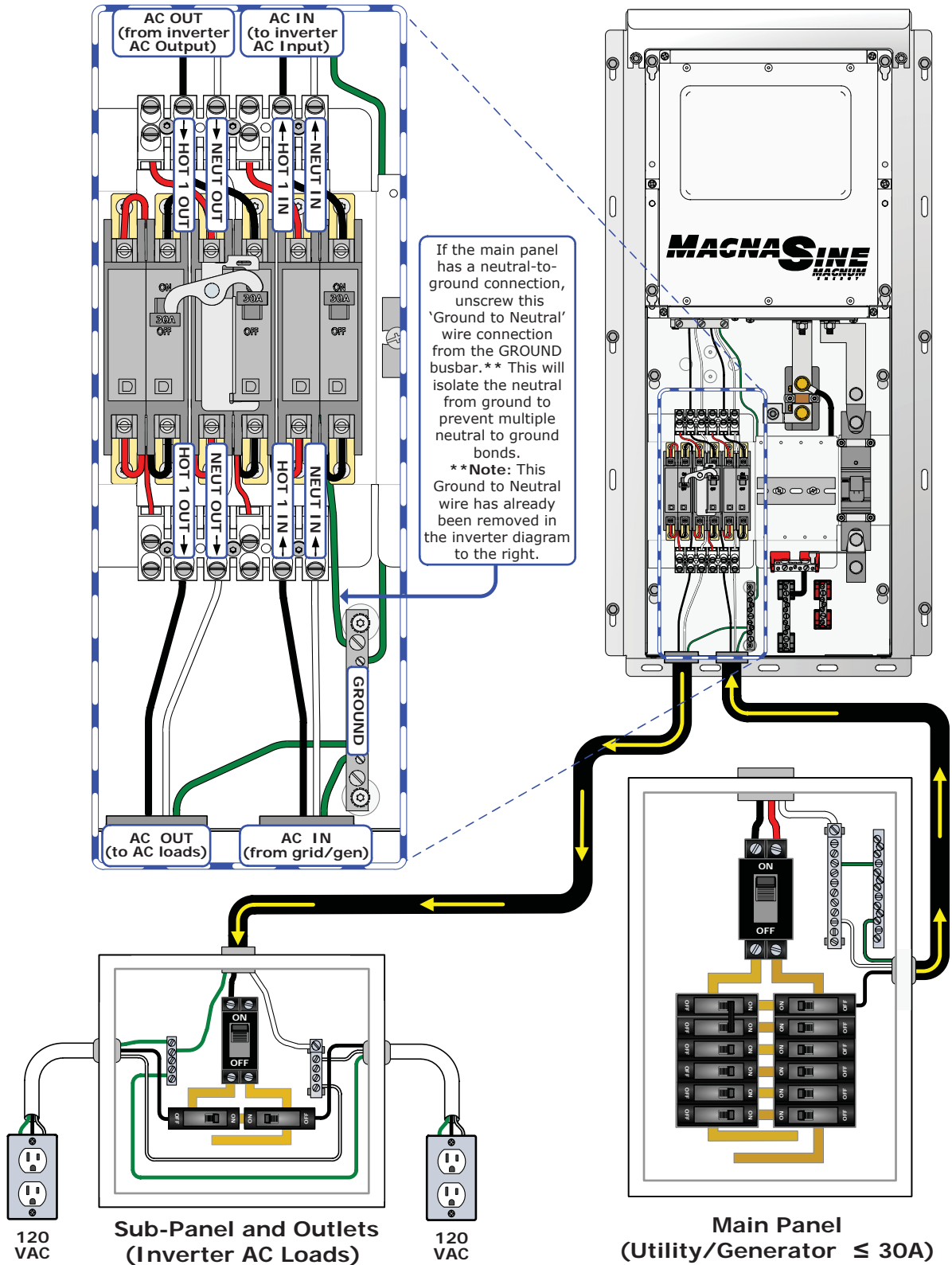
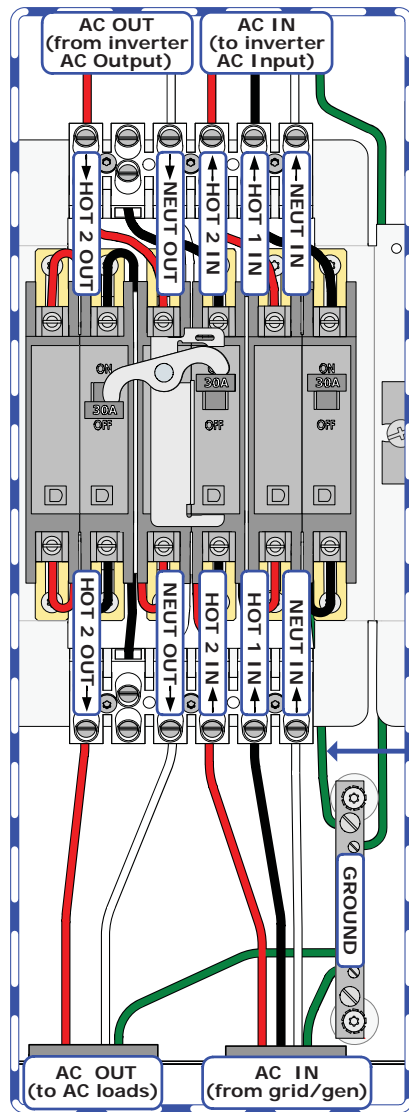


Figure 2-12, AC Wiring for Single In – Single Out (30 A) Configurations



DUAL IN / SINGLE OUT  
AC Wiring



MMPxxx-30D Enclosure  
(with Magnum Inverter)

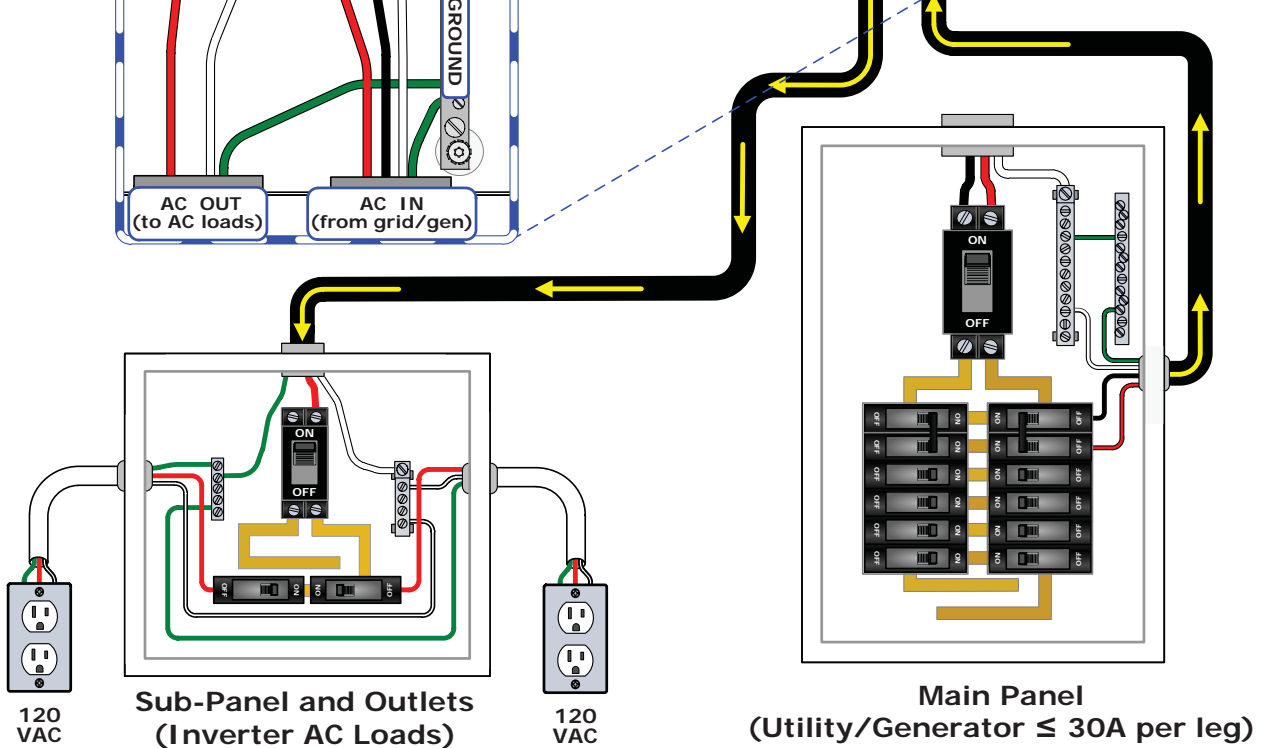
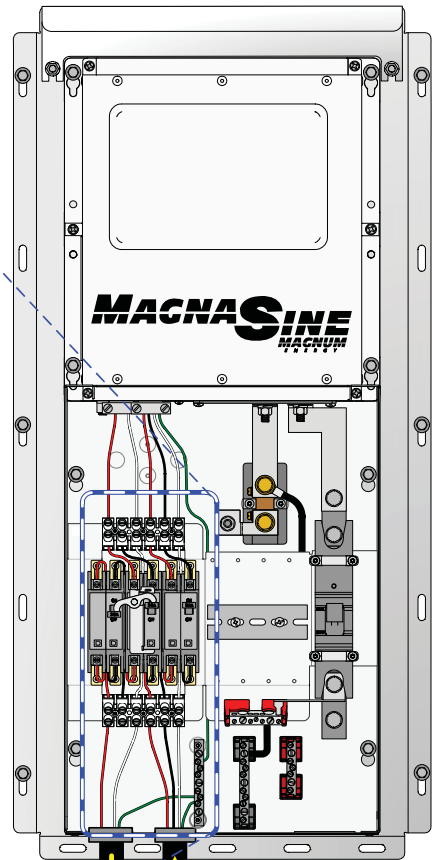


Figure 2-14, AC Wiring for Dual In – Single Out Configurations



## 2.10 MMP/Inverter System Grounding

The MMP/inverter system uses both AC and DC electrical systems, therefore **each** electrical system is required to be properly connected to a permanent, common “ground” or “earth” reference. A MMP/inverter system that is properly grounded limits the risk of electrical shock, reduces radio frequency noise, and minimizes excessive surge voltages induced by lightning. To understand how the conductors in the electrical circuit will be connected to the system ground, the following terms should be understood (also refer to Figure 2-16):

- **Grounded Conductor (GC):** The wire/cable in the electrical system that normally carries current (usually the AC neutral and/or the DC negative), and is intentionally connected or “bonded” to the ground system. This wire or the ends of this wire must be colored white or gray.
- **Equipment Grounding Conductor (EGC):** A wire/cable that does not normally carry current and is used to connect the exposed metal parts of equipment—that might be accidentally energized—to the grounding electrode system or the grounded conductor. This wire or the ends of this wire must be green, or green with a yellow stripe; or, this wire can be bare copper.
- **Grounding Electrode Conductor (GEC):** The wire/cable that does not normally carry current, and connects the grounded conductor and/or the equipment grounding conductor to the grounding electrode at the service equipment.
- **Grounding Electrode (GE):** A ground rod or conducting element that establishes an electrical connection to the earth or common ground reference.
- **System bonding jumper (SBJ):** The connection between the grounded circuit conductor in the electrical system and the equipment grounding conductor at a separately derived system.

There are two types of grounding – equipment grounding and system grounding.

The exposed metal parts of the equipment in the system usually don’t carry electricity. However, if the exposed metal becomes electrified by a live wire, a person touching this live part could complete the electrical circuit and receive a shock. Equipment grounding prevents shock by connecting all the exposed metal parts of equipment (via Equipment Grounding Conductors – EGC) together at a common ground point (Ground BusBar – GBB). This common ground point—installed in the service disconnect panel for each electrical system (AC and DC)—is then connected (via Grounding Electrode Conductor – GEC) to the common ground reference, such as a ground rod (Grounding Electrode – GE). This connection to earth is made at only one point in each electrical system; otherwise, parallel paths will exist for the currents to flow. These parallel current paths would represent a safety hazard and are not allowed in installations wired per the NEC/CEC.

System grounding takes one of the current carrying conductors (Grounded Conductor – GC) and attaches it to the common ground point (Ground BusBar – GBB), usually by a System Bonding Jumper (SBJ) in each electrical service disconnect panel. On the AC side, that is the neutral conductor (**GC-AC**); on the DC side, it’s the negative conductor (**GC-DC**). The closer the grounding connection is to the source, the better the protection from high voltage surges due to lightning.

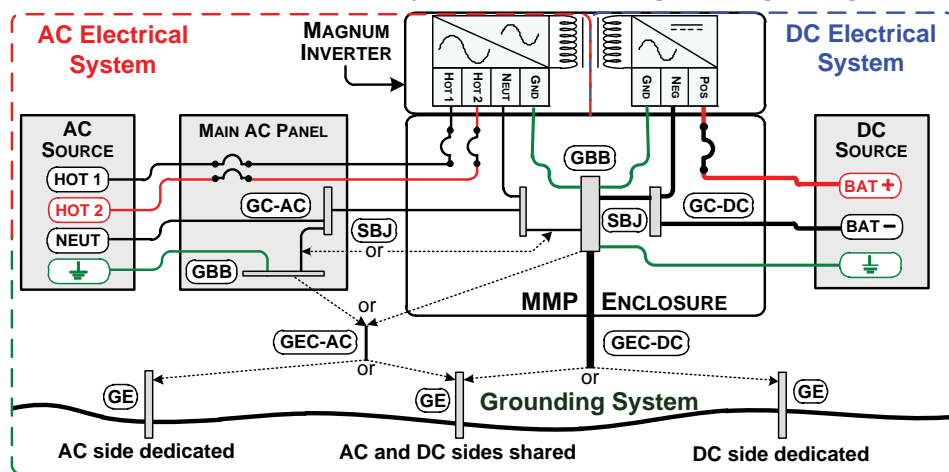


Figure 2-16, Grounding System for Inverter with MMP Enclosure



## Installation

### 2.10.1 Sizing the Grounding Electrode Conductors

**AC Side** – The size of the AC Grounding Electrode Conductor (GEC-AC) depends on the size of the largest ungrounded conductor feeding the AC load center. One #8 AWG (8.4 mm<sup>2</sup>) copper conductor will serve as an AC Grounding Electrode Conductor (GEC-AC) for AC power conductors smaller than and including #2 AWG (33.6 mm<sup>2</sup>) copper. See Table 2-6 for additional values.

**Table 2-6, AC Grounding Electrode Conductor Sizing**

Size of Largest Ungrounded Conductor	Minimum Size of Grounding Electrode Conductor
#2 AWG or smaller	#8 AWG (8.4 mm <sup>2</sup> )
#1 to #1/0 AWG	#6 AWG (13.3 mm <sup>2</sup> )
#2/0 or #3/0 AWG	#4 AWG (21.1 mm <sup>2</sup> )
Over #3/0 AWG through 350 kcmil	#2 AWG (33.6 mm <sup>2</sup> )

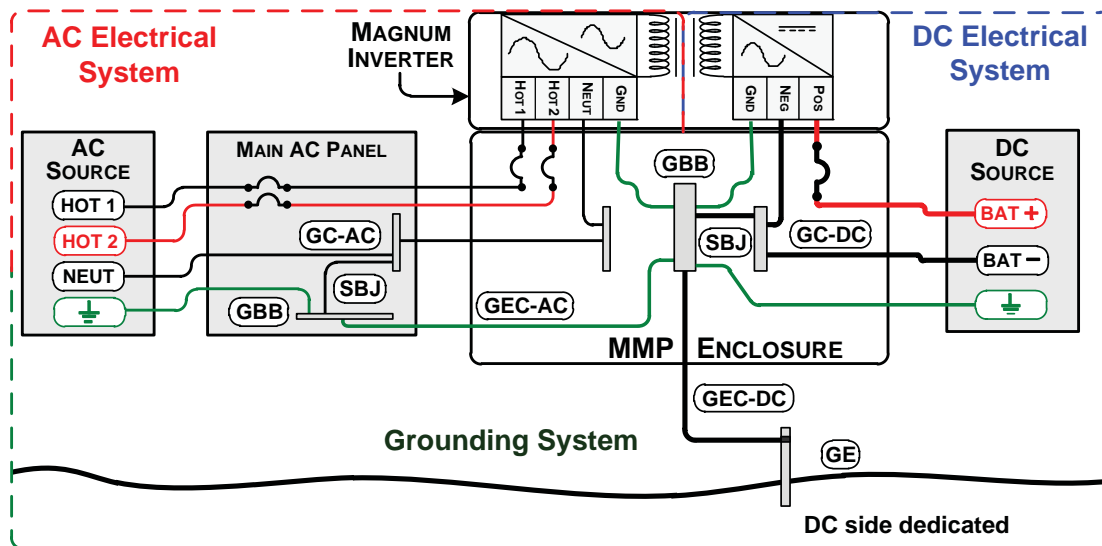
**DC Side** – To size the DC grounding electrode conductor, you must first determine which one of the following three methods will be used to connect the DC and AC grounding points in the inverter's two electrical systems to the common "earth" ground.



**Info:** There are many variables to consider when choosing the size of the DC grounding electrode conductor. The MMP enclosure provides the means to ground both the AC and DC to a single ground, and when feasible, the Single Connection to Ground (Method 1) is recommended. In this method, the NEC allows a #6 AWG wire which makes the overall installation simpler and less costly.

**1. Single Connection to Ground (Method 1):** The AC Grounding Electrode Conductor (GEC-AC) is bonded to the DC ground point and the DC Grounding Electrode Conductor (GEC-DC) is the *only connection* to the grounding electrode, which must be a rod, pipe, or plate electrode (see Figure 2-17).

Normally the size of the DC Grounding Electrode Conductor (GEC-DC) must be no less than the size of the Battery Bank Negative Cable. However, in this method, since there is only one connection to the ground rod, the NEC allows an exception that the DC grounding electrode conductor is not required to be larger than #6 AWG (13 mm<sup>2</sup>) copper. The reasoning for allowing this smaller grounding electrode conductor is that it is only required to stabilize the system voltage with respect to earth, and the other properly sized conductors in each electrical system will safely carry any fault currents if they occur.



**Figure 2-17, Single Connection to DC Ground Rod (Method 1)**



2. **Multiple Connections to Ground – Single Electrode (Method 2):** When the AC and DC service panels are near each other, then the AC Grounding Electrode Conductor (GEC-AC) and DC Grounding Electrode Conductor (GEC-DC) can be connected to a single Grounding Electrode (see Figure 2-18). In this method—since there are multiple connections to the DC Grounding Electrode (GEC-DC)—the size of the DC grounding electrode conductor cannot be smaller than the largest conductor in the DC system (usually the battery-to-inverter cable).

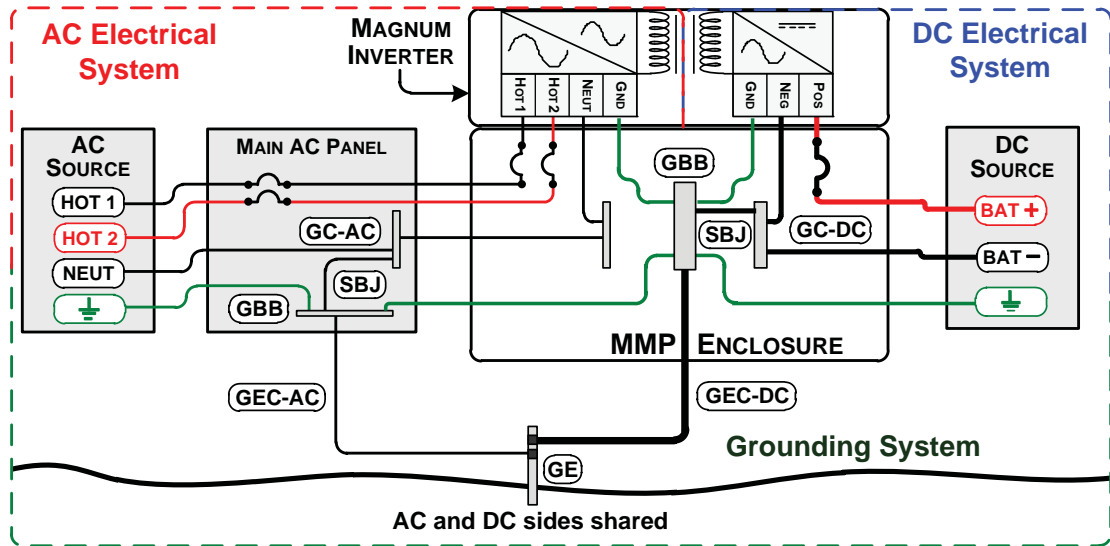


Figure 2-18, Multiple Connections to DC Ground Rod (Method 2)

3. **Multiple Connections to Ground – Multiple Electrodes (Method 3):** This method uses a separate grounding electrode for the DC system and the AC system (see Figure 2-19). In this method—since there are multiple connections to the DC Grounding Electrode (GEC-DC)—the size of the DC grounding electrode conductor cannot be smaller than the largest conductor in the DC system (usually the battery-to-inverter cable).

The DC Grounding Electrode (GE-DC) must be bonded to the AC Grounding Electrode (GE-AC) to make a grounding electrode system; this Bonding Conductor (BC) cannot be smaller than the largest grounding electrode conductor, either AC or DC.

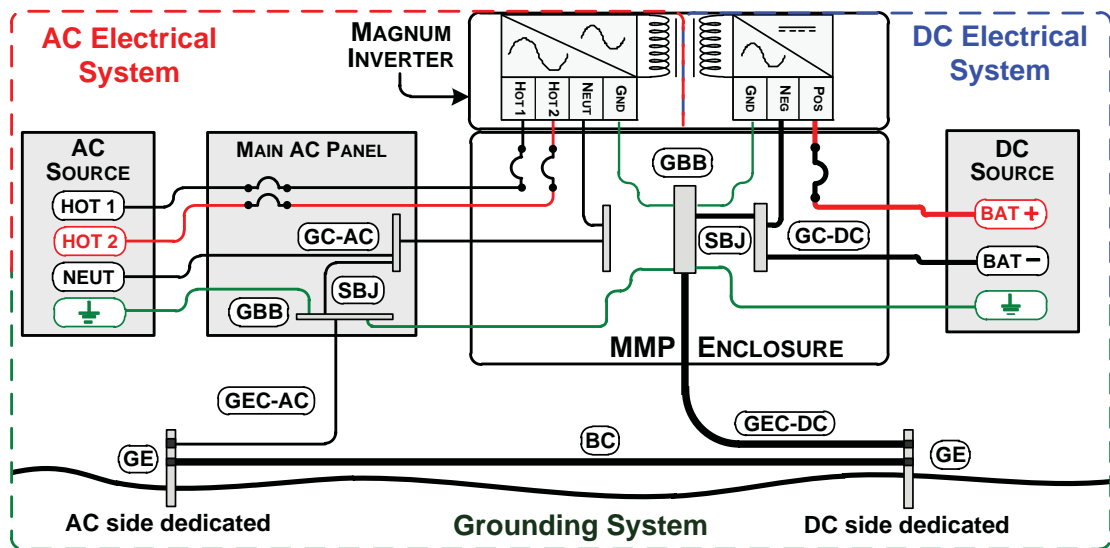


Figure 2-19, Multiple Connections to DC Ground Rod (Method 3)

## Installation

### 2.10.2 Equipment Grounding Conductor

The MMP enclosure and all other noncurrent-carrying exposed metal surfaces in the entire electrical system that may be accidentally energized must be grounded. The equipment-grounding conductor must be sized to safely carry the maximum ground-fault current likely to be imposed on it from where a ground-fault may occur.

**AC Side** – When the AC circuit breaker provided in the MMP enclosure is being used as the inverter’s AC overcurrent protection device, the AC Equipment Grounding Conductor (EGC-AC) for the inverter is based on the AC breaker size provided (#10 AWG for all MMP models). Connect the AC equipment-grounding conductor from the inverter’s AC ground connection to the Ground Busbar (GGB) in the MMP enclosure (Item 8 in Figure 1-2 or 1-4).

**DC Side** – When the DC circuit breaker provided in the MMP enclosure is being used as the inverter’s DC overcurrent protection device, the DC Equipment Grounding Conductor (EGC-DC) for the inverter is based on the DC breaker size provided (#6 AWG for MMP175 models, #4 AWG for MMP250 models). Connect the DC equipment-grounding conductor from the inverter’s DC ground connection to the Ground Busbar (GGB) in the MMP enclosure (Item 20 in Figure 1-2 or 1-4).

If you are using AC or DC overcurrent protection that is different than that provided in the MMP enclosure, or installing optional DC breakers inside the MMP enclosure, in accordance with the NEC/CEC you must determine your equipment-grounding conductors based on the ampere rating of the overcurrent device protecting the circuit conductors. Use Table 2-7 to help determine the equipment-grounding conductor. If the circuit conductors are oversized to compensate for voltage drop, the equipment-grounding conductor must also be oversized proportionally.

**Table 2-7, Equipment Grounding Conductor Sizing**

Rating of Overcurrent Device	Minimum Size of Copper Ground Wire
15 amp	#14 AWG
20 amp	#12 AWG
30-60 amp	#10 AWG
100 amp	#8 AWG
200 amp	#6 AWG
300 amp	#4 AWG
400 amp	#3 AWG

### 2.10.3 System Bonding Jumper

The MMP enclosure provides the single point of ground [System Bonding Jumper (SBJ)] for the AC and DC system. If the MMP enclosure is the central connection point for all ground wiring (usually in an off-grid system) and there is no other connection from AC neutral or DC negative to ground in the AC or DC system, then leave the ground bond connections in place. Remove any other neutral-ground connection in the AC system, such as in other electrical sub-panels; or, any negative-ground connection in the DC system.

For utility connected systems where the neutral and ground are already bonded in the main utility circuit breaker box (AC distribution panel), the GREEN GROUND/NEUTRAL bonding wire **MUST BE REMOVED** from the MMP enclosure. See Section 2.11 to remove this neutral-ground connection.



**Info:** Inverters and portable generators that have electrical outlets usually have the neutral and ground bonded internally. These types of devices are not recommended to be connected to the MMP/inverter system as they would first need to be modified to separate the neutral and ground bonding internally.

For systems or devices that connect the DC negative to ground independently (i.e., separate DC main electrical distribution panel or PV-GFP device), the Negative to Ground busbar (Item 1, Figure 1-2 or 1-4) **MUST BE REMOVED** inside the MMP enclosure. See Section 2.12 to remove this negative-ground connection.

## 2.11 Removing the AC Neutral to Ground Connection

In installations where the MMP enclosure is powered from utility power or large permanently installed generator systems, the AC neutral to ground connection is normally provided inside the main AC electrical distribution panel. In these systems, the factory installed neutral to ground connection in the MMP enclosure must be removed to prevent multiple neutral to ground bonds. See Figure 2-20 to help remove the neutral to ground connection from the AC Ground Busbar.

Steps to remove the neutral to ground connection:

1. Inside the MMP enclosure, locate the green wire with the NEUTRAL-GROUND CONNECTION label (Item 7, in Figure 1-2 or 1-4). This green wire connects the neutral and ground inside the MMP enclosure.
2. Loosen the screw and remove this green wire from the Ground Busbar (Item 8, in Figure 1-2 or 1-4). **Note:** After this wire is removed, remember to tighten the loose screw back into the busbar to prevent it from being lost.
3. With this green wire removed, wrap electrical tape around the bare end to insulate the wire and prevent it from making contact with any metal. Secure the green wire out of the way.

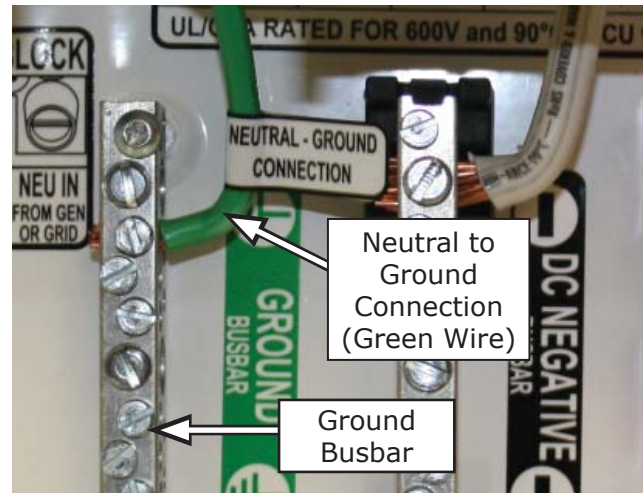


Figure 2-20, Removing the AC Neutral to Ground Connection

## 2.12 Removing the DC Negative to Ground Busbar

The MMP enclosure provides the single point of ground for the DC system by connecting the DC shunt (battery negative connection point) to the DC Ground Stud using the DC Negative to Ground Busbar (Item 1, in Figure 1-2 and 1-4). If the single negative-ground connection is made elsewhere in the DC system—either at the battery terminal, inside a charge controller, or if you are installing a PV-Ground Fault Protection (PV-GFP) device—this busbar must be removed to prevent multiple negative-ground bonds. See Figure 2-21 to help remove the Negative to Ground Busbar.

Steps to remove the DC negative-to-ground connection:

1. Inside the MMP enclosure, locate the Negative to Ground Busbar (Item 1, in Figure 1-2 and 1-4). This busbar connects negative and ground inside the MMP enclosure.
2. Remove the 5/16" flange nut (1/2" wrench) holding the busbar to the DC Ground Stud (Item 13, in Figure 1-2 or 1-4), and then remove the 3/8" brass bolt and washer (9/16" wrench) from the bottom terminal of the DC shunt (Item 12, in Figure 1-2 or 1-4).
3. After the Negative to Ground Busbar is removed; reattach the flange nut on the DC Ground Stud and the brass bolt/washer back onto the DC shunt. Ensure the hardware on the bottom terminal of the DC shunt is stacked correctly. **Note:** Refer to Figure 2-9 to correctly stack the DC shunt hardware.

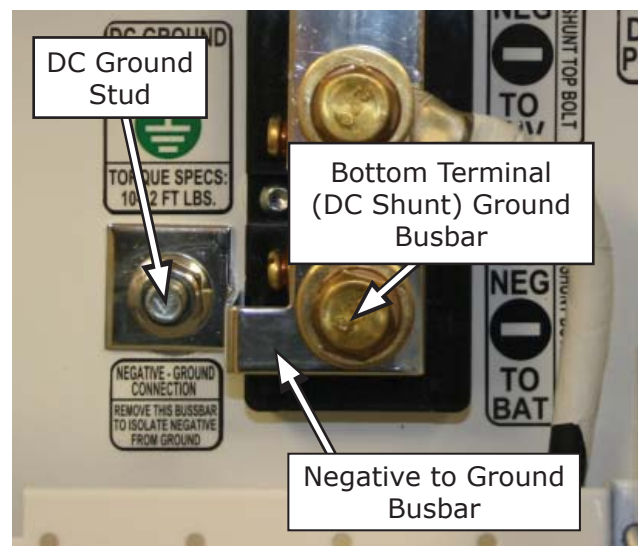


Figure 2-21, Removing the DC Negative to Ground Busbar

## Installation

### 2.13 Wiring Accessories

The NEC/CEC requires the insulation of all conductors inside the MMP enclosure to be rated for the highest voltage present. The MMP enclosure is designed to work with 120/240 VAC inverters, therefore, the voltage rating of the communications cables inside the MMP enclosure must be rated for 300 volts or higher to be code compliant.

With the purchase of the MMP enclosure, Magnum has included three six-foot, yellow communication cables with 300-volt rated insulation. These cables—shown below—are provided to make connections between Magnum inverters and accessories easier and code compliant.



**Info:** These cables carry less than 30 volts and are thus considered a “limited energy circuit”, which is normally not required to be installed in conduit.

Figure 2-22 shows the ‘REMOTE’ cable. It allows a remote control—such as the ME-RC (Remote Control) or ME-ARC (Advance Remote Control)—to be connected to the MMP enclosure. This cable is a 6’ (1.83m), 4-conductor, telephone-type cable with a RJ14 (m) connector and a blue REMOTE label on each end. One end of this cable is connected to the remote, and the other end is routed inside the MMP enclosure and then connected to the inverter’s REMOTE port as shown in Figure 2-25.



**Figure 2-22, REMOTE Communication Cable (300V)**

Figure 2-23 shows the ‘NETWORK’ cable. It allows Magnum accessories—like the ME-AGS (Auto Generator Start) or ME-BMK (Battery Monitor)—to be connected to the MMP enclosure. This cable is a 6’ (1.83m), 2-conductor, telephone-type with a RJ14 (m) connector and a green NETWORK label on each end. One end of this cable is connected to the accessory, and the other end is routed inside the MMP enclosure and then connected to the inverter’s NETWORK port as shown in Figure 2-25.



**Figure 2-23, NETWORK Communication Cable (300V)**

Figure 2-24 shows the ‘EXTENSION’ cable. It allows the Magnum ME-BTS (Battery Temperature Sensor) to be connected to the MMP enclosure. This is a 6’ (1.83 m), 4-conductor, telephone-type cable with a RJ14 (m) connector on one end and a RJ14 (f) plug on the opposite end. The female plug end connects to the ME-BTS (Battery Temperature Sensor). After connecting to the ME-BTS, this extension cable is routed inside the MMP enclosure and connects to the inverter’s BTS port as shown in Figure 2-25.



**Figure 2-24, Extension Cable (300V)**

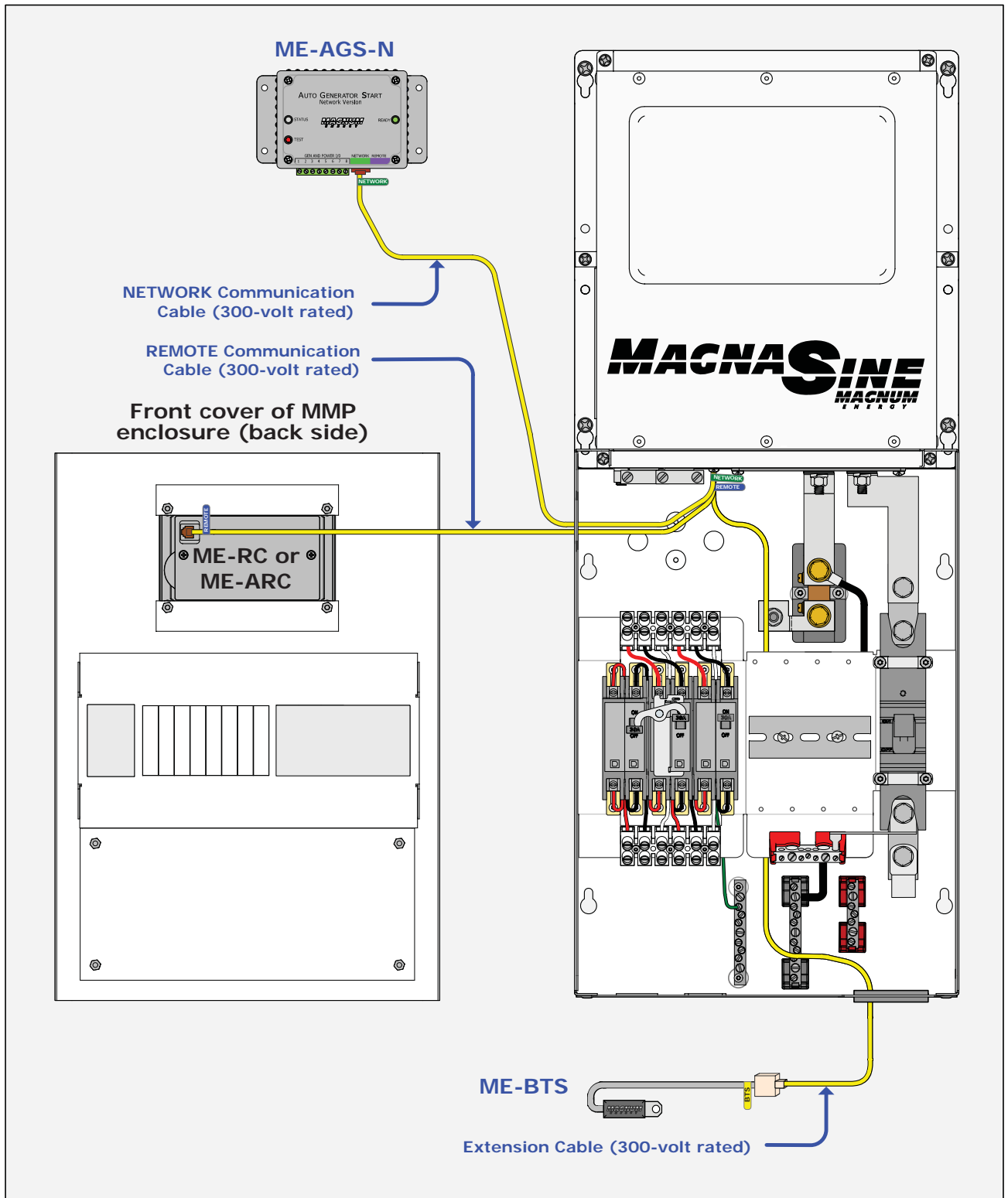


Figure 2-25, Accessory Wiring using 300 Volt Communications Cables



## Installation

### 2.14 Installation Checklist

Use this checklist as a final review to ensure all essential steps to install the MMP enclosure have been completed before proceeding with the functional test.

#### Mounting

- The MMP enclosure/inverter system is securely mounted in a clean, dry, and ventilated area.
- The system is not mounted in the same enclosure as maintenance-free or vented type batteries.
- The MMP enclosure is mounted in a 'vertical only' position.
- There is adequate clearance to access the front and to view/adjust the remote (if installed).

**DC Wiring** (use Table 2-4 to determine the DC wire size).

Inverter Side with Magnum Inverter (see Figure 1-2, Items 9A & 10A):

- The inverter is correctly placed onto the MMP enclosure with the inverter's DC terminals attached to the tops of the DC negative busbar and the DC positive busbar inside the MMP enclosure.

Inverter Side without Magnum Inverter (see Figure 1-2, Items 9B & 10B):

- An appropriately sized DC cable is routed and attached from the inverter's DC positive (+) terminal to the DC positive connection at the top of the DC breaker inside the MMP enclosure.
- An appropriately sized DC cable is routed and attached from the inverter's DC negative (-) terminal to the DC negative connection at the top of the DC shunt inside the MMP enclosure.

Battery Bank Side (see Figure 2-8):

- An appropriately sized DC cable is routed and attached from the positive (+) battery terminal to the bottom battery bank connection of the DC disconnect breaker inside the MMP enclosure.
- An appropriately sized DC cable is routed and attached from the negative (-) battery terminal to the bottom battery bank connection of the DC shunt inside the MMP enclosure.
- The DC cable connections and DC hardware are stacked (Figure 2-9) and torqued (Tables 2-1 to 2-3) correctly.

**AC Wiring** (use Table 2-5 to determine the AC wiring configuration and to find the AC wire size).

In and Out of Inverter (see Figures 2-10 & 2-11):

- The AC wires are appropriately sized and routed from the INVERTER AC TERMINAL BLOCK (inside MMP enclosure) to the inverter's AC input/output terminals.

To Main AC Electrical Panel (see Figures 2-12 to 2-15):

- The AC wires are appropriately sized and are routed from the grid/gen side of the EXTERNAL AC TERMINAL BLOCK (inside MMP enclosure) to the circuit breaker in the main AC electrical panel powered by the utility or generator (i.e., main panel).

To Inverter AC Load Panel (see Figures 2-12 to 2-15):

- The AC wires are appropriately sized and are routed from the AC load side of the EXTERNAL AC TERMINAL BLOCK (inside MMP enclosure) to the main circuit breaker in the electrical panel powered by the inverter (i.e., sub-panel).
- The AC wires connected to the terminal blocks are torqued correctly (see Tables 2-1 to 2-3).

#### Grounding

- There is only one bonding connection to ground for the DC electrical system (negative to ground) and one bonding connection to ground for the AC electrical system (neutral to ground). These bonding connections may be connected to the same grounding electrode system (ground rod). If separate electrodes are used, they must be bonded together.
- The exposed metal parts of equipment are properly grounded.
- Equipment grounding conductors are properly sized.

#### Electrical Connections

- Connectors are listed for the intended use and environment (inside, outside, wet, etc.,).
- Pressure/screw terminals tightened to the recommended torque specification.
- Terminals containing more than one conductor are listed for multiple conductors.
- Connectors using flexible, fine-stranded conductors are listed for use with such conductors.
- Re-torque electrical terminal connections in the inverter that may have loosened.

### Conductors and General Wiring Methods

- Conductors are rated for the application and the environment.
- Standard building-wire conductors and appropriate wiring methods are used.
- Note:** *Welding, marine, locomotive (DLO), and auto battery cables don't meet NEC/CEC requirements. Flexible RHW or THW cables are available, but these cables require very limited, specially listed terminals. When the battery conductors leave the battery enclosure, the conductors must be of a type listed for use in conduit (RHW or THW).*
- The DC and AC color codes for the ground conductors are the same – grounded conductors are white and equipment-grounding conductors are green, green/yellow, or bare (no insulation).
- All wiring insulation must have a minimum rating of 150V, 75°C when using only 120 VAC power/inverter; or, with a minimum rating of 300V, 75°C when using 120/240 VAC power/inverter.
- Strain reliefs/cable clamps or conduit are used on all cables and cords.
- Conductors between the inverter and battery bank are required to be installed in conduit.
- No multi-wire branch circuits when single, 120 VAC inverters are connected to 120/240 VAC load centers.

**Note:** *A multi-wire branch circuit is a three-wire circuit with a shared neutral for two, 120 VAC branch circuits.*

### Overcurrent Protection

- Properly sized and rated disconnects and overcurrent devices are used in the ungrounded conductors in each circuit (AC and DC).
- Overcurrent devices in the DC circuits are listed for DC operation.
- DC overcurrent protection is provided at the batteries when they are located in a separate room, or more than five feet away from the MMP enclosure.
- The DC overcurrent protection device and battery cables to the inverter are sized for the inverter's DC input current.

**Note:** *Inverter's DC input current is calculated using rated AC output in watts, divided by lowest battery voltage, divided by inverter efficiency at that power level.*

- When the DC disconnect inside the MMP enclosure is not used as the DC overcurrent device, high interrupt, listed, DC-rated fuses or circuit breakers must be used in the battery cable circuits.

### Batteries

- Battery terminals and other live parts are guarded, and adequate working space around the battery bank is provided.
- Batteries are installed in well-vented areas (garages, outbuildings) and not in living areas.
- Adhere to the "IMPORTANT BATTERY SAFETY INSTRUCTIONS" at the beginning of this manual.

### Marking

- Battery bank is labeled with maximum operating voltage, equalization voltage, and polarity.
- Utility Back-up Systems: a visible exterior sign indicating the building contains an inverter back-up system and identifies the locations of the disconnects.
- An electrical system supplied by a 120 VAC only inverter must include a label warning against connecting multi-wire branch circuits.
- All required "WARNING" and "CAUTION" signs are installed in the proper locations, as required in the NEC/CEC.

### Inspection

- Electrical inspection complete and Certificate of Electrical Inspection issued by the local Authority Having Jurisdiction (AHJ). The local AHJ or inspector has the final say on what is or is not acceptable. Local codes may modify the requirements of the NEC/CEC.

*Part of this checklist is obtained from the Photovoltaic Electrical Power Systems Inspector/Installer Checklist created by John Wiles, Southwest Technology Development Institute, New Mexico State University, June, 2006.*



### 2.15 Functional Test

After all electrical connections from the MMP enclosure to the inverter, batteries, AC source, and sub-panel have been completed, follow these steps (refer also to Figure 2-26) to test the installation of the MMP enclosure and to verify proper operation of the BYPASS switch breakers.



**WARNING:** During this functional test, the front cover is removed and exposes personnel to potential dangerous voltages and shock hazards inside the MMP enclosure that may cause damage, injury, or death. If you do not have experience working with AC and DC voltage circuits, do not attempt this test—use an experienced electrical installer.



**CAUTION:** During this functional test, if any step cannot be verified or is incorrect, stop and recheck/correct the connections before proceeding to the next step.

1. Turn OFF all AC breakers (i.e., **INV BYP**, **INV IN**, and **INV OUT**) in the MMP enclosure.



**CAUTION:** Use a multimeter to verify the correct DC voltage for your particular inverter model (i.e., 24-volt battery bank for a 24-volt inverter) and to ensure the polarity of the battery voltage is correct [battery positive (+) connected to the inverter positive terminal thru the DC circuit breaker and battery negative (-) connected to inverter negative terminal thru the DC shunt].



**CAUTION:** Prior to turning on the inverter, turn OFF all inverter loads in the inverter load panel (i.e., sub-panel).

2. After verifying that the battery bank voltage is proper for your inverter and that the battery cable connections are the correct polarity, apply battery power to the inverter by turning the DC disconnect breaker to the ON (up) position.
3. Turn the inverter ON.
  - a. Connect an AC voltmeter to the **Inverter Output Terminals** and verify the correct AC output voltage of the inverter (depends on your inverter AC output voltage).



**Info:** If the inverter does not turn on—verify the DC connections to/from the inverter to the battery, and/or refer to the Troubleshooting section for your particular inverter.



**Info:** If the inverter has a Search mode feature, the inverter's AC full output voltage will not be present/correct until Search is turned OFF, or by connecting a large enough light bulb to bring the inverter out of Search. DO NOT connect anything but a light bulb until all wiring and voltages are confirmed to be correct.

If using a Magnum inverter, use a light bulb greater than 5 watts (5 watts is the default setting) to bring the inverter out of Search mode; or, the Search mode can be turned OFF with a remote control (ME-RC or ME-ARC).

4. Turn ON the **INV OUT**<sup>1</sup> breaker(s) in the MMP enclosure.
  - a. Ensure the inverter AC output voltage is passing thru the **INV OUT** (Inverter Output) breaker by verifying the correct output voltage is present on the **AC Output Terminals**.
5. Turn ON the **INV BYP**<sup>2</sup> breaker(s) in the MMP enclosure.
  - a. Ensure the inverter AC output voltage is no longer present on the **AC Output Terminals**.

**Note**<sup>1</sup> – On MMPxxx-60S models, the **INV OUT** and **INV IN** breakers are physically ganged together and turn ON and OFF as a single breaker.

**Note**<sup>2</sup> – The **INV BYP** and **INV OUT** breakers are interlocked together. Physically turning ON will turn OFF the other, and vice-versa.

6. Apply power from an external AC source (utility or AC generator) to the **AC Input Terminals**.
  - a. Connect an AC voltmeter to the **AC Input Terminals** and verify that the AC voltage from the external AC source is present. Connect the AC voltmeter to the **AC Output Terminals** and check that the external AC source power is passing thru the **INV BYP** (Inverter Bypass) breaker by verifying the AC source voltage present earlier is also present on the **AC Output Terminals**.
7. Turn ON the **INV OUT<sup>2</sup>** and **INV IN** breaker(s) in the MMP enclosure.
  - a. Ensure the AC source power is passing thru the **INV IN** (Inverter Input) breaker by verifying the AC source voltage present earlier (in Step 6) is also present on the **AC Output Terminals**.
8. After all the AC voltage checks pass, install the front cover and manually open and close all circuit breakers, checking for correct alignment and free operation.

If all the steps pass, the MMP enclosure is ready for use. If any of the steps fails, refer to the Installation section and recheck your wiring connections and/or refer to the Troubleshooting section for your inverter.

### MMP ENCLOSURE (AC SIDE)

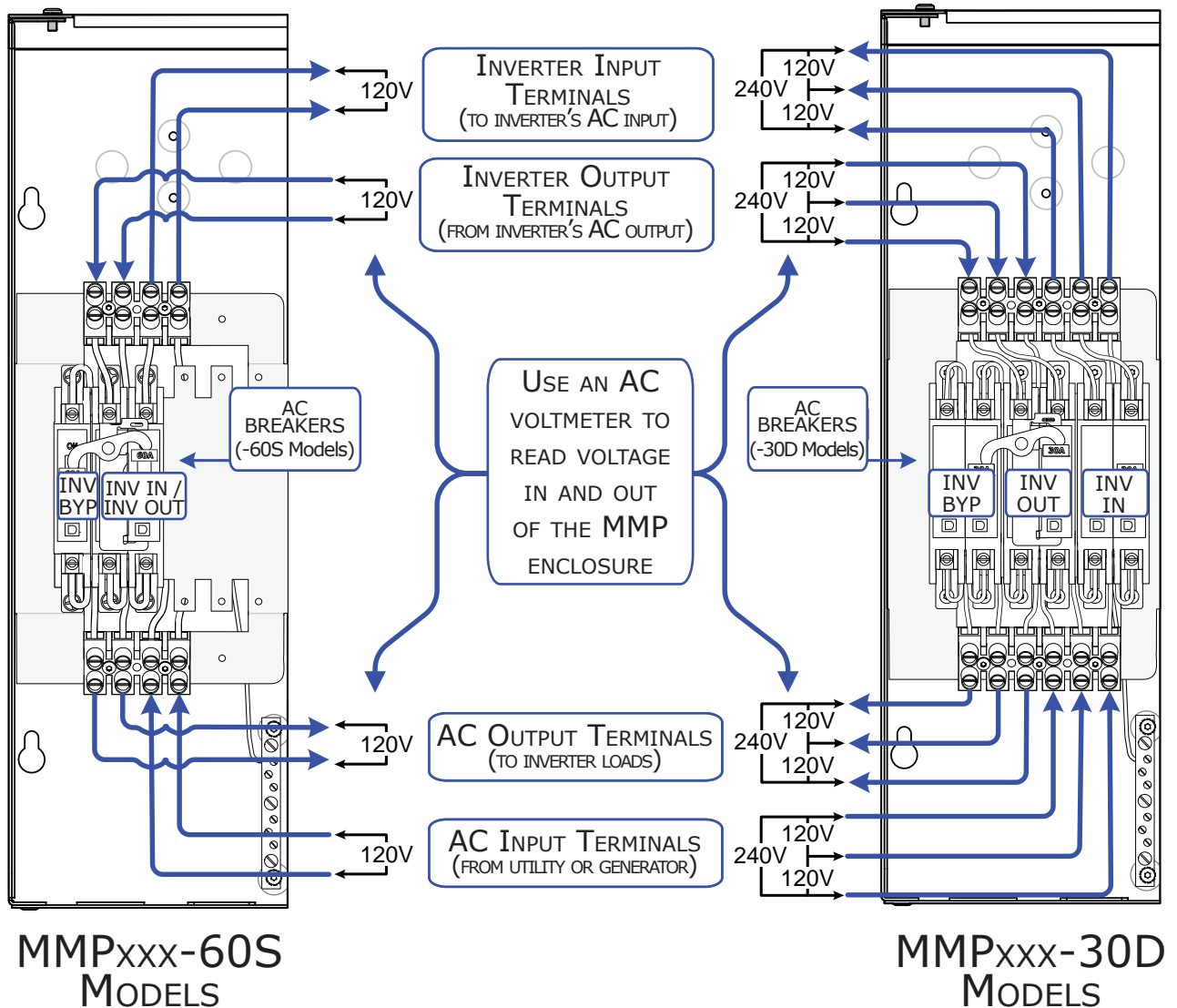


Figure 2-26, AC Voltage Checks

### 3.0 Operation

The MMP enclosure provides you with circuit breakers/disconnects to easily operate and maintain your inverter/battery system. These breakers are used as the main power disconnecting means and/or overcurrent protection. Refer to Figure 3-1 (MMP Functional Diagram) to see the functional operation of the breakers within the MMP enclosure.



**Info:** Figure 3-1 is for descriptive purposes only, for specific wiring directions please refer to the relevant wiring diagram in the Installation section of this manual.



**Info:** For information on operating the inverter, refer to its owner’s manual.

If a short-circuit condition occurs, or if a load is placed on the circuit breaker that is more than its rated capacity, the breaker will trip OFF (down). On the AC breakers, a red indicator will display through the clear window on the circuit breaker to show a tripped condition. On the other circuit breakers, the handle will trip all the way to the OFF position.

Before resetting the breaker, first determine the cause of the overcurrent fault. Then, reset the circuit breaker by turning it all the way OFF, and then all the way back ON. For proper maintenance and longer life, the circuit breakers should be turned off and on several times at least once a year. This will help to prevent the contacts inside from sticking together.

**To shut the MMP/inverter system OFF completely, all of the circuit breakers in the MMP enclosure should be switched to the OFF position.**

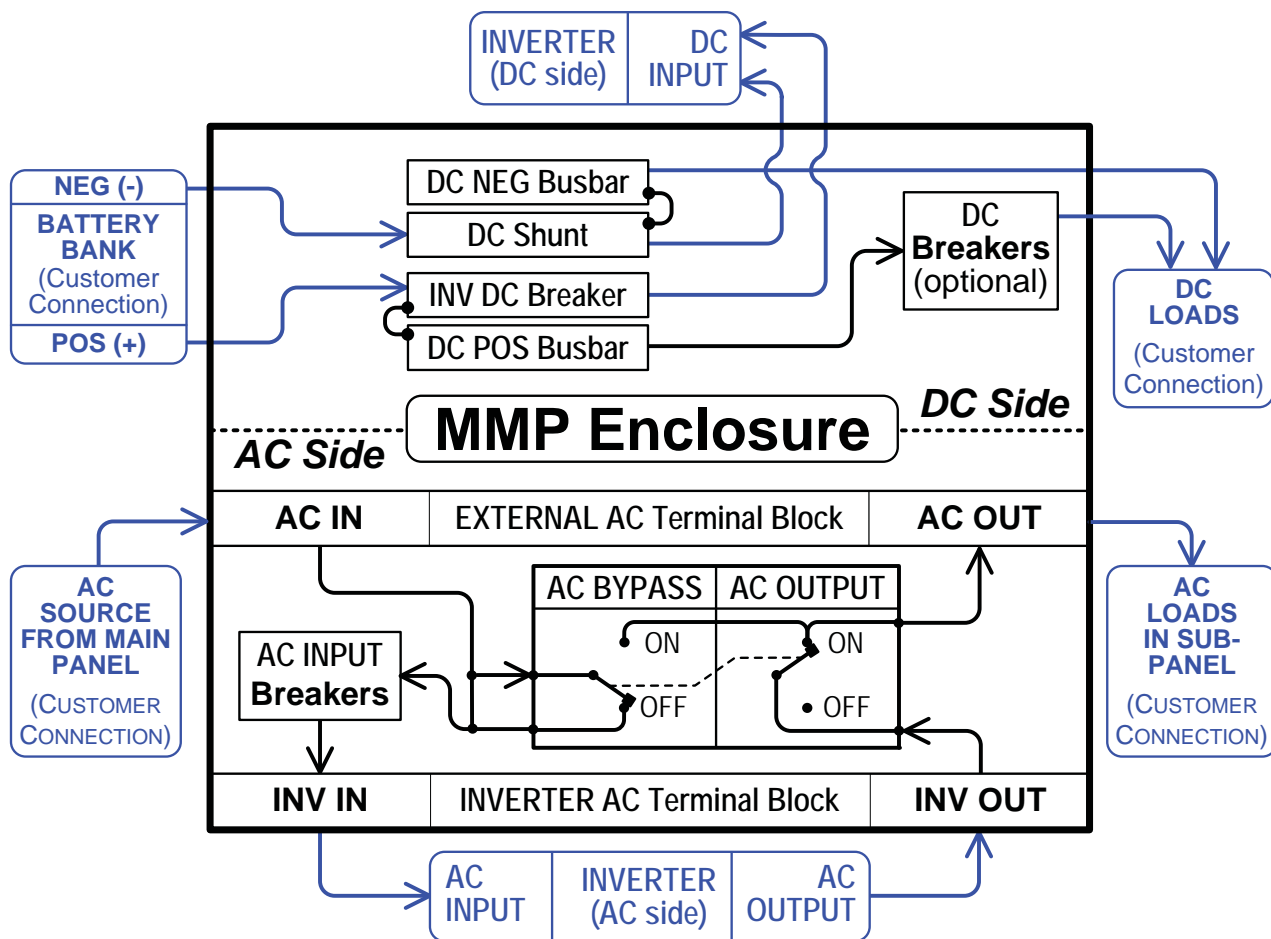


Figure 3-1, MMP Functional Diagram

### 3.1 Inverter DC Disconnect Breaker

The Inverter DC Disconnect Breaker is used to disconnect the battery during battery maintenance. This disconnect can also be used to protect the inverter, battery, and inverter DC cables from overloads and short circuits. The inverter DC disconnect does not, however, disconnect the battery power from the DC positive busbar in the MMP enclosure. So, if you have installed any optional DC load breakers, you must turn OFF all DC load breakers to disconnect battery power to all the DC loads.

**Before switching the DC Inverter Disconnect OFF, turn the inverter OFF.** This is to protect the inverter and other equipment from failure, and to preserve the contacts in the breaker.



**WARNING:** Do not use the DC disconnect breaker to turn your inverter on and off on a regular basis, it is there to provide safety and ease of maintenance. Turn off the inverter at its on/off switch first. However, in an emergency, the inverter DC disconnect is provided so that you can switch it off while the inverter is operating.



**Info:** Always switch the DC disconnect breaker to OFF before connecting or disconnecting the battery bank, to reduce the chance of spark and wear on the connectors.

### 3.2 AC Input Breaker

The AC Input Breaker when switched ON, allows the incoming AC source (utility or generator) to be connected to the inverter's AC input. This breaker should be switched OFF to disconnect the AC power from the inverter AC input.

On MMPxxx-30D models, this breaker is a dual-pole 30-amp circuit breaker (see Figure 1-3). On MMPxxx-60S models, the AC input disconnect breaker is one side of a dual 60-amp breaker; the other side of this dual 60-amp breaker is used as the AC output breaker (see Figure 1-5).

### 3.3 Inverter AC Output Breaker

The Inverter AC Output Breaker when switched ON, allows the AC power out of the inverter—either inverter power or pass-thru power (from the utility or generator)—to be connected to the AC loads. With this breaker OFF, the connected inverter loads beyond the MMP enclosure can be serviced.

On MMPxxx-30D models, this breaker is a dual-pole 30-amp circuit breaker (see Figure 1-3). On MMPxxx-60S models, the AC output disconnect breaker is one side of a dual 60-amp breaker; the other side of this dual 60-amp breaker is used as the AC input breaker (see Figure 1-5).

### 3.4 Inverter AC Bypass Switch Breaker

The Inverter AC Bypass Switch Breaker allows the inverter loads to continue to be powered by the incoming AC source (utility or generator) while isolating the inverter or battery system if maintenance or repair is needed.

This switch is pre-wired in the MMP enclosure between the incoming AC source and the inverter load panel (i.e., sub-panel). It connects the incoming AC source to the inverter's AC loads; either through the "inverter" or directly by "bypassing" the inverter. This bypass switch assembly uses a mechanical interlock between two AC breakers to prevent both breakers from being ON at the same time, but both can be OFF at the same time. This bypass switch is normally set to 'OFF' (inverter not bypassed), but can be easily moved to "ON" (bypass inverter) allowing the AC loads to continue to be powered if the inverter or battery bank needs to be serviced/disconnected—without any rewiring.

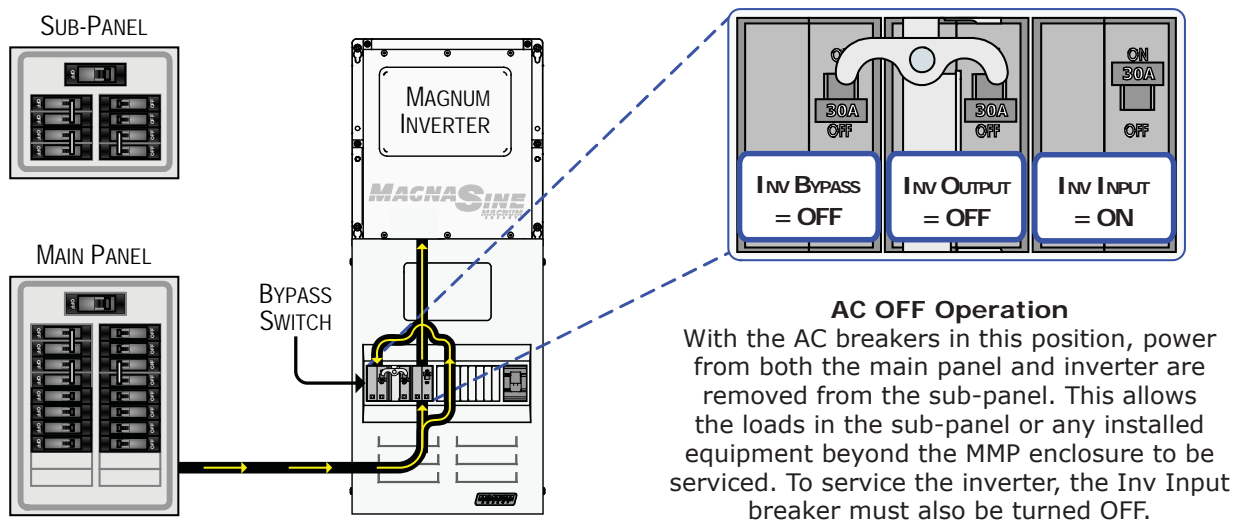
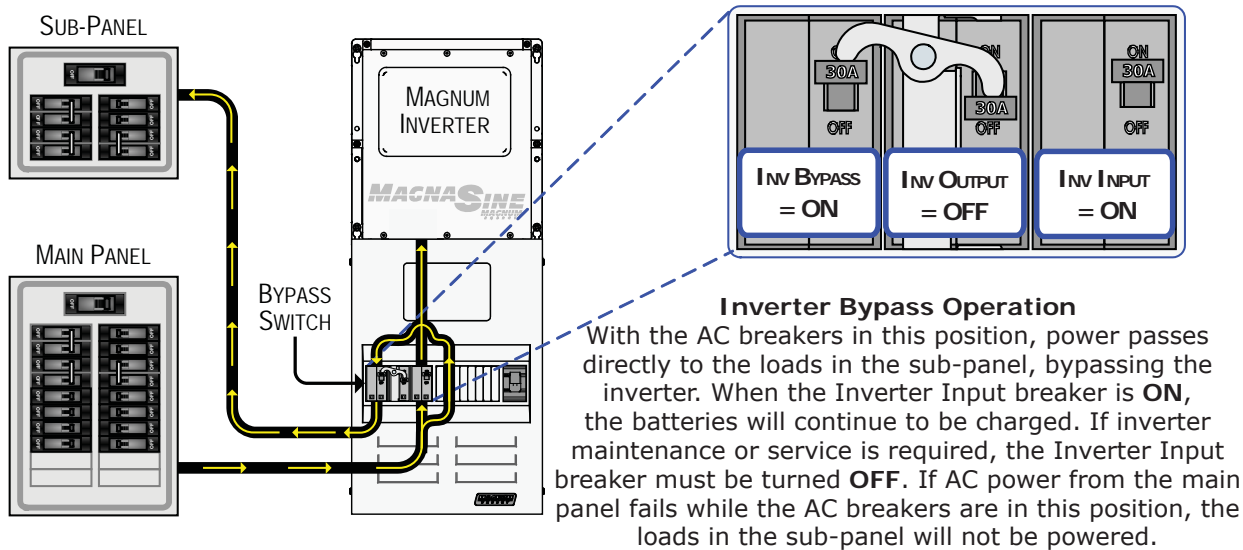
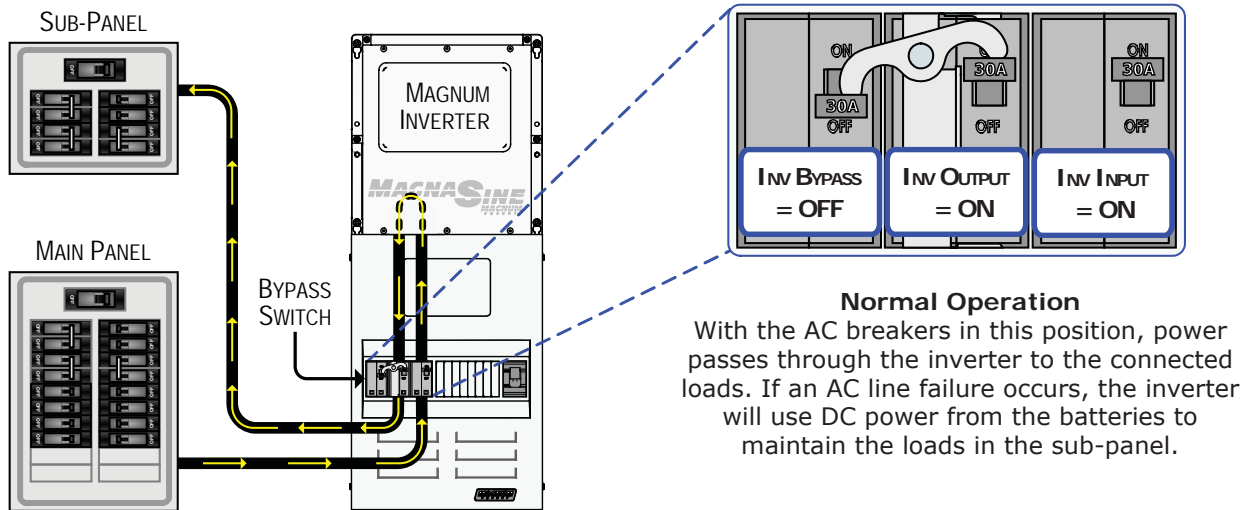
Refer to Figure 3-2 (MMPxxx-30D models) or Figure 3-3 (MMPxxx-60S models) to review the operational modes and power flow of the AC bypass switch.

**All AC loads should be turned off before switching the bypass switch breaker.**

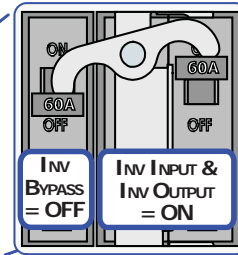
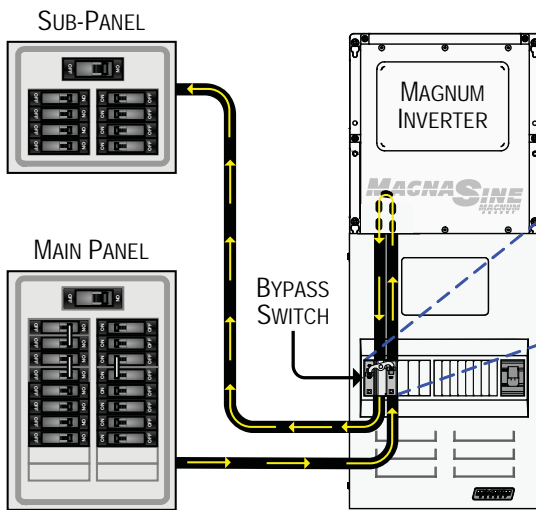


**Info:** When the bypass switch is ON the connected equipment is directly powered from the AC source (utility or generator), and will go off if the AC source is disconnected or turned off.

## Operation

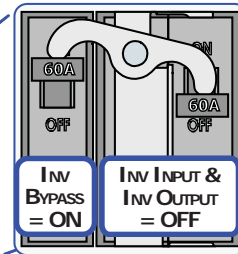
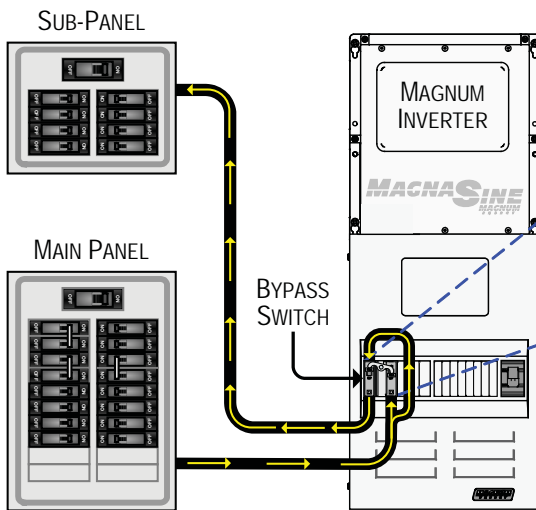


**Figure 3-2, MMPxxx-30D Bypass Switch Operation**



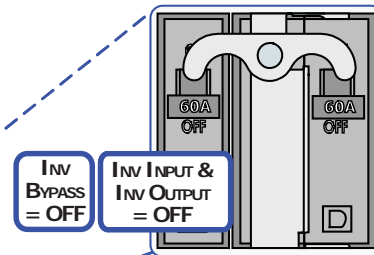
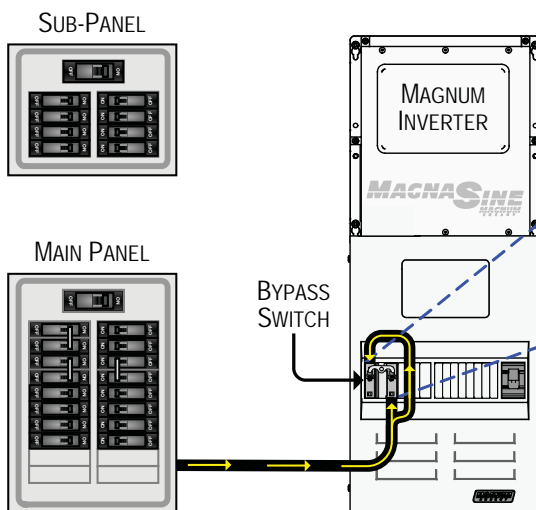
**Normal Operation**

With the AC breakers in this position, power passes through the inverter to the connected loads. If an AC line failure occurs, the inverter will use DC power from the batteries to maintain the loads in the sub-panel.



**Inverter Bypass Operation**

With the AC breakers in this position, power passes directly to the loads in the sub-panel, bypassing the inverter. In this configuration, the sub-panel loads will continue to be powered if inverter maintenance or service is required. If AC power from the main panel fails while the AC breakers are in this position, the sub-panel loads will not be powered.



**AC OFF Operation**

With the AC breakers in this position, power from both the main panel and inverter are removed from the sub-panel. This allows the inverter, the loads in the sub-panel, or any installed equipment beyond the MMP enclosure to be serviced.

**Figure 3-3, MMPxxx-60S Bypass Switch Operation**



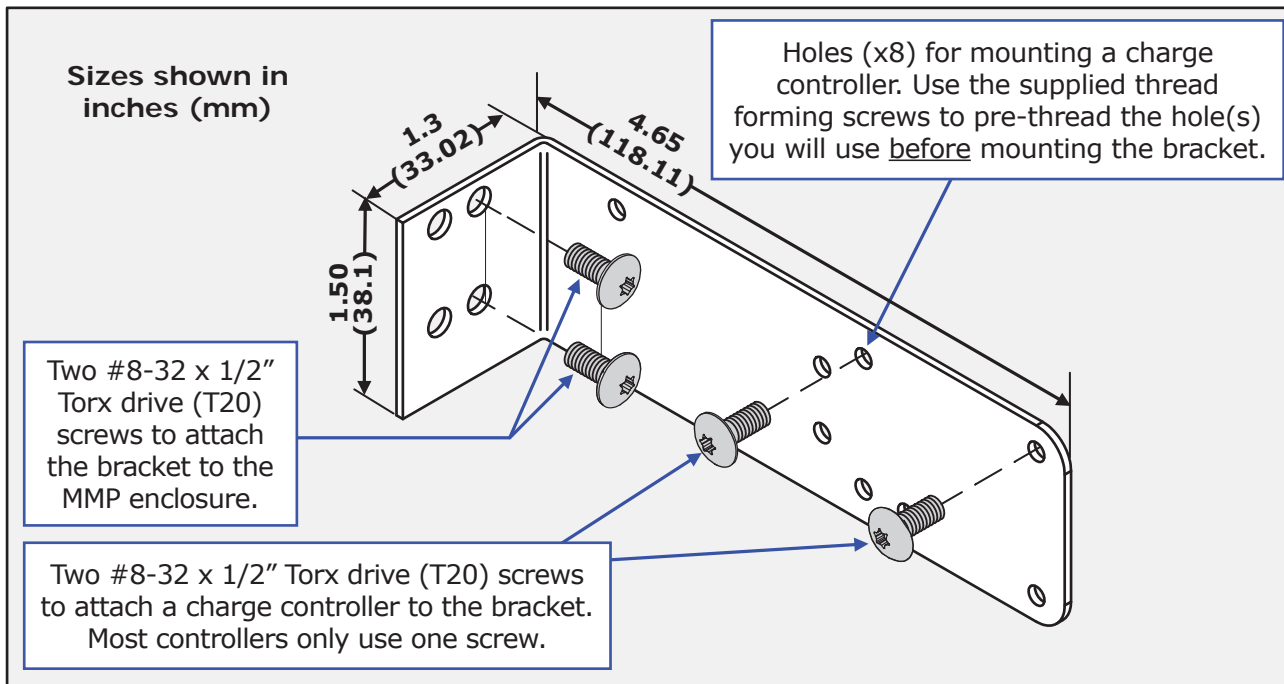
## Appendix A – Optional Equipment and Accessories

### A1 Installing the Charge Controller Bracket

A Charge Controller Bracket is provided to mount the most commonly used charge controllers to the MMP enclosure. This bracket can be easily mounted on either the left or right side of the MMP enclosure, and is designed to work with specific MidNite, MorningStar, or OutBack charge controllers.



**Info:** The necessary hardware is provided to secure the bracket to an enclosure and to mount a charge controller to the bracket (see Figure A1-1).



**Figure A1-1, Charge Controller Bracket – Physical Dimensions**

#### Installation

Before proceeding, use Table A-1 to determine the following for your particular charge controller:

- which side of the enclosure (left or right) to mount the controller,
- which enclosure mounting holes (upper or lower) are used to attach the bracket,
- which bracket hole(s) (A-G) are used to attach the controller.

**Table A-1, Mounting Holes Used for Charge Controllers**

Charge Controller	Holes to use: (Bracket) / [Enclosure]	
	Left Side Install	Right Side Install
Classic w/o Turbo (MN)	(B) / [upper]	(F) / [upper]
Classic w/Turbo (MN)	(A) / [upper]	(F) / [upper]
FlexMax 80 (OB)	NA	(G) and (E) / [upper]
Tristar (MS)	(D) / [lower]	(C) / [lower]

(MN) = MidNite, (OB) = OutBack, (MS) = MorningStar



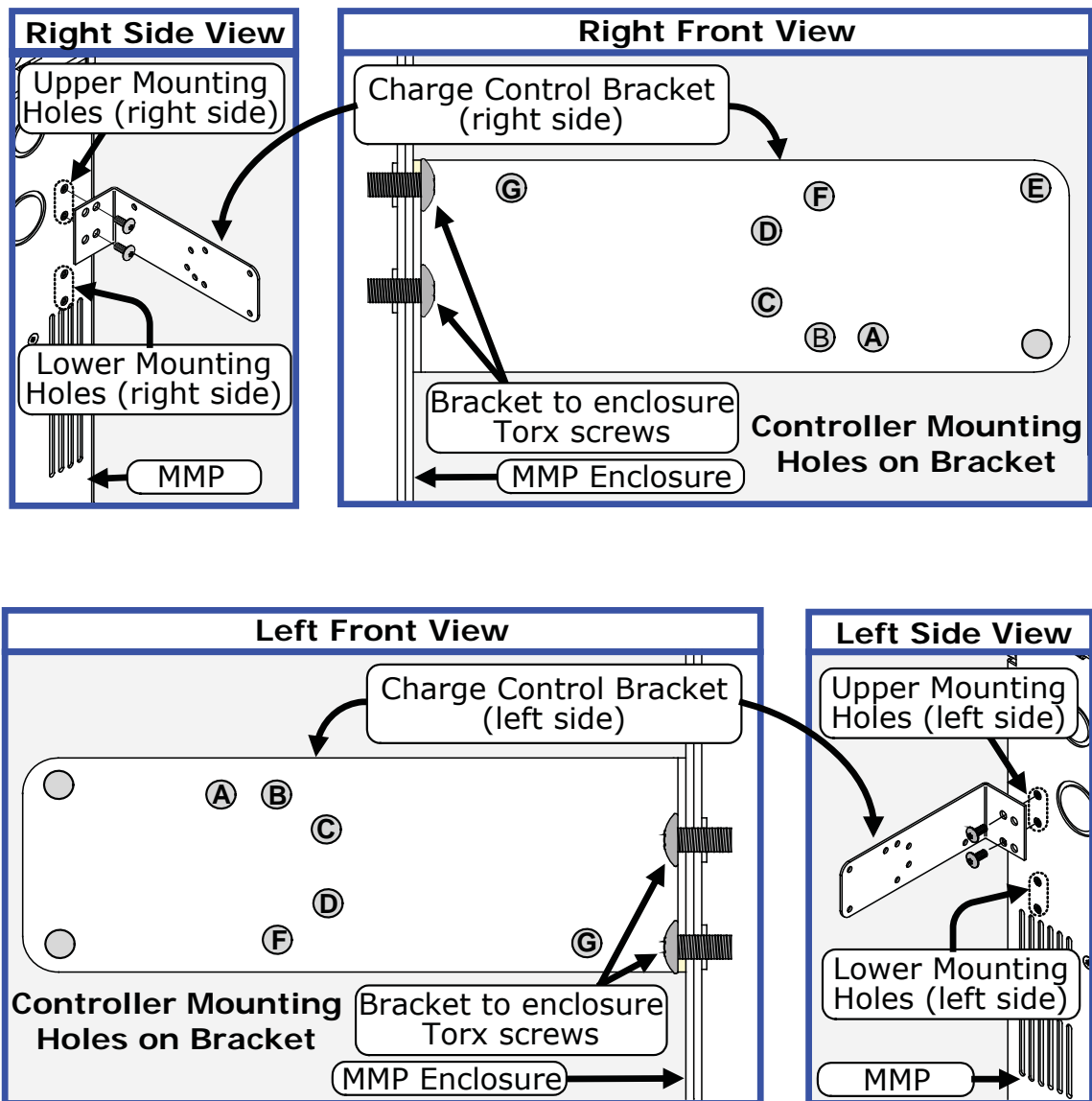
## Appendix A - Optional Equipment and Accessories

Refer to Figure A1-2 to locate the holes you will use to attach the charge controller to the bracket. Before mounting the bracket, use the provided T20 Torx drive, thread forming screws to pre-thread your selected mounting holes. It is easier to thread the holes now rather than doing it after the bracket and controller have been installed.

After pre-threading your particular bracket hole(s), locate the enclosure mounting holes you will use to attach the bracket to the enclosure. Before you mount the charge controller to the attached bracket, remove the appropriate knockout from the side of the controller and an adjacent knockout on the side of the enclosure. This allows you to use a one inch close nipple with two locknuts to secure the charge controller to the enclosure (in addition to the bracket), and provides a path to run the necessary wiring between the two units. Mount the controller to the attached bracket using the supplied hardware. Insert the close nipple through the knockouts and secure with the locknuts.



**Info:** It may take three locknuts on the close nipple to anchor the controller to the enclosure. An additional locknut may be required between the enclosure and the controller to act as a spacer. Also, a standard one inch plastic bushing should be used on the nipple ends to protect the wire insulation as it enters/exits the nipple.



*Figure A1-2, Holes Used to Mount Bracket on MMP Enclosure*

### A2 Installing a Remote Control

Complete the steps below to install the ME-RC or ME-ARC remote control on the MMP enclosure; refer to Figure A2-1 for assistance.

1. Unscrew the blank plate from the front cover, and remove the four 8-32 x 1/2 Phillips drive, black colored screws taped to the back of this blank plate.



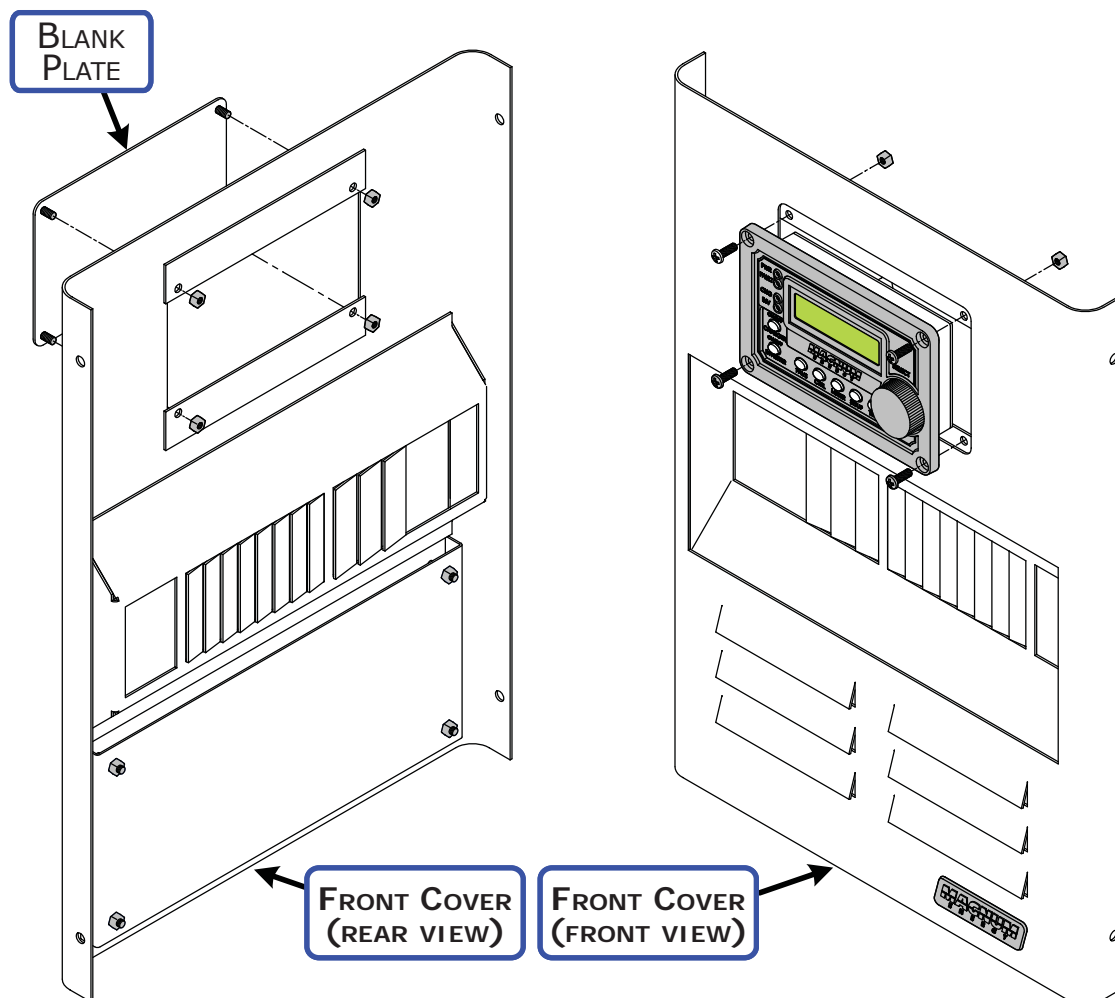
**Info:** The blank plate is attached to the front cover using #8-32 Hex nuts. Use a 11/32" socket or wrench to remove/reattach these nuts.

2. Use these four screws and the four nuts that were used to hold the blank plate to attach the remote control to the front cover.
3. Run the yellow colored remote cable that is provided between the remote and the Magnum inverter/charger.



**Info:** The remote cable is a 4-wire, twisted-pair, telephony standard with 300-volt rated insulation, and uses RJ14 (m) connectors on each end (see Figure 2-22). A standard telephone cable would not be code compliant and should not be used.

4. Connect one end of the remote cable into the RJ14 "REMOTE" port (has blue label) on the inverter/charger, and the other end into the RJ14 jack on the backside of the remote.



**Figure A2-1, Installing a Remote Control on the MMP Enclosure**

### A3 Installing a Battery Monitor

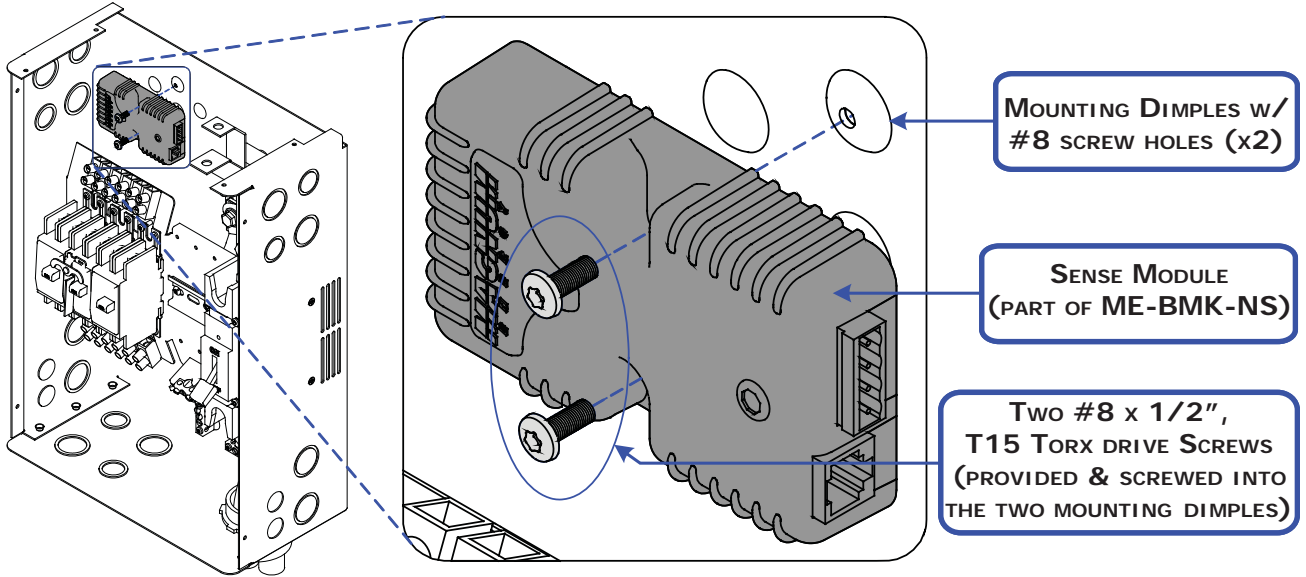


Figure A3-1, Mounting the Sense Module

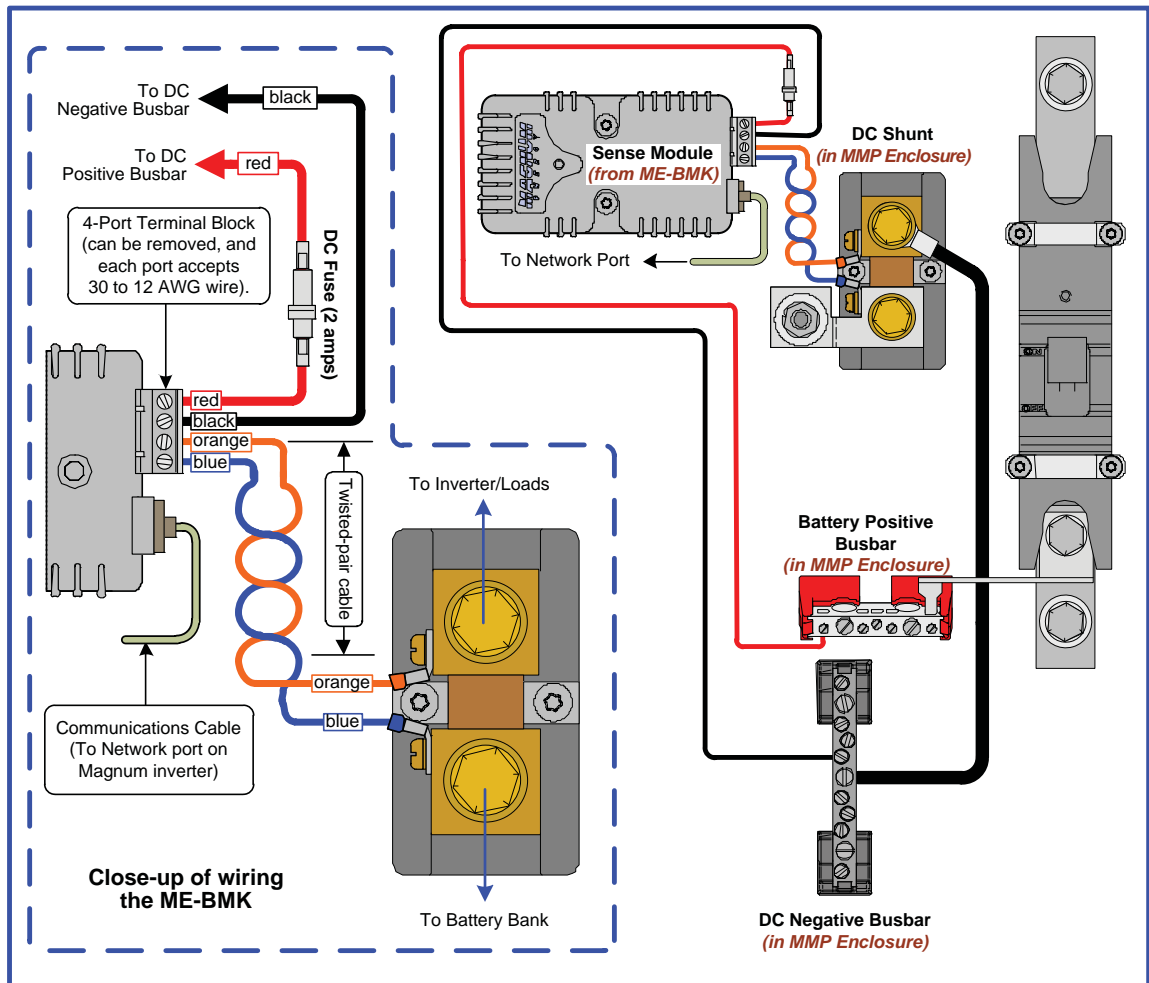


Figure A3-2, Wiring the Sense Module and DC Shunt

## Appendix A - Optional Equipment and Accessories

### A4 Knockout Plate

A knockout plate (PN: MMP-KP) can be purchased to facilitate running conduit from the top of the MMP enclosure, or for use as a safety plate. If your Magnum inverter is ever removed for service and the AC bypass breaker is used to continue to power the inverter loads, attaching the knockout plate prevents accidental access to live electrical circuits inside the MMP enclosure (see Figure A4-1).



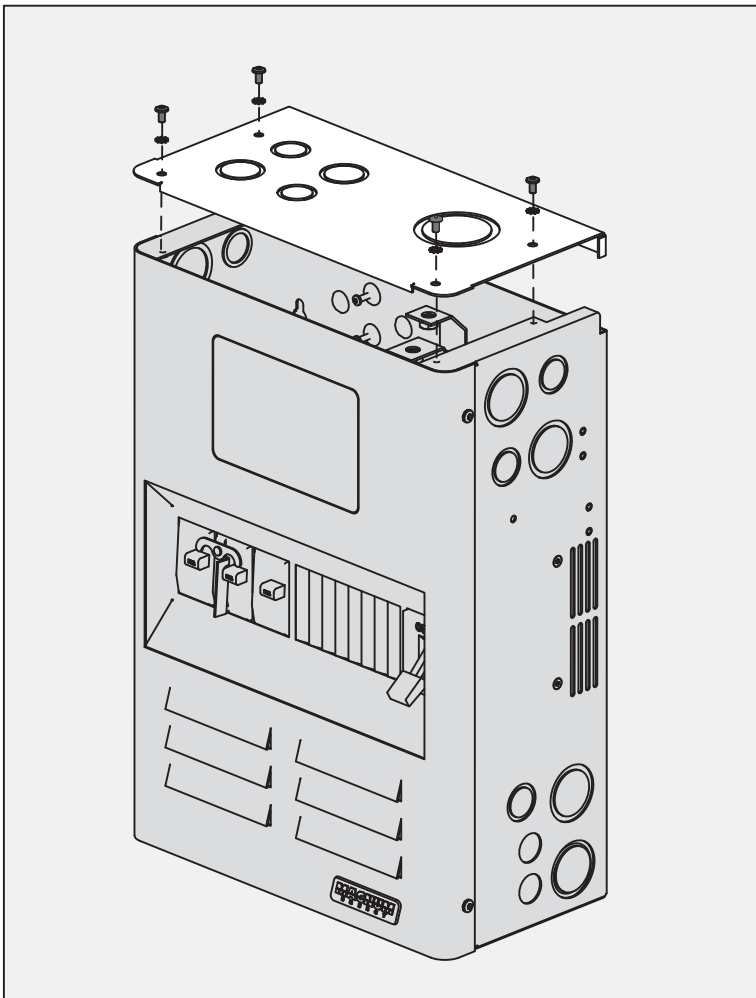
**WARNING:** If the knockout plate is used as a safety plate, the bus bars from the top of the DC disconnect **must be** prevented from touching the metal knockout plate or a short circuit to the battery bank may occur—causing very lethal currents. Either remove these bus bars or isolate them (i.e., using electrical tape/rubber caps), do not rely **ONLY** on turning the DC disconnect switch off.



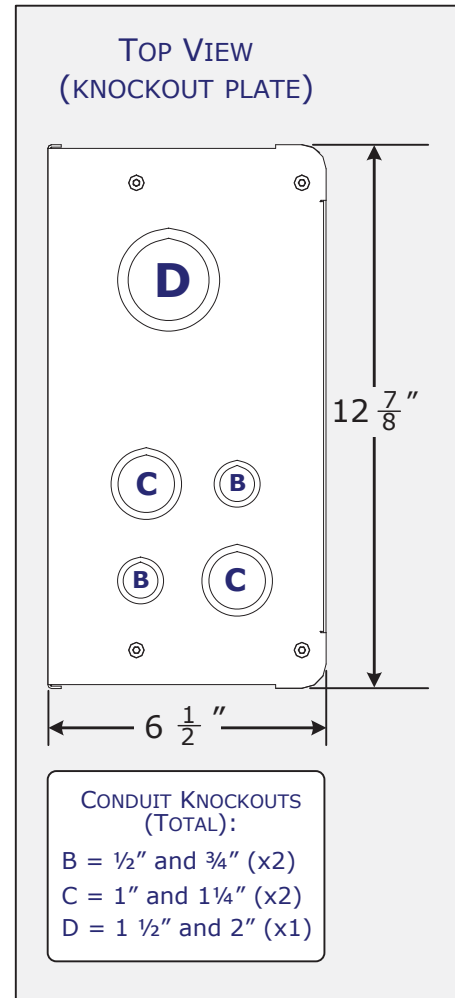
**Info:** Four #10-32 x 3/8" Pan head, T25 Torx drive, thread cutting screws; and four #10 lock washers are used to secure the knockout plate to the enclosure.



**Info:** Before removing the appropriate knockouts (Figure A4-2), think about whether you are going to use cable clamps or conduit, and all the different wiring required.



**Figure A4-1, Attaching Knockout Plate**



**Figure A4-2, Knockout Plate Dimensions and Knockouts**

## A5 Inverter Hood Info

The inverter hood (PN: MP-Hood) is a powder-coated steel cover plate, designed to prevent inverter damage from objects falling through the top vents of the inverter. The hood is required for installations when the inverters are mounted on a vertical surface (DC side down)—such as on the MMP enclosure.



**Info:** The hood does not mount to the inverter chassis, it must be mounted against the wall. The mounting slots on the hood will accept up to a maximum 1/4 inch screw/bolt.



**CAUTION:** The hood is not to be used as a drip shield to prevent water drip from entering the inverter.

### Installation Guidelines:

1. The bottom edge of the hood must be mounted flush against the top of the Magnum inverter; this is the optimal position for minimizing the risk of objects falling into the inverter, and at the same time providing the clearance needed for air flow from the top vents of the inverter.
2. Do not place anything on top of the hood that might cause it to bend downward; or, place anything on the sides to restrict air flow through the inverter.

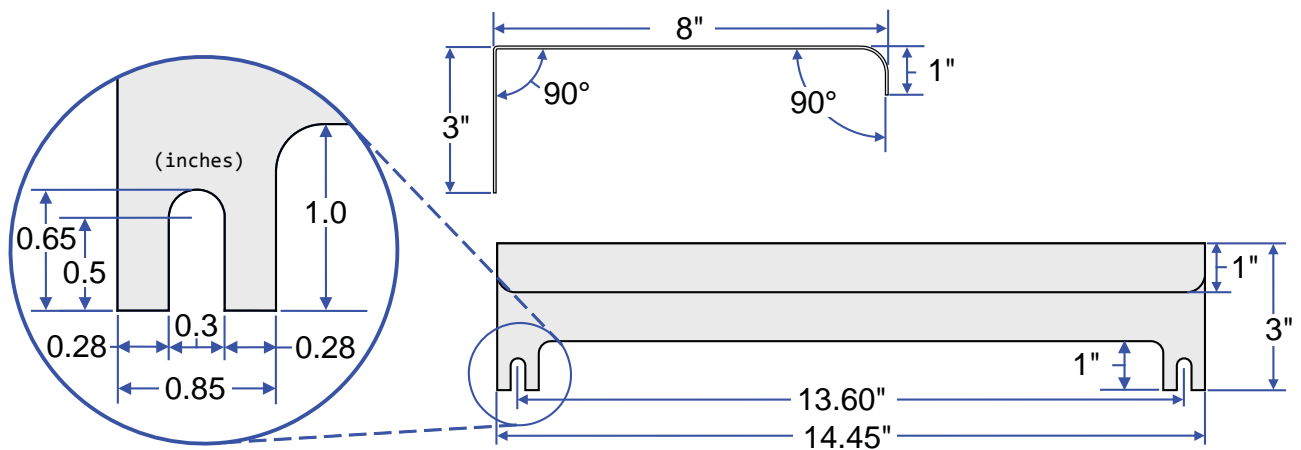


Figure A5-1, Inverter Hood Dimensions

### A6 Installing Optional DC Breakers

The MMP enclosure provides the room to install additional DC circuit breakers that may be used for charge controllers, a PV-GFP device, and other DC loads. This enclosure has been specifically designed to allow both back-mounted (1" wide)<sup>1</sup> or DIN rail-mounted (1/2" wide)<sup>2</sup> breakers.



**CAUTION:** Turning the DC disconnect breaker off only removes the battery power to the inverter, it does not interrupt power from the battery to the DC load breakers. This must be accomplished by turning off the DC load breakers themselves. Therefore, to shut the system off completely, all of the breakers in the MMP enclosure should be switched to the OFF position.

To install optional DC breakers inside the MMP enclosure:

1. Remove the front cover to the MMP enclosure.

2. **For DIN rail-mounted breakers**  
(refer to Figure A6-1):

- Install the breaker(s) on the DIN rail mounting track, and slide all the way to the left side.
- Place the breaker(s) on the DIN rail track, and slide a DIN rail clamp tight against the right side of last circuit breaker; and tighten this clamp to secure the breaker(s) on the DIN rail track.
- For each breaker installed, remove only one knockout (= 1/2" slot) in the front cover.

**For back-mounted type breakers**  
(refer to Figure A6-2):

- Remove the DIN rail mounting track by unscrewing the two #8, T15 Torx drive screws holding this mounting track.
- Secure the breaker(s) to the panel using two #8 screws, minimum 1/2" length.
- For each breaker installed, remove only two knockouts (= 1" slot) in the front cover.

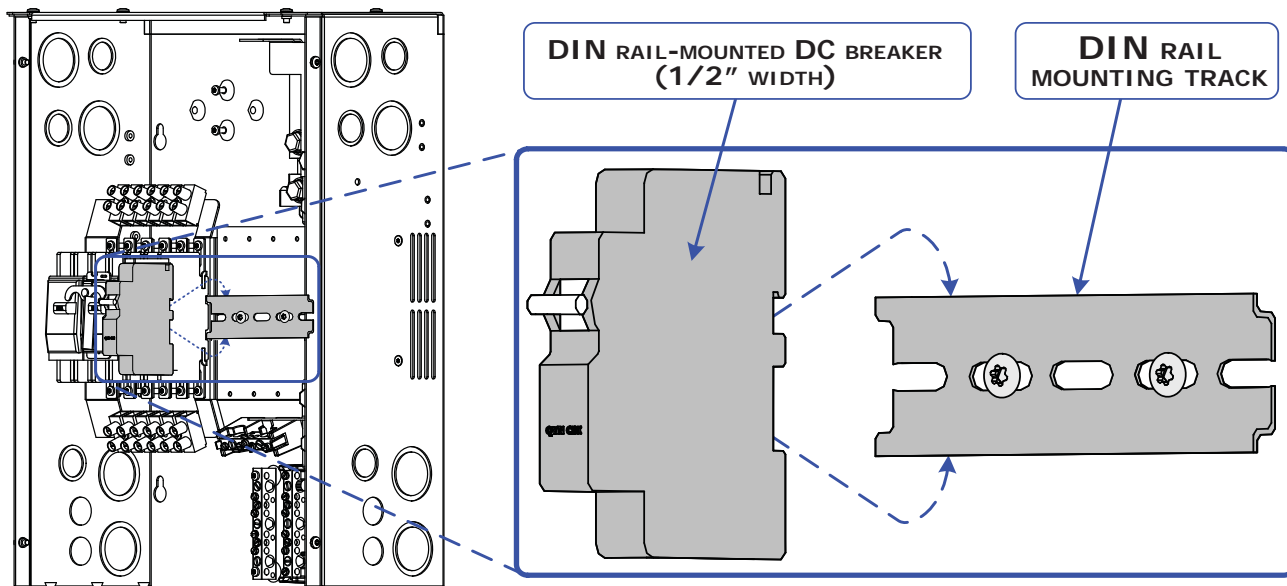
3. Ensure the breaker(s) align correctly into the spaces made by the knockouts removed from the front cover.

4. Wire the breaker(s) to the DC circuit, use Figure A6-3 to assist in wiring the breaker.

5. Replace the MMP front cover and check that the breaker operates correctly.

**Note<sup>1</sup>** – For the 1/2" wide DIN rail-mounted breakers, use Q-Frame types (QYN Series by CBI).

**Note<sup>2</sup>** – For the 1" back-mounted breakers, use E-Frame types (E Series by Carling Technologies, 209 Series by Airpax/Sensata Technologies or CF Series by Heinemann/Eaton).



**Figure A6-1, Installing DIN Rail-Mounted DC Breakers**



## Appendix A - Optional Equipment and Accessories

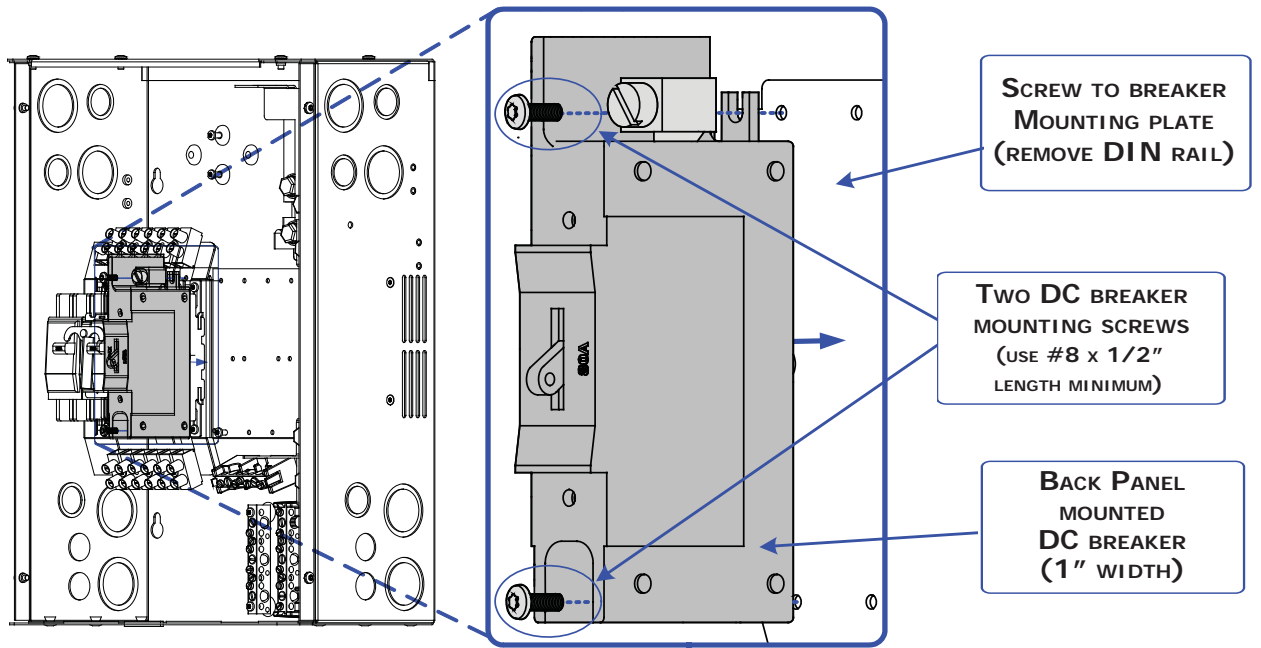


Figure A6-2, Installing Back Panel Mounted DC Breakers

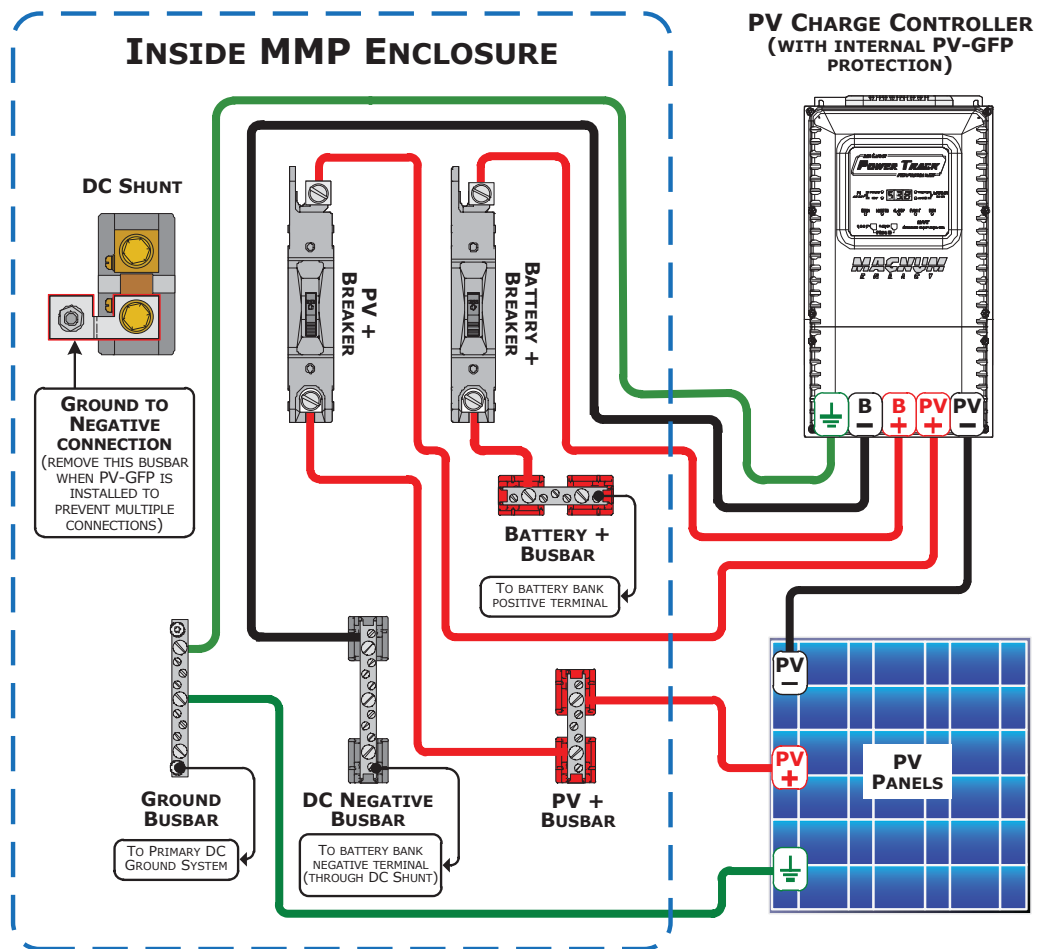


Figure A6-3, Wiring DC Breakers

### A7 Installing Lightning Arrestors

Unfortunately, in Renewable Energy (RE) systems where components are wired to outdoor electrical systems, there is a greater chance of damage to these components from lightning strikes. Lightning does not have to strike directly to cause damage, it can be far away and still induce power surges or spikes in the wires of the RE system. Since the RE wires are connected to the conductors coming into the house the inverters, charge controllers, batteries, and other components in the house or power shed are easily susceptible to damage.

The best line of defense against these high voltage surges—caused by lightning—is to ensure you have proper system grounding. Proper grounding attempts to divert lightning surges to earth, instead of going through your electrical components. However, for additional protection in lightning-prone areas or where good grounding is not feasible, install lightning arrestors (also known as high voltage surge arrestors) on the DC and AC circuits of your renewable energy system. Lightning arrestors are devices that respond to voltage variations instantaneously, effectively intercepting potentially damaging spikes and surges and reducing them to acceptable power levels to protect electrical equipment. Metal Oxide Varistors (MOVs), Silicone Oxide Varistors (SOVs), and Zinc Oxide Non-linear Resistors (ZNRs) are three types of lightning/surge arrestors.

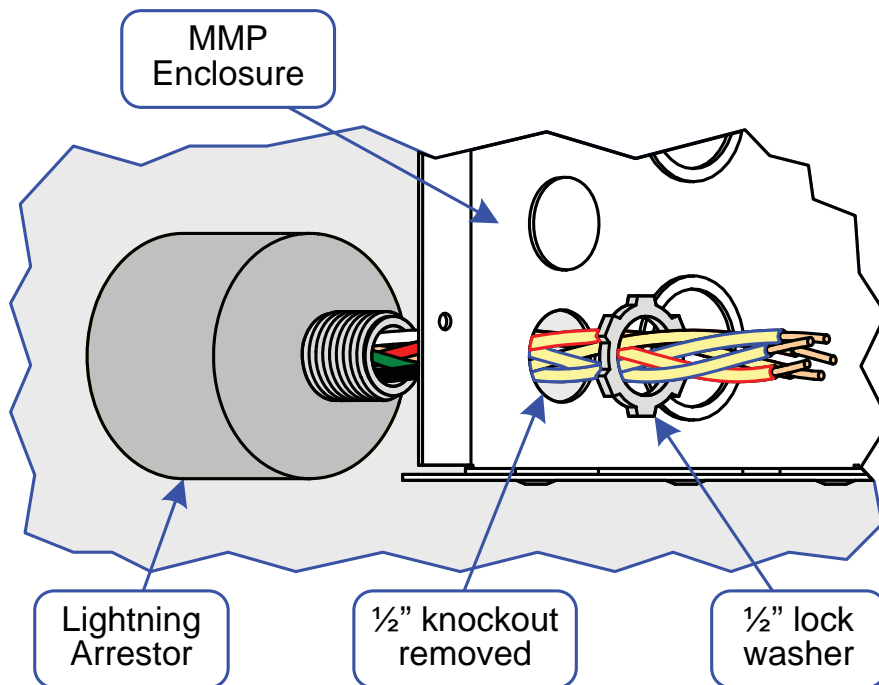
The most readily available lightning arrestors in the marketplace install into 1/2" conduit knockouts. Since the MMP enclosure is the central connection point for the main AC and DC electrical components of the renewable energy system, multiple 1/2" knockouts are provided to allow these lightning arrestors to be easily installed. The lightning arrestors should be connected as close to the equipment you are trying to protect as possible. Review Figure A7-1 for help installing these lightning arrestors, and use Figure A7-2 for assistance on wiring lightning arrestors on the DC and AC circuits inside the MMP enclosure.



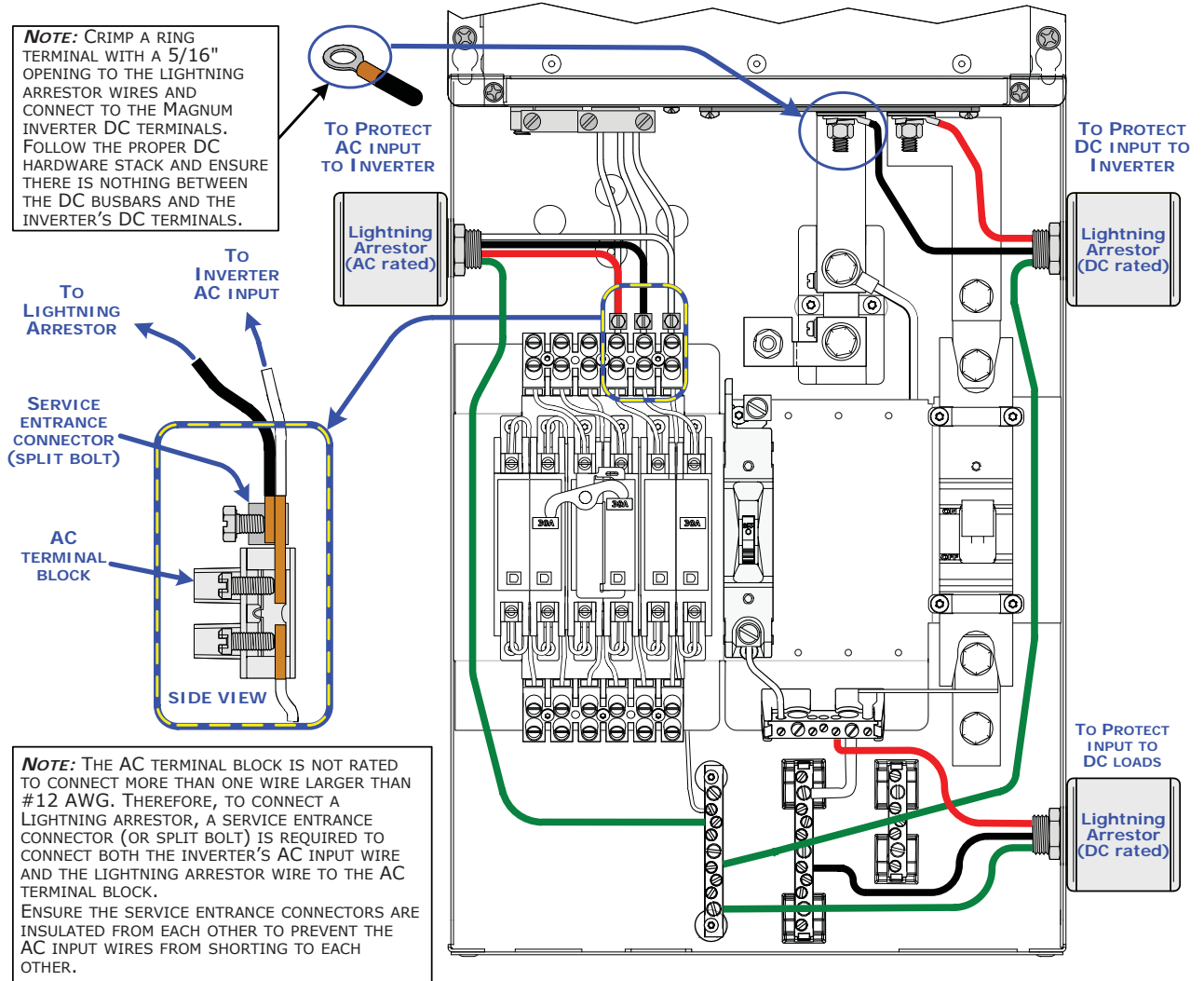
**Info:** Install additional lightning protection (secondary lightning arrestor) if equipment is more than 60 feet away from where the primary lightning arrestor is connected.



**Info:** For more information on lightning protection in RE systems, review *Protection Against the Effects of Lightning on Standalone Photovoltaic Systems – Common Practices* at [www.iea-pvps.org](http://www.iea-pvps.org).



**Figure A7-1, Installing Lightning Arrestor on MMP Enclosure**



**Figure A7-2, Wiring Lightning Arrester to MMP Enclosure**



**Info:** Make sure enough insulation is stripped so that the inverter's AC input wire is fully inserted in the AC terminal block and enough uninsulated wire is still available to contact with the lightning arrester wire when using the service entrance connector.



**Info:** Readily used service entrance connectors are available at most electrical dealers – for example, the Type SX manufactured by IlSCO ([www.ilSCO.com](http://www.ilSCO.com)), or the Type N manufactured by Thomas and Betts ([www.tnb.com](http://www.tnb.com)).

A8 MMP Back Panel Information

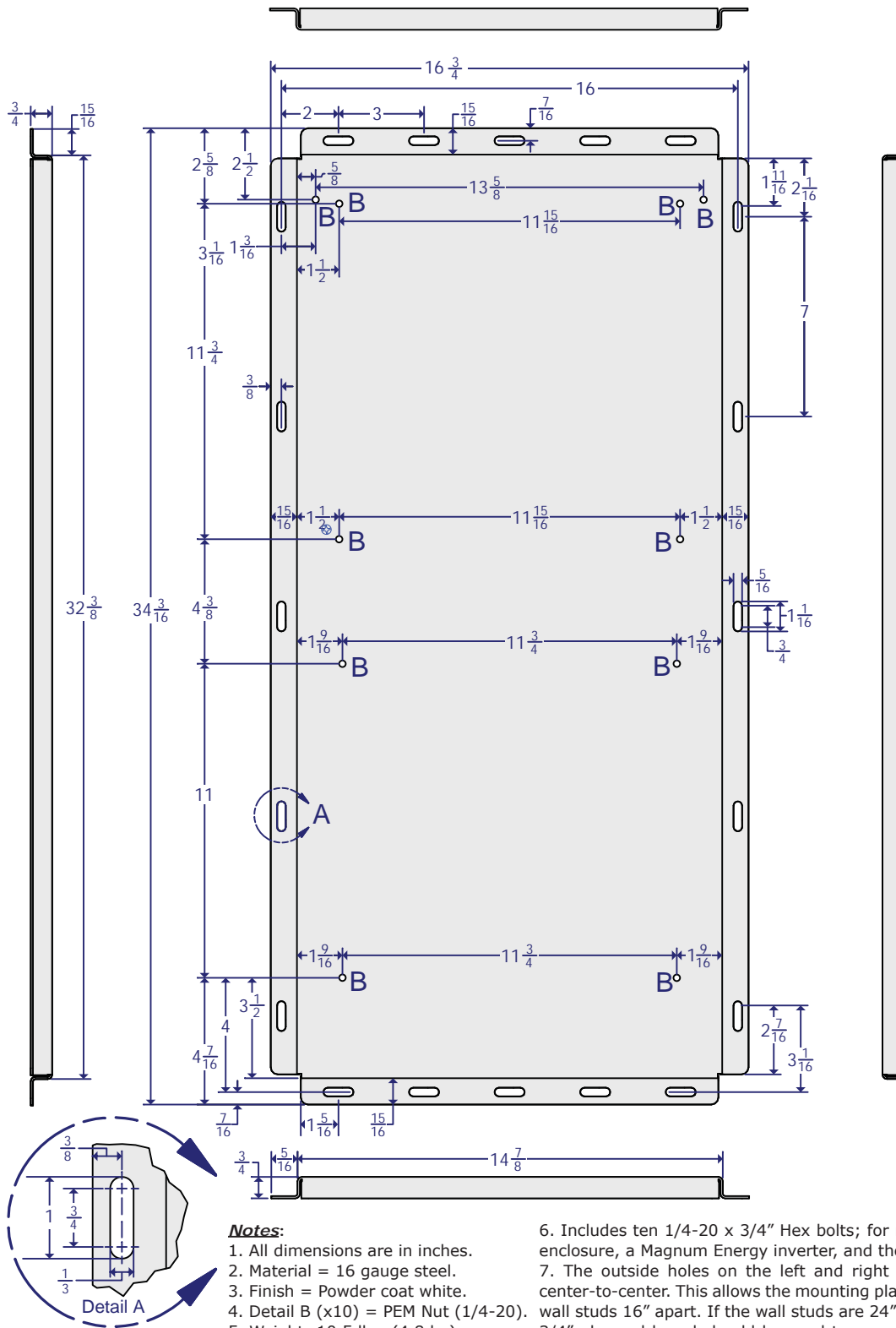


Figure A8-1, MMP Back Panel (BP-MMP) Information

### Appendix B – Using the MMP in a Mobile Application

The MMP Series is designed and approved for use in residential or commercial applications. It has been tested and listed to UL 1741, 2nd Edition (inverters, converters and controllers for use in Independent Power Systems) for use in the US; and is also certified to CSA C22.2 No. 107.1-01 (General Use Power Supplies) for use in Canada. The AC input and output neutral connections in the MMP are combined and are bonded to the internal ground bar. The bond from neutral to ground can be removed as neutral is bonded to ground from the primary AC source.

In a mobile application, the standards for safely wiring RV, truck, and marine installations in the United States requires the neutral and safety ground to be connected at the AC source; whether it is a shorepower feed, an inverter, or a generator. This maximizes the possibility that a circuit breaker will activate if a hotwire-to-ground fault occurs. These standards also require that the AC neutral be connected to safety ground (often called a "bond") in one, and only one, place at any time. The single bond is established in order to make the electrical panel's neutral line safe, by connecting it to ground. Without this bond, the neutral can have up to 60 VAC with respect to ground.

Because the neutrals are combined, if the MMP is used in a mobile application, more than one neutral to ground bond may be established, which can cause current to circulate between the multiple neutral to ground connections. This can cause "ground-loop" currents, which can trip GFCI's, cause an electrical shock hazard, and may be the reason for other annoying side effects.

### Appendix C – Warranty and Service

#### C1 Limited Warranty

Magnum Energy, Inc., warrants the MMP to be free from defects in material and workmanship that result in product failure during normal usage, according to the following terms and conditions:

1. The limited warranty for the product extends for 36 months beginning from the product's original date of purchase.

***Note:** You can extend the normal warranties on this MMP enclosure and a Magnum inverter or accessory to five years. To be eligible for this 5-year warranty extension, a proof-of-purchase is required at the time of repair/service showing that the Magnum inverter/accessory and the MMP panel system were purchased at the same time.*

2. The limited warranty extends to the original purchaser of the product and is not assignable or transferable to any subsequent purchaser.
3. During the limited warranty period, Magnum Energy will repair, or replace at Magnum Energy's option, any defective parts, or any parts that will not properly operate for their intended use with factory new or remanufactured replacement items if such repair or replacement is needed because of product malfunction or failure during normal usage. The limited warranty does not cover defects in appearance, cosmetic, decorative or structural parts or any non-operative parts. Magnum Energy's limit of liability under the limited warranty shall be the actual cash value of the product at the time the original purchaser returns the product for repair, determined by the price paid by the original purchaser. Magnum shall not be liable for any other losses or damages.
4. Upon request from Magnum Energy, the original purchaser must prove the product's original date of purchase by a dated bill of sale, itemized receipt.
5. The original purchaser shall return the product prepaid to Magnum Energy in Everett, WA. After the completion of service under this limited warranty, Magnum Energy will return the product prepaid to the original purchaser via a Magnum-selected non-expedited surface freight within the contiguous United States and Canada; this excludes Alaska and Hawaii.
6. If Magnum repairs or replaces a product, its warranty continues for the remaining portion of the original warranty period or 90 days from the date of the return shipment to the original purchaser, whichever is greater. All replaced products and parts removed from repaired products become the property of Magnum.
7. This limited warranty is voided if:
  - the product has been modified without authorization;
  - the product label and/or serial number label has been altered, defaced or removed;
  - the product has been damaged from abuse, neglect, accident, high voltage or corrosion;
  - the product was not installed and operated according to the owner's manual.

#### C2 How to Receive Repair Service

If your product requires warranty service or repair, contact either:

1. An Authorized Service Center, which are listed on the Magnum Energy website at [www.magnumenergy.com/Service/ServiceCenters-US.htm](http://www.magnumenergy.com/Service/ServiceCenters-US.htm), or
2. Magnum Energy, Inc. at: Telephone: 425-353-8833,  
Fax: 425-353-8390, or  
Email: [warranty@magnumenergy.com](mailto:warranty@magnumenergy.com)

If returning the product directly to Magnum Energy for repair, you must:

- Return the unit in the original, or equivalent, shipping container.

***Note:** Damage from shipping is not covered under warranty, ensure the unit is properly packaged.*

- Receive a Return Materials Authorization (RMA) number from the factory prior to the return of the product to Magnum Energy for repair.
- Place RMA numbers clearly on the shipping container or on the packing slip.

**BEFORE RETURNING ANY UNIT TO MAGNUM ENERGY INC.,  
A RETURN MATERIAL AUTHORIZATION (RMA) NUMBER IS REQUIRED.**





Magnum Energy, Inc.  
2211 West Casino Rd.  
Everett, WA 98204  
Phone: 425-353-8833  
Fax: 425-353-8390  
Web: [www.magnumenergy.com](http://www.magnumenergy.com)