

**FRONIUS IG 2000 / 3000 / 2500-LV**  
**FRONIUS IG 4000 / 5100 / 4500-LV**

**US** Operating instructions

Grid-connected inverters for  
photovoltaic systems





# Dear Reader

## Introduction

Thank you for choosing Fronius - and congratulations on your new, technically high-grade Fronius product! This instruction manual will help you get to know your new machine. Read the manual carefully and you will soon be familiar with all the many great features of your new Fronius product. This really is the best way to get the most out of all the advantages that your machine has to offer.

Please also take special note of the safety rules - and observe them! In this way, you will help to ensure more safety at your product location. And of course, if you treat your product carefully, this definitely helps to prolong its enduring quality and reliability - things which are both essential prerequisites for getting outstanding results.





# Safety rules

## DANGER!



“**DANGER!**” indicates an imminently hazardous situation which, if not avoided, will result in death or serious injury. This signal word must be limited to the most extreme situations. This signal word is not used for hazards relating to property damage unless there is also a risk of personal injury appropriate to this level.



## WARNING!



“**WARNING!**” indicates a potentially hazardous situation which, if not avoided, could result in death or serious injury. This signal word is not used for hazards relating to property damage unless there is also a risk of personal injury appropriate to this level.

## CAUTION!



“**CAUTION!**” indicates a potentially hazardous situation which, if not avoided, may result in minor or moderate injury. It may also be used to draw attention to unsafe practices that may cause damage to property.

## NOTE!



“**NOTE!**” indicates a situation which implies a risk of impaired results and damage to the equipment.

## Important!

“**Important!**” indicates practical hints and other particularly useful information. It is not a signal word for a harmful or dangerous situation.

Whenever you see any of the symbols shown above, pay close attention to the contents of the manual!

## General Remarks



This equipment has been manufactured in accordance with the state of the art and general safety-engineering principles. Nevertheless, incorrect operation or misuse may still endanger

- the life and well-being of the operator or of third parties,
- the equipment and other tangible assets belonging to the owner/operator,
- working efficiently with the equipment.

All persons involved in any way with starting up, servicing and maintaining the equipment must

- be suitably qualified
- have good knowledge of dealing with electrical installations and
- read this instruction manual thoroughly and follow the instructions to the letter.

The instruction manual must be kept at the machine location at all times. In addition to the instruction manual, it is important to comply with both the generally applicable and local accident prevention and environmental protection regulations.

## General Remarks

(continued)

All the safety instructions and warning signs on the machine itself:

- must be kept in a legible condition
- must not be damaged
- must not be removed
- must not be covered, pasted or painted over

For information about where the safety instructions and warning signs are located on the machine, please refer to the section of your machine's instruction manual headed "General Remarks".

Any malfunctions which might impair machine safety must be remedied immediately before the machine is switched on.

**Your safety is at stake!**

## Utilisation for Intended Purpose Only



The machine may only be used for jobs as defined by the "intended purpose".

Utilisation for any other purpose, or in any other manner, shall be deemed "not in accordance with the intended purpose". The manufacturer shall not be liable for any damage resulting from such improper use.

Utilisation in accordance with the "intended purpose" also comprises

- thorough reading of and compliance with all the instructions, safety instructions and warnings given in this manual
- performing all stipulated inspection and servicing work
- installation in accordance with the instruction manual

Where appropriate, the following guidelines should also be applied:

- regulations of the power supply company for input to the grid
- information provided by the manufacturer of the solar modules

## Ambient Conditions

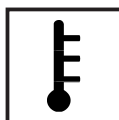

Operation or storage of the machine outside the stipulated range is deemed "not in accordance with the intended use". The manufacturer shall not be liable for any damage resulting therefrom.

Please refer to the technical data in your instruction manual for accurate information about the permissible ambient conditions.

## Qualified Staff



The servicing information provided in this instruction manual is only intended for qualified staff. An electric shock can be fatal. Please do not carry out any activities other than those referred to in the documentation. This also applies even if you are suitably qualified.



All cables and other leads must be firmly attached, undamaged, properly insulated and adequately dimensioned. Have loose connections, scorched, damaged or under-dimensioned cables and wires repaired immediately by an authorised specialist company.

**Qualified Staff**  
(continued)



Maintenance and repair may only be carried out by an authorised specialist company.

There is no guarantee in the case of parts sourced from other suppliers that these parts have been designed and manufactured to cope with the stresses and safety requirements that will be placed on them. Use only original spare parts (this also applies to standard parts).

Do not carry out any alterations, installations or modifications to the machine without first getting the manufacturer's permission.

Replace immediately any components that are not in perfect condition.

**Safety Precautions at the Machine Location**

Ensure when installing machines with cooling-air vents that the cooling air can flow freely through the air vents without obstruction. Only operate the machine with the degree of protection specified on the rating plate.

**EMC Precautions**



Care must be taken during installation to ensure that there is no occurrence of electromagnetic interference with electrical and electronic equipment.

**Electrical Installations**



Electrical installations may only be executed in accordance with the relevant national and regional standards and specifications.

**ESD Protective Measures**



Danger of damage to electronic components due to electrostatic discharge. Take appropriate protective measures when replacing and installing the components.

**Safety Precautions in Normal Operation**



Only operate the machine if all its protective features are fully functional. If any of the protective features are not fully functional, there is a danger to:

- the life and well-being of the operator or other persons
- the equipment and other tangible assets belonging to the owner/operator
- working efficiently with the equipment.

Have any safety features that are not fully functional repaired by an authorised specialist company before switching the machine on again.

Never bypass or disable safety features.



## Safety markings



Equipment with the CE mark fulfils the basic requirements of the Guideline Governing Low-Voltage and Electromagnetic Compatibility. (More detailed information about this may be found in the Annex or in the section of your documentation headed "Technical Data".)

## Disposal



Do not dispose of this device with normal domestic waste!  
To comply with the European Directive 2002/96/EC on Waste Electrical and Electronic Equipment and its implementation as national law, electrical equipment that has reached the end of its life must be collected separately and returned to an approved recycling facility Any device that you no longer require must be returned to our agent, or find out about the approved collection and recycling facilities in your area.  
Ignoring this European Directive may have potentially adverse affects on the environment and your health!

## Data security

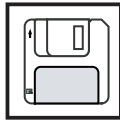

The user is responsible for backing up data relating to changes made to factory settings. The manufacturer will not accept liability if personal settings are deleted.

## Copyright



Copyright to this instruction manual remains the property of the manufacturer.

The text and illustrations are all technically correct at the time of going to print. The right to make modifications is reserved. The contents of the instruction manual shall not provide the basis for any claims whatever on the part of the purchaser. We should be most grateful for your comments if you have any suggestions for improvement, or can point out to us any mistakes which you may have found in the manual.



# Table of Contents

IMPORTANT SAFETY INSTRUCTIONS - SAVE THESE INSTRUCTIONS .....	4
General .....	4
Housing .....	4
Galvanic isolation .....	5
Monitoring the grid .....	5
Repair .....	5
Solar modules .....	5
Grid connection .....	6
Standards and Regulations .....	6
Product listings and compliance .....	6
How a photovoltaic system works .....	7
General information .....	7
Your roof is your power generator .....	7
Electricity is converted under the roof .....	7
<b>Operation manual .....</b>	<b>8</b>
The FRONIUS IG Unit in the PV System .....	8
General information .....	8
Converting DC into AC current .....	8
Fully automatic operation management .....	9
Voltage transformation and galvanic isolation .....	9
Monitoring the grid .....	9
Information for Field adjustable trip points .....	10
Display function and data communication .....	10
Your advantage .....	10
Product description .....	11
The FRONIUS IG Unit .....	11
How it functions .....	11
Startup phase .....	11
Overview for housing .....	13
LED for operating status .....	15
LED for GFDI status .....	16
Operating scheme .....	17
The Display .....	17
General information .....	17
Keys and symbols .....	17
Symbols .....	17

Display Navigation .....	18
Display illumination .....	18
Menu level .....	19
Select display mode .....	19
Scrolling between display functions .....	20
Display Modes .....	20
Display mode outline .....	20
Display symbol key .....	21
Display mode "Now" .....	22
Display mode "Day / Year / Total" .....	24
The Setup Menu .....	28
List of menu items .....	28
Display mode "Setup" .....	29
Enter the setup menu .....	29
Scroll among menu items .....	29
Setting the menu items .....	30
Additional information .....	39
Upgrading the system .....	39
Forced ventilation .....	40
<b>Installation manual</b> .....	<b>41</b>
Installation .....	42
Installation instructions .....	42
Safety .....	42
General information .....	42
Choosing the location general .....	43
Choosing the location .....	43
Preparing the wall mounting .....	44
Connection .....	45
Safety .....	45
General .....	45
Connection to the Solar Modules and to the Utility Grid .....	45
Solar modules .....	45
Grid connection .....	46
Schemes with more than one inverter .....	48
Connection .....	49
Connect DC .....	52
Connect AC .....	53
Start up Operation .....	53
Configuring your Inverter .....	53
Factory pre-set configuration .....	53
Your personal configuration .....	54

Ground fault indication .....	54
General .....	54
LocalNet .....	55
System upgrading / plug-in card system .....	55
Datalogger .....	55
COM Card .....	55
Insert plug-in cards .....	56
Configuration .....	57
Example .....	57
Status diagnosis and repair .....	58
Service-Codes Displayed .....	58
Service display .....	58
Normal operation service codes .....	58
System failure .....	59
FRONIUS IG with several power stage sets .....	59
Class 1 .....	60
Class 2 .....	61
Class 3 .....	62
Class 4 .....	63
Class 5 .....	65
Customer service .....	66
Annex .....	67
Technical Data .....	67
General .....	67
Field adjustable trip points .....	68
General .....	69
Field adjustable trip points .....	70
FRONIUS USA limited 10-Year Warranty .....	71
FRONIUS IG Solar Inverter Models:	
FRONIUS IG 2000 / 3000 / 2500 LV / 4000 / 5100 / 4500-LV .....	71
Policy and procedure for warranty returns and repairs .....	71
Disposal of obsolete equipment .....	72
Recycling .....	72

Declarations of conformity

Fronius Worldwide

# IMPORTANT SAFETY INSTRUCTIONS - SAVE THESE INSTRUCTIONS

## General



**WARNING!** Incorrect operation and work performed incorrectly can cause serious injury & damage! Only qualified staff are authorized to install your FRONIUS IG and only within the scope of the respective technical regulations. Do not start operation or carry out maintenance work before you have read the chapter "Safety Regulations"!

This manual contains important instructions for the FRONIUS IG 2000, 3000, 2500-LV, 4000, 5100, 4500-LV that shall be followed during installation and maintenance of the inverters.



**WARNING!** These servicing instructions are for use by qualified personnel only. To reduce the risk of electric shock, do not perform any servicing other than that specified in the operating instructions unless you are qualified to do so.

Electrical installations must be made in accordance with the National Electrical Code, ANSI/NFPA 70, and any other codes and regulations applicable to the installation site.

To reduce the risk of fire, do not connect multiwire branch circuits to an AC load center (circuit breaker panel).

## Housing

Only qualified installers are authorized to open the connection area.

Do not open the connection area when the inverter is under voltage.

Only Fronius-trained service staff may open the upper portion (power stage) of the inverter, and only when it is not under voltage.

**Galvanic isolation**

The design and function of the FRONIUS IG unit offers a maximum level of safety, both during installation as well as in operation. A complete galvanic isolation between the DC and AC sides is one such safety feature.

The FRONIUS IG provides galvanic isolation and grid monitoring. The passive and active measures for the protection of persons and equipment help ensure safe installation and operation.

**Monitoring the grid**

Whenever conditions in the electric grid are inconsistent with standard conditions (for example grid switch-off, interruption, etc.), your FRONIUS IG unit will immediately stop operating and interrupt the supply of power into the grid.

Your FRONIUS IG unit determines the grid's status by:

- monitoring voltage
- monitoring frequency
- monitoring islanding conditions

This scheme prevents dangerous voltages at the AC lines and constitutes an essential contribution towards avoiding hazards for the maintenance staff.

**Repair**

Only FRONIUS service staff are authorized to carry out repairs to the FRONIUS IG unit.

**Solar modules**

Before connecting the solar modules, you must check whether the voltage parameters specified in the manufacturer's data correspond with the actual parameters.

When checking the voltage reading, please take into account that solar modules supply a higher open circuit voltage when temperatures are low and sunlight level remains unchanged.

The data sheet of the solar module will tell you the temperature factors applicable for ascertaining the theoretical open-circuit voltage at 14 °F (-10 °C).

If the solar modules exceed an open-circuit voltage of 500 V, regardless of temperature the FRONIUS IG unit might be damaged and all warranty rights will be voided.

**Solar modules**  
(continued)

The FRONIUS IG includes a ground fault detector interruptor (GFDI) according to UL 1741. This device measures the ground current of the PV array and prevents the inverter from feeding the grid in case of a ground fault.

**Grid connections**

Only appropriately licensed contractors are authorized to connect your FRONIUS IG to the grid. Consult your local authorities for specific requirements.

Before connecting the FRONIUS IG to the grid, permission for the connection must be granted by the utility company.

**Standards and Regulations**

Your FRONIUS IG unit complies with the requirements for "Inverters, converters and controllers for use in independent power systems" UL1741-2005 and IEEE 1547 standards. The ground-fault detection and interruption is in compliance with NEC 690 building code requirements.

**Product listings and compliance**

The respective conformity declarations can be found in the appendix to these operating instructions.

# How a photovoltaic system works

## General information

The energy from worldwide sunlight amounts to a total of about 1,540,000,000,000,000,000 kWh/year (1,540 Peta kWh/year). This is 15,000 times as much as the electricity consumption worldwide. We congratulate you on your decision to actively use world's biggest energy resource. The word "photovoltaic" comes from the driving force behind this technology, which is light. When light strikes photovoltaic cells, a voltage and current is created.

## Your roof is your power generator

Power output and voltage are increased by combining a number of solar cells. If solar modules are connected in series like on a string, both the output power as well as the voltage will increase.

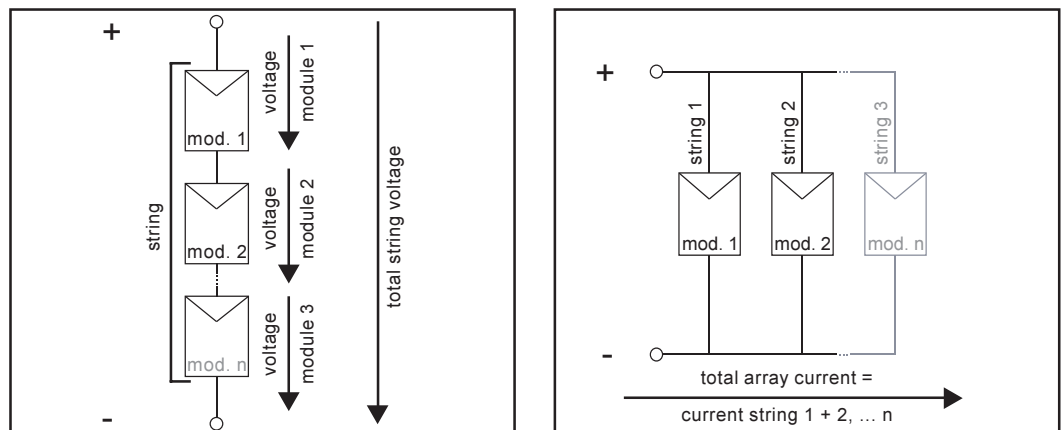

In a parallel connection of several such strings the output power and the output current will increase, while the voltage will remain unchanged (see right picture). The combination of all solar modules connected in series and parallel is called a solar array.

## Electricity is converted under the roof

The direct current generated in the solar modules can only be fed into the grid or used in your home after having been transformed by an inverter.

This is the basic purpose of your FRONIUS IG unit.

# Operation manual

## The FRONIUS IG Unit in the PV System

**General information** The FRONIUS IG is the latest generation of solar inverter. It is the highly complex link between solar modules and the grid.

As such it is responsible for a number of high-level tasks. The following diagram gives a graphical overview as to where the FRONIUS IG is placed in the PV system.

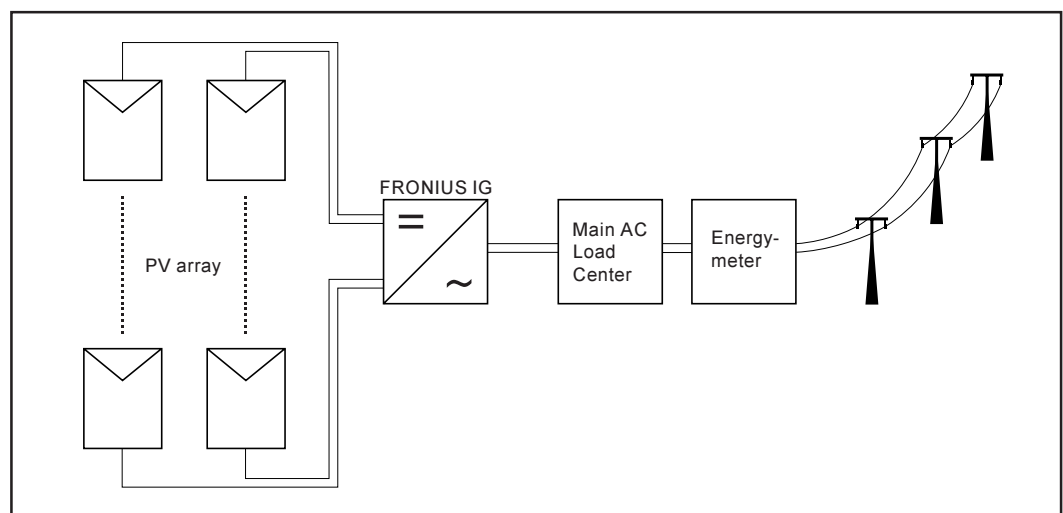

**Converting DC into AC current**

The FRONIUS IG unit transforms the direct current generated by the solar modules into alternating current. This alternating current is fed into your home system or into the public grid and synchronized with the voltage that is used there. The FRONIUS IG has been designed exclusively for use in grid connected photovoltaic systems. It cannot generate electric power independent from the grid.



**Fully automatic operation management**

The FRONIUS IG is fully automatic. Starting at sunrise, as soon as the solar modules generate enough power, the automatic control unit starts monitoring voltage and frequency. As soon as there is a sufficient level of insolation, your solar inverter starts feeding energy to the grid. A few Watts of solar power output are sufficient to achieve this.

The control system of the FRONIUS IG unit ensures that the maximum possible power output is drawn from the solar modules at all times.

This function is called MPPT (Maximum Power Point Tracking). It operates with extremely high precision. As dusk starts and there is no longer sufficient energy available to feed power into the grid, the FRONIUS IG unit shuts down the grid connection completely and stops operating. All settings and data recorded are saved.

**Voltage transformation and galvanic isolation**

The FRONIUS IG has been designed for use with solar modules of a wide range of input voltages. This allows the use of the greatest variety of types of solar modules. Important notice: the parameters indicated for maximum DC voltage (total voltage of the solar modules connected) must at no time be exceeded!

By its design and operation, the FRONIUS IG offers maximum safety during installation as well as in operation.

The FRONIUS IG is equipped with an HF-transformer (HF = high frequency) that ensures galvanic isolation between the DC side and the grid. In addition, the HF principle results in a drastic reduction of the transformer's size, which means that it requires less space and has considerably less weight. The FRONIUS IG unit achieves a high degree of efficiency due to its innovative circuit schemes.

**Monitoring the grid**

The FRONIUS IG unit monitors the grid. This responsibility comprises all measures necessary for the protection of persons and machines in case of a power blackout or other grid loss.

The FRONIUS IG unit is programmed to stop operation immediately and stop supplying power whenever conditions in the grid deviate from standard conditions (for example, when power is switched off or in case of any other kind of interruption).

**Monitoring the grid**  
(continued)

There are several ways the FRONIUS IG unit can identify a grid-cutoff, by monitoring:

- voltage
- frequency
- islanding conditions

**Information for Field adjustable trip points**

The FRONIUS IG unit is provided with field adjustable trip points. For further information please contact Fronius technical support E-Mail: [pv-us@fronius.com](mailto:pv-us@fronius.com).

**Display function and data communication**

The FRONIUS IG unit comes standard with a display that has been designed to enable quick and easy access to the most important data in your PV system.

The FRONIUS IG is equipped with a basic logging function to monitor minimum and maximum data on a daily and a cumulative basis. There is also an option to allow the reading of the following weather data on the display:

- two different temperature readings (for example, temperature at the solar modules as well as the outside temperature)
- irradiance

In addition to the functions installed in the FRONIUS IG unit, a wide choice of data communication products allows for many possibilities of recording and visualizing data. The respective components required to upgrade the system are easy to install.

**Your advantage**

With each additional parameter, that is controlled directly by the inverter, installation becomes easier and less costly because no additional peripheral equipment will be required. Based on our experience and the use of the most innovative technologies, the FRONIUS IG unit is able to manage all system parameters simultaneously.

In addition, the FRONIUS IG unit complies with a wide range of requirements established for the safety of people and other household appliances, as well for its own protection.

Some of these requirements are:

- ability to monitor the grid
- the quality of the electricity supplied
- immunity from outside disturbance and interference (for example, from mobile telephones).

# Product description

## The FRONIUS IG Unit

### How it functions

The FRONIUS IG unit is designed for fully automatic operation. No manual control is necessary for feeding the power it generates into the grid.

The FRONIUS IG unit starts operating automatically as soon as the power output of the solar modules is sufficient after sunrise.

During its operation the FRONIUS IG unit optimizes the voltage of the solar modules for maximum power output.

- the optimal voltage for any particular solar module is called MPP voltage (MPP = maximum power point)
- maintaining the exact MPP voltage guarantees an optimal level of efficiency for your modules at any time (MPP-tracking).

As soon as dusk begins there is no longer sufficient energy available to feed into the grid. The FRONIUS IG unit fully shuts off the grid connection at this time.

- during the night the FRONIUS IG unit draws less than 150 mW from the grid
- the data and parameters are saved
- it is also possible to shut the unit off manually

### Startup phase

After switching on automatically, the FRONIUS IG unit goes through a self-test, followed by an extensive test of the grid. This test takes five minutes. During the startup sequence the LED illumination is yellow.

#### (1) LCD test

- all display elements light up for about one second

**Startup phase**  
(continued)

**(2) TEST**

- self test of important components of the FRONIUS IG unit
- The FRONIUS IG unit goes through a master check list for several seconds
- the display says "TEST" and indicates the respective component which is being tested (for example "LED")

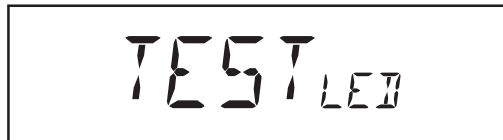

**(3) Synchronisation with grid**

- "WAIT<sub>PS</sub>" is displayed: The FRONIUS IG is waiting for all power supplies in the network to be on stand-by. This procedure takes place dependent on the DC-voltage.
- The screen displays "SYN-  
C<sub>AC</sub>"



- "SYNC<sub>AC</sub>" is displayed subsequently.



**(4) Startup test**

- Before the FRONIUS IG unit starts feeding energy into the grid, the conditions of the grid are tested in detail in accordance with regulations.
- the screen displays "START<sub>UP</sub>"

The startup test takes five minutes. The time elapsed is indicated by a bar shrinking from the top down.

Whenever two scale divisions stop flashing and disappear, 1/10 of the total duration of the test is over

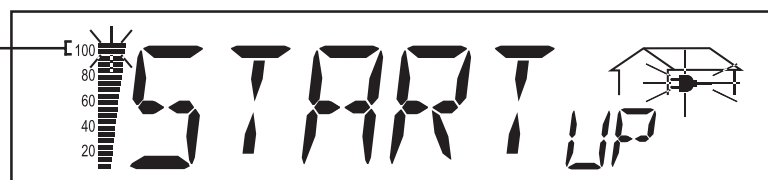

**(5) Operation of feeding energy into the grid**

- After conclusion of the tests, the FRONIUS IG unit starts feeding energy into the grid.
- The LED lights up green, and the FRONIUS IG unit starts operating

**Overview for housing**

- (1) Knockout for 1/2 in. / 3/4 in. conduit fitting (DC-cables)
- (2) Knockout for 1/2 in. / 3/4 in. conduit fitting (DC-cables)
- (3) Knockout for 1/2 in. / 3/4 in. conduit fitting (AC-cables)
- (4) Knockout for 1/2 in. / 3/4 in. conduit fitting (DC-cables)
- (5) Knockout for grounding electrode (may be required by local authorities)
- (6) Knockout for 1/2 in. / 3/4 in. conduit fitting (DatCom cables)
- (7) LCD
- (8) LED for operating status
- (9) LED for GFDI status
- (10) Knockout for 1/2 in. / 3/4 in. conduit fitting (DatCom cables)
- (11) Knockout for 1/2 in. / 3/4 in. conduit fitting (DatCom cables)
- (12) Air vents - Exhaust
- (13) Air vents - Intake

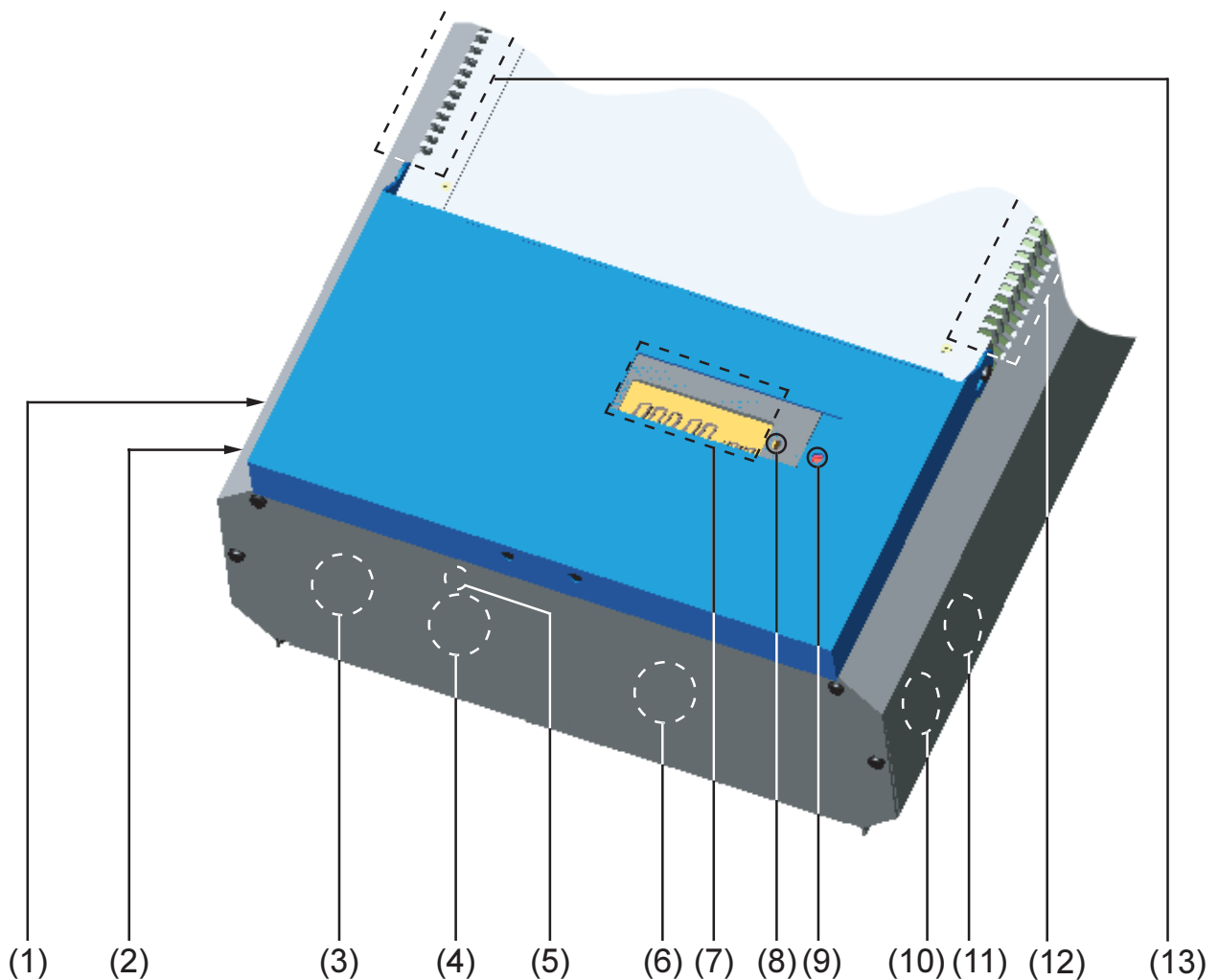

**Overview for housing**  
(Continued)

**⚠ WARNING!** Hazard due to supply voltage and DC-voltage from the solar modules. Only qualified electrical professionals are authorized to open the connection area of the FRONIUS IG and only when it is not under voltage.

- (14) Connection area - to be opened only by qualified electrical professionals
- (15) AC-disconnect
- (16) DC-disconnect
- (17) GFDI fuse
- (18) Menu buttons
- (19) Operating status LED
- (20) GFDI LED

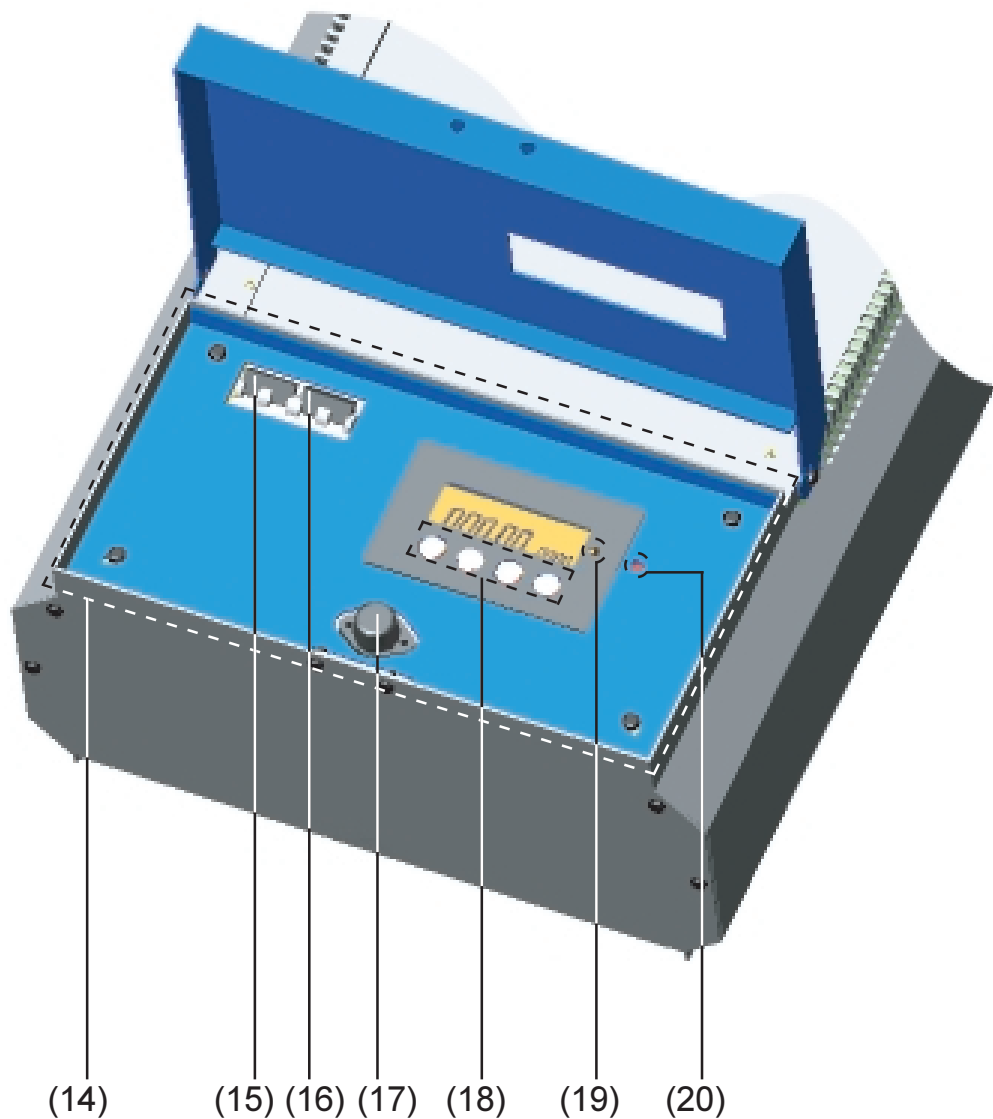

## LED for operating status

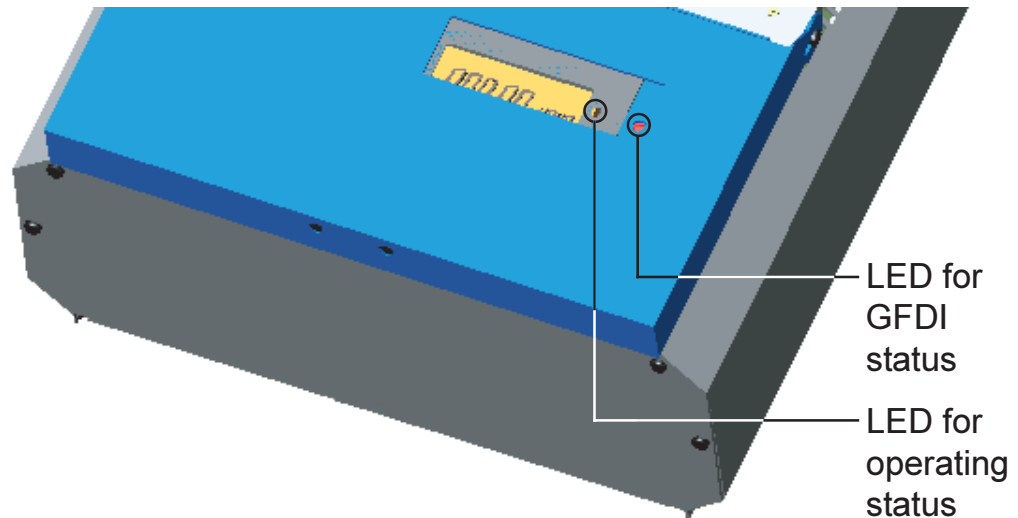

Depending on the operating status, the LED assumes different colors

### (1) LED lights up green:

- a green light starts as soon as the FRONIUS IG unit has completed the startup phase, and stays green as long as the operation of feeding power into the grid continues
- it indicates faultless operation of the photovoltaic equipment

### (2) LED flashes green:

- as long as the photovoltaic equipment is operating without fault
- an additional message is displayed on the screen

**👉 NOTE!** A service code may appear, for example, if there is a fault in the DatCom system. That does not affect the function of the FRONIUS IG. However, it is recommended that the fault is remedied as soon as possible.

The FRONIUS IG shows a status message.

If a service code (e.g., "504", in Section "Status diagnosis and repair") is shown, rectify the relevant condition and acknowledge the message by pressing the "Enter" button.

### (3) LED lights up orange:

- The FRONUS IG unit will enter the automatic startup-phase, as soon as the photovoltaic modules yield sufficient power output

**LED for operating status**  
(continued)

- (4) **LED flashes orange:**
- when a warning is displayed on the screen
  - or the FRONIUS IG unit has been set to standby operation in the setup menu (manual shutoff of operation)
  - the next day, operation will resume automatically
  - during the time the orange LED is flashing, the operation can be resumed manually at any time (see chapter "Setup Menu")

- (5) **LED lights up red:**
- general status: the respective service code is displayed on the screen

A list of all service codes, the corresponding status information, their status causes and repair measures can be found in the chapter "Status Diagnosis and Repair" of the installation and service manual.

- (6) **LED remains dark:**
- there is no connection to the solar modules
  - no power output from modules due to darkness

**LED for GFDI status**

- (1) **LED remains dark:**
- there is no ground fault in the PV system
  - the system is working properly
- (2) **LED lights up red:**
- ground fault is detected and fuse is blown
  - the inverter does not feed energy to the grid
  - the ground fault needs to be removed and the fuse needs to be changed (see chapter "Ground fault indication" in the installation manual)



# Operating scheme

## The Display

**General information** The FRONIUS IG unit is pre-configured to be ready for operation. Therefore it is not necessary to make any adjustments for it to operate and feed power into the grid.

### Keys and symbols

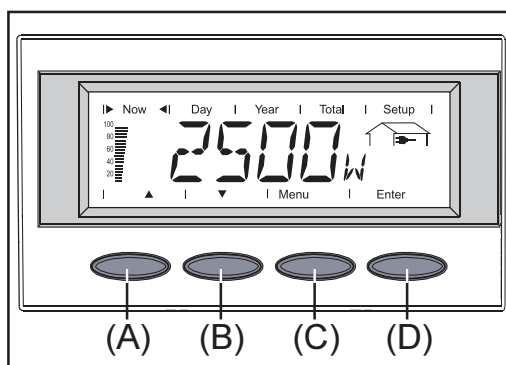

(A) and (B) keys:  
- scrolling

(C) key:  
- switching to the menu level ("Menu") or exit from the setup menu ("Esc")



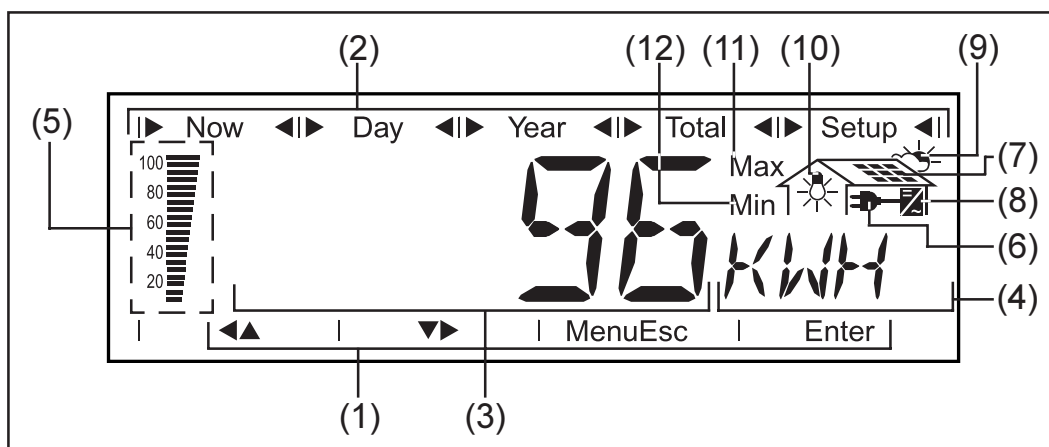

"Enter" Key (D):  
- confirming a choice

### Symbols



- (1) symbols for keys (A) through (D)
- (2) symbols for the display modes "Now" through "Setup"
- (3) area for data display ... for displaying the data value measured
- (4) area for unit display ... for displaying the applicable measuring unit

## Symbols (continued)

- (5) **output bar** ... indicates the power output fed into the grid at a given moment - independent from the display mode chosen. The screen displays % of the maximum possible output power of your solar inverter
- (6)  ... appears with AC data readings that are directly related to the grid
- (7)  ... appears with data readings that are directly related to the solar modules
- (8)  ... appears with data readings that are related directly to the FRONIUS IG unit
- (9)  ... appears with data readings that are related to environmental conditions, like sunlight insolation and temperature (optional)
- (10)  ... appears with data readings that are transmitted by the consumption sensor (optional)
- (11) **Max** ... indicates the maximum value within the period of observation (depending on the display mode chosen)
- (12) **Min** ... indicates the minimum value within the period of observation (depending on the mode of display chosen)

**Important!** The Min. and Max. values may not correspond to the absolute extreme values, as the measured data is recorded at two second intervals.

## Display Navigation

### Display illumination

Press any key to activate the display backlight. If no key is pressed for 30 seconds, the display backlight stops. The setup menu also offers a choice between permanently alit or permanently dark display.

## Menu level

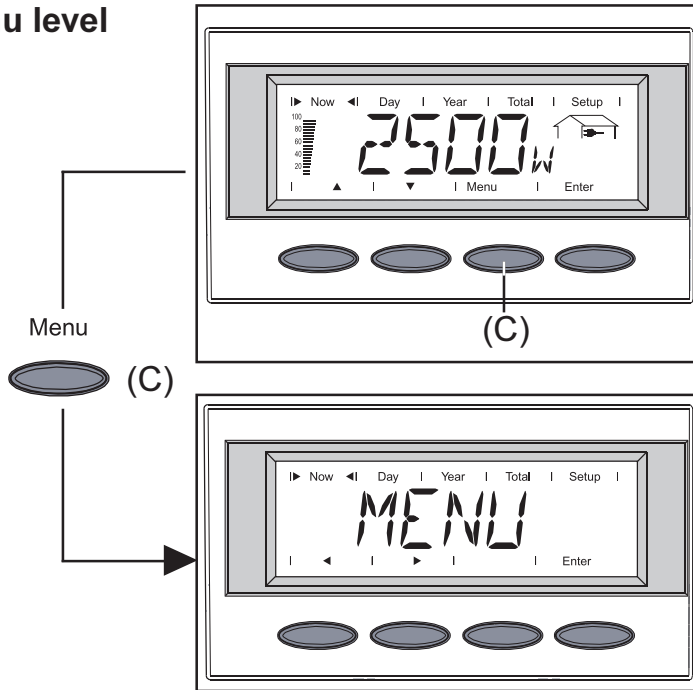

From the menu level you can enter the display mode or the setup menu.

Access the top level menu by pressing the (C) key.

- the screen displays "Menu"
- the display is operating in the top level menu

## Select display mode

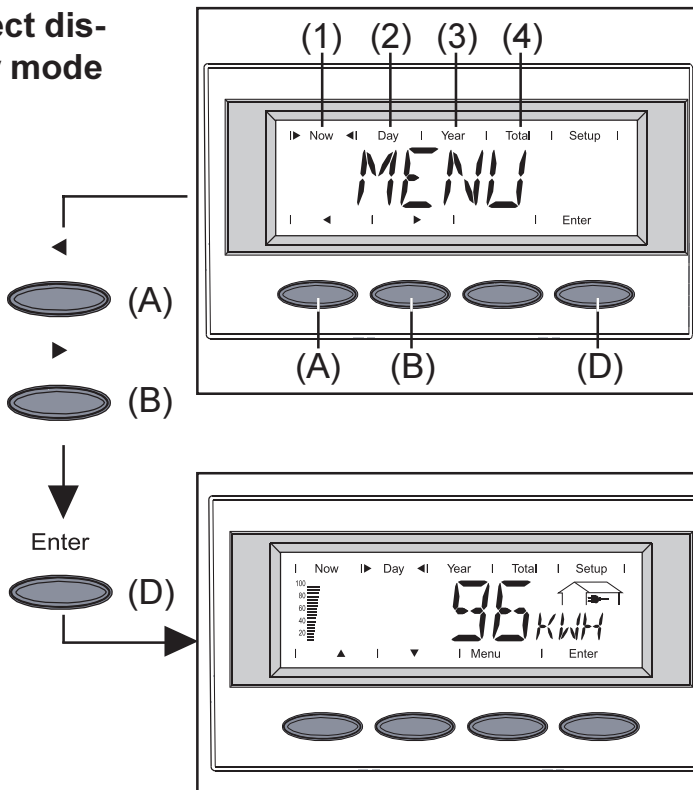

Select from the available modes: Instantaneous data, daily data, annual data, or total data over the life of the FRONIUS IG.

- select the desired display mode (1) to (4) by pressing keys (A) or (B)
- enter the display mode selected by pressing the key "Enter" (D)

**NOTE!** The menu item "Year" is only supported when the Datalogger is connected.

## Scrolling between display functions

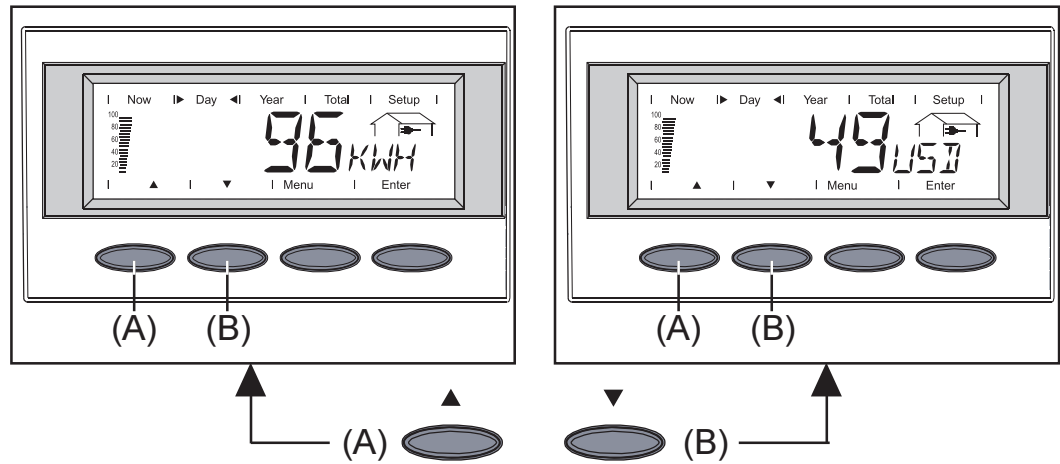

- select the desired display mode (see above)
- scroll between the display functions available with keys (A) or (B)

## Display Modes

### Display mode outline

The following display modes are available:

**display mode "Now"** ...shows present data

**display mode "Day"** ... shows data for the current day

























**display mode "Year"** ...shows data for current calendar year - only available in combination with Datalogger

**display mode "Total"** ... shows data since your FRONIUS IG unit first started operating

**Display symbol key**

The following table contains a brief list of the display readings available.

Display readings without an asterisk are shown even if no Datalogger or Sensor box is connected to the FRONIUS IG.

Mode "Now"	Mode "Day" / "Year" / "Total"
output power  (W)	energy supplied  (kWh / MWh)
voltage  (V)	yield  (set applicable currency)
output current  (A)	CO <sub>2</sub> -reduction  (lb / t)
grid frequency  (Hz)	maximum power output  (W)
module voltage  (V)	grid voltage (maximum)  (V)
module current  (A)	grid voltage (minimum)  (V)
* module temperature  (°F; also °C)	array voltage (maximum)  (V)
GFDI status 	* energy as read by consumption meter  (kWh / MWh)
* output reading of consumption meter  (W)	* module temperature (max.)  (°F; alternat. also °C)
* ambient temperature  (°F; also °C)	* module temperature (min.)  (°F; also °C)
* irradiance  (W/m <sup>2</sup> )	* ambient temperature (max.)  (°F; alternat. also °C)
* time (HH:MM)	* ambient temperature (min.)  (°F; alternat. also °C)
	* irradiance (max.)  (W/m <sup>2</sup> )
	operating hours of FRONIUS IG unit  (HH:MM)

\* optional - when the DatCom component for the required option is not available, the message "N.A." (not available) is displayed.

**Display mode  
"Now"**



Displays present readings

- select display mode "Now" (see the chapter "The Display")
- the first display reading of the display mode "Now" appears



(A) (B)

**AC power supplied** ...power supplied to grid at the particular moment (Watts)

- for the next item press key (B)
- to scroll back press key (A)



**AC grid voltage** (Volts)



**AC current supplied** .. current supplied to the grid at the particular moment (Amperes)



**grid frequency** (Hertz)



**DC array voltage**... voltage of the solar array at the moment of data display (Volts)



**DC array current** ... current supplied by solar array at the moment of data display (Amperes)



- \* **DC module temperature** ... temperature at solar modules (°F; can also be set for °C; this corresponds to temperature sensor No.1; Sensor Box and temperature sensor required)

Display mode  
"Now"  
(continued)



**GFDI status** ... if there is no ground fault in the system "OK GFDI" is displayed



\* **power drawn from the grid** ... present consumption (Watts; Sensor Box and load sensor required)



\* **ambient temperature** (°F; can also be set for °C in setup menu; this corresponds to temperature sensor No.2; Sensor Box and temperature sensor required)



\* **irradiance** ... the sunlight's power per square meter (Watts/m<sup>2</sup>; Sensor Box and irradiance sensor required)



\* **time of the day** (HH:MM, Datalogger required)

\* optional - if the DatCom component for the required options are not available, the message "N.A." (not available) is displayed.

**Display mode  
"Day / Year /  
Total"**



Display mode "Day" ... shows readings for the current day

- energy supplied (kWh)
- yield (currency can be selected)
- CO<sub>2</sub> reduction (lb)
- maximum power supplied (Watts)
- maximum grid voltage (Volts)
- minimum grid voltage (Volts)
- maximum module voltage (Volts)
- energy drawn from the grid (kWh)\*
- maximum module temperature (°F; alternatively °C)\*
- minimum module temperature (°F; alternatively °C)\*
- maximum ambient temperature (°F; alternatively °C)\*
- minimum ambient temperature (°F; alternatively °C)\*
- maximum irradiance (W/m<sup>2</sup>)\*
- operating hours for FRONIUS IG unit

\* optional - if the DatCom component for the required option is not available, the message "**N.A.**" (not available) is displayed.

**Important!** For the FRONIUS IG unit, the day begins when it switches on. If the DC supply line is disconnected, the parameters will be re-set after repeating the start-up.

This does not apply if a Datalogger is connected to the FRONIUS IG. If the Datalogger is available, the display values listed always apply for the whole day, beginning at 0:00am, ending at 0:00am the following day.



Display mode "Year" ...shows readings for the current calendar year, from January 1<sup>st</sup> (only in conjunction with Datalogger)



Display mode "Total" ...shows readings since original start of operation of the FRONIUS IG unit.

- select display mode "Day" / "Year" / "Total" (chapter "The Display")
- the first display function of the display mode selected will appear



**Display mode**  
**"Day / Year /**  
**Total"**  
 (continued)



(A) (B)

**Energy supplied ...** energy supplied during monitored period (kWh / MWh)

Due to the variety of different monitoring systems, there can be deviations between the readings of other metering instruments as compared to the readings from the FRONIUS IG. For determining the energy supplied to the grid only the readings of the calibrated meter supplied by the electric utility company are relevant.

- press (B) for next item
- to scroll back press (A)



**Yield ...** money earned during monitored period (set currency and price per kWh in setup menu)

**Important!** As was the case for the energy supplied, readings may differ from those of other instruments.

The chapter "The Setup Menu" tells how to set currency and rate applicable for invoicing. The factory setting is 0.14 US-Dollar (USD)/kWh.



**CO<sub>2</sub>-reduction ...** CO<sub>2</sub> emissions avoided during monitored period (lb/t)

The CO<sub>2</sub> meter gives an indication of CO<sub>2</sub> emissions (in lb/t) that would be released during the generation of the same amount of electricity in a combustion power plant. This is set for 1.3 lb/kWh in the factory.

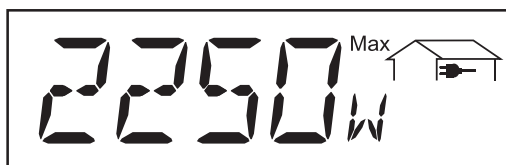

**Maximum output power ..** highest output power of the FRONIUS IG during observation period (W)



**Maximum grid voltage ...** highest reading of grid voltage (V) during observation period

Display mode  
"Day / Year /  
Total"  
(continued)



**Minimum grid voltage...**  
lowest reading of grid voltage  
(V) during observation period



**Maximum array voltage...**  
highest reading of array  
voltage (V) during observati-  
on period



\* **Energy consumption meter  
reading**  
energy consumed during  
observation period (kWh /  
MWh; Sensor Box and con-  
sumption sensor required)



\* **maximum module tempera-  
ture ...** highest temperature  
reading at solar modules  
during observation period  
(°F; can also be set for °C in  
setup menu; temperature  
sensor No. 1; Sensor Box  
required)



**NOTE!** Fit the temperatu-  
re probe near the solar  
module.



\* **minimum module  
temperature...** lowest tempe-  
rature reading at solar modu-  
les during observation period  
(°F; can also be set for °C in  
setup menu; temperature  
sensor No. 1; Sensor Box  
required)



\* **maximum ambient tempe-  
rature ...** highest ambient  
temperature reading during  
observation period (°F; can  
also be set for °C in setup  
menu; temperature sensor  
No. 2; Sensor Box required)

**Display mode**  
**"Day / Year /**  
**Total"**  
(continued)



\* **minimum ambient temperature...** lowest ambient temperature reading during observation period (°F; can also be set for °C in setup menu; temperature sensor No2; Sensor Box required)



\* **maximum irradiance...** highest irradiance during observation period (W/m<sup>2</sup>; Sensor Box and reference cell required)



**operating hours ...** duration of operation of FRONIUS IG unit (HH:MM)

Duration of operation is shown in hours and minutes up to 999 h and 59 min (display: "999:59"). From then on only full hours are displayed.

Although the FRONIUS IG unit does not operate during the night, all sensor data are recorded around the clock.

# The Setup Menu

## List of menu items

The diagram below shows the menu of adjustable parameters

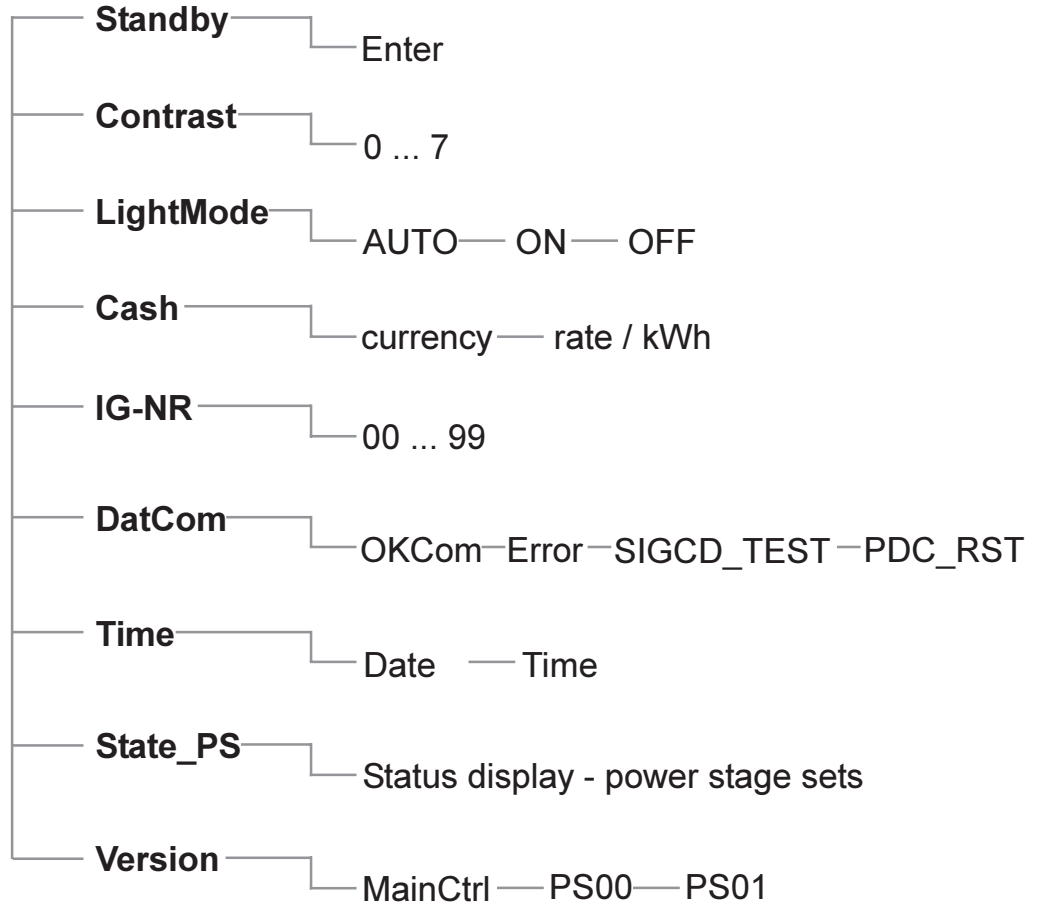

**Display mode  
"Setup"**

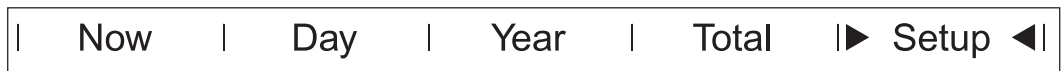

The setup menu allows easy readjustment of the FRONIUS IG's preset parameters to your needs.

**Enter the  
setup menu**

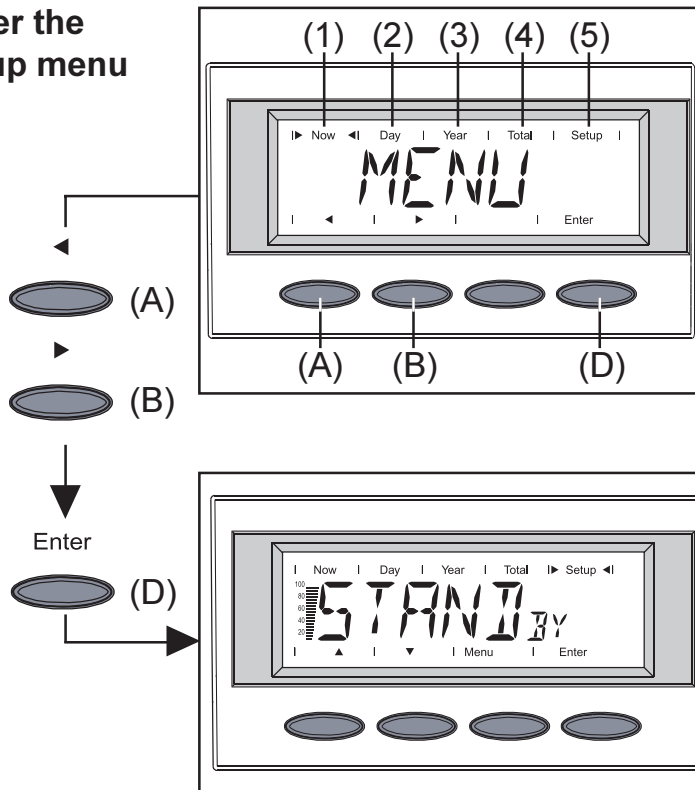

- move to the menu level (see the chapter "Navigating in the Display")
- select "Setup" mode (5) with (A) or (B) keys
- enter the mode "Setup" (5) by pressing the "Enter" key (D)

- "Standby" (the first item on the menu) is displayed

**Scroll among  
menu items**

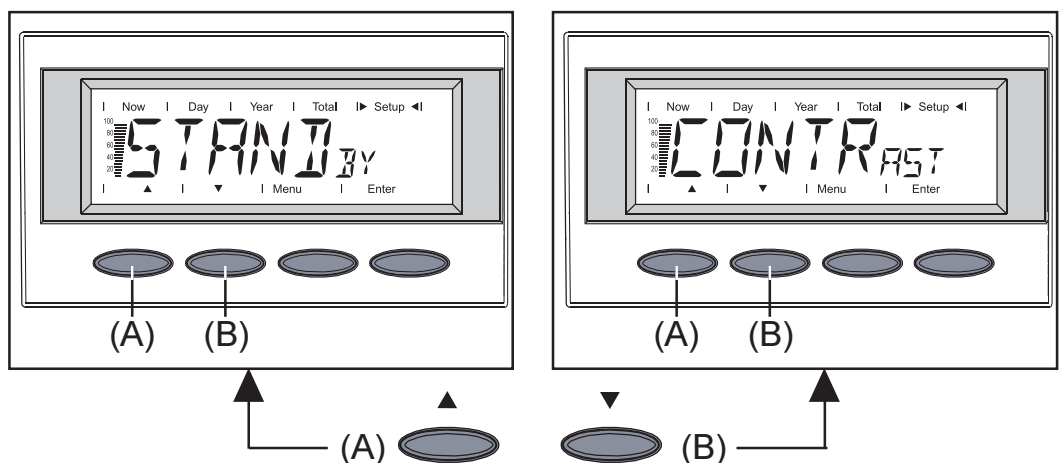

- select the desired display mode (see above)
- scroll with (A) or (B) keys among the menu items available

## Setting the menu items

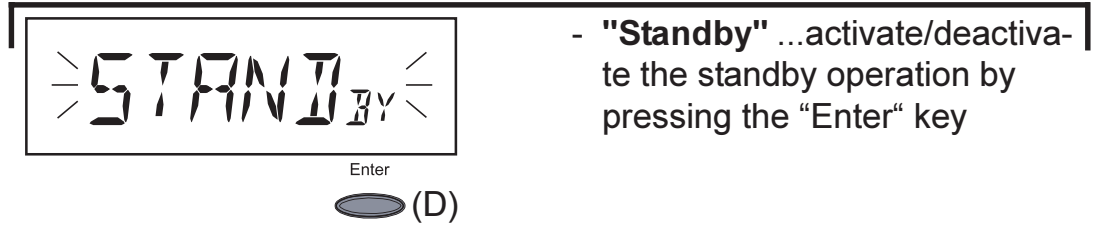

- **"Standby"** ...activate/deactivate the standby operation by pressing the "Enter" key

The menu item "Standby" allows manual activation of the standby operation of the FRONIUS IG unit. The standby mode is helpful when troubleshooting or adding/removing system components.

During standby operation the electronic system of the power stage is switched off. No power is fed into the grid. The LED flashes orange. The following message flashes intermittently on the screen:

"STANDBY" "ENTER"

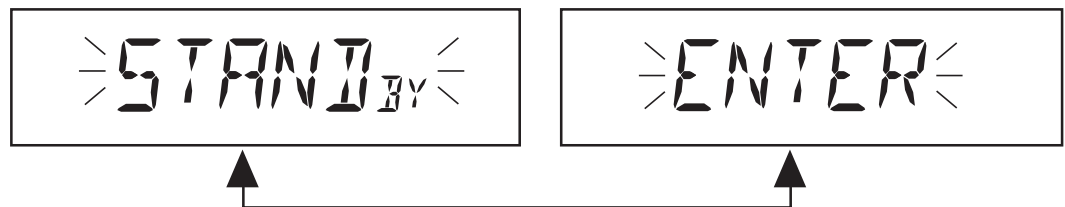

- The orange flashing LED stops at dusk.
- After the subsequent sunrise, the power supply operation into the grid is resumed automatically (after termination of the startup phase the LED is illuminated green)
- grid supply operation can be resumed at any time whenever the LED is flashing orange (deactivate "standby")

To activate standby:

- When the LED is green: activate "standby" (manual shutoff of operation supplying power into the grid):
  - press "Enter" key (D)

To deactivate standby:

- When the LED is flashing orange: deactivate "standby" (resuming operation supplying power into the grid)
  - press "Enter" key (D)

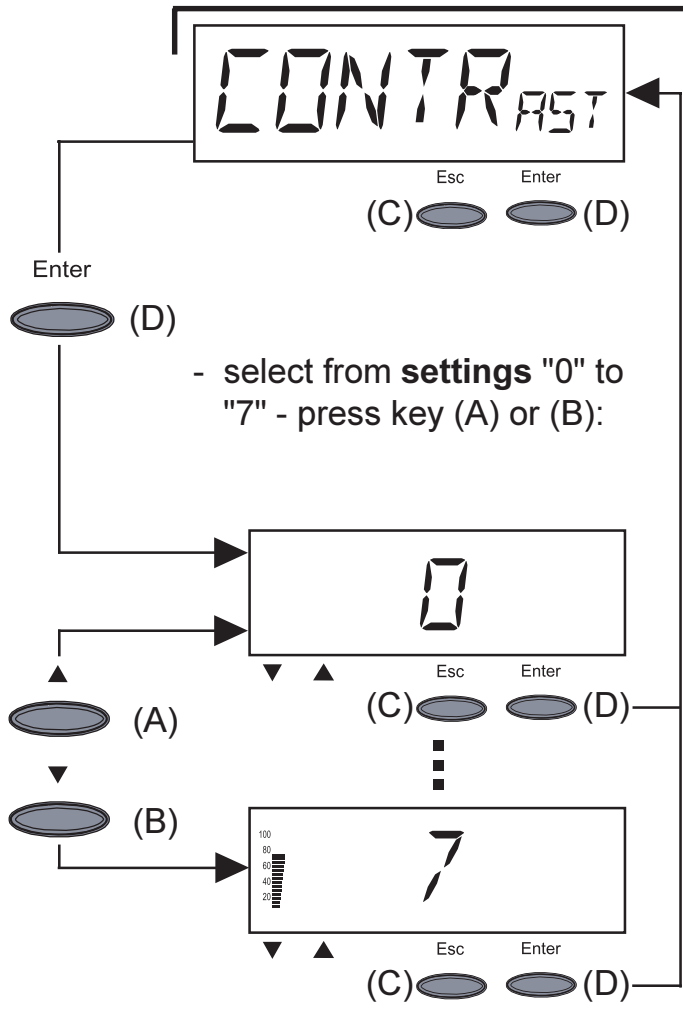

- "Contrast" ... set contrast on LCD display
- enter "Contrast": press "Enter" key (D)

Since contrast depends on temperature, it may be necessary to adjust the menu item "Contrast" when ambient conditions change.

**Settings** for minimum possible contrast (0) up to maximum possible contrast (7):

- accept: press "Enter" key (D)
- maintain previous setting: press "Esc" key (C)

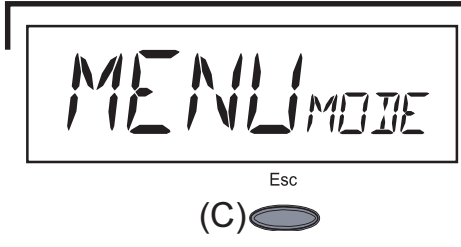

- "Menu Mode" ... cannot be selected

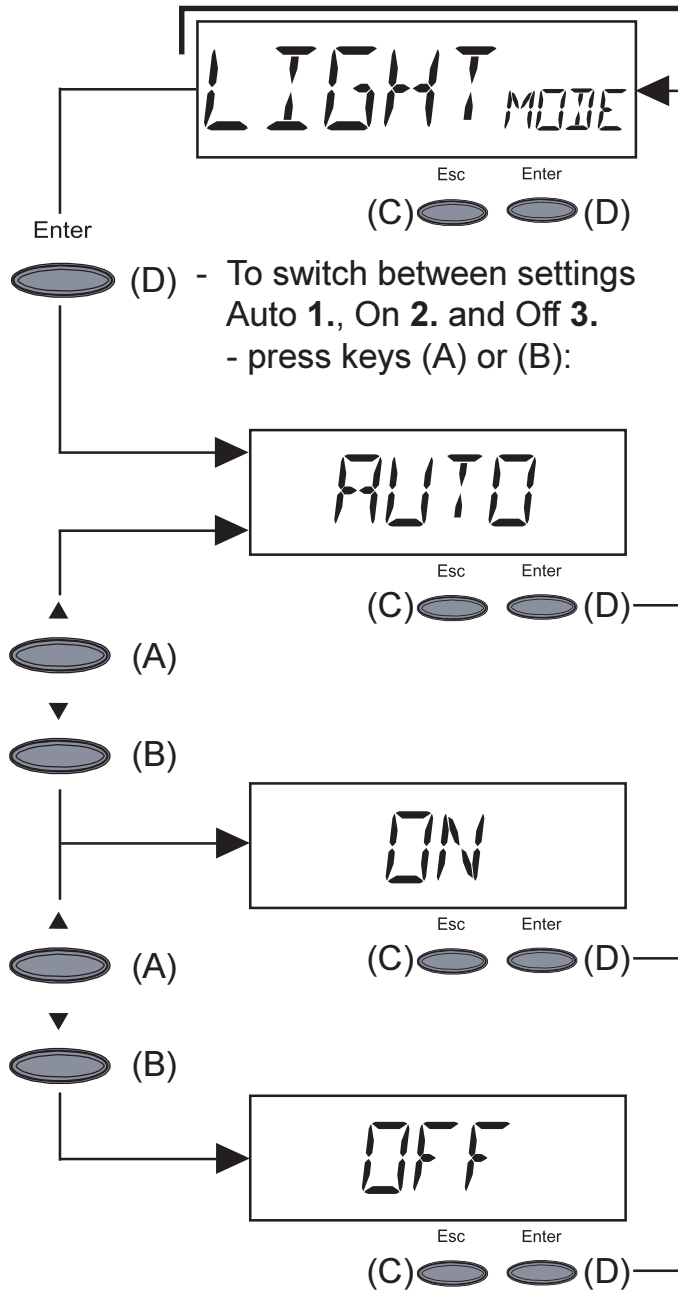

- "Light Mode" ... pre-setting of display illumination

- to enter "Light Mode": press "Enter" key (D)

1. The display illumination will stop 30 seconds after the last time a key has been pressed  
- accept: press "Enter" key (D)  
- maintain previous setting: press "Esc" key (C)

2. The display will continue to remain illuminated whenever power is supplied to the grid  
- accept: press "Enter" key (D)  
- maintain previous setting: press "Esc" key (C)

3. The display illumination will be permanently off:  
- accept: press "Enter" key (D)  
- maintain previous setting: press "Esc" key (C)

**Important!** These instructions are only applicable for the display background illumination. The LCD will still remain on during operation. Its energy consumption is less than one mW (1/1000 W).

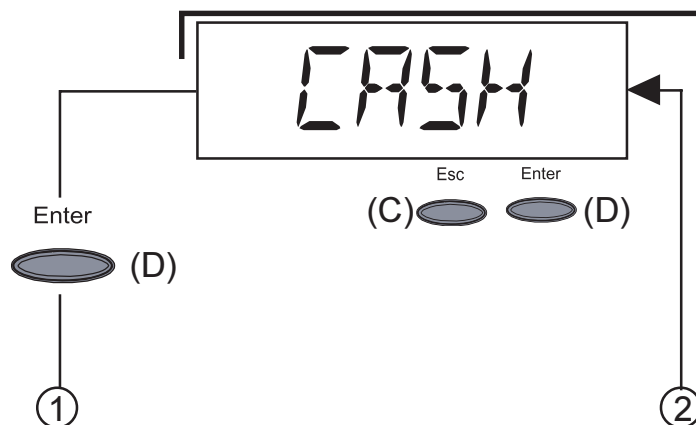

- "Cash" ... setting of currency and rate for invoicing the energy supplied

- enter "Cash" by pressing "Enter" key (D)



The name of the currency units can be changed. For example, here you see the units changed from the default US Dollars (USD) to Canadian Dollars (CAD).

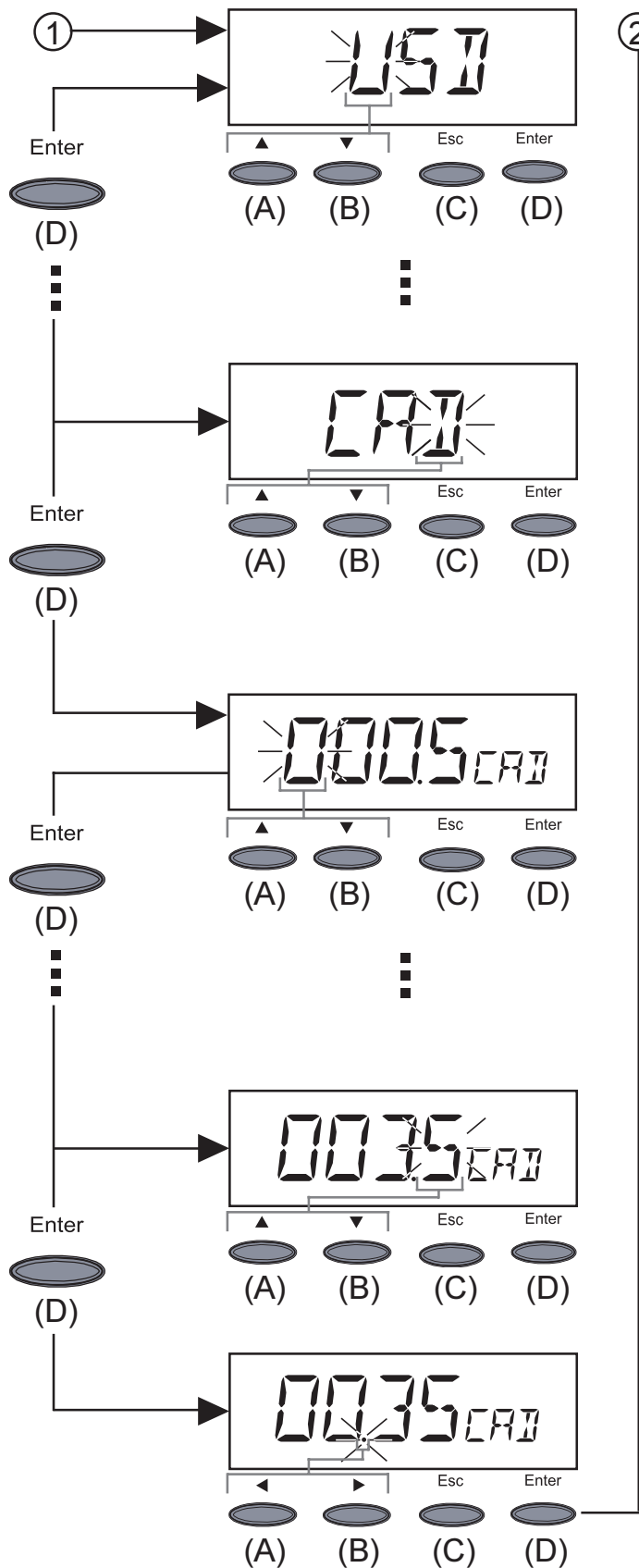

- ①
1. Enter currency (factory pre-set for US-Dollars - USD)
    - first digit starts flashing
    - select a character for the first digit by pressing key (A) or (B)
    - confirm by pressing "Enter" key (D)
    - next digit starts flashing
    - follow same procedure as described above for subsequent digits
    - accept the currency selected by pressing "Enter" key (D)
    - to maintain previous setting, press "Esc" key (C)

- ②
2. Enter rate per kWh according currency selected (preset rate: 0.14 USD/kWh)
    - first digit starts flashing
    - select a figure for the first digit by pressing (A) or (B) keys
    - confirm by pressing "Enter" key (D)
    - next digit starts flashing
    - for subsequent digits, follow same procedure as described above for first digit

- To move decimal point:
- decimal point starts flashing
  - move the decimal point to the position desired by pressing (A) or (B) keys
  - accept the rate set by pressing "Enter" key (D)
  - to maintain previous setting, press "Esc" key (C)

 **NOTE!** numbers between 000.1 and 99.99 may be selected

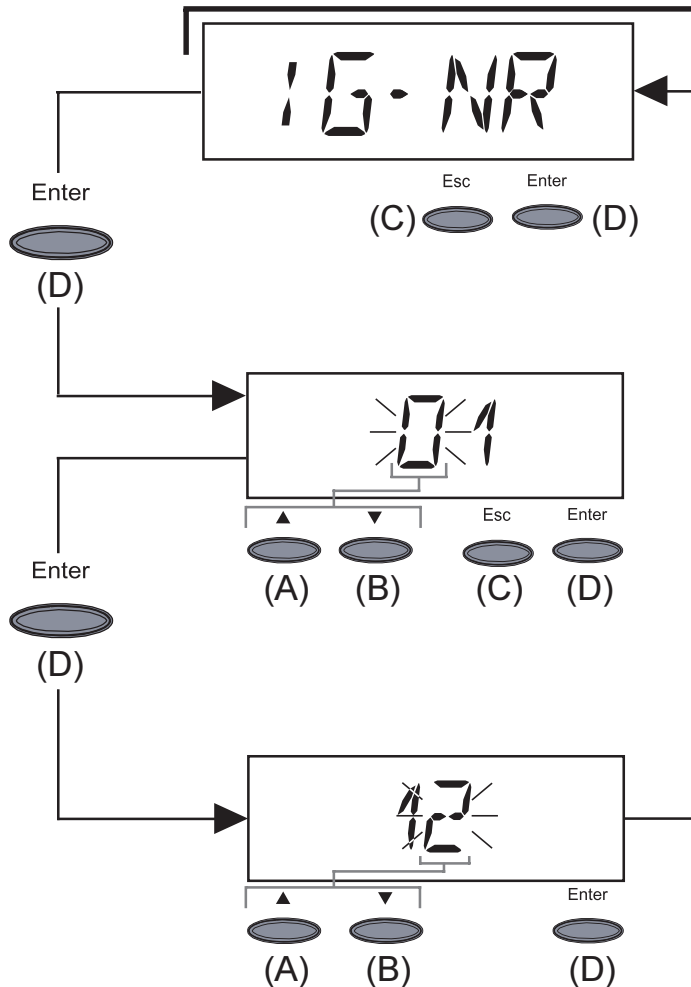

- "IG-NR" ...Setting the number (address) of the FRONIUS IG unit in a setup comprising multiple FRONIUS IG units linked together
- enter "IG-NR" by pressing the "Enter" key (D)
- enter address (00 ... 99)  
(factory setting: 01)
- first digit starts flashing
- select a figure for the first digit by pressing (A) or (B) keys
- confirm with "Enter" key (D)
- subsequent digit starts flashing
- for second digit follow procedure as described above for first digit

- accept the IG-No. selected: press "Enter" key (D)
- maintain previous setting: press "Esc" key (C)

**NOTE!** Allocate a different address to each FRONIUS IG when connecting several FRONIUS IGs into a data communication network using COM Cards and a Datalogger.

It is important to give each FRONIUS IG its own address so that the Datalogger can differentiate between the individual inverters. If two FRONIUS IGs are in the system with the same address, they cannot communicate with the Datalogger. In this case the service code 504 is shown on the display and the LED flashes green. Set the address on the other FRONIUS IG showing the state message 504.

**Important!** If your inverters have the same address this only will affect data communication and not the FRONIUS IG's power output.

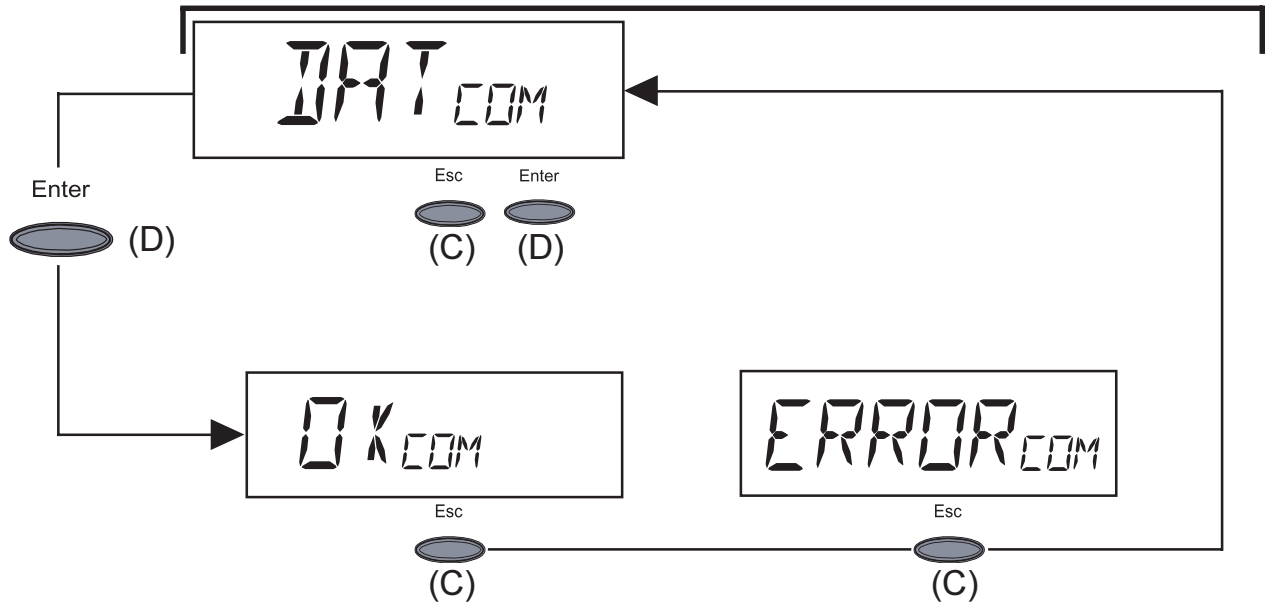

If a successful data link has been set up then "OK<sub>COM</sub>" is displayed.

"Error" is displayed if DatCom is not installed or the data link is not functioning correctly.

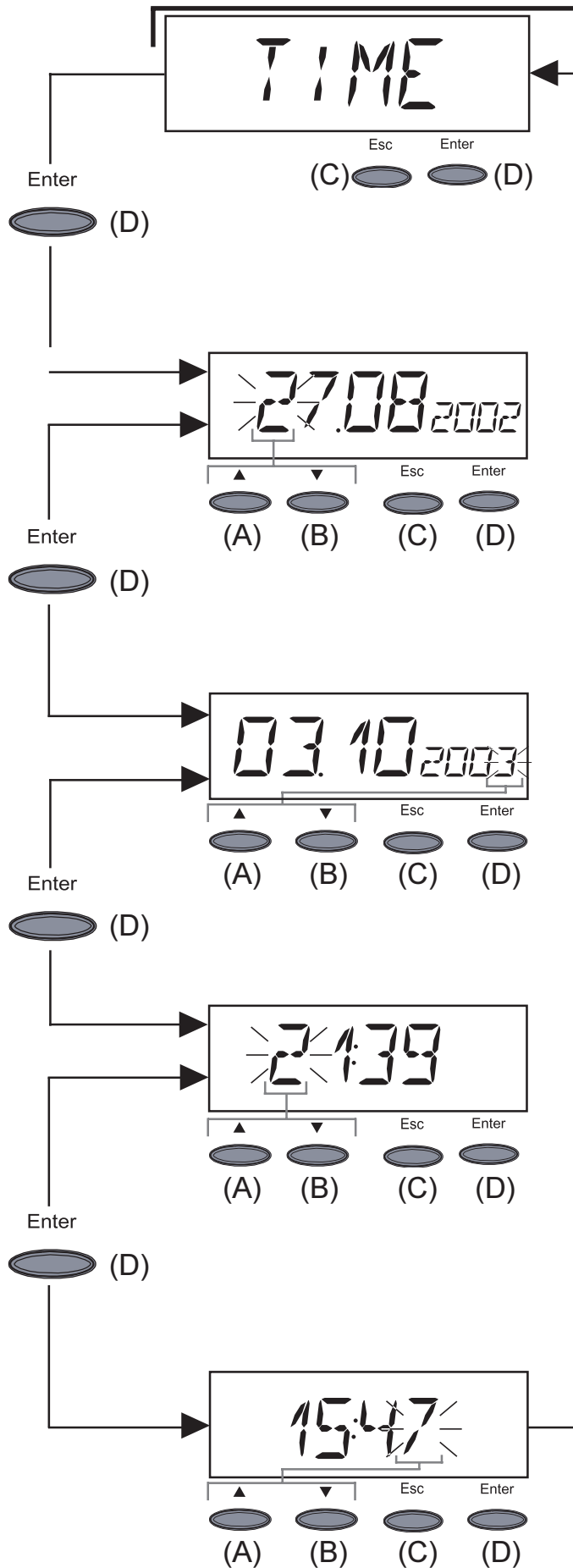

**NOTE!** The menu item "Time" is only supported when the FRONIUS Data-logger is connected.

- "Time" ... setting of date and time
  - enter "Time" by pressing "Enter" key (D)
- 1. Enter date (e.g.: 28.01.2006)**
- Date format is day, month, year
  - first digit starts flashing
  - select a character for the first digit by pressing (A) or (B) keys
  - confirm by pressing "Enter" key (D)
  - next digit starts flashing
  - follow the same procedure as described above for subsequent digits
  - accept the date selected by pressing "Enter" key (D)
  - to maintain previous setting, press "Esc" key (C)
- 2. Enter time (e.g.: 15:47)**
- US military time (24 hour clock)
  - first digit starts flashing
  - select a figure for the first digit by pressing (A) or (B) keys
  - confirm by pressing "Enter" key (D)
  - next digit starts flashing
  - for subsequent digits, follow the same procedure as described above for first digit
  - accept the time set by pressing "Enter" key (D)
  - to maintain previous setting, press "Esc" key (C)

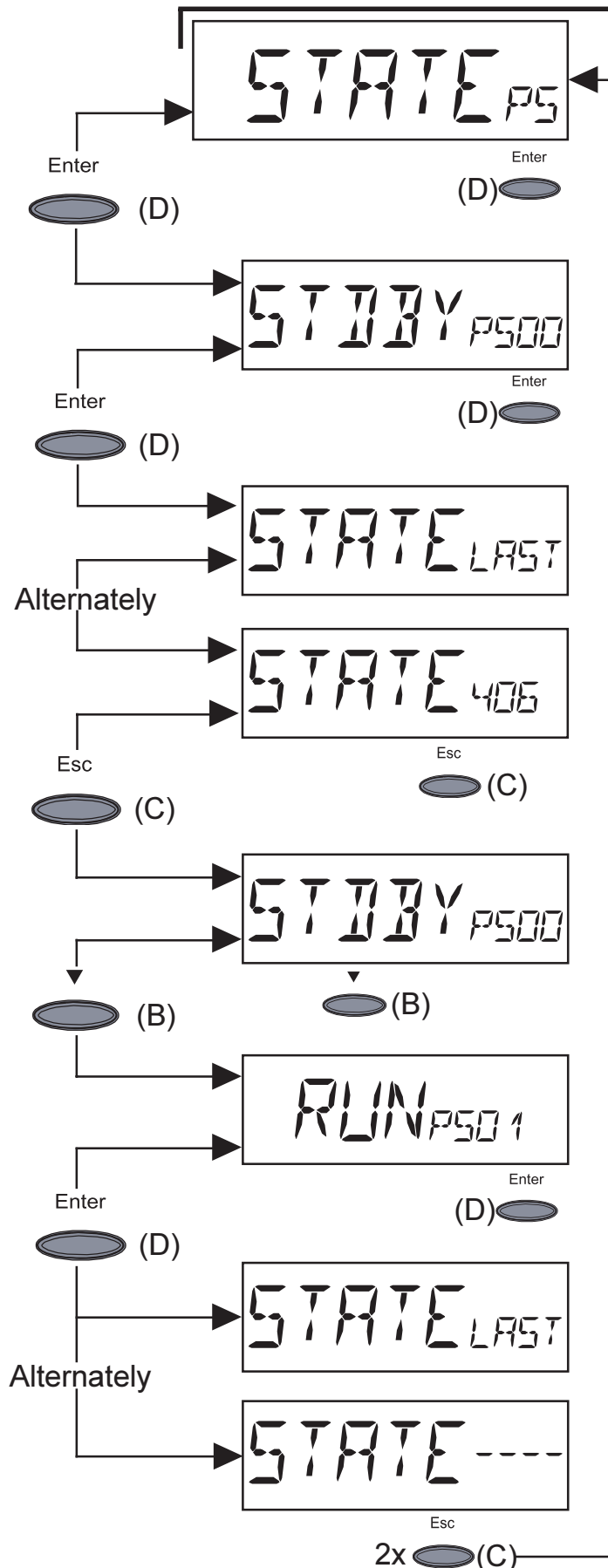

- "STATE\_PS" ... Status display of power stage sets
- Press "Enter key" (D)
- In this case, for example, the first power stage set (PS00) is on "Standby"
- "Standby" means no electricity is being fed into the public mains
- Press "Enter" key (D)
- Display of the most recently stored service code (e.g. "State 406")

**Important!** The most recently stored service code and the display "State Last" appear alternately.

- Press "Esc" key (C)
- The display for the first power stage set (PS00) re-appears
- Change over to the second power stage set by pressing key (B)
- In this case for example the second power stage set (PS01) is on "Run"
- "Run" means intact delivery of electricity to the public mains
- Press "Enter" key (D)
- Display of the most recently stored service code (e.g. "State----")

**Important!** The most recently stored service code and the display "State Last" appear alternately.

- Press "Esc" key (C) twice



**NOTE!** State 306 (Power Low) and 307 (DC-Low) appear naturally every morning and evening due to low solar irradiance. These status messages are not the result of a fault.

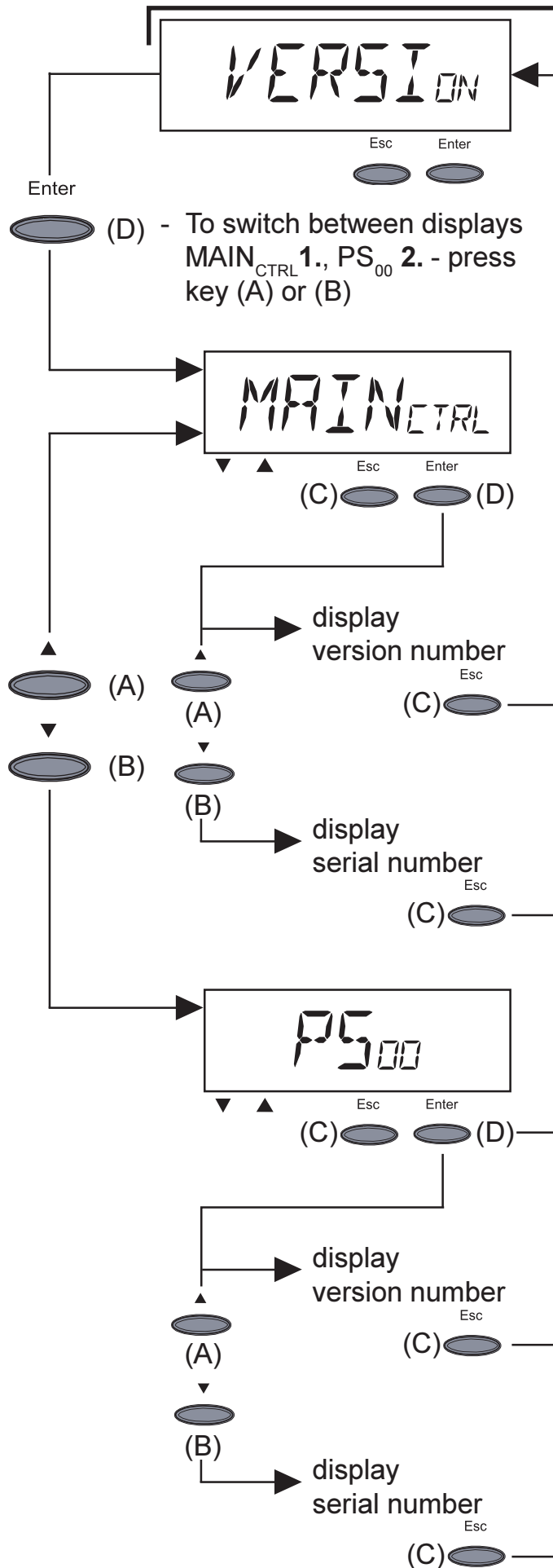

- **"Version"** displays version number of the IG control unit and the power stage

- enter "Version" by pressing "Enter" key (D)

**1.** For displaying version number of the IG control unit : press "Enter" key (D)

- exit by pressing "Esc" key (C)

- to switch into display of serial number for the IG control unit: press "(A) or (B)" keys

- exit with "Esc" key (C)

**2.** To display version number of power stage, press key "Enter (D)" - exit with key "Esc (C)"

- to switch into display of serial number of the power stage, press keys "(A) or (B)" - exit with key "Esc (C)"

# Additional information

## Upgrading the system

The FRONIUS IG unit is prepared for a whole series of system upgrades, such as:

- Communication between FRONIUS IG and DatCom units
- Dataloggers (for recording and managing your photovoltaic system data via personal computer), including Datalogger and modem connection
- Interface Card Easy sends all relevant working parameters in a well defined RS-232 protocol
- Personal Display FRONIUS IG
- Various large displays (FRONIUS IG Public Display)
- Sensors (temperature sensor / irradiance / electricity consumption meter / ...)

For more information on Fronius communication products, please refer to the individual product literature, [www.fronius-usa.com](http://www.fronius-usa.com).

Some system upgrades are offered as plug-in cards, similar to those on your personal computer.

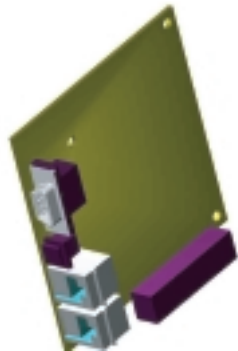

Other system upgrades are offered in external housings

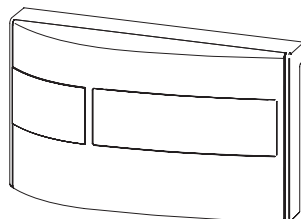

For unlimited system upgradeability, Fronius has developed the LocalNet. LocalNet is a data network that allows linking multiple FRONIUS IG units with data communication components.

LocalNet is a bus system. One single cable is sufficient to allow communication between one or several FRONIUS IG units with all system upgrade elements. This reduces the cable requirement to a minimum.

**Upgrading  
the system**  
(continued)

Please see further information in the chapter "LocalNet" of the installation and service manual.

**Forced ventilation**

The FRONIUS IG unit is equipped with a temperature controlled, variable speed fan that provides the following features:

- more compact housing - as a result of smaller heat sinks
- components are better cooled - efficiency increases / longer life
- least possible energy consumption / noise level, due to the variable speed control and ball bearing support
- should there be insufficient heat dissipation in spite of the fan operating at maximum speed (for example inadequate heat transfer away from the heat sinks) the power will be derated for protection of the FRONIUS IG unit.
- derating the power reduces the output of the FRONIUS IG unit for a short period sufficient to ensure that the temperature will not exceed the admissible limit.
- your FRONIUS IG unit will remain ready for operation as long as possible without any interruption.



# Installation manual

# Installation

## Installation instructions

These installation instructions serve as a manual for qualified electrical professionals and detail the installation, initial operation, status diagnosis and repair processes. It is in your interest to read the operating instructions thoroughly and follow the instructions it contains. In so doing you will avoid malfunctions resulting from incorrect operation.

## Safety



**WARNING!** Work performed incorrectly can cause serious injury and damage.

- Read the installation instructions carefully before installing the FRONIUS IG.
- Only a qualified electrical professional is authorized to carry out the installation of the FRONIUS IG.

## General information

Your FRONIUS IG is the latest generation of solar inverter. It is the highly complex link between your solar modules and the grid. As such, it is in charge of a number of highly technical tasks. The following diagram should give you a brief overview of a PV system including a FRONIUS IG.

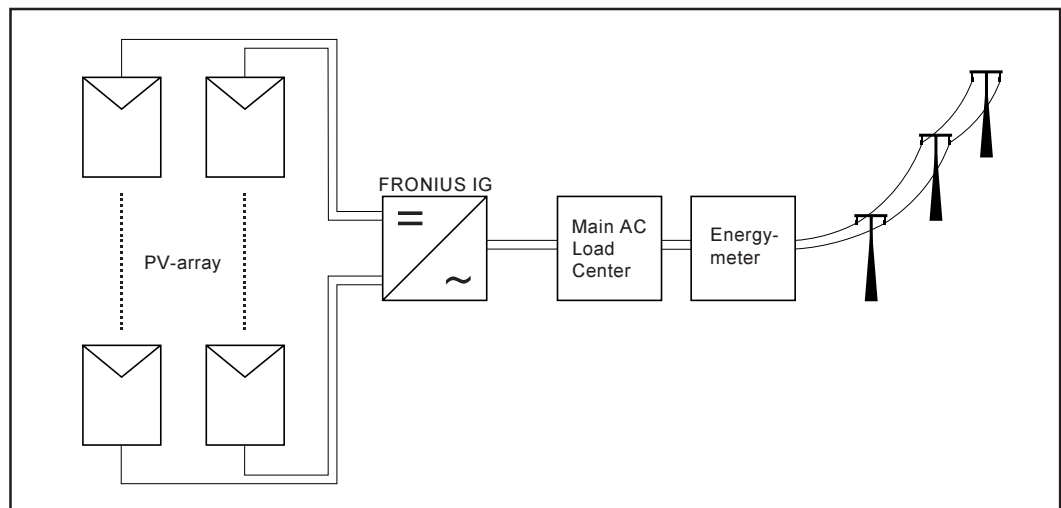

## **Choosing the location general**

To get the most out of your FRONIUS IG unit, observe the following rules:

- Limit grid impedance by using an appropriately-sized AC conductor between the FRONIUS IG unit and the in-house distribution panel. The AC conductor cable resistance between the FRONIUS IG unit and the house distribution panel should not exceed 0.5 Ohm. This can be achieved by using the following cable-sizes (according to NEC handbook, chapter 9, table 8):
  - AWG 10: maximum 200 ft. (60 m)
  - AWG 12: maximum 126 ft. (38 m)
- Only install it on a solid vertical wall at a minimum of 3 ft. (0.9 m) above the ground and to a maximum of 6.5 ft. (2 m)
- The ambient temperature should not be below -4 °F (-20 °C) or over 122 °F (50 °C).
- No objects are to be located within a distance of 6 in. around the air vents on both sides of the FRONIUS IG unit.
- When installing more than one unit, keep a distance of 8 in. between each FRONIUS IG.
- The air flow direction within the inverter is from left to right (cold air intake on left, hot air exit on right).
- When installing the FRONIUS IG unit in a switch panel cabinet (or similar closed environment) it is necessary to make sure that the hot air that develops will be discharged by forced ventilation.

## **Choosing the location**

- during certain operation phases the FRONIUS IG unit may produce a slight noise. For this reason it should not be installed in an occupied living area
- the FRONIUS IG unit is not to be set up in areas with large amounts of dust. If unavoidable, place the FRONIUS IG in an appropriately rated and ventilated box.
- the FRONIUS IG unit is not to be set up in areas with large amount of conducting dust particles (for example iron filings)
- the FRONIUS IG unit is to be installed at a height that keeps the display slightly below eye level for best possible readability of the display.
- NEMA 3R protection means that the FRONIUS IG can be exposed to moisture. However, we recommend that direct moisture be avoided, if possible.
- In spite of the NEMA 3R protection system, the FRONIUS IG should not be exposed to direct sunlight, as this could result in temperature derating.

## Preparing the wall mounting

The following describes how the FRONIUS IG is mounted to the wall. As your FRONIUS IG is delivered, the mounting plate is fixed to the inverter by two screws on the bottom of the FRONIUS IG.

For mounting the inverter to the wall proceed as follows:

- Loosen the screws (1) on the bottom of the inverter and remove the mounting plate (2)
- Fix the mounting plate (2) to the wall using four suitable screw anchors (3) and screws (4)

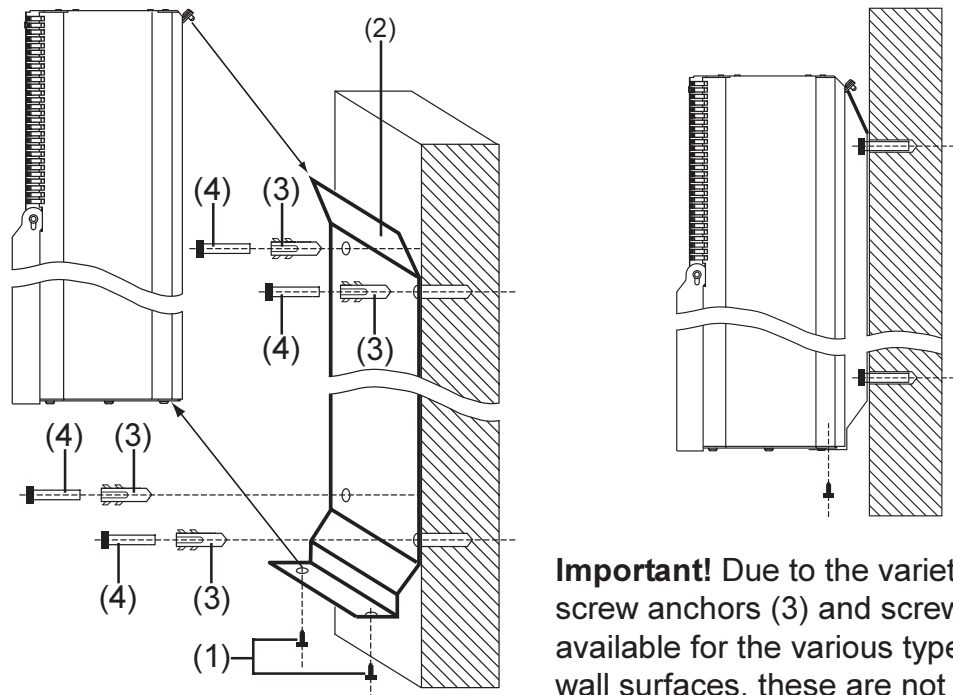

**Important!** Due to the variety of screw anchors (3) and screws (4) available for the various types of wall surfaces, these are not included.

In most cases, you should use 1/4 in. or 5/16 in. stainless steel or aluminum screws capable of supporting 26 lbs (FRONIUS IG 2000, 3000 and 2500-LV) or 42 lbs (FRONIUS IG 4000, 5100 and 4500-LV) of inverter weight. Triangulate the positions of these on the mounting plate using the pre-drilled holes when possible. Three vertically aligned holes for single stud mounting will suit most installations.

**CAUTION!** The FRONIUS IG may become dislodged and fall from the mounting plate if the unit is not fixed to the mounting plate using the two screws at the bottom (that were removed at the beginning).

**NOTE!** If you modify the FRONIUS IG enclosure with custom openings you will be required to return the unit for repair in the event of a warranty-related issue rather than doing an inverter exchange. Knockouts for grounding electrode may be required by local authorities.

- Slide the FRONIUS IG from above so that the unit may hang from the top of the mounting plate (2)
- Attach the FRONIUS IG to the bottom of the mounting plate (2) by using the screws (1) that were removed before

# Connection

## Safety

### General



**WARNING!** Hazard due to supply voltage and DC-voltage from the solar modules. Only qualified electrical professionals are authorized to open the connection area of the FRONIUS IG and only provided that it is not under voltage.



**WARNING!** An electric shock can be fatal. Inadequately sized electrical components can cause serious injuries to persons and damage to (or loss of) property.

- Electrical installations must be in accordance with the National Electrical Code, ANSI/NFPA 70.
- Use minimum AWG 12 (AC) and AWG 8 (DC), min. 167 °F (75 °C), copper wire for the connection of the FRONIUS IG 2000, 3000 and 2500-LV
- Use minimum AWG 10 (AC) and AWG 8 (DC), min. 167 °F (75 °C), copper wire for the connection of the FRONIUS IG 4000, 5100 and 4500-LV
- Use minimum AWG 10, min. 167 °F (75 °C), copper wire for all grounding cables.

## Connection to the Solar Modules and to the Utility Grid

### Solar modules

When selecting your solar modules to use with the FRONIUS IG unit, keep in mind this critical point: The open circuit voltage increases when temperature decreases (assuming constant irradiance). Therefore, at 14 °F (-10 °C) the open-circuit voltage must not exceed 500 V.

- Whenever the open-circuit voltage of the solar modules exceeds 500 V, the FRONIUS IG unit may be damaged, and all warranty rights will become null and void.
- More exact data for sizing the solar array for the particular location can be obtained using calculation tools such as the FRONIUS IG System Configuration Tool (available on [www.fronius-usa.com](http://www.fronius-usa.com)).
- See NEC table 690.7 for the appropriate code-related voltage adjustment factor for crystalline silicon modules, or use the manufacturer's specified voltage coefficient.

## Grid connection

Your FRONIUS IG unit needs to be connected to the DC/AC Disconnect Switches and to the equipment grounding according to the enclosed diagrams.

Your FRONIUS IG is equipped with a PV and Utility disconnect switch that switches AC and DC separately.

Depending on the installation, an external AC and/or DC disconnect may be required if the inverter is installed in a location not easily accessible to utility or fire personnel. Consult local authorities for additional information.



**WARNING!** In order to ensure the best possible operation of the grid monitoring system, it is important to make sure that there is minimal resistance in the lines to the connection point. The AC conductor resistance between the FRONIUS IG unit and the building's distribution panel should not exceed 0.5 Ohm.

The FRONIUS IG comes from the factory pre-configured for grid connection with neutral. The FRONIUS IG may be reconfigured for grids without neutral by setting the jumper on the PC-board as shown in the figure.



**NOTE!** The neutral conductor is not bonded to ground internally.

**Important!** Open the connection area as explained in the section „Connection“.

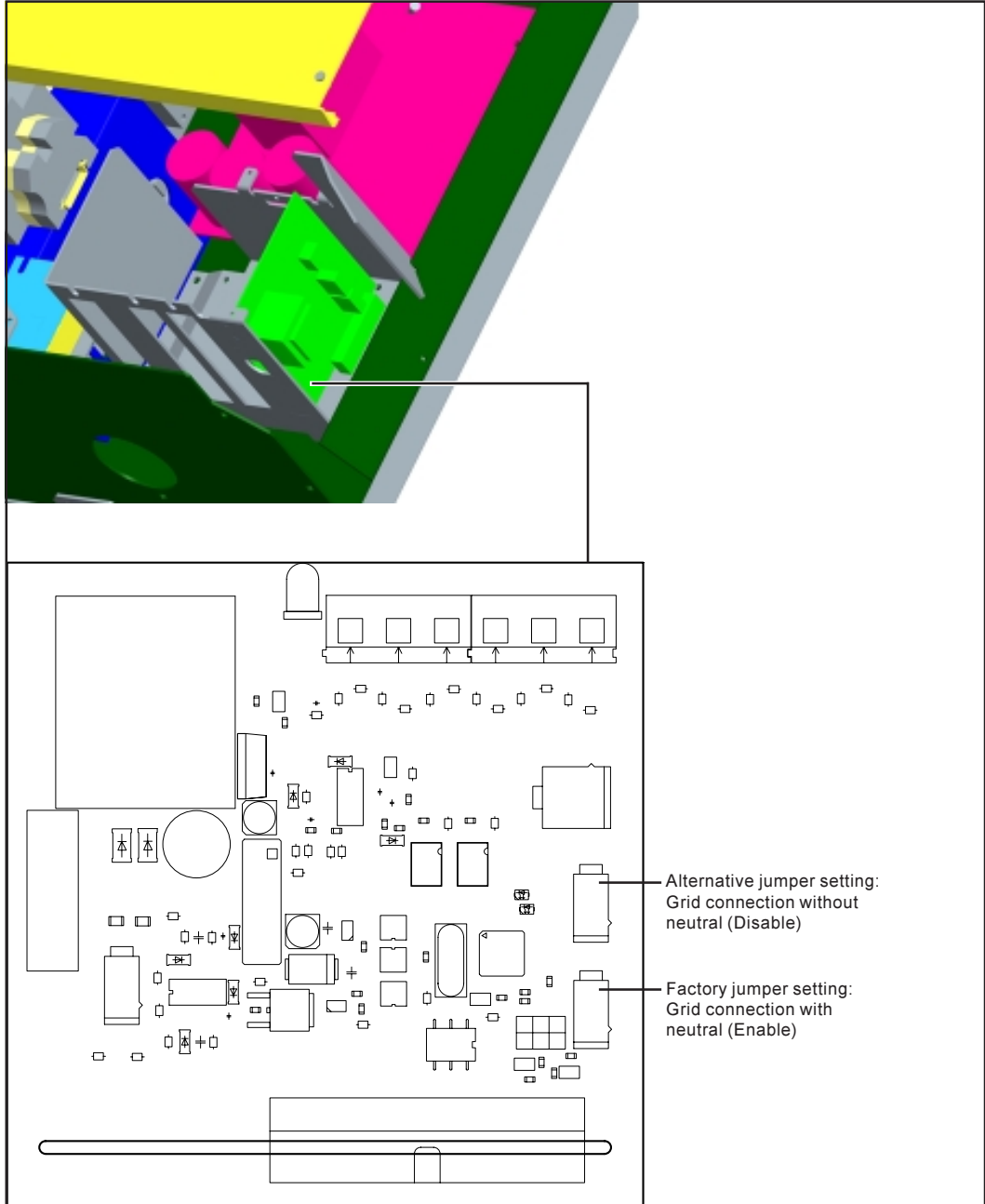

**Grid connection**  
(continued)

The following grid configurations are possible:

208 V Delta : 120 V WYE

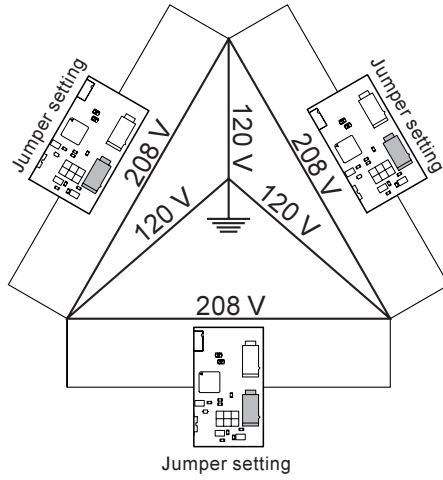

240 V : 120 V Split Phase

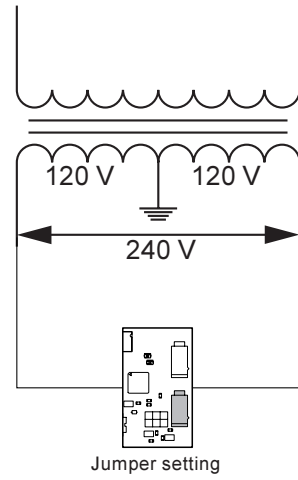

240 V Delta : 120 V Stinger

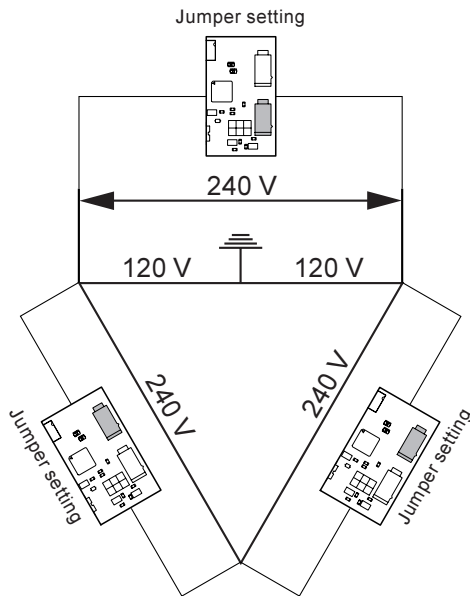

240 V Delta

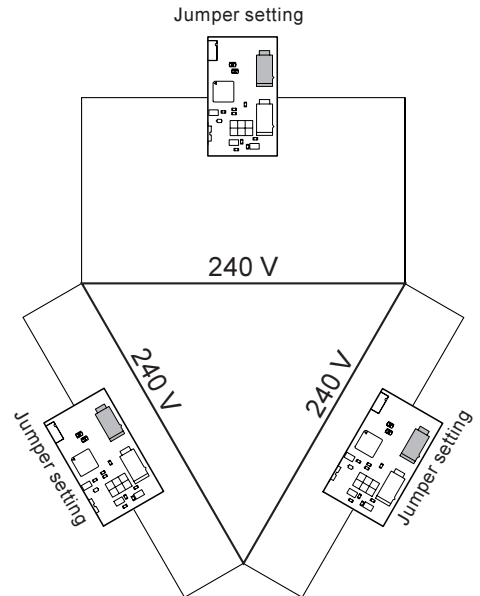

208 V Delta

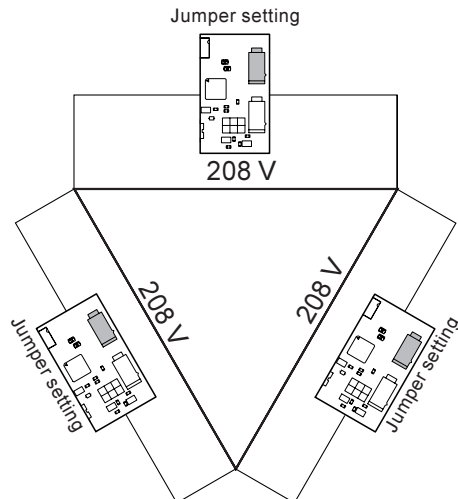



**Schemes with more than one inverter**

For larger photovoltaic schemes it is possible to connect several FRONIUS IG units in parallel without any problems.

**NOTE!** The FRONIUS IG 2500-LV and FRONIUS IG 4500-LV is designed to be connected to three phase systems. Utilities generally allow up to 6kVA of unbalance but check with your utility & try to balance the installation. The connection to the grid shall be done in the following way:

- Connect FRONIUS IG 1, 4, 7, ... to L1 and L2
- Connect FRONIUS IG 2, 5, 8, ... to L2 and L3
- Connect FRONIUS IG 3, 6, 9, ... to L1 and L3

The connection of the FRONIUS IG to the solar modules and the grid is described within the following chapter and shown in the next figure:

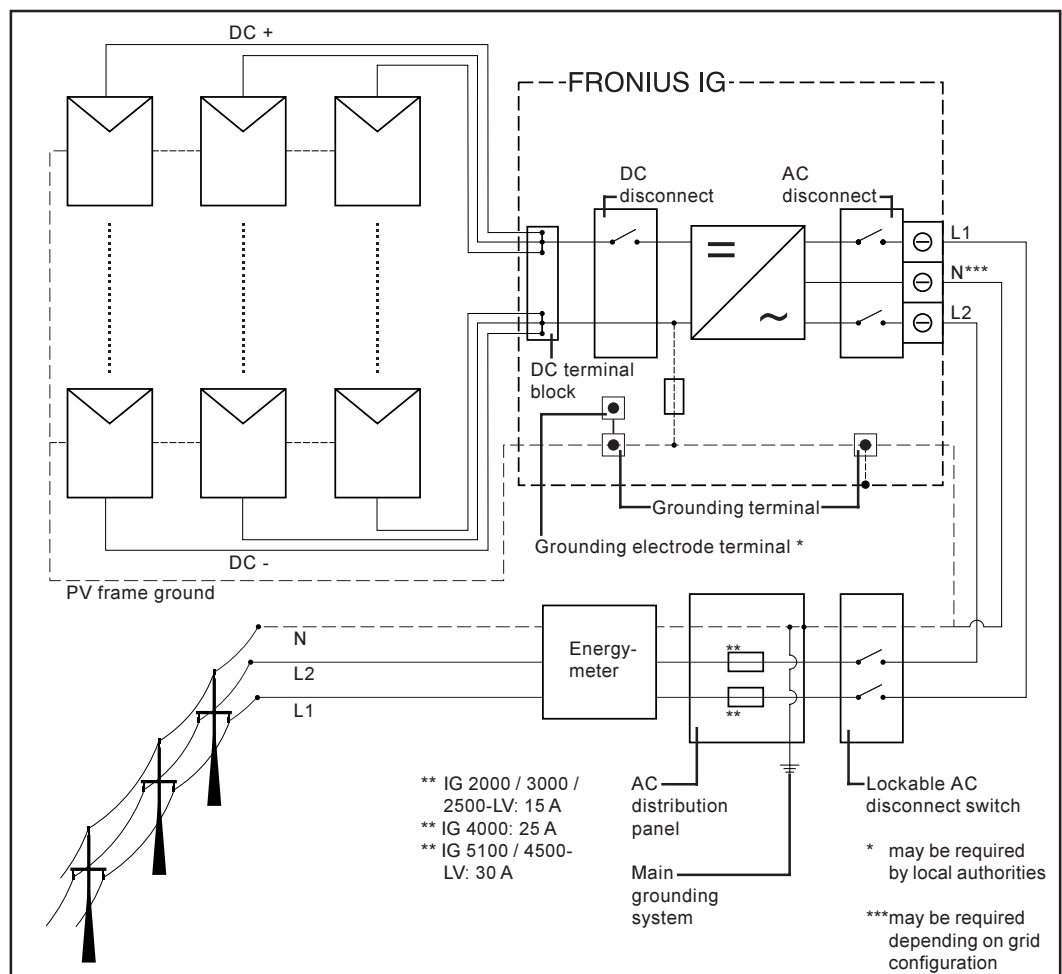

## Connection

- Fix the FRONIUS IG unit to the wall as shown in the "Installation" chapter.
- Open the connection area as shown in the figure.

**⚠ WARNING!** Hazard due to supply voltage and DC-voltage from the solar modules. Only qualified electrical professionals are authorized to open the connection area of the FRONIUS IG and only provided that it is not under voltage.

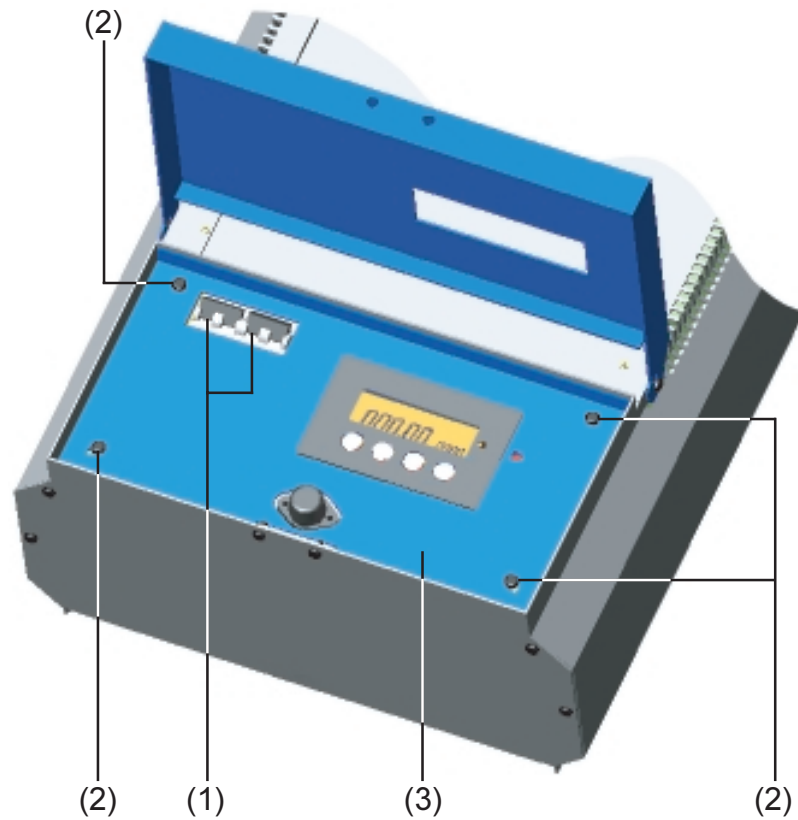

- set the internal AC- and DC disconnects (1) to the "OFF" position
- remove the four screws (2) on the IG's faceplate as shown in the figure above

**👉 NOTE!** When removing the LCD faceplate covering the connection area do not pinch, bend or strain the ribbon cable for the LCD.

- remove the LCD faceplate (3) covering the connection area

## Connection (continued)

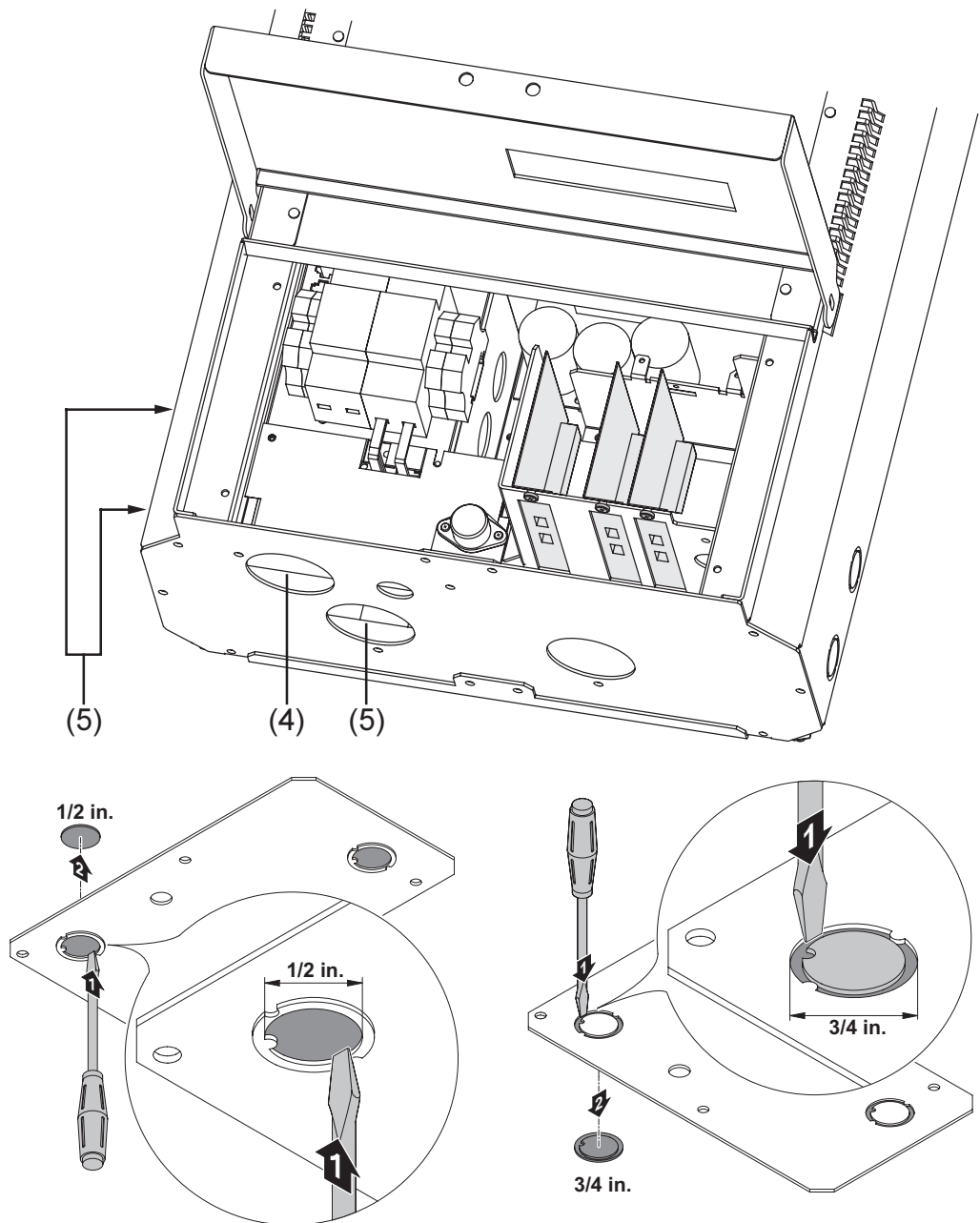

**NOTE!** When drilling holes for conduit fittings with a diameter exceeding 3/4 in., remove the connecting plate as shown in the figure.

- Insert a 1/2 or 3/4 in. conduit fitting in the knockout labeled "AC" (4) and fasten it
- Insert a 1/2 or 3/4 in. conduit fitting in the knockout labeled "DC" (5) and fasten it

**NOTE!** Only use raintight conduits according to UL 514B for the AC, DC and the optional DatCom knockouts.

**Connection**  
(continued)

**CAUTION!** To reduce the risk of fire, connect only to a circuit provided with branch circuit overcurrent protection in accordance with the National Electrical Code, ANSI / NFPA 70, at a MAXIMUM of:

- 20A ... IG 2000 / 3000 / 2500-LV (15 A is permissible)
- 30A ... IG 4000 / 5100 / 4500-LV (25 A is permissible with the IG 4000)

The next figure shows the connection area of the FRONIUS IG. The white plastic divider that separates the AC from the DC connection area is not shown in the figure.

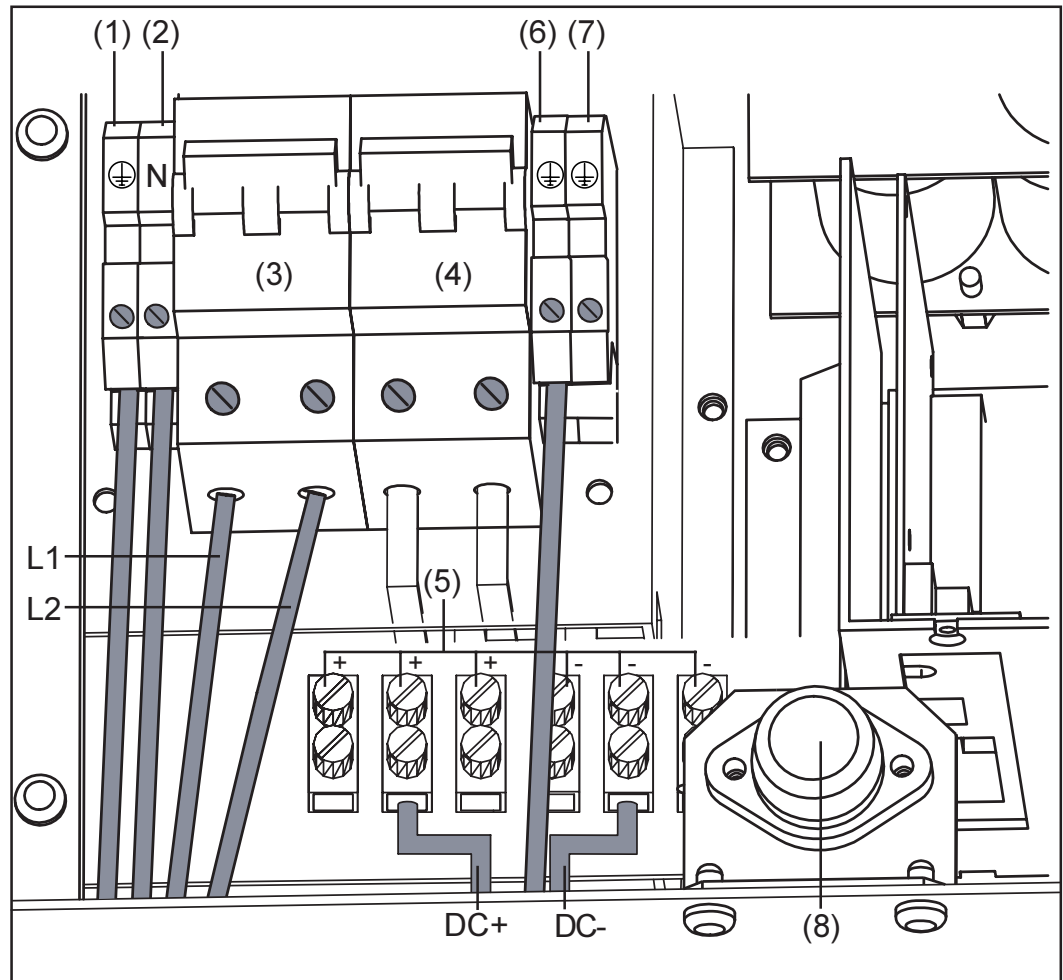

- |                            |   |
|----------------------------|---|
| (1) Equipment ground       | (6) PV frame ground   |
| (2) N - (Neutral) terminal | (7) Grounding electrode terminal<br>(may be required by local code) |
| (3) AC-disconnect          | (8) GFDI fuse   |
| (4) DC-disconnect          |   |
| (5) DC-terminal block      |   |

## Connect DC

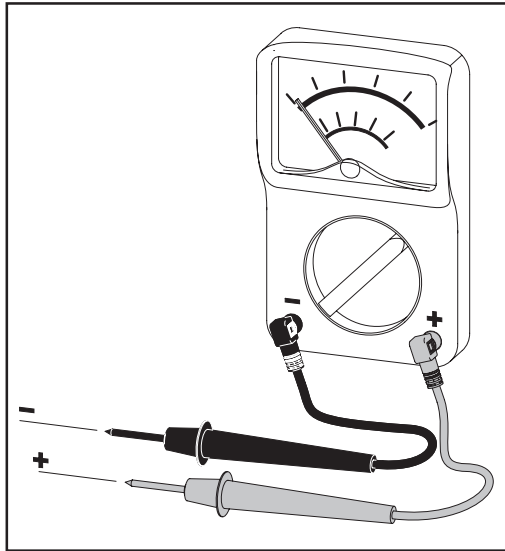

**NOTE!** Connecting the DC wiring with the wrong polarity may cause damage to the inverter. Connect the DC cables as described in the following instructions.

Check both the polarity and the open circuit voltage. The DC Voltage must not exceed 500 V, regardless of temperature.

**NOTE!** To access the DC terminals, the white plastic divider needs to be bent upward or rotated out of the way.

- Insert the DC cables through the DC conduit and connect them to the terminal block.
- Connect the positive (+) cables to the "DC+" terminals, and the negative (-) cables to the "DC-" terminals and tighten them with a torque of 1.7 ft. lbf.

**NOTE!** It is possible to connect up to 3 PV-strings in parallel within the FRONIUS IG 2000, 3000, 2500-LV, 4000, 5100 and 4500-LV.

**NOTE!** Do not connect the ground to the DC negative at any point! This is already done within the FRONIUS IG. If the DC negative is connected to ground at the DC terminal block or prior, this will circumvent the GFDI protection system, preventing your FRONIUS IG from properly detecting a fault current. Additionally, turning the DC disconnect to the off/open-circuit condition will not disconnect the array from ground, as it only disconnects the DC positive.

- Connect the module frame ground wire to the second terminal (6) labeled  $\oplus$ .

**Important!** Use minimum AWG 10, min. 167 °F (75 °C), copper wire for all grounding cables.

- Tighten wires with a torque of 1.7 ft. lbf.
- For your convenience, an additional grounding electrode terminal (7) is provided in case local regulations require additional grounding measures.

## Connect AC

- Insert the AC cables through the AC conduit and connect them to the AC terminals labeled "L1", "L2" and „N“, as well as to the ground terminal (1), labeled ⊕.



**NOTE!** Use minimum AWG 10, min. 167 °F (75 °C), copper wire for all grounding cables.

- Torque wires with a torque of 1.7 ft. lbf.
- Close the connection area
- Switch DC disconnect to the "ON" position
- Switch AC disconnect to the "ON" position

# Start up Operation

## Configuring your Inverter

### Factory pre-set configuration

Your FRONIUS IG unit has been pre-configured in the factory and is ready for operation.

After mounting the FRONIUS IG unit to the wall and connecting it to the solar modules (DC) and to the grid (AC), all you have to do is turn on the AC and DC circuit disconnects.

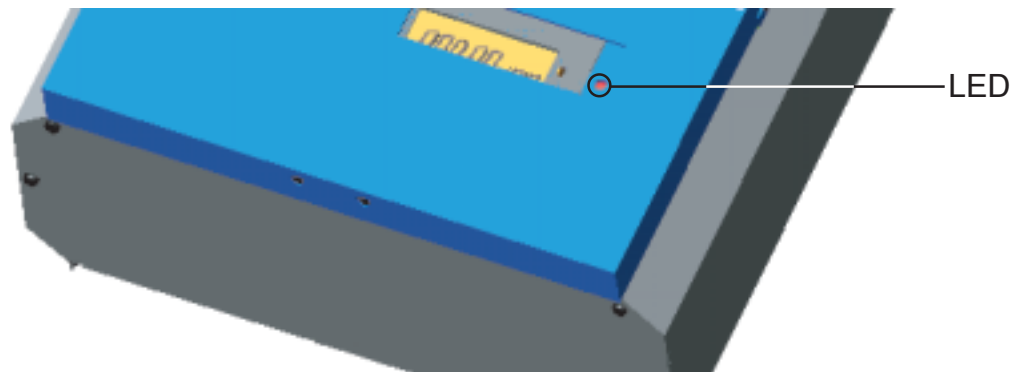

- as soon as the photovoltaic modules produce sufficient power, the status LED lights up orange and the screen displays the startup procedure
- the orange LED indicates that the feed-in mode of the FRONIUS IG will begin shortly
- after the FRONIUS IG unit has started feeding the energy into the grid, the LED light turns green
- the LED light continues green as long as power is fed into the grid. This confirms that the FRONIUS IG is operating properly and feeding energy into the grid.

## Factory pre-set configuration

(continued)

In case the initial operation of your FRONIUS IG unit does not proceed as shown above and the FRONIUS IG unit does not start feeding power into the grid, consult the chapter "Error Diagnosis and Repair".

## Your personal configuration

To change your inverter settings, please consult the chapter entitled "Operating Scheme", in the "Setup Menu" section of your operating instructions.

# Ground fault indication

## General



**WARNING!** An electric shock can be fatal. Normally grounded conductors may be ungrounded and energized when a ground fault is indicated. The ground fault has to be repaired before operation is resumed.

The FRONIUS IG is equipped with a ground-fault detection and interruption (GFDI) circuit as required by UL 1741 and the National Electrical code. The array's negative conductor is connected to the grounding system in the inverter. If a ground fault occurs in the DC cabling, the inverter disconnects from the grid. The fault is indicated by the red ground-fault LED and the service code "434" is shown on the display. In this situation, the FRONIUS IG is blocked from reconnection to the grid until the following actions are taken:

- Turn the AC and DC disconnect to position OFF (open-circuit)
- Remove the ground fault in your photovoltaic system
- Test the GFDI fuse and replace if necessary



**NOTE!** When a defective fuse is changed, only replace it with a "Littlefuse KLKD 1 AMP 600V" fuse.

- Turn the AC and DC disconnect to position ON (closed circuit)

# LocalNet

## System upgrading / plug-in card system

Your FRONIUS IG can be upgraded through the addition of several DatCom components for data monitoring:

- Datalogger (for recording and managing the data of your photovoltaic system on your personal computer, including modem tie in)
- Interface Card Easy sends all relevant working parameters in a well defined RS-232 protocol
- Personal Display FRONIUS IG
- Various large displays (FRONIUS IG Public Display)
- Sensors (temperature sensors / irradiation sensors / ...)

FRONIUS has developed the LocalNet to provide unrestricted individual use of the system's upgrades.

For more information on Fronius communication products, please refer to the individual product literature, [www.fronius-usa.com](http://www.fronius-usa.com).

For complete installation instructions on the DatCom system, please see the DatCom Manual provided with your FRONIUS Datalogger. This information is also available on the web at „[www.fronius-usa.com](http://www.fronius-usa.com)“.

## Datalogger

The Datalogger is the core of the LocalNet. It coordinates data transmission and ensures quick and safe distribution and storage of large volumes of data.

## COM Card

In order to connect the FRONIUS IG unit to the LocalNet, a COM Card is required

- COM Card ..... for exchanging data between your FRONIUS IG unit and the LocalNet.

The COM Card has the following connection terminals:

- 2 x RJ45 sockets labelled "IN" and "OUT" for connection of CAT 5 cables
- Power supply socket for the connection of 12 V low voltage power pack (only necessary in certain cases as described in the FRONIUS IG DatCom manual).

If the COM Card is to be installed in the field, proceed as follows:



## Insert plug-in cards

**WARNING!** Hazard due to supply voltage and DC-voltage from the solar modules. Only qualified electrical professionals are authorized to open the connection area and only when the inverter is not under voltage.

- Set the AC and DC disconnect to the OFF position
- open connection area - see section titled "Connection"

**NOTE!** The COM Card should be inserted in the slot named "ENS".

**Important!** In dealing with plug-in cards observe the general ESD regulations

- Insert card (2) into one of the slots of the control board.
- Tighten card (2) with fastening screw (1). A small metal plate is provided as a tool with the COM Card.
- Insert a 1/2 or 3/4 in. conduit fitting in the knockout (3) labeled "Dat-Com" and fasten it.

**NOTE!** Only use water tight conduits for the AC, DC and the optional DatCom knockouts.

- Insert DatCom cables (see manual FRONIUS IG DatCom through the DatCom conduit and connect them to the sockets "IN" and "OUT")
- Close the connection area
- Set the AC and DC disconnects to the ON position.

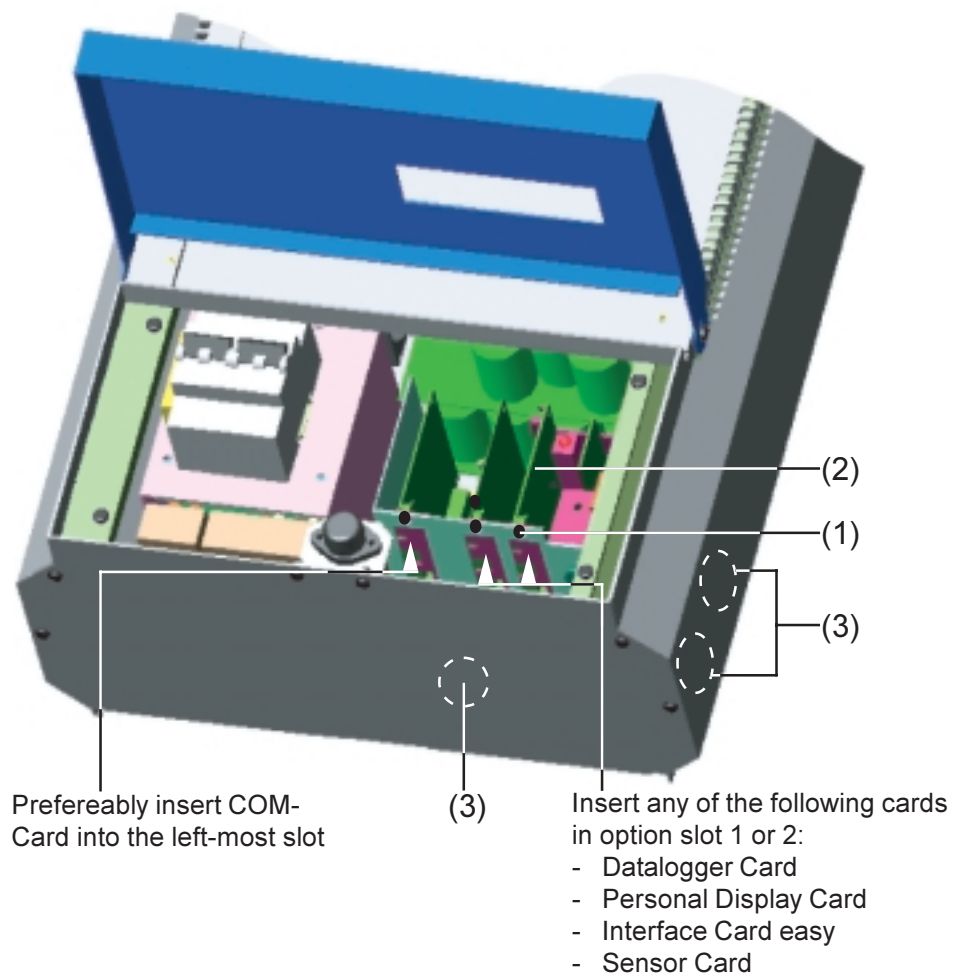

**Configuration** LocalNet automatically identifies different system upgrades (Datalogger Box, Sensor Box, ...). However it is not able to differentiate between several identical system upgrades.

In order to define each FRONIUS IG unit in the LocalNet, the respective unit must have its own individual identification number. For the respective procedure to assign these identification numbers, please consult the chapter "Setup Menu" in your operating instructions.

**Example** Recording and filing of inverter and sensor data by means of Datalogger and Sensor Box.

External communication (LocalNet) takes place via the COM Cards. Each COM Card has two RS-485 interfaces: one for input one for output. Connections are made using RJ45 plugs.

The first FRONIUS IG unit with a COM Card can be located at a distance of up to 3300 ft. (1000 m) from the last FRONIUS IG unit with COM Card.

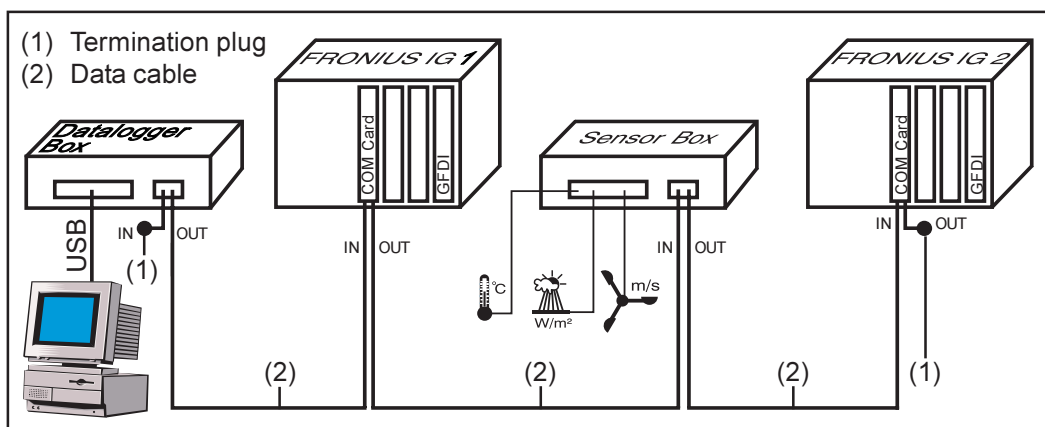

**NOTE!** Each FRONIUS IG that is to supply data must be equipped with a COM Card.

The Datalogger Box has one USB interface for connection to a personal computer and one RS-232 interface for connection to a modem. The Datalogger Card has two RS-232 interfaces for connection to a personal computer and to a modem.

**NOTE!** The order of sequence for placing the sensor boxes, data-logger box, and inverters does not matter.

However:

- Each FRONIUS IG can have only **one** COM Card
- Each network can contain only **one** Datalogger Card or box.
- Each network can contain up to 10 Sensor Cards or boxes.

More information on the various system upgrade possibilities can be found in the respective service manuals or on the internet at [www.fronius-usa.com](http://www.fronius-usa.com).

# Status diagnosis and repair

## Service-Codes Displayed

### Service display

Your FRONIUS IG unit is equipped with a self diagnostic system that automatically identifies a large number of possible operation issues by itself and displays them on the screen. Therefore it is possible to quickly isolate technical issues, and to distinguish between Service Codes related to the installation versus Service Codes which are internal to the inverter.

Whenever the self diagnostic system has identified a particular issue, the respective service code is displayed on the screen.



**NOTE!** Display of a service code for a short time may be the result of the control procedures of your FRONIUS IG unit. If it subsequently continues to operate normally, there has not been a system error.

### Normal operation service codes

As long as the open-circuit voltage of the solar modules is not sufficient, the screen displays the information "DC<sub>LOW</sub>".



As soon as the open-circuit voltage exceeds 150 V, the FRONIUS IG unit starts synchronizing with the grid (display shows "SYNC<sub>AC</sub>").

If the total power output of the solar modules is insufficient, the display shows the message "POWER<sub>LOW</sub>".



After a short time the FRONIUS IG resumes grid synchronization (message: "SYNC<sub>AC</sub>").

## System failure

Should the display remain dark for a longer period of time after sunrise, check the open circuit voltage of the solar modules.

Should the open circuit voltage of the modules (at the terminals within the FRONIUS IG) not reach 170 V, it is possible that there is a problem on the DC side of the photovoltaic system (e.g. wrong module configuration).

If the open circuit voltage of the solar modules (at the terminals of the FRONIUS IG unit) amounts to more than 170 V, there may be an issue with the FRONIUS IG unit. In this case, consult a Fronius trained service technician.

## FRONIUS IG with several power stage sets

A special status diagnostic is run if an error occurs in a FRONIUS IG with several power stage sets. The examples shown below illustrate the trouble-shooting process.

**Important!** It is also possible to call up state messages even if there is no actual error in existence. This form of status polling may be found in the set-up menu.

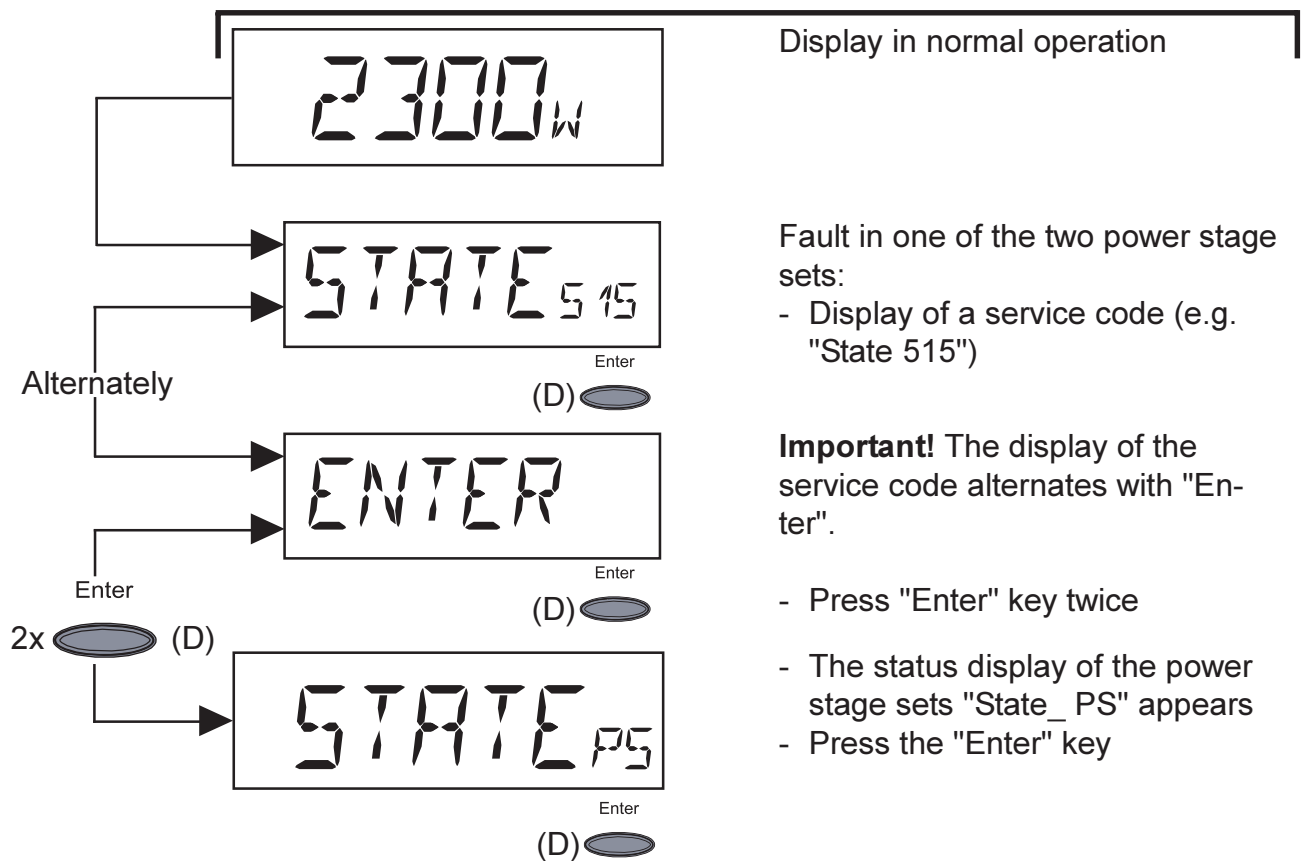

Display in normal operation

Fault in one of the two power stage sets:

- Display of a service code (e.g. "State 515")

**Important!** The display of the service code alternates with "Enter".

- Press "Enter" key twice
- The status display of the power stage sets "State\_PS" appears
- Press the "Enter" key

**Important!** Please see the Section entitled "The Set-Up Menu", "STATE\_PS" for how to proceed.

## Class 1



Definition of service class: First digit in code represents the category.

Service codes of service class 1 are typically temporary. Their cause lies in the grid.

The first reaction of your FRONIUS IG unit is to disconnect from the grid. Subsequently, the grid will be checked for the duration of the observation period stipulated. If after the end of this period no further defect is identified, your FRONIUS IG unit resumes operating and feeding power into the grid.

The following table lists a number of service codes with their respective designation, description, and repair measures.

Code	Designation	Description	Repair
101	Grid voltage not within admissible range	As soon as the grid voltage has returned to admissible range, FRONIUS IG resumes feeding power into the grid	Check grid voltage  If the service code persists you should contact your electrical contractor
104	Grid frequency not within admissible range	As soon as grid frequency has returned to admissible range, FRONIUS IG resumes feeding power into the grid	Check grid frequency  If the service code persists you should contact your electrical contractor
107	No grid voltage detected	As soon as the grid conditions have returned to admissible range, FRONIUS IG resumes feeding power into the grid	Check grid connections and fuses  If the service code does not disappear you should contact your installation specialist
108	Islanding detected	As soon as grid frequency has returned to admissible range, FRONIUS IG resumes feeding power into the grid	Check grid voltage  If the service code does not disappear you should contact your electrical contractor

## Class 2



Definition of service class: First digit in code represents the category.

Service codes of service class 2 are typically temporary. Their cause lies in the grid.

The first reaction of your FRONIUS IG unit is to disconnect from the grid. Subsequently, the grid will be checked for the duration of the observation period stipulated. If after the end of this period no further defect is identified, your FRONIUS IG unit resumes operating and feeding power into the grid.

The following table lists a number of service codes with their respective designation, description, and repair measures.

Code	Designation	Description	Repair
221	Grid voltage (L1/N) exceeds admissible limits	As soon as the grid voltage has returned to admissible range, FRONIUS IG resumes feeding power into the grid	Check grid voltage  If the service code persists you should contact your electrical contractor
222	Grid voltage (L1/N) below admissible limits	As soon as the grid voltage has returned to admissible range, FRONIUS IG resumes feeding power into the grid	Check grid voltage  If the service code persists you should contact your electrical contractor
223	Grid voltage (L2/N) exceeds admissible limits	As soon as the grid voltage has returned to admissible range, FRONIUS IG resumes feeding power into the grid	Check grid voltage  If the service code persists you should contact your electrical contractor
224	Grid voltage (L2/N) below admissible limits	As soon as the grid voltage has returned to admissible range, FRONIUS IG resumes feeding power into the grid	Check grid voltage  If the service code persists you should contact your electrical contractor
225	No grid voltage detected	As soon as the grid conditions have returned to admissible range, FRONIUS IG resumes feeding power into the grid	Check grid connections and fuses  If the service code does not disappear you should contact your installation specialist

### Class 3



Service class 3 comprises service codes that may appear during operation of feeding power supply, that do not cause a permanent interruption of the operation of feeding power into the grid. After automatic disconnection from the grid and waiting for its conditions to return to those stipulated, your FRONIUS IG unit will try to resume feed-in operation.

Code	Designation	Description	Repair
301	Over-current (AC)	Short interruption of power feeding into the grid, caused by overcurrent FRONIUS IG resumes starting up phase	automatically by itself  Should the service code persist, you should contact your electrical contractor
302	Over-current (DC)	Short interruption of power feeding into the grid, caused by overcurrent FRONIUS IG resumes starting up phase	automatically by itself  Should the service code persist, you should contact your electrical contractor
303 *	Over-temperature AC side	Short interruption of power feeding into the grid caused by overtemperature  air vents clogged	after a two minutes' cooling phase your FRONIUS IG unit restarts  clean air vents.  Should the service code persist, you should contact your electrical contractor
304 *	Over-temperature DC-side	Short interruption of power feeding into the grid caused by overtemperature  air vents clogged	after a two minutes' cooling phase your FRONIUS IG unit begins starting up again  clean air vents.  Should the service code persist, you should contact your electrical contractor
306	POWER LOW	Intermediate circuit voltage has dropped below permissible threshold value for feed in	Happens every morning: No action required  Should the service code persist, you should contact your electrical contractor
307	DC LOW	DC-input voltage is too low for feed in	Happens every morning: No action required  Should the service code persist, you should contact your electrical contractor

\* Service code 303 and 304 are shown briefly under certain circumstances. A brief display of the service codes 303 and 304 does not mean there is a fault.

## Class 4



Class 4 service codes may require the intervention of a trained Fronius service technician.

Code	Designation	Description	Repair
401	No internal communication with power stage	If it is possible, your FRONIUS IG unit will resume the power feeding operation after successfully completing another attempt to connect	If service code persists, you should contact a Fronius trained service technician
402	Faulty EEPROM access	If it is possible, your FRONIUS IG unit will resume the power feeding operation after successfully completing another attempt to connect	If service code persists, you should contact a Fronius trained service technician
403	EEPROM faulty	If it is possible, your FRONIUS IG unit will resume the power feeding operation after successfully completing another attempt to connect	If service code persists, you should contact a Fronius trained service technician
406	AC temperature sensor faulty	FRONIUS IG disconnects from the grid for safety reasons	If service code persists, you should contact a Fronius trained service technician
407	DC temperature sensor faulty	FRONIUS IG disconnects from the grid for safety reasons	If service code persists, you should contact a Fronius trained service technician
408	DC injection detected	FRONIUS IG disconnects from the grid for safety reasons	If service code persists, you should contact a Fronius trained service technician
409	No +15V supply available for the control electronics	FRONIUS IG does not connect to the grid	If service code persists, you should contact a Fronius trained service technician
410	Service plug was not inserted in its original position	2-pole plug inserted in the wrong socket.	If service code persists, you should contact a Fronius trained service technician
412	The setting "fixed voltage" has been selected instead of the MPP-voltage operation and the voltage is set to too low a value, or DC voltage exceeds allowable limits.	Fixed voltage lower than the current MPP-voltage	If service code persists, you should contact a Fronius trained service technician, or remove excess modules so DC voltage fits within inverter limits.
413	Control problems	The FRONIUS IG briefly disconnects from the mains, if AC voltage or frequency are out of range	If service code persists, you should contact a Fronius trained service technician



**Class 4**  
(continued)

<b>Code</b>	<b>Designation</b>	<b>Description</b>	<b>Repair</b>
414	EEPROM faulty	Memory deleted	If service code persists, you should contact a Fronius trained service technician
416	Communication with IG-Ctrl not possible	Orange LED lights up, then the FRONIUS IG attempts to restart	If service code persists, contact a Fronius-trained service technician
417	Two power supplies have the same Print Number	FRONIUS IG indicates a critical error	If service code persists, contact a Fronius-trained service technician
419	Two or more power supplies recognized with the identical software serial number	FRONIUS IG indicates a critical error	If service code persists, contact a Fronius-trained service technician
421	Print Number set incorrectly	FRONIUS IG indicates a critical error	If service code persists, contact a Fronius-trained service technician
425	No communication possible with the power supply.	Orange LED lights up, then the FRONIUS IG attempts to restart	If service code persists, contact a Fronius-trained service technician
434	Ground fault detected	Inverter is blocked from feeding energy into the grid	Change GFDI fuse as described in the chapter "Connection"
446	Internal communication error with ground fault detector and interrupter (GFDI)	If it is possible, your FRONIUS IG unit will resume the power feeding operation after successfully completing another attempt to connect	If service code persists, contact your electrical contractor
447	GFDI2 stopped grid monitoring	If it is possible, your FRONIUS IG unit will resume the power feeding operation after successfully completing another attempt to connect	If service code persists, contact your electrical contractor
448	N (neutral) conductor not connected	FRONIUS IG disconnects from grid for safety reasons	Check grid connections and fuses Check jumper setting on GFDI2 board If the service code does not disappear you should contact your installation specialist

## Class 5



Class 5 service codes generally do not impair the operation of feeding power into the grid. They will be displayed until the service code is acknowledged by pressing a key (the FRONIUS IG unit, however, continues working normally in the background).

- press any key
- error message disappears

Code	Designation	Description	Repair
501	defective fan air vents clogged	Low power generation because the temperature in the unit is too high	contact your electrical contractor clean air vents
504	No LocalNet communication possible	FRONIUS IG address issued twice The LocalNet components required are in the FRONIUS IG unit: still, communication is not currently possible	change FRONIUS IG address (chapter: "Setup Menu") Status message goes out after the FRONIUS IG address is altered.
505	EEPROM faulty	Data from the Setup menu is lost	Automatic rectification
506	EEPROM faulty	Data from the "Total" menu is lost	Automatic rectification
507	EEPROM faulty	Data from the menu "Day" / "Year" is lost	Automatic rectification
508	FRONIUS IG address is faulty	Address for data communication is no longer saved	Set address again
509	24h no feed	e.g. solar module covered in snow	e.g. remove snow from solar module
510	EEPROM faulty	SMS settings were restored to standard	If necessary, reconfigure SMS
511	EEPROM faulty	Sensor card settings were restored to standard	If necessary, reconfigure metering channels
512	Too many power supplies in the system	Too many power supplies recognized in the system	If Service-Code persists, contact a Fronius-trained service technician
514	No communication with one of the power stage sets	Warning message from one of the power stage sets, second power stage set working normally	Contact Fronius-trained service technician if service code is displayed permanently
515	Faulty plug-in connections	Temperature sensor DC/AC or DC/DC faulty, service jumper located on "Service" plug-in station or "+15 V secondary" not connected	Check plug-in connections

**Class 5**  
(continued)

516	Status message present for one of the power stage sets	It is not possible to activate all power stage sets	Carry out analysis. Please see section entitled „The Setup Menu“ and „State_PS“ for further details. Contact a Fronius-trained service technician if the service code persists
517	Change of master has taken place	Transformer not connected / not plugged in <hr/> Bridge short-circuit <hr/> Detection of intermediate circuit voltage damaged	Check possible errors referred to in "Description". If service code is displayed permanently: contact Fronius-trained technician.

**Customer service**

**Important!** Contact your Fronius dealer or Fronius trained service partner if an error not mentioned in this table appears.

# Annex

## Technical Data

### General

Input data	IG 2000	IG 3000	IG 2500-LV
Recommended PV power	1500-2500 Wp	2000-3300 Wp	1800-3000 Wp
MPP-voltage range	150 - 400 V		
Max. input voltage (at 1000 W/m <sup>2</sup> / 14 °F in open circuit operation)	500 V		
Nominal input voltage	280 V		
Nominal input current	7.2 A	10.0 A	8.6 A
Maximum usable input current	13.6 A	18 A	16.9 A
Max. array short circuit current	25 A	25 A	25 A
Output data	IG 2000	IG 3000	IG 2500-LV
Nominal output power (P <sub>nom</sub> )	1.8 kW	2.5 kW *	2.15 kW *
P <sub>nom</sub> at +122 °F (50 °C)	1.8 kW	2.0 kW	2.0 kW
Maximum continuous output power	2.0 kW	2.7 kW	2.35 kW
Nominal AC output voltage	240 V	240 V	208 V
Operating AC voltage range default	212 - 264 V	212 - 264 V	183 - 229 V
Adjustment range for voltage	180 - 270 V	180 - 270 V	180 - 240 V
Voltage trip limit accuracy	+/- 1.5 %		
Nominal output current	7.5 A	10.4 A	10.4 A
Maximum output current	8.35 A	11.25 A	11.25 A
Maximum continuous utility backfeed current **	0 A		
Synchronization in-rush current **	0 A		
Maximum output fault current / duration	8.35 A <sub>RMS</sub> 60 ms	11.25 A <sub>RMS</sub> 60 ms	11.25 A <sub>RMS</sub> 60 ms
Maximum output overcurrent protection	20 A		
Nominal output frequency	60 Hz		
Operating frequency range	59.3 - 60.5 Hz		
Adjustment range for frequency	57.0 - 60.5 Hz		
Frequency trip limit accuracy	+/- 0.02 Hz		
Total harmonic distortion	< 5 %		
Power factor	1		

\* Valid to 104 °F (40 °C) when DC operating voltage is above 200 V

\*\* assured by electrical design of the inverter.

**General**  
(continued)

<b>General data</b>	<b>IG 2000</b>	<b>IG 3000</b>	<b>IG 2500-LV</b>
Maximum efficiency	95.2 %	95.2 %	94.4 %
Consumption in standby (night)	< 0.15 W		
Consumption during operation	7 W		
Cooling	controlled forced ventilation		
Protection type	NEMA 3R		
Size l x w x h	18.5 x 16.33 x 8.71 in. (470 x 418 x 223 mm)		
Weight	26 lb. / 11.8 kg		
Admissible ambient temperature	-4 to +122 °F (-20 to 50 °C)		

<b>Protection devices</b>	<b>IG 2000</b>	<b>IG 3000</b>	<b>IG 2500-LV</b>
Ground fault protection	internal GFDI, in accordance with UL 1741 and NEC Art. 690		
DC reverse polarity protection	internal diode		
Islanding protection	internal; in accordance with UL 1741, IEEE 1547 and NEC		
Over temperature	active cooling / output power derating		

**Field adjustable trip points**

<b>Field adjustable trip points</b>	<b>IG 2000</b>	<b>IG 3000</b>	<b>IG 2500-LV</b>
Nominal AC output voltage (L1-L2)	240 V	240 V	208 V
Operating AC voltage range default (L1-L2)	212 - 264 V	212 - 264 V	183 - 229 V
Adjustment range for voltage (L1-L2)	180 - 270 V	180 - 270 V	180 - 240 V
Voltage trip limit accuracy (L1-L2)	+/- 1.5 %		
Nominal output frequency	60 Hz		
Operating frequency range	59.3 - 60.5 Hz		
Adjustment range for frequency	57.0 - 60.5 Hz		
Frequency trip limit accuracy	+/- 0.02 Hz		
Reconnect time	305 s		
Adjustment range for reconnect time	001 - 999 s		
Operating AC voltage range (L-N)	106 - 132 V		
Adjustment range for voltage (L-N)	60 - 144 V		
Voltage trip limit accuracy (L-N)	+/- 1.5 %		

## General

<b>Input data</b>	<b>IG 4000</b>	<b>IG 5100</b>	<b>IG 4500-LV</b>
Recommended PV power	3000-5400 Wp	4000-6300 Wp	3600-5500 Wp
MPP-voltage range	150 - 400 V		
Max. input voltage (at 1000 W/m <sup>2</sup> / 14 °F in open circuit operation)	500 V		
Nominal input voltage	280 V		
Nominal input current	16.3 A	20.8 A	18.3 A
Maximum usable input current	26.1 A	33.2 A	29.3 A
Maximum array short circuit	40 A	40 A	40 A
<b>Output data</b>	<b>IG 4000</b>	<b>IG 5100</b>	<b>IG 4500-LV</b>
Nominal output power (P <sub>nom</sub> )	4.0 kW	5.1 kW *	4.5 kW *
P <sub>nom</sub> at +122 °F (50 °C)	4.0 kW	4.2 kW	4.2 kW
Maximum continuous output power	4.0 kW	5.1 kW	4.5 kW
Nominal AC output voltage	240 V	240 V	208 V
Operating AC voltage range default	212 - 264 V	212 - 264 V	183 - 229 V
Adjustment range for voltage	180 - 270 V	180 - 270 V	180 - 240 V
Voltage trip limit accuracy	+/- 1.5 %		
Nominal output current	16.7 A	21.3 A	21.6 A
Maximum continuous output current	16.7 A	21.3 A	21.6 A
Maximum utility backfeed current **	0 A		
Synchronization in-rush current **	0 A		
Maximum output fault current / duration	16.7 A <sub>RMS</sub> 60 ms	21.3 A <sub>RMS</sub> 60 ms	21.6 A <sub>RMS</sub> 60 ms
Maximum output overcurrent protection	30 A		
Nominal output frequency	60 Hz		
Operating frequency range	59.3 - 60.5 Hz		
Adjustment range for frequency	57.0 - 60.5 Hz		
Frequency trip limit accuracy	+/- 0.02 Hz		
Total harmonic distortion	< 5 %		
Power factor	1		
<b>General data</b>	<b>IG 4000</b>	<b>IG 5100</b>	<b>IG 4500-LV</b>
Maximum efficiency	95.2 %	95.2 %	94.4 %
Consumption in standby (night)	< 0.15 W		
Consumption during operation	15 W		
Cooling	controlled forced ventilation		
Protection type	NEMA 3R		
Size l x w x h	28.34 x 16.46 x 8.78 in. (720 x 418 x 223 mm)		
Weight	41.8 lb. / 19 kg		
Admissible ambient temperature	-4 to +122 °F (-20 to 50 °C)		

\* Valid to 104 °F (40 °C) when DC operating voltage is above 200 V

\*\* assured by electrical design of the inverter.

**General**  
(continued)

Protection devices	IG 4000	IG 5100	IG 4500-LV
Ground fault protection	internal GFDI, in accordance with UL 1741 and NEC Art. 690		
DC reverse polarity protection	internal diode		
Islanding protection	internal; in accordance with UL 1741, IEEE 1547 and NEC		
Over temperature	active cooling / output power derating		

**Field adjustable trip points**

Field adjustable trip points	IG 4000	IG 5100	IG 4500-LV
Nominal AC output voltage (L1-L2)	240 V	240 V	208 V
Operating AC voltage range default (L1-L2)	212 - 264 V	212 - 264 V	183 - 229 V
Adjustment range for voltage (L1-L2)	180 - 270 V	180 - 270 V	180 - 240 V
Voltage trip limit accuracy (L1-L2)	+/- 1.5 %		
Nominal output frequency	60 Hz		
Operating frequency range	59.3 - 60.5 Hz		
Adjustment range for frequency	57.0 - 60.5 Hz		
Frequency trip limit accuracy	+/- 0.02 Hz		
Reconnect time	305 s		
Adjustment range for reconnect time	001 - 999 s		
Operating AC voltage range (L-N)	106 - 132 V		
Adjustment range for voltage (L-N)	60 - 144 V		
Voltage trip limit accuracy (L-N)	+/- 1.5 %		

**Our product complies with the following standards and regulations:**

The FRONIUS IG unit complies with the regulations for "Inverters, converters, and controllers for use in independent power systems" (UL 1741-2005).

In particular, the following standards and regulations are complied with:

- UL 1741-2005 (safety)
- FCC Part 15, Class A & B, regulations (EMI)
- UL 1741-2005, IEEE 1547 & IEEE 1547.1 (Anti-islanding protection)
- NEC Art.690, UL 1741-2005 (Ground-fault detector and interrupter)
- ANSI/IEEE C62.41 (surge test in low voltage AC-Power circuits)

Because the FRONIUS IG follows these regulations and holds these certifications, it should meet or exceed all requirements of inverters from both code and utility officials (for conformity declaration documents see the Annex).

# FRONIUS USA limited 10-Year Warranty

## **FRONIUS IG Solar Inverter Models: FRO- NIUS IG 2000 / 3000 / 2500 LV / 4000 / 5100 / 4500-LV**

At Fronius, we have been designing and manufacturing high quality power electronics equipment for over 60 years. And all our production facilities are ISO 9001 certified.

You will probably not encounter any service-related issues with your FRONIUS IG Solar Inverter. However, in the unlikely event that within Ten (10) years from the original purchase you discover a problem caused by defects in either workmanship or materials, we will see that it is either repaired or replaced. Repair or replacement depends on Fronius' evaluation of the issue and what we decide makes the most sense according to the situation. The warranty is based on the inverter's serial number, allowing the warranty to be transferred to another owner if the FRONIUS IG Solar Inverter remains installed in the original installation location. Because the warranty is tied to the serial number, there is no paperwork to transfer the warranty to a new owner.

The FRONIUS IG Solar Inverters are designed to withstand normal operating conditions and typical wear and tear when the FRONIUS IG Solar Inverter is used for its original intent, in compliance with the FRONIUS IG Installation and Operational Manual(s) supplied with the original equipment. This warranty does not cover damages by improper installation or operation, misuse, abuse, manipulation, alterations or repair attempts, accidents, fire, floods, acts of God, and incidental or consequential damage caused by defects with other components of the solar system. This warranty does not extend beyond the original cost of the FRONIUS IG Solar Inverter.

## **Policy and procedure for warranty re- turns and repairs**

To obtain service you must follow this policy and procedure for warranty returns and repairs:

- All returned FRONIUS IG Solar Inverters require a Returned Merchandise Authorization Number (RMA)
- A request for a RMA number requires the following information:
  - Proof-of-purchase in the form of the original invoice
  - Model Number of the FRONIUS IG Solar Inverter
  - Serial Number of the FRONIUS IG Solar Inverter
  - Description of the problem
  - Shipping address for the repaired or replaced equipment
- All FRONIUS IG Solar Inverters authorized for return by FRONIUS USA must be returned in their original shipping container or packaging providing equal protection
- Shipping costs to FRONIUS USA and back to the purchaser of repaired or replacement FRONIUS IG Solar Inverters is the responsibility of FRONIUS USA



**Policy and procedure for warranty returns and repairs**  
(continued)

- The warranty period of any repaired or replacement inverter is 12 months after shipment from FRONIUS USA or the original warranty period which ever is later
- Labor costs related to uninstalling the defective equipment and re-installing the repaired or replacement equipment are not covered under the warranty.

Some states do not allow the exclusion or limitation of incidental or consequential damages. This warranty gives you specific legal rights, and you may also have other rights, which vary from state to state.

FRONIUS USA LLC General Terms and Conditions apply.

Contact your local dealer or FRONIUS Service Partner for immediate handling of warranty issues. For service assistance to resolve a FRONIUS IG solar inverter problem, or for product information please contact:

FRONIUS USA LLC - Solar Electronics Division  
10421 Citation Drive, Suite 1100, Brighton, MI 48116  
E-Mail: [pv-us@fronius.com](mailto:pv-us@fronius.com)  
<http://www.fronius-usa.com>

## **Disposal of obsolete equipment**

**Recycling**

Should your inverter be replaced at some future date, Fronius will accept the obsolete equipment back and provide for its proper recycling.



# Certificate of Compliance

**Certificate:** 1878274 **Master Contract:** 203213  
**Project:** 2020258 **Date Issued:** 2008/03/12  
**Issued to:** **Fronius International GmbH**  
Guenter Fronius Strasse 1  
Wels-Thalheim, 4600  
Austria  
Attention: Mr. Lehner Christian

*The products listed below are eligible to bear the CSA Mark shown with adjacent indicators 'C' and 'US'*



**Issued by:** Ernesto Lopez, AScT.

**Authorized by:** Lindsay Clark, Product Group Manager

A handwritten signature in black ink, likely of Lindsay Clark, the Product Group Manager.

## **PRODUCTS**

**CLASS 5311 09** - POWER SUPPLIES - Distributed Generation Power Systems Equipment  
**CLASS 5311 89** - POWER SUPPLIES - Distributed Generation - Power Systems Equipment  
- Certified to U.S. Standards

## **PART A:**

Utility Interactive Inverter, Models IG 2000 NEG, IG 2000 POS, IG 3000 NEG, IG 3000 POS, IG 2500-LV NEG, and IG 2500-LV POS, permanently connected. The following system ratings are for Models IG 2000, IG 3000 and IG 2500-LV, unless otherwise indicated:

## **INPUT RATINGS:**

The 'C' and 'US' indicators adjacent to the CSA Mark signify that the product has been evaluated to the applicable CSA and ANSI/UL Standards, for use in Canada and the U.S., respectively. This 'US' indicator includes products eligible to bear the 'NRTL' indicator. NRTL, i.e. National Recognized Testing Laboratory, is a designation granted by the U.S. Occupational Safety and Health Administration (OSHA) to laboratories which have been recognized to perform certification to U.S. Standards.



**Certificate:** 1878274

**Master Contract:** 203213

**Project:** 2020258

**Date Issued:** 2008/03/12

---

Maximum input voltage: 500 V

Range of input operating voltage: 150-450 V

Maximum input current (ac or dc): 13.6 A (IG 2000), 18.0 A (IG 3000), 16.9 A (IG 2500-LV)

Maximum input short circuit current: 25.0 A

Maximum input source backfeed current to input source: 0

**OUTPUT RATINGS:**

Output power factor rating: 1

Operating voltage range (ac) (L-L): 212-264 V (IG 2000, IG 3000), 183-229 V (IG 2500-LV)

Operating frequency range or single frequency: 59.3-60.5 Hz

Number of phases: 1

Nominal output voltage (ac): 240 V (IG 2000, IG 3000), 208 V (IG 2500-LV)

Normal output frequency: 60 Hz

Maximum continuous output current (ac): 8.35 A (IG 2000), 11.25 A (IG 3000, IG 2500-LV)

Maximum continuous output power (ac) (@40°C): 1.80 KW (IG 2000), 2.50 KW (IG 3000), 2.15 KW (IG 2500-LV)

Maximum continuous output power (ac) (@50°C): 1.80 KW (IG 2000), 2.00 KW (IG 3000, IG 2500-LV)

Maximum output overcurrent protection: 20 A

Utility interconnection voltage and frequency trip limits and trip times: See Note 1 below.

Trip limit and trip time accuracy - Voltage: +/- 1.5 %; Frequency: +/- 0.02 Hz

Normal operation temperature range: -20°C - +50°C

Output power temperature derating and maximum full power operating ambient: See Maximum Continuous Output Power

Enclosure Rating Type: 3R

Notes:



Certificate: 1878274

Master Contract: 203213

Project: 2020258

Date Issued: 2008/03/12

1. Utility Interconnection Default Voltage and Frequency Trip Limits and Trip Times: Voltage and frequency limits for utility Interaction.

Simulated utility source - Voltage (V): Condition (A)  $< 0.50 V_{nor}$ ; (B)  $0.50 V_{nor} \leq V < 0.88 V_{nor}$ ; (C)  $1.10 V_{nor} < V < 1.20 V_{nor}$ ; (D)  $1.20 V_{nor} \leq V$ ; (E) Rated; (F) Rated; (G) Rated

Simulated utility source - Frequency (Hz): Condition (A) Rated; (B) Rated; (C) Rated; (D) Rated; (E)  $f > 60.5$ ; (F)  $f < (59.8 - 57.0)$  (Adjustable Set Point); (G)  $f < 57.0$

Maximum time (sec) at 60 Hz before cessation of current to the simulated utility:  
Condition (A) 0.16; (B) 2; (C) 1; (D) 0.16; (E) 0.16; (F) 0.16; (G) 0.16

2. Utility interactive evaluations were conducted with the following firmware:

Device: Software Version

Main Controller Microprocessor: 2.09.00

Power Board (DSP): 2.03.01

GFDI Board: 1.00.00

#### PART B:

Utility Interactive Inverter, Models IG 4000 NEG, IG 4000 POS, IG 5100 NEG, IG 5100 POS, IG 4500-LV NEG, and IG 4500-LV POS, permanently connected. The following system ratings are for Models IG 4000, IG 5100 and IG 4500-LV, unless otherwise indicated:

#### INPUT RATINGS:

Maximum input voltage: 500 V

Range of input operating voltage: 150-450 V

Maximum input current (ac or dc): 26.1 A (IG 4000), 33.2 A (IG 5100), 29.3 A (IG 4500-LV)

Maximum input short circuit current: 40.0 A

Maximum input source backfeed current to input source: 0

#### OUTPUT RATINGS:



**Certificate:** 1878274

**Master Contract:** 203213

**Project:** 2020258

**Date Issued:** 2008/03/12

---

Output power factor rating: 1

Operating voltage range (ac) (L-L): 212-264 V (IG 4000, IG 5100), 183-229 V (IG 4500-LV)

Operating frequency range or single frequency: 59.3-60.5 Hz

Number of phases: 1

Nominal output voltage (ac): 240 V (IG 4000, IG 5100), 208 V (IG 4500-LV)

Normal output frequency: 60 Hz

Maximum continuous output current (ac): 16.7 A (IG 4000), 21.3 A (IG 5100), 21.6 A (IG 4500-LV)

Maximum continuous output power (ac) (@40°C): 4.00 KW (IG 4000), 5.1 KW (IG 5100), 4.50 KW (IG 4500-LV)

Maximum continuous output power (ac) (@50°C): 4.00 KW (IG 4000), 4.2 KW (IG 5100, IG 4500-LV)

Maximum output overcurrent protection: 30 A

Utility interconnection voltage and frequency trip limits and trip times: See Note 1 below.

Trip limit and trip time accuracy - Voltage: +/- 1.5 %; Frequency: +/- 0.02 Hz

Normal operation temperature range: -20°C - +50°C

Output power temperature derating and maximum full power operating ambient:

Maximum Continuous Output Power (AC) @ 25°C, 150 VDC Input): 2.96 KW

Maximum Continuous Output Power (AC) @ 50°C, 150 VDC Input): 2.94 KW

Maximum Continuous Output Power (AC) @ 25°C, 163 VDC Input): 4.0 KW (IG 4000), 5.1 KW (IG 5100), 4.5 KW (IG 4500-LV)

Maximum Continuous Output Power (AC) @ 40°C, 163 VDC Input): 4.0 KW (IG 4000), 4.71 KW (IG 5100), 4.5 KW (IG 4500-LV)

Maximum Continuous Output Power (AC) @ 50°C, 163 VDC Input): 3.74 KW

Maximum Continuous Output Power (AC) @ 25°C, 450 VDC Input): 4.0 KW (IG 4000), 5.1 KW (IG 5100), 4.5 KW (IG 4500-LV)

Maximum Continuous Output Power (AC) @ 50°C, 450 VDC Input): 3.63 KW

Enclosure Rating Type: 3R



Certificate: 1878274

Master Contract: 203213

Project: 2020258

Date Issued: 2008/03/12

Notes:

1. Utility Interconnection Default Voltage and Frequency Trip Limits and Trip Times: Voltage and frequency limits for utility Interaction

Simulated utility source - Voltage (V): Condition (A)  $< 0.50 V_{nor}$ ; (B)  $0.50 V_{nor} \leq V < 0.88 V_{nor}$ ; (C)  $1.10 V_{nor} < V < 1.20 V_{nor}$ ; (D)  $1.20 V_{nor} \leq V$ ; (E) Rated; (F) Rated; (G) Rated

Simulated utility source - Frequency (Hz): Condition (A) Rated; (B) Rated; (C) Rated; (D) Rated; (E)  $f > 60.5$ ; (F)  $f < (59.8 - 57.0)$  (Adjustable Set Point); (G)  $f < 57.0$

Maximum time (sec) at 60 Hz before cessation of current to the simulated utility:  
Condition (A) 0.16; (B) 2; (C) 1; (D) 0.16; (E) 0.16; (F) 0.16; (G) 0.16

2. Utility interactive evaluations were conducted with the following firmware:

Device: Device Version

Main Controller Microprocessor: 2.09.00

Power Board (DSP): 2.03.01

GFDI Board: 1.00.00

**APPLICABLE REQUIREMENTS**

CAN/CSA-C22.2 No. 0-M91 - General Requirements - Canadian Electrical Code - Part II

CAN/CSA-C22.2 No. 0.4-04 - Bonding of Electrical Equipment

CAN/CSA-C22.2 No. 107.1-01 - General Use Power Supplies

UL Std No. 1741-First Edition - Static Inverters and Charge Controllers for Use in Photovoltaic Power Systems (Including Revisions through and including November 7, 2005)



## Supplement to Certificate of Compliance

Certificate: 1878274

Master Contract: 203213

*The products listed, including the latest revision described below, are eligible to be marked in accordance with the referenced Certificate.*

### Product Certification History

---

Project	Date	Description
2020258	2008/03/12	Update Report to include corrections.
1996777	2008/02/06	Update report to include alternate construction.
1878274	2007/03/30	Utility Interactive Inverters, Models IG 2000 NEG, IG 2000 POS, IG 3000 NEG, IG 3000 POS, IG 2500-LV NEG, IG 2500-LV POS, IG 4000 NEG, IG 4000 POS, IG 5100 NEG, IG 5100 POS, IG 4500-LV NEG, IG 4500-LV POS. (C/US)











# Fronius Worldwide - [www.fronius.com/addresses](http://www.fronius.com/addresses)

**A** Fronius International GmbH  
4600 Wels-Thalheim, Günter-Fronius-Straße 1, Austria  
E-Mail: [pv@fronius.com](mailto:pv@fronius.com)  
<http://www.fronius.com>

**USA** Fronius USA LLC Solar Electronics Division  
10421 Citation Drive, Suite 1100, Brighton, MI 48116  
E-Mail: [pv-us@fronius.com](mailto:pv-us@fronius.com)  
<http://www.fronius-usa.com>

Under <http://www.fronius.com/addresses> you will find all addresses of our sales branches and partner firms!