



FranklinWH System Installation Guide

aPower 2, SKU: APR-10K15V2-US

aGate X, SKU: AGT-R1V2-US

Floor mounting bracket, SKU: ACCY-FMBV2-US

©2025 FranklinWH Energy Storage Inc. All rights reserved.

All information in this Manual is subject to the copyright and other intellectual property rights of FranklinWH Energy Storage Inc. This manual may not be modified, copied or reproduced, in whole or in part, without the prior written permission of FranklinWH Energy Storage Inc.

Please visit [FranklinWH Support](#) for the latest FranklinWH documents.

All brands and trademarks mentioned in this document are the property of their respective owners, and their use in this document does not imply the sponsorship or recognition of their products or services.

Please read this document carefully to ensure the best reliability of the product and your warranty eligibility. For further information about the warranty, please refer to the **FranklinWH Limited Warranty**.

This document is intended for use by professional installation and maintenance service providers only and no statements, information or recommendations in this document constitute any express or implied warranty.



Please read this document carefully before installing or using the FranklinWH equipment. Failure to follow any instructions or warnings in this document may result in damage to the equipment, personal electric shock, severe injury, or even death.

Product Information

The FranklinWH system is composed of aPower, aGate, other electrical components, and the FranklinWH App.

FranklinWH Energy Storage Inc. (FranklinWH) reserves the right to make any improvements to the product, and the contents in this document shall be subject to updates without further notification.

All images and pictures provided in this Manual are only for demonstration purposes and may differ in detail from the product, based on the product version.

FCC Compliance

This equipment has been tested and found to comply with the limits for a Class B digital device, pursuant to part 15 of the FCC Rules. These limits are designed to provide reasonable protection against harmful interference in a residential installation. This equipment generates, uses and can radiate radio frequency energy and, if not installed and used in accordance with the instructions, may cause harmful interference to radio communications. However, there is no guarantee that interference will not occur in a particular installation. If this equipment does cause harmful interference to radio or television reception, which can be determined by turning the equipment off and on, the user is encouraged to try to correct the interference by one or more of the following measures:

- Reorient or relocate the receiving antenna.
- Increase the separation between the equipment and receiver.
- Connect the equipment into an outlet on a circuit different from that to which the receiver is connected.
- Consult the dealer or an experienced radio/TV technician for help.

MPE caution (if an FCC certified RF module is inserted in and the separation distance is indicated in the FCC grant of RF module).

To satisfy FCC / IC RF exposure requirements, a separation distance of 8 in. (20 cm) or more should be maintained between the antenna of this device and persons during device operation.

To ensure compliance, operations at closer than this distance is not recommended.

Feedback

If you have any questions or comments, please send us an email at: service@franklinwh.com

Disposal of Scrapped Products

Scrapped products (including their internal chemicals and electrical materials) should not be disposed of with household waste. Please refer to your local laws and regulations regarding disposal.



CONTENT

Safety Statements	1
Safety Symbols.....	1
Safety Instructions for Operation.....	2
Safety Instructions for Installation Site	5
Fire and Other Emergency Situations.....	7
FranklinWH System Overview.....	8
Whole-Home Backup System.....	8
Partial Backup System.....	9
Installation Preparations	10
Site Planning.....	10
Tools Needed	14
Items Provided by Installers.....	16
Unboxing	17
Unbox the aGate	17
Unbox the aPower	18
Installation	19
aGate Installation.....	19
Remove the aGate Door and Inner Panel.....	19
Prepare aGate Cable Inlets.....	21
Enlarge or Drill New Holes (if necessary)	22
Mount the aGate on a Wall.....	22
Install Optional Module(s).....	24
Install Breakers as Needed.....	24
aPower Installation	26
Wall-Mounted Installation.....	26
Floor-Mounted Installation.....	32
Install a Combiner Box (if needed)	34
System Wiring.....	35







Install Electrical Conduit in the aPower Wiring Compartment.....	35
Communications Wiring.....	38
Electrical Wiring.....	42
Wiring Requirements.....	50
Install an Optional Emergency Power Off (EPO) Switch.....	51
Complete Installation.....	53
Install the aPower Exterior Cover.....	53
Re-Install the aGate Door and Inner Panel.....	56
Commissioning and Acceptance.....	56
Appendix 1: Allowed Breakers.....	57
Appendix 2: Datasheet.....	61

Safety Statements











This Guide includes important information about the FranklinWH system. Please read this Guide carefully before installation, maintenance, or use. Failure to follow any instruction in this Guide may lead to risks of equipment damage, electric shock, severe personal injury and even death, and may also void the warranty ([FranklinWH Support](#)).













The DANGER, WARNING, and NOTE alerts are supplemental to the safety instructions and are not exhaustive.





Safety Symbols

	DANGER: This indicates a hazardous situation, which if not avoided, could result in serious injury or death.
	DANGER: There are fire risks in the battery packs.
	WARNING: This indicates a situation where failure to follow instructions may be a safety hazard or cause equipment malfunction. Use extreme caution and follow instructions.
	NOTE: This indicates information important for optimal system operation. Follow instructions.
	PROTECTIVE GROUNDING TERMINAL: This indicates the position of grounding connection on the equipment.
 5 Minutes	WAIT TIME: It means there are electric shock risks inside the equipment, please wait 5 minutes before proceeding.
	ELECTRONIC DEVICE: DO NOT THROW AWAY. Scrapped electronic products and batteries cannot be disposed of together with household wastes. Please consult your local laws and regulations for further information.











Safety Instructions for Operation





	DANGER: The installation, wiring, maintenance, transportation, and handling of each aGate and aPower should follow local laws, regulations and standards, and the Safety Instructions in this Guide serve as supplementation to the laws, regulations, and standards.
	DANGER: Before any electrical operation starts, please turn off the grid power supply switch, generator input switch, the PV input switch, the load switch, and lock the switches. If the switches cannot be locked, please lock the distribution box where the switches are installed. A warning sign, Out of Operation , or Do NOT Turn On , should be hung.
	DANGER: Both aPower and aGate are electrical equipment, and improper operation may lead to electric shock, energy hazards, or chemical hazards. Please do NOT open the cabinet or disassemble without express direction from the FranklinWH service team.
	DANGER: Only FranklinWH certified and qualified technicians can install, maintain, or replace aGate and aPower equipment or wiring. They must wear personal protective equipment (PPE) during operation.
	DANGER: It is strictly forbidden to work on or operate the system alone. For safety, make sure that there is someone around you who can help.
	DANGER: It is strictly forbidden to install, maintain, or handle the system outdoors during bad weather conditions, such as lightning, thunder, rain, snow, or strong winds.
	DANGER: In case of a battery fire, please take action as instructed in the Safety Data Sheet .
	DANGER: The aPower must be carefully handled and installed using lifting equipment to avoid injury to installers or the aPower.
	DANGER: During the transport and handling of aGate and aPower units, extreme care is required to avoid dropping, bumping, stomping, or inverting the equipment. To prevent potential damage, please keep all aPower units in their packaging until ready to install.
	DANGER: During use, storage, and transport, ensure that the ambient temperature of an aPower does not exceed 122° F (50° C), that it is not near flammable items, and that the cooling system and vents are not blocked.
	DANGER: Do not attempt to take apart, repair and/or modify an aGate or aPower without the authorization of FranklinWH. And it is prohibited to open the battery pack chamber in any situation. Otherwise, it may lead to safety hazards and void your warranty.

	DANGER: To prevent misoperation, ensure that the upstream and downstream switches are disconnected and padlocked during installation or maintenance.
	DANGER: If an aPower or aGate is found damaged (except for minor defects in exterior painting) after it is unboxed or malfunctioning on installation, please do NOT operate it and contact your after-sales service provider for support.
	DANGER: Before any installation and commissioning of an aPower, please keep the round switch button on the right part of aPower off (extended, flush with the case) and prevent the ON/OFF switch from being operated by mistake.
	DANGER: If the aPower battery is leaking electrolyte, smoking, or catching fire, if it is safe to do so, disconnect the AC power from the FranklinWH system, and turn off the aPower switch to stop charging and discharging the battery.
	DANGER: The installation of the FranklinWH system must comply with all applicable requirements of NFPA855.
	DANGER: Both electric connection and electric isolation need to comply with the local standards and National Electric Codes (NEC), ANSI/NFPA 70 or Canadian Standards Association CSA C22.1.
	DANGER: The installer needs to provide suitable conduits and cables, and complete the installation process in accordance with the local regulations and UL514B.
	WARNING: For maintenance purposes, do NOT use any parts or fittings that are not listed in this Guide or that are purchased from any source other than FranklinWH or its recognized dealers.
	WARNING: Measures should be taken to prevent foreign objects from entering any aPower or aGate.
	WARNING: Do NOT use paint on any part of an aPower or aGate, whether internal or external, especially on the protective cover except for exterior paint that has been worn out or damaged in the transportation, installation, or maintenance process. The damaged part can be repaired with paint or topcoat of the same color.
	WARNING: Do NOT connect an aPower directly to the PV inverter.
	WARNING: Before installation, do not store an aPower on site for more than one month. After installation, do not turn on the aPower before connecting the PV and grid, otherwise the battery will be depleted due to a long period of time without charging.

	WARNING: The FranklinWH system is composed of one or more aGate controllers, one or more aPower batter units, and other electrical components which may be used separately.
	WARNING: An aPower may only be connected to the aPower breaker on the aGate or to the backup load terminals on aGate.
	WARNING: The inputs from grid and generators may only be connected to the respective reserved terminals on the aGate.
	WARNING: The operation of the FranklinWH system requires an Internet connection. Extended offline operation may result in a voided warranty. Please refer to FranklinWH Support for information.

Safety Instructions for Installation Site

	DANGER: The installation site of aPower and aGate units should be protected from access by children, or additional protective measures should be taken to protect the FranklinWH equipment from misoperation and contact by children.
	DANGER: The installation site of aPower and aGate units should be kept away from heating devices, or any source of heat and/or fire.
	DANGER: The aPower and aGate installation area should be well-ventilated to maintain the ambient temperature within $-4^{\circ}\text{F} \sim 122^{\circ}\text{F}$ ($-20^{\circ}\text{C} \sim 50^{\circ}\text{C}$) and the relative humidity between 5 % and 95 %. The altitude should be lower than 9,843 ft (3,000 m). If an aPower or an aGate is to be installed in a confined area, forced ventilation must be in place.
	DANGER: The aPower and aGate installation area should be protected from flooding and standing water.
	DANGER: The aPower and aGate installation area should be away from flammable and explosive materials.
	DANGER: The installation site for aPower should have a fire detection and protection system that meets the local building and fire codes. Temperature detectors and fire detectors must be used in the vicinity of the installation zone and must be connected to the family fire control system.
	WARNING: Before the installation starts, engineers should check and locate the embedded electric wires and water pipes to avoid potential property damage and personal injury during the installation process.
	WARNING: aPower units may be installed on the floor or on walls; floor installation is recommended. If wall-mounted, the wall should be able to provide sufficient bearing capacity.
	WARNING: The aPower and aGate installation area should be protected from dust and smoke.
	WARNING: The aPower and aGate installation site should be protected from direct exposure to sunshine, rain, and snow.
	WARNING: The aPower and aGate installation site should have no water source above it or in the vicinity, including water pipes, shower, faucet, and containers of liquids.

	WARNING: The installation site should be properly leveled and hardened if the aPower is floor mounted. If there is grass nearby, a layer of cement or slab stone must be placed on the projection area around the equipment to prevent grass growth and protect the equipment.
	WARNING: Do NOT clean aPower and aGate units with cleaning agents or expose them to flammable or irritant chemicals or their vapors.
	WARNING: The noise factor (< 45 dB) must be considered when selecting the installation site for each aPower. Selection of the site must involve consent of residents.
	WARNING: It is required that either Ethernet or Wifi connectivity is provided at the aGate installation site. Ethernet and Wifi connections are more reliable, but 4G connection are also possible, though not suggested as the primary method.

Fire and Other Emergency Situations

Fire:

- Shut off the aPower breaker on the aGate, if it is safe to do so.
- Evacuate to a safe area.
- Contact 911 as soon as it is safe to do so.
- Use approved fire extinguishing devices, if it is safe to do so.

Flood:

- Shut off the aPower breaker on the aGate if it is safe to do so.
- If the wiring sections of an aPower or aGate are submerged, please stay away from the water. Electric leakage may result in electric shock.
- Drain the water to protect the system if it is safe and possible.
- If water rises to the battery level, please call your installer for inspection. If the water level is below the battery chamber, please allow the site to completely dry.

Abnormal noise, odor, or smoke:

- Shut off the aPower breaker on the aGate, if it is safe to do so.
- Check and ensure your aPower is well ventilated and the vents are not blocked.
- Keep the installation site well ventilated.
- Call your after-sales service for support.

FranklinWH System Overview

FranklinWH is a whole-home energy solution suitable for residential use. The two key components are the aGate, an intelligent power management unit for whole home power control, and the aPower, an energy storage battery unit with a built-in battery management system (BMS) and an inverter. Homeowners can monitor and operate their systems remotely via the FranklinWH App. With AC coupling and energy management technologies, the FranklinWH system provides a reliable household backup and load control solution for homes.

The system backup options include whole-home and partial backup. Load selection for the options must be completed during the system design phase.

The aPower stores energy from the grid, PV systems, and generators, and can power the home during grid outages, during peak rate periods, or at night (for PV self-generation).

Whole-Home Backup System

In the whole-home backup system, all household loads, except for those on Smart Circuits, are connected via the Main Panel to the backup port of the aGate. If the grid fails, the FranklinWH system will power all household energy loads.

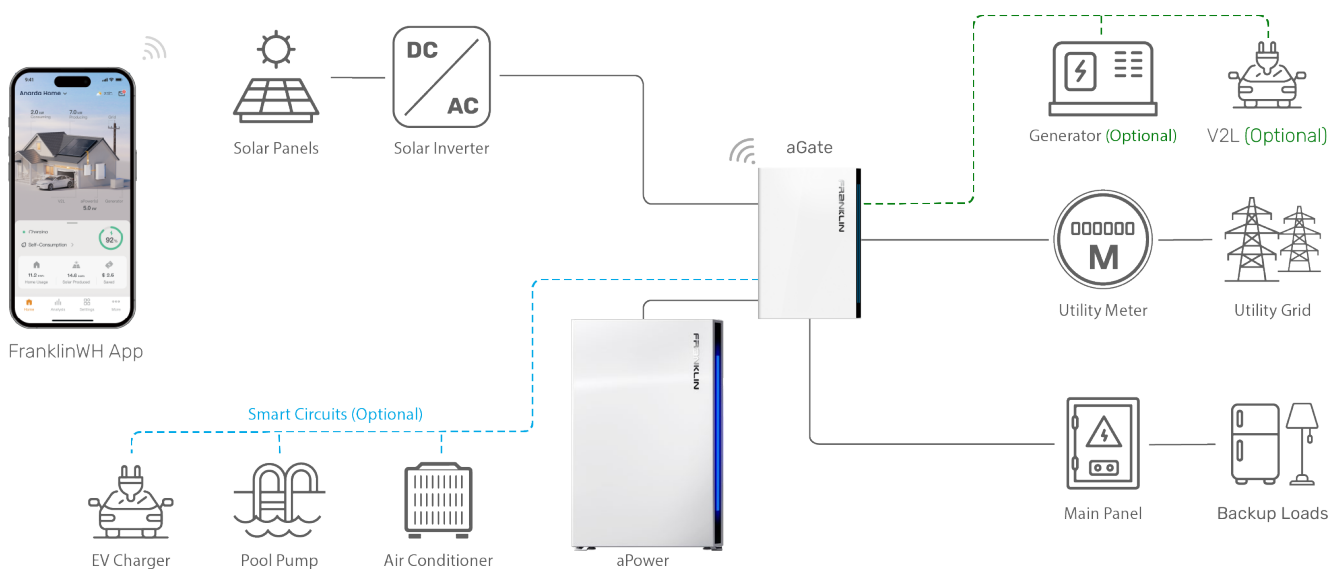

Partial Backup System

If you select a partial backup configuration, you need to identify backup loads during system configuration. Connect the backup loads (except for Smart Circuit loads) to the aGate backup port and connect the non-backup loads to the aGate non-backup port. If the grid fails, the system will only power the backup loads during an outage.

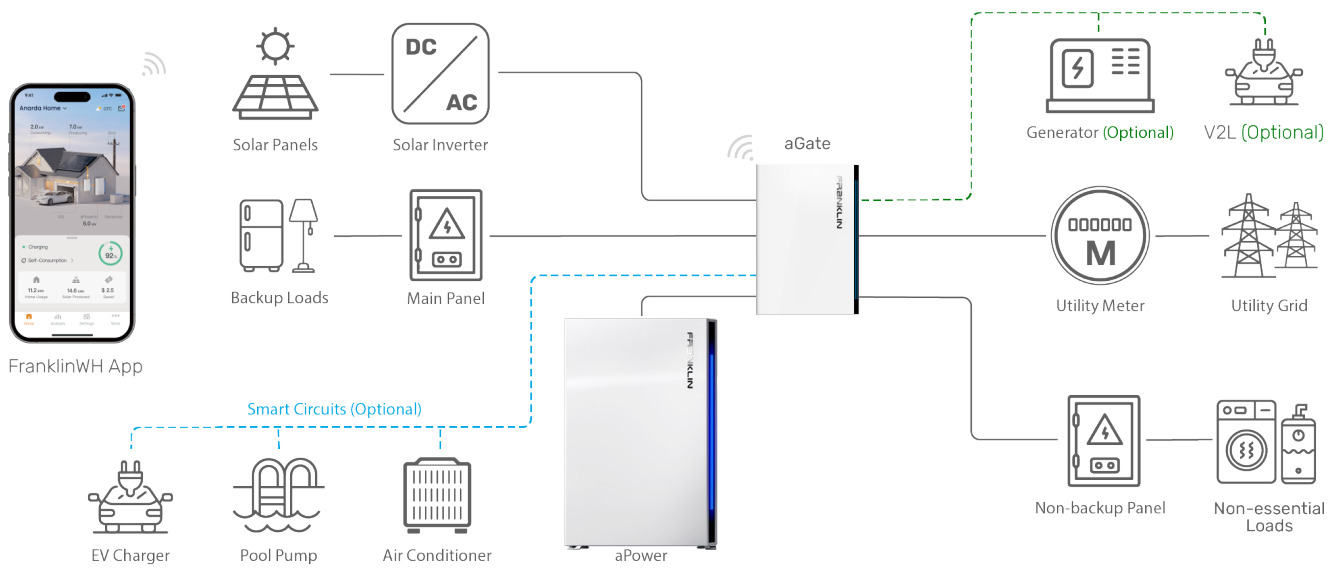

Installation Preparations

Site Planning

1. Plan installation position

NOTE



The installation location must avoid water and power conduits. Refer to all applicable local codes and standards.

In Canada, it's highly recommended to install the system indoors to maintain the specified operational temperatures.

- a) Choose a mounting location that can bear the weight of the aGate, aPower and bracket.
- b) The details below are general guidelines for spacing and may not be applicable. Please consult with your local AHJ or Utility before finalizing the spacing.

aGate

There should be at least 6 in. (0.15 m) of clearance from the top of aGate to the ceiling, and 36 in. (0.91 m) of clearance in front of the aGate.

The recommended distance between the bottom of aGate and the ground is 48 in. (1.2 m), not exceeding 52 in. (1.3 m). The maximum distance between the power switch button on the aGate and the ground shall not exceed 79 in. (2 m) per the NEC requirements.

aPower

There should be a minimum clearance of 6 in. (0.15 m) from the top of aPower to the ceiling.

For an aPower mounted on a wall, the maximum distance between the bottom of the aPower and the ground shall be ≤ 42 in. (1.1 m) i.e., **the maximum distance between the aPower switch button and the ground shall not exceed 79 in. (2 m) per NEC 404.8(A) requirements.**

For multiple aPowers installed at the same height, the minimum clearance between adjacent aPower units is 4 in. (0.1 m). And the recommended distance from aPower to windows or the side walls is 11 in. (280 mm).

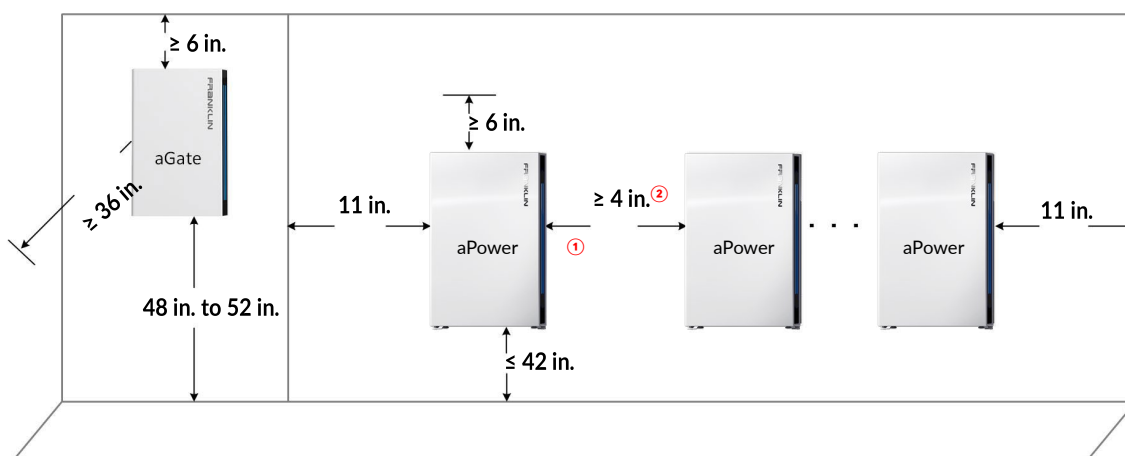

① NEC 408.4(A) requires the aPower switch to be no more than 79 in. (2 m) from the floor.

② 4 in. (0.1 m) between adjacent aPower units is UL9540A required clearance. Refer to all applicable local codes and standards.

- c) The system requires an internet connection. All signal transfers between aPower and aGate units, the generator, and the router are provided by a CAN bus, network cables or other signal transmission cables. Long distances will likely adversely affect the quality and speed of communications, negatively impacting equipment operations. Recommended maximum cable lengths listed below.

Connection	Maximum cable length
aPower to aGate	164 ft (50 m)
Split CT to aGate	49 ft (15 m)

2. Plan the positions of equipment inputs and outputs

- aPower inputs and outputs

The positions of inputs and outputs on an aPower are shown below. The following scenarios offer variations on the cable inlets and outlets of an aPower to accommodate variations in the existing residential wiring layout.

The cable inlets on the wiring compartment of an aPower is 1.67 in. (42.5 mm) in diameter. The pull boxes have thread size of NPT 1-1/4".

Scenario 1: The electrical conduits and aPower share the same side of the wall.

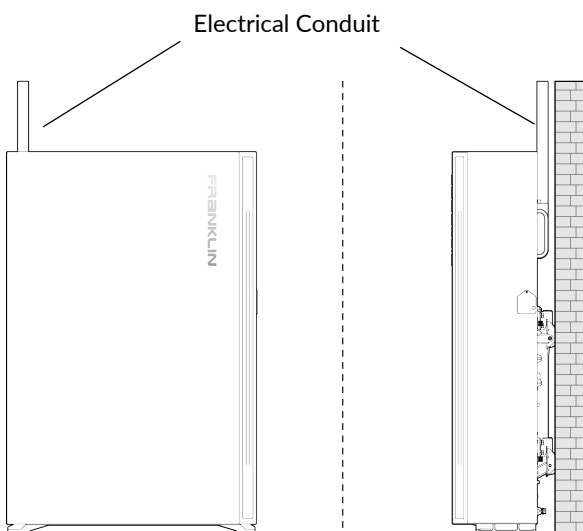

Gasketed pull boxes and sealing rings must be used to ensure the tightness of the wiring compartment.

Scenario 2: The cables will connect to the aPower from inside or through the electrical conduits through the wall.

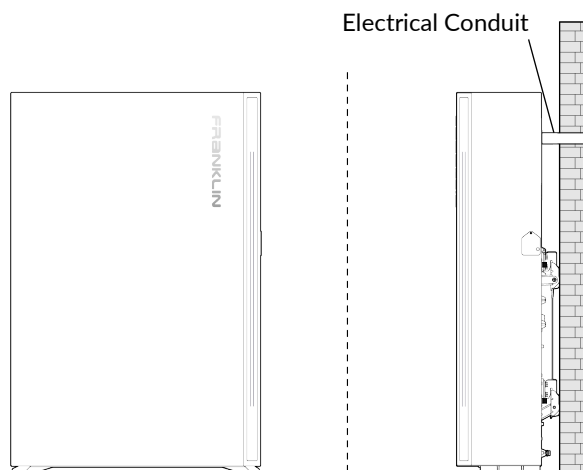

Sealing rings must be used. A good seal must be guaranteed between the electrical conduits and the wiring compartment which can be achieved by using a conduit hub, sealing rings, or caulk.

- aGate inputs and outputs

The positions of inputs and outputs on an aGate are as shown below. The following scenarios offer variations on the cable inlets and outlets of an aGate to accommodate variations in the existing residential wiring layout.

The knockout holes on the left and lower panel of aGate are 1.38 in. (35 mm) in diameter, while the plug hole on the upper panel is 2.49 in. (63 mm) in diameter. If the knockout holes do not match the electrical conduits in hub diameter, additional reducing fittings will be needed to achieve the required IP grade.

WARNING



It is recommended to install cables through the bottom of the aGate.

If a top inlet cable is installed, additional waterproofing measures must be taken.

Scenario 1: aGate and electrical conduits share the same side of the wall.

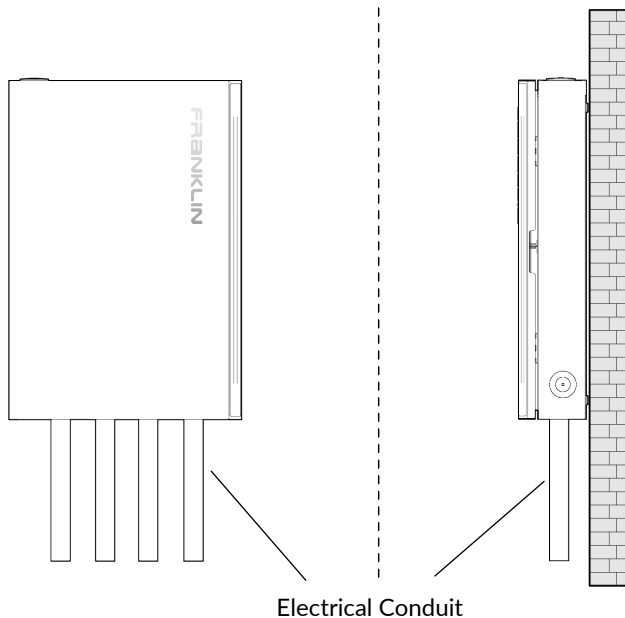

If the aGate is installed outdoors, the electrical conduit is connected to aGate through the cable inlet on the upper panel. Water-proof sealant or caulk should be used between the reducing fitting, hub, electrical conduit, and aGate to enhance the water tightness.

Scenario 2: Cables are run in electrical conduits and enter aGate from inside or through the wall.

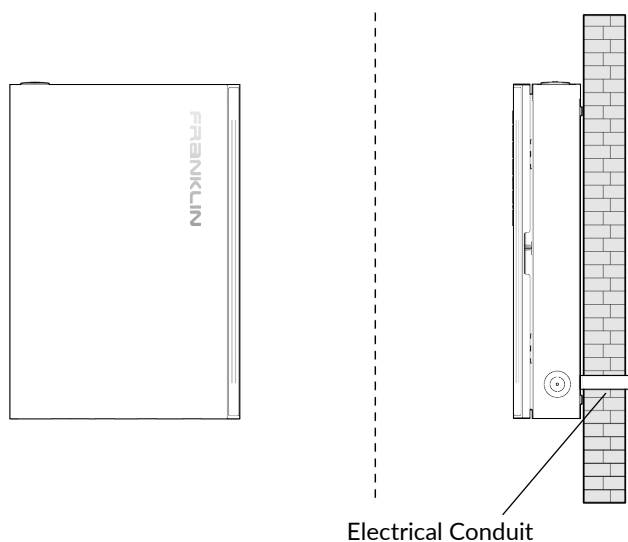

In this case, a conduit hub will be needed to ensure the IP grade of the aGate.

3. Plan protection for aGate's input connections

The aGate serves as the entrance to the FranklinWH system. Proper lightning and over-current protection measures are required. A circuit breaker of 100 A to 200 A may be installed at the grid input connection and the generator input connection. Please refer to [Install breakers as needed](#) in this Guide for the recommended models of circuit breakers.

4. Plan the types, sizes and routes of cable and electrical conduits

- a) Please refer to [Wiring Requirements](#) for recommended cable types and wire diameters.
- b) As cables run through the electrical conduits:
 - The current-carrying capacity of the cables needs to be reduced. Please refer to the applicable information in Appendix B of NFPA 70.
 - The relationship between wire diameters, cable numbers, and inner diameters of conduits should be taken into consideration. Please refer to Appendix C of NFPA 70 for the list of maximum numbers of cables of the same size in the electrical conduits and pipelines.
- c) The type of electrical conduits depends on the installation type, indoor or outdoor:
 - IMC, EMT and other thin-wall metal conduits are recommended for indoor installations. These two types of conduits are cost effective, provide excellent anti-electromagnetic interference, and are easy to shape and to joint.
 - In outdoor installations, GRC and RMC thick-wall conduits are recommended because they can provide effective mechanical protection and good tightness at the conduit joints. Thick-wall conduits have a reduced flexibility disadvantage which makes bending and jointing very difficult.

5. Plan the Fire Control and Extinguishing System

The selection and installation of fire control and extinguishing systems on power storage systems must comply with the requirements of NFPA855 and local fire authorities.

6. FCC Requirements

See preface for the applicable FCC Requirements. The installer should inform customers of the contents in Appendix 2.

Tools Needed

- Personal Protection Equipment (PPE) (goggles, gloves, protective shoes, anti-dust respirator, etc.) for personal safety.
- Drill
 - ✓ Use 5/32" Brad Point bits or 5/32" Auger bits to drill pilot holes in wooden walls.
 - ✓ Use 1/2", 3/4", 1", 1-1/2", 2" sized wood bits to create holes in wooden walls.
 - ✓ Use 1/2", 3/4", 1", 1-1/2", 2" sized hole saw bits to create holes in metal walls.
- Hammer drill
 - ✓ Use 1/2", 3/8" Masonry bits to create pilot holes on concrete or brick walls.
 - ✓ Use 1/2", 3/4", 1", 1-1/2", 2" Diamond core bits to create holes in concrete or brick walls.
- Electric screwdriver and cross screw bits to tighten the fastening screws.
- Torque wrench and bent-handle ratchet wrench.
 - ✓ 11/32", 5/16", 7/16", and 3/8" hex sockets, to tighten and check the torque of outer hex bolts.
 - ✓ 3/16" and 7/32" inner hex screwdriver bits to fasten cables at circuit breakers and pressure connectors and to check the torque.
 - ✓ 3/16", 1/4" straight screwdriver bits to fasten cables at circuit breakers and connectors and to check the torque.
 - ✓ PH2, PH3 cross screwdriver bits to fasten cables at circuit breakers and to check the torque.
 - ✓ 6" ratchet extension.
 - ✓ 1/4" open end interchangeable torque wrench to fasten relays and to check the torque.
- Flat head screwdriver (1/8" x 4", 1/4" x 4") to fasten signal terminals.
- Phillips head screwdrivers (PH#2 x 4", PH #3 x 4") to tighten fasteners.
- Claw hammer to break knockout holes.
- Utility knife to cut open boxes.
- Needle nose, vise grip, wire stripper, wire cutter, utility wire shear, and other cable preparation tools.
- Wire crimper, network cable testers, wire tracker, and other network cable preparation tools.
- Induction electro probe to detect the cables in walls to avoid short circuits when drilling.
- Multimeter to measure voltage, current and other electric parameters.
- Loop resistance tester to measure the wiring resistance and to detect poor connection of cables.
- Task light to illuminate the area when power supply is off.
- Level to check whether the equipment is installed on level.

- Steel measuring tape.
- Markers for drilling marks.
- Camera to record the installation process.
- Deep cut band saw to cut thin-wall steel conduit or PVC pipes.
- Lift equipment to transport and lift aPower.
- Conduit bender to bend thin-wall steel conduits, with the head size depending on the types and sizes of conduits, with $\Phi 1/2''$, $3/4''$, $1''$, $1-1/2''$, $1-1/4''$, $2''$ benders.
- Knockout tool kit to drill holes for conduits on the distribution box case.
- Wooden block, size: 1.75 in. \times 26.77 in. \times 2.36 in. (44.4 mm \times 680 mm \times 60 mm).
- Adjustable wrench, size: 0-1.97 in. (0-50 mm).
- 6", 10", 18" pipe wrenches.

Torque Requirements

Screw type	Cross head screwdriver	Tightening torque
M4	PH2	1.03 lb·ft (1.4 N·m)
M5	PH2	2.21 lb·ft (3.0 N·m)
M6	PH3	4.42 lb·ft (6.0 N·m)
M8	PH3	8.85 lb·ft (12.0 N·m)

Items Provided by Installers



1	Electrical conduit, conduit hub, pull box and fittings
2	Screws and M6/M8 big spacers for wall installation
3	aPower combiner box (for parallel operation of multiple aPower units)
4	5/8 in. Type X plasterboard
5	Copper or aluminum cables
6	Circuit breakers. For details, refer to the circuit breaker and optional parts section for circuit breaker models
7	Reducing washer conduit fittings
8	Network cable and registered jacks
9	Antioxidant conductive paste
10	Sealant (for use on outdoor conduits)

Unboxing

Unbox the aGate

- 1) Inspect the package for damage, scratches or dents.

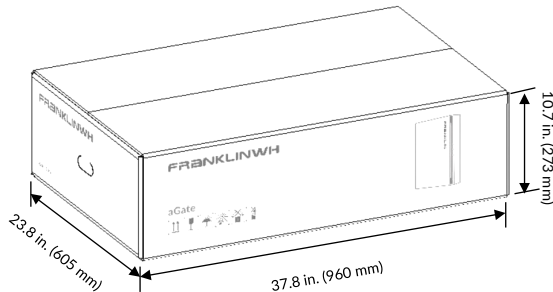

- 2) Adjust the utility knife blade to less than 0.3 in. (7.62 mm) as it may damage the aGate if too long. Cut the adhesive tape on the upper surface of the aGate box.
- 3) Open the aGate box, take out the template guide board and accessories, and then take the aGate out of the box.
- 4) Check if you have the following:



1	2	3	4
aGate	Switch tag	Grid relay reset handle toggle	1/4" water-tight washer
5	6	7	8
Cable ties	Main switch mounting screw M4 × 10	aPower breaker fastener	5m communications cable

- 5) Remove the packing foam from both sides of the aGate and remove the PE bag.

Unbox the aPower

- 1) Inspect the package for damage such as dents or scratches.

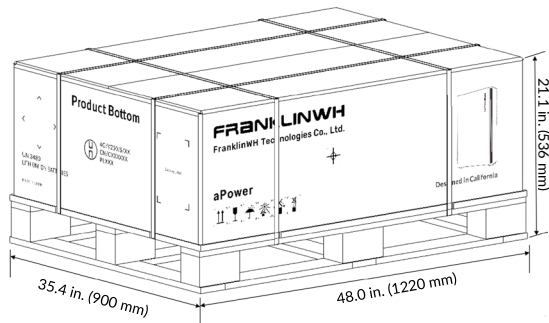

- 2) Cut the sealing tape and lift the cardboard cover.
- 3) Remove the protective box and top foam.
- 4) Check if you have the following:

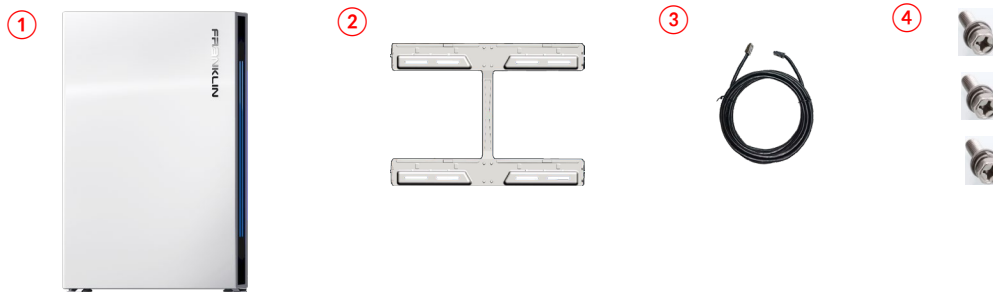

1	2	3	4
aPower	Mounting bracket	2 m communications cable	M6 x 16 screw

- 5) Stand the aPower upright (logo faces up). Several installers should work together to prevent the equipment from falling.
- 6) Using a lift, move the aPower to the installation site.



NOTE: Wrap the aPower in a protective blanket and keep the aPower well fastened to the dolly during transportation and handling to avoid scratches or damage.

Installation



DANGER: Care must be taken to protect personal safety. Reinforced toe shoes must be used to protect the installers in case equipment tilts or falls.



aGate Installation



WARNING: Add lightning protection measures per NFPA 780, UL96A, and LPI-175.

NOTE



- The drill template guide board will be used for drilling mounting holes. Keep it in good condition prior to use.
- The film wrapped around the aGate will be used to protect the internal components of the aGate when drilling mounting holes. Do not damage or dispose of the film until the drilling is complete.
- During the installation process, keep the aGate well protected from hard objects that may scratch the aGate surface and body.

Remove the aGate Door and Inner Panel

1) Remove the door

- a) Grasp the small notch on the right side of the aGate. Lift it slowly until the door of aGate is completely open.

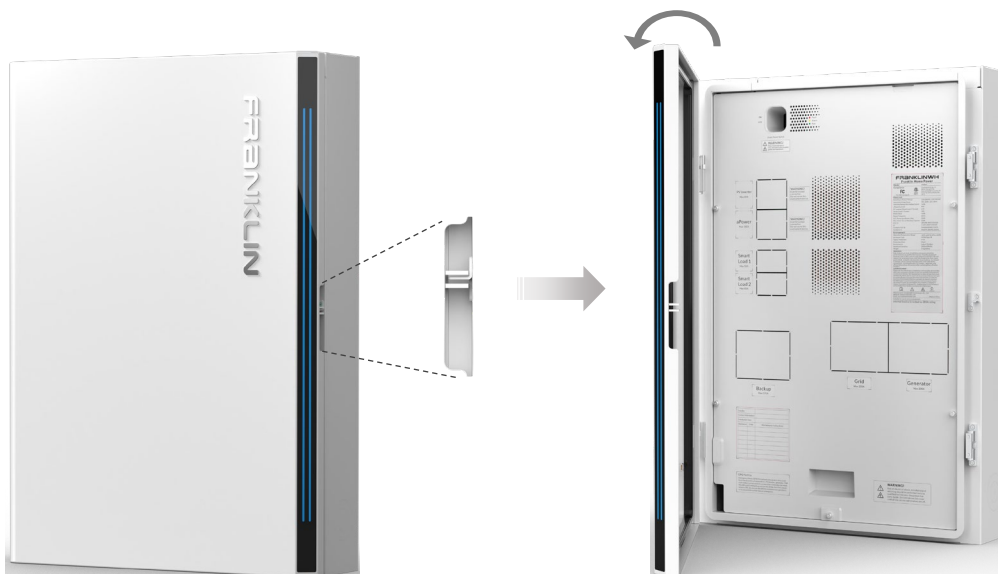

WARNING: The door may only be opened to a maximum of 100°, beyond which the door may be damaged.

- b) Gently lift the door panel upward, remove the aGate door after the hinges are separated, and properly store it.

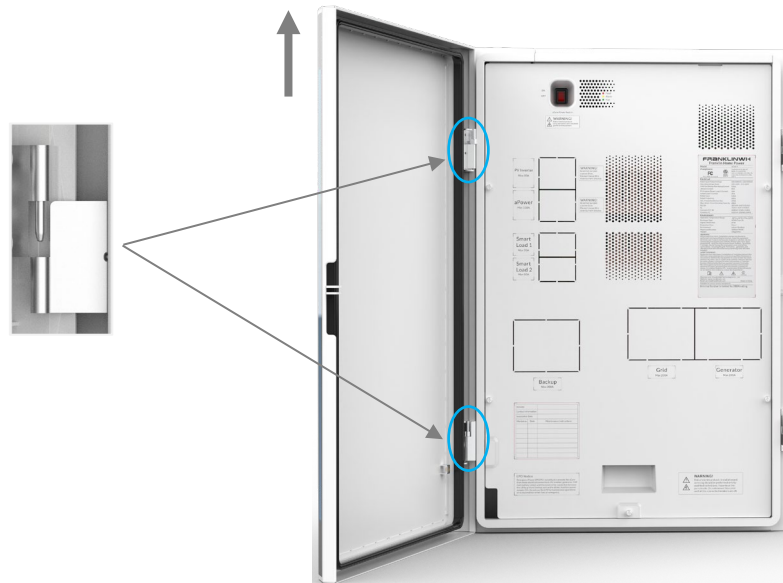

2) Remove the Inner Panel

Use a Phillips head screwdriver to loosen the 5 captive screws, counterclockwise. Remove the screws, and the aGate inner panel. Properly store the inner panel and screws for later use.

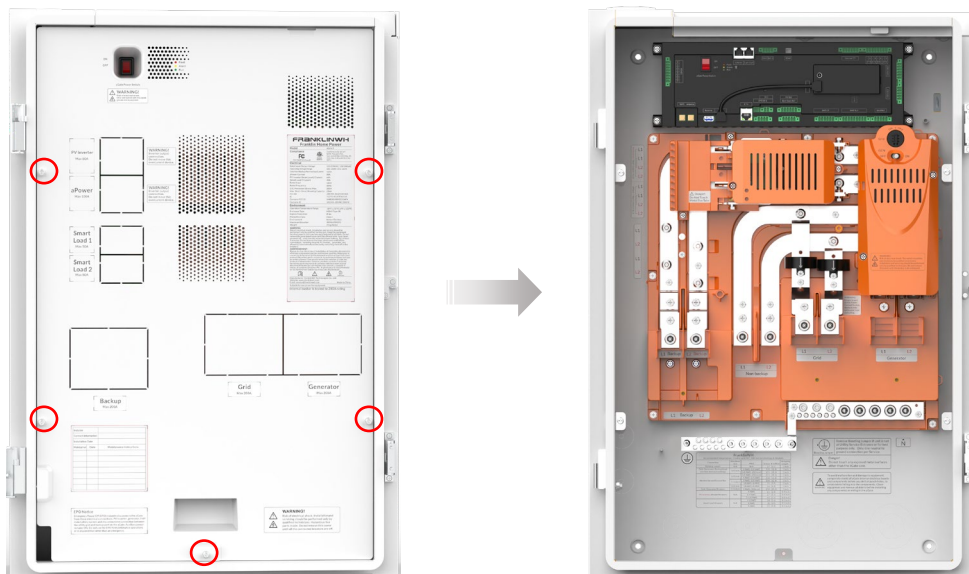

Prepare aGate Cable Inlets

Based on the preplanned installation position and electrical conduit arrangement, remove the appropriate aGate plug or knockouts.

1) Remove the plug

The plugged hole on the top of the aGate enclosure is 2-15/32" (62.71 mm) in diameter. If the top cable entry is used, turn the plug nut counterclockwise by hand, until the nut is removed, then remove the plug.

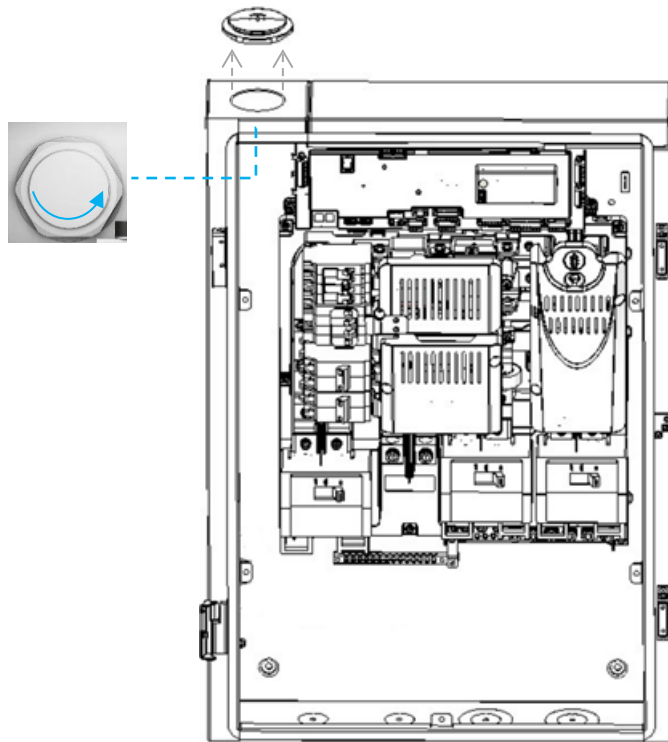

WARNING: It is recommended to install cables through the bottom of the aGate. If a top inlet cable is installed, waterproofing measures must be taken.

2) Remove the knockouts

All cable knockouts in the aGate enclosure are 1-23/64" (34.53 mm) in diameter with the two on the bottom right, and the one on the right side can be expanded to 2-15/32" (62.71 mm).

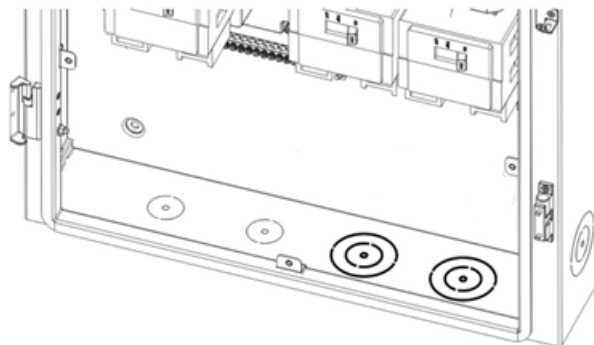

Drill out the necessary cable access holes from the aGate.

Enlarge or Drill New Holes (if necessary)

If the conduit diameter is larger than the aGate knockout hole, or if any new hole needs to be drilled, appropriate tools should be used to expand the hole or to drill new holes.



WARNING: To avoid damage to equipment, shield all aGate interior electrical boards and components before you drill or punch holes, to avoid debris falling into the aGate.

The aGate is shipped in a protective film. When enlarging or drilling new holes on the aGate, unwrap the outer film and use it to protect the components inside the aGate. Keep the film in place while drilling and punching holes. Remove all dust and debris before unwrapping the aGate for mounting.

White film wrapped on delivery



Internal components protection



Mount the aGate on a Wall

Follow the procedures below to install the aGate on a wall.

- 1) Place the aGate guide board template at the planned installation position. Adjust the guide board to level and then make marks at the four holes on the guide board.
- 2) Using an appropriate drill bit, drill holes in the wall. Then mount the aGate enclosure vertically on the wall. The water-tight washers provided must be used when mounting the aGate.



DANGER: Avoid drilling holes in water pipes and cables in the wall.



WARNING: Cover any nearby aPower top heat dissipation hole during drilling to protect from gravel dust.

See drilling details and the fasteners in the table below for more details on the hole depth and type of fasteners to use corresponding to different type of wall.

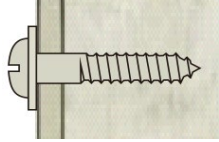
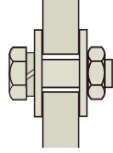
<p>Concrete or brick</p>	<p>Hole depth: Minimum 1-1/2" (38 mm) Fastener: 1/4" (6.35 mm) water-tight washer, spring washer, and nuts</p>	
<p>Wooden beams</p>	<p>Hole depth: Minimum 2.5" (64 mm) Fastener: 1/4" (6.35 mm) water-tight washer, wood screw with a large flat washer</p>	
<p>Steel beams</p>	<p>Hole depth: Through the steel beam Fastener: 1/4" (6.35 mm) water-tight washer, 1/4" (6.35 mm) stainless steel hex screws with spring washer and large flat washer and hex nuts</p>	

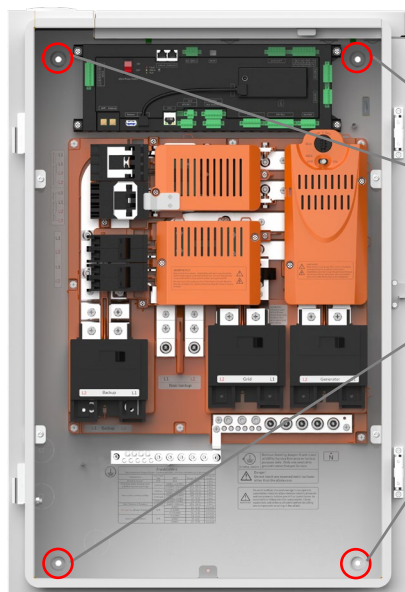

For demonstration only.
 Use fasteners specified in the table above.

Install Optional Module(s)

FranklinWH provides optional the Smart Circuits Module, Generator Module, Main Load Relay, and Backup Expansion Lug Kit. For these modules' installations, refer to **FranklinWH Smart Circuits Module Installation Guide**, **FranklinWH Generator Module Installation Guide**, **FranklinWH Main Load Relay Installation Guide** and **FranklinWH Backup Expansion Lug Kit Installation Guide**.

Install Breakers as Needed

Install any needed breakers for PV, aPower, Smart Circuits, the backup panel, grid, and generator, according to local laws, regulations, standards, and National Electric Codes (NEC), ANSI/NFPA 70 or Canadian Standards Association CSA C22.1. These breakers are not included and must be ordered separately. Refer to [Appendix 1](#) for compatible breakers.

Breaker installation positions are noted in the image below:

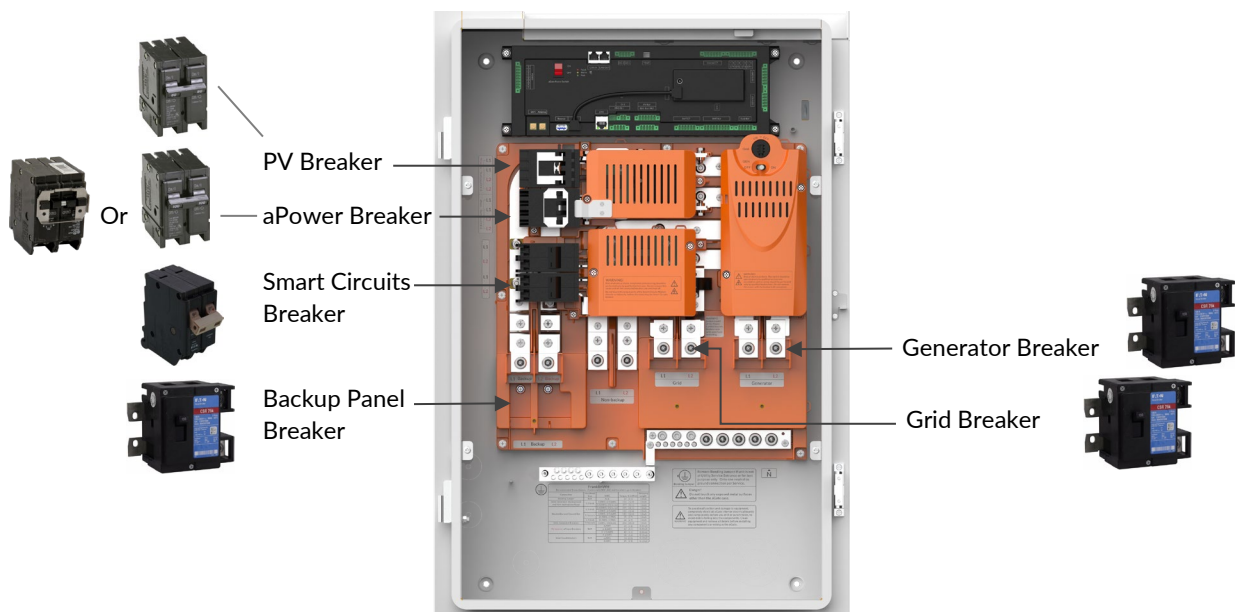

- 1) Before installation, make sure that the aGate is de-energized and the upstream and downstream switches are disconnected and padlocked during installation.
- 2) Install the PV breaker, an aPower breaker, and Smart Circuits breakers at the locations indicated in Figure 1.

- 3) Fasten the aPower breaker according to the following steps as per NEC requirements.

Install the breaker hold-down kit as shown in the diagram. Tighten the two M4x8 screws to the recommended torque using a Phillips screwdriver.

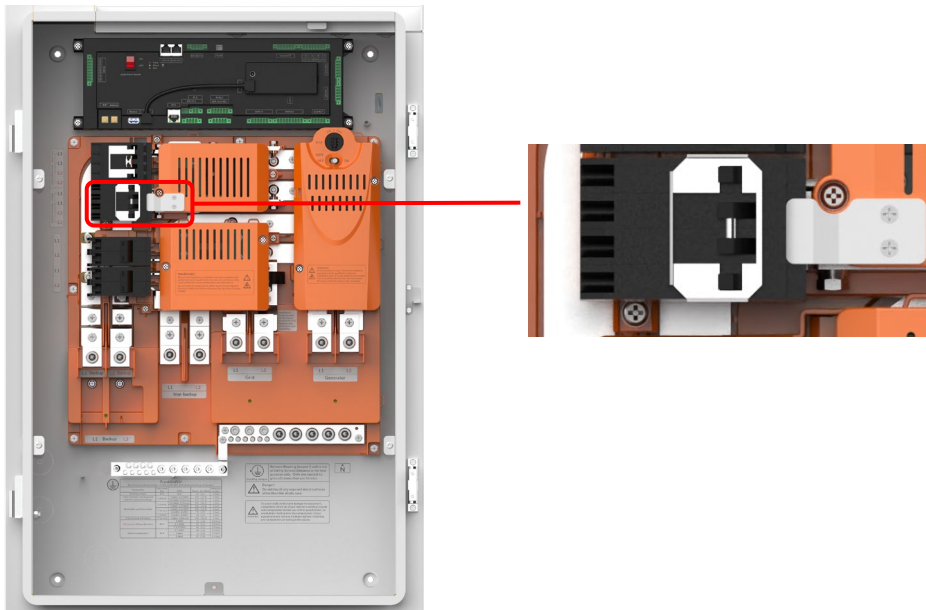

- 4) Before installing a backup panel breaker, a grid breaker or a generator breaker, remove the connected lugs. Follow the instructions below to remove the lugs and install the breakers:
- Using a Phillips head screwdriver, remove the two M6 x 16 combination bolts holding the lugs and save it for later use. Remove the lugs.
 - Use the two M6 x 16 combination bolts to fix the breaker. Then use the M4 x 10 screw to secure the breaker. Using a Phillips head torque screwdriver, tighten the M4 screw to 1.03 lb-ft (1.4 N·m).
 - Attach the provided **L2 Backup L1**, **L2 Grid L1**, and **L2 Generator L1** labels below the backup panel breaker, the grid breaker, and generator breaker.

Removing the terminal lugs to install a backup panel breaker, a grid breaker, or a generator breaker.

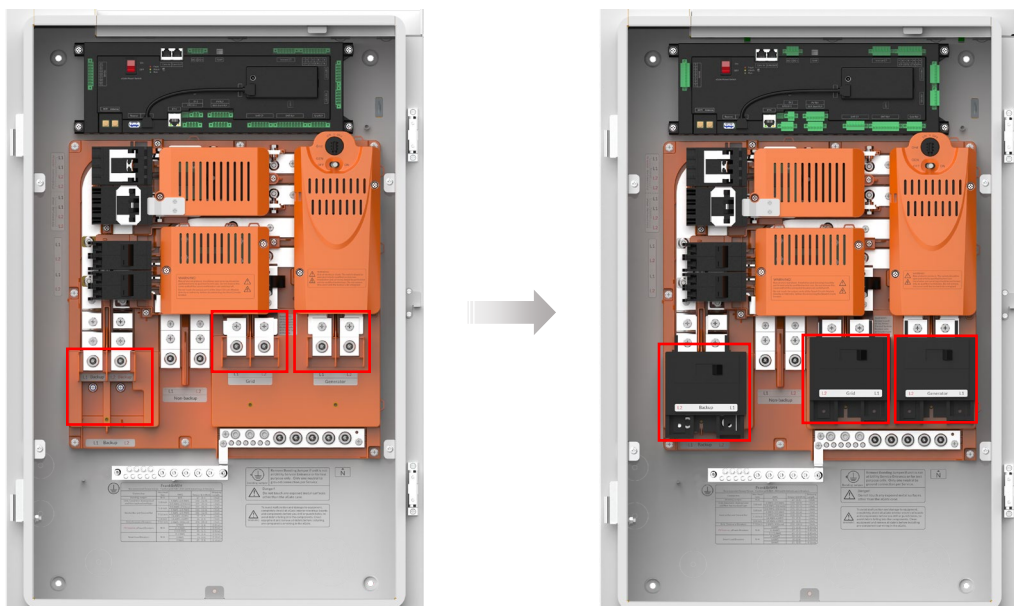



NOTE: The aGate's utility grid circuit breaker is only required where the aGate is used as service entrance equipment or there are no other circuit breakers protecting the conductors feeding the aGate's utility grid connection.

The generator breaker may be installed outside the aGate depending on site conditions.

aPower Installation

The aPower can be mounted either on the wall or on the floor. Floor mounting is recommended. Choose a location that can structurally support the weight of the aPower.

Wall-Mounted Installation

Install the mounting bracket

- 1) Before installing, examine the smoothness of the wall.

If the wall is not smooth and straight to the floor, Type X plasterboards will be needed to fill the gaps to ensure all parts of the mounting bracket are well supported by the wall.

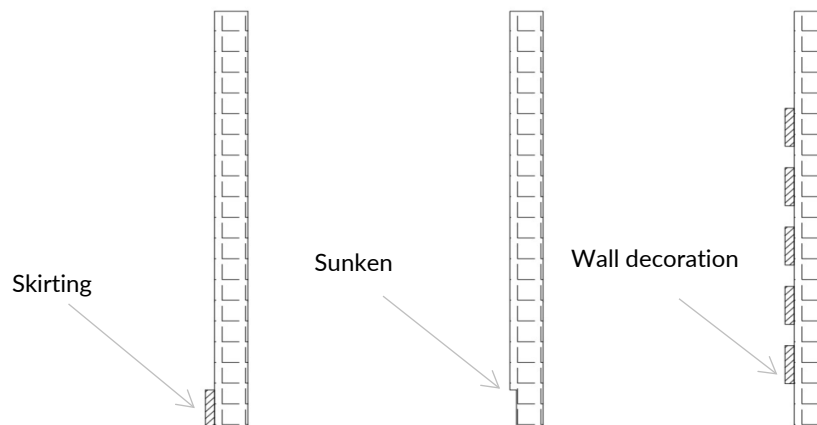

Special Wall/Baseboard Installation

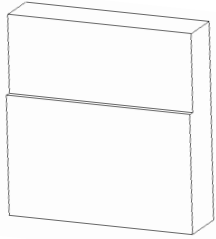
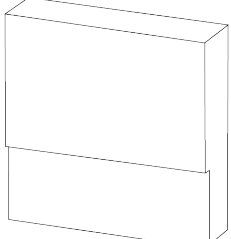
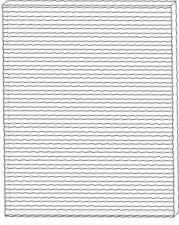
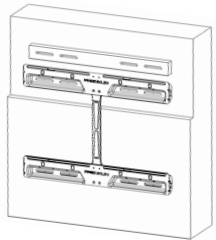
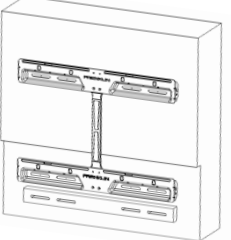
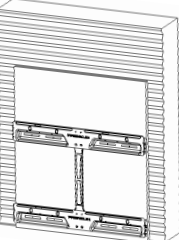
<p>Case 1: Protruding Baseboard Height > 6 in. or the thickness of the bulge > 1 in.</p>	<p>Case 2: Concave Baseboard Height > 6 in.</p>	<p>Case 3: Uneven Wall</p>
		
<p>Solution Use wooden or steel spacers on the upper part of the bracket (to keep it flush with the baseboard).</p>	<p>Solution Use wooden or steel spacers on the indented part of the baseboard (to make it flush with the wall).</p>	<p>Solution Use plywood or gypsum board to level the wall. The recommended thickness is 0.5 in.</p>
		



NOTE: The wooden or steel materials are prepared by the installer.

2) Determine bracket attachment points

The mounting bracket should be fastened to the wall at a minimum of 4 points, one on each arm. When the bracket is attached in an outdoor, windy area, at least 8 5/16" screws (2 at each corner) should be used to install the bracket.

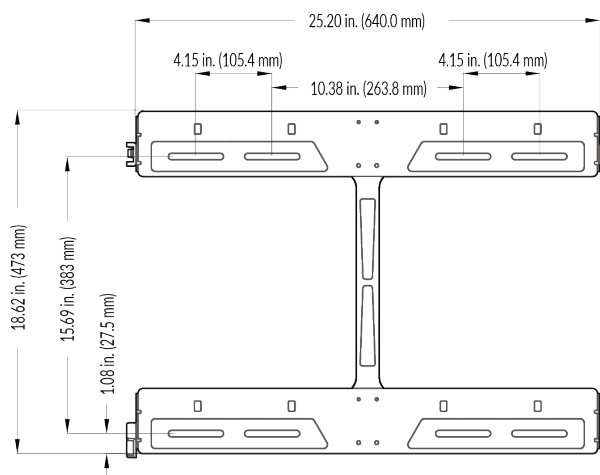

Determine bracket attachment points following the methods described below.

a) Method 1: Use the bracket to mark the points.

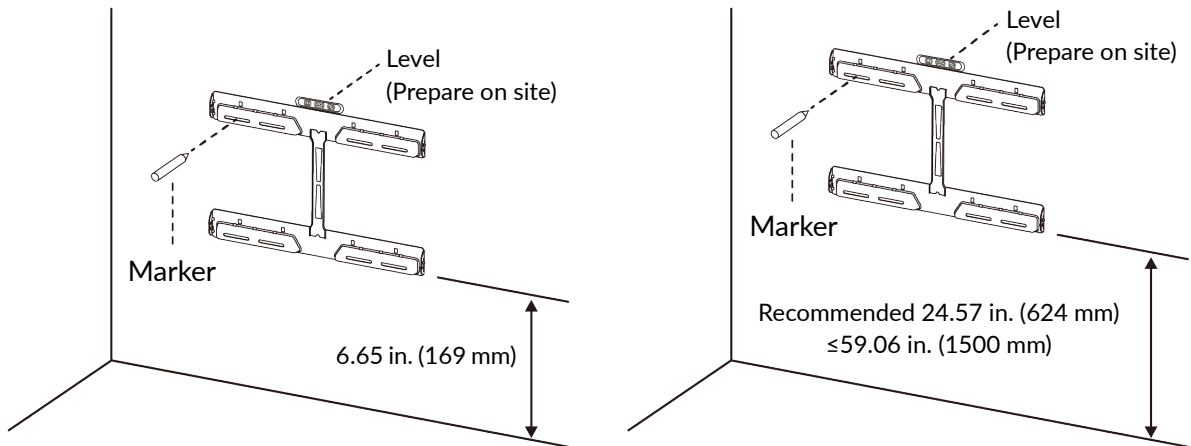

- ① Place the mounting bracket at the planned installation position and support the mounting bracket using a 6.65 in. (169 mm) thick wood block.
- ② Use a level to adjust the installation angle.
- ③ Make marks through the mounting holes where the fasteners will be used.

b) Method 2: Use the cardboard mounting template to mark the points.

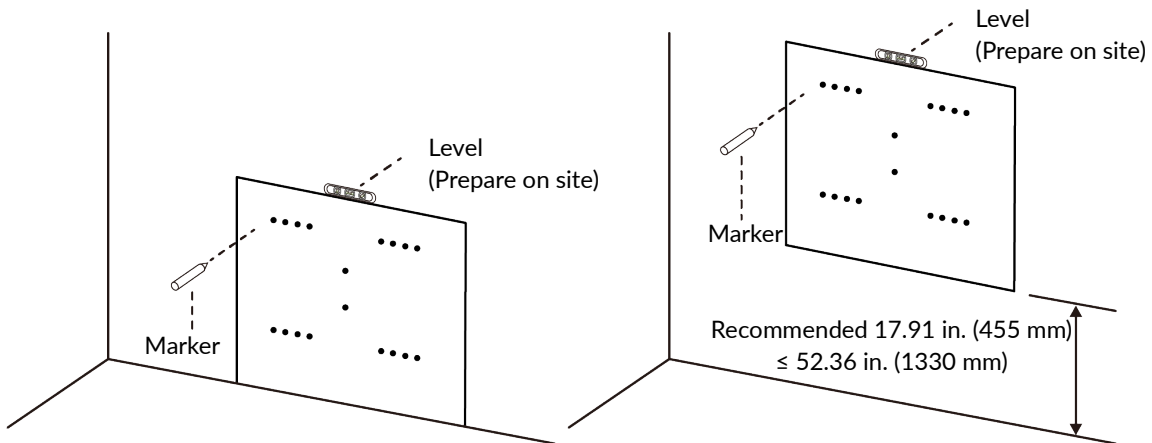

- ① Place it against the wall in the planned installation position according to the orientation of the cardboard text (the bottom of the cardboard is on the ground when it is installed on the ground).
- ② Use a level to adjust the installation angle.
- ③ Make marks through the mounting holes where the fasteners will be used.

3) Install the bracket on a wall

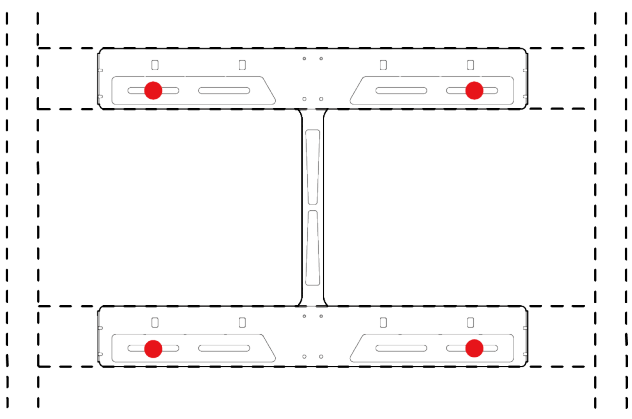
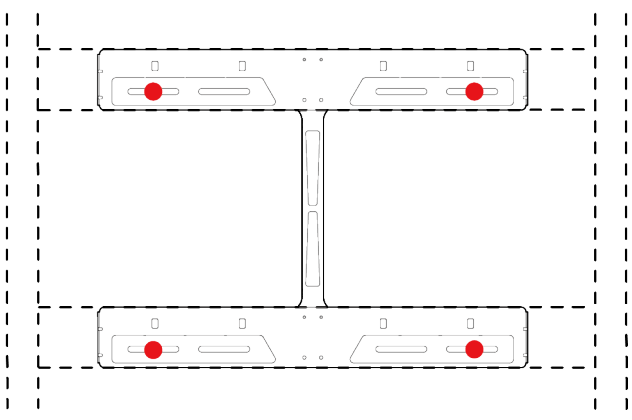
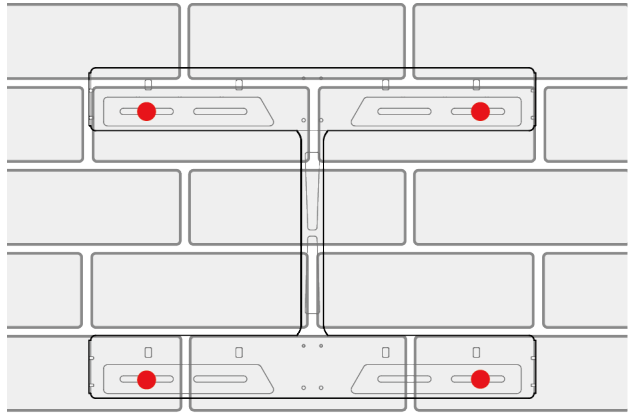
<p>Wooden beams</p> <p>At least 4 5/16" stainless steel wood screws with large flat washers (1 at each corner), at least 2.5" (64 mm) of each screw inserted into the wooden beam.</p>	
<p>Steel beams</p> <p>Use at least 4 5/16" stainless steel hex screws (1 at each corner) with spring washers, large flat washers and nuts to secure the bracket to the steel beam.</p>	
<p>Concrete or brick walls</p> <p>Use at least 4 5/16" stainless steel expansion screws (1 at each corner) with spring washers and large flat washers and at least 1.5" (38 mm) length embedded in the wall. Place screws at least 1.5" (38 mm) away from brick edge.</p>	

Drill conduit entry holes on the wall (if needed)

If needed, drill conduit entry holes on the wall. If there are any metal or wooden supporting structures in the drilling area, adjust the position to avoid them.



DANGER: Avoid drilling holes in water pipes and cables in the wall. PPE must be worn.



WARNING: Cover the aPower top heat dissipation hole to protect from gravel dust during drilling.

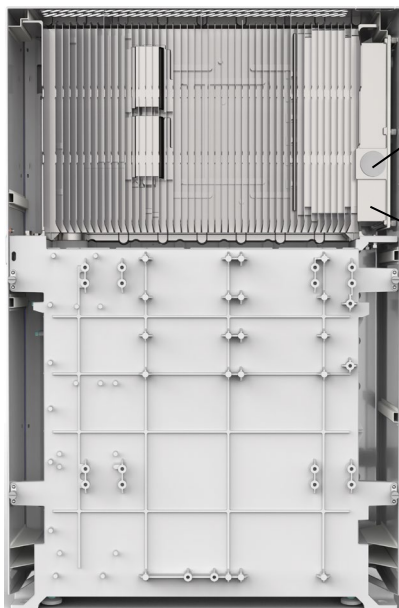

Rear View

Power cable conduit
Reserved output for Signal cable conduit

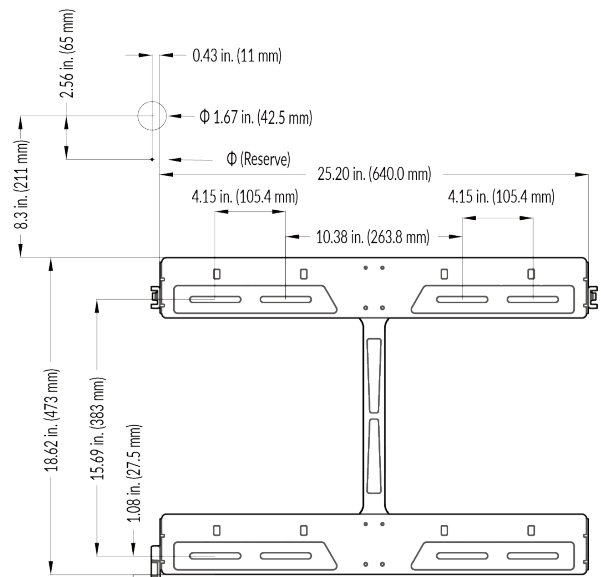

Front View: Location of conduit entry hole in position to bracket

	<p>Wooden wall</p> <p>Electric drill and 1", 1-1/2" wood bits are recommended to create holes for running cable through wooden walls.</p> <p>It is important that the drill bit be kept perpendicular to the wall when drilling.</p>
	<p>Concrete or brick wall</p> <p>Hammer drill and 1", 1-1/2" diamond tipped core bits are recommended to create holes for running cables through concrete or brick walls. Wet the wall and HEPA vacuum the dust, to protect the drill bits from overheating.</p> <p>It is important that the drill bit should be kept perpendicular to the wall when drilling.</p>



Metal wall or metallic studs

Electric drill and 1", 1-1/2" hole saw are recommended to create holes for running cables through metal plate and metallic studs.

It is important that the drill bit should be kept perpendicular to the installation surface when drilling.

Mount the aPower on the bracket



DANGER: Special care must be taken to protect personal safety. Reinforced toe shoes must be used to protect the installers from tilting and falling equipment.



WARNING: Use proper protective measures on the lift, such as foam or protective cloth, and take effective protection measures to avoid scratching or damaging the aPower during the installation process.

- 1) For transportation, secure the aPower to the dolly using straps. Raise the aPower to position the rear mounting cleats slightly higher than the mounting bracket. Move the dolly so that the aPower is in mounting position. Slowly lower the aPower so that the four mounting cleats snap securely onto the mounting bracket.

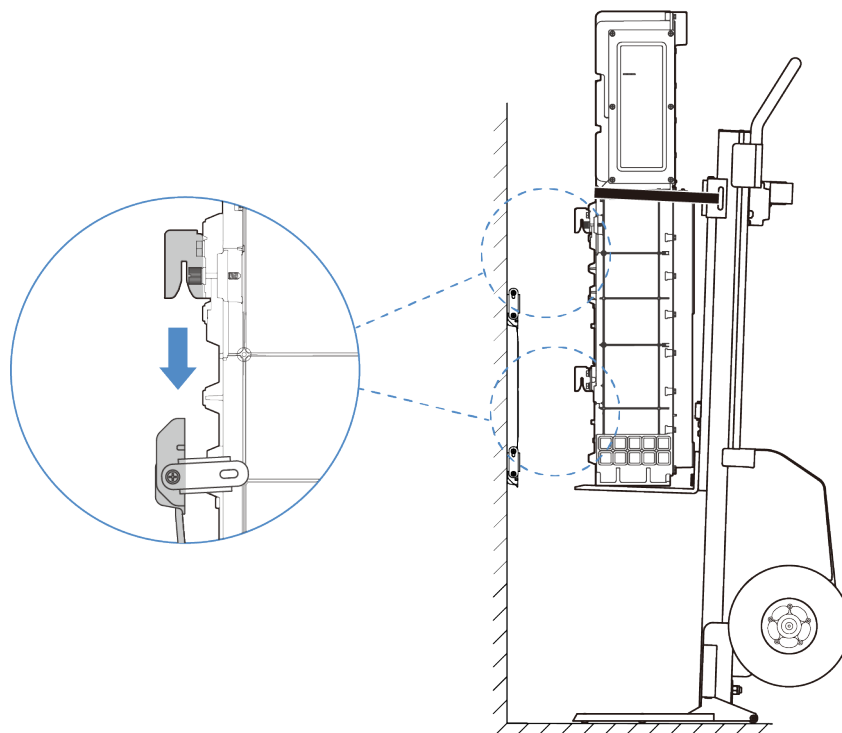

- 2) After the aPower is firmly on the mounting bracket, fasten the three retainer plates to the aPower using three M6 x 16 screws. Tighten to a torque of 3.7 lb·ft (5 N·m).

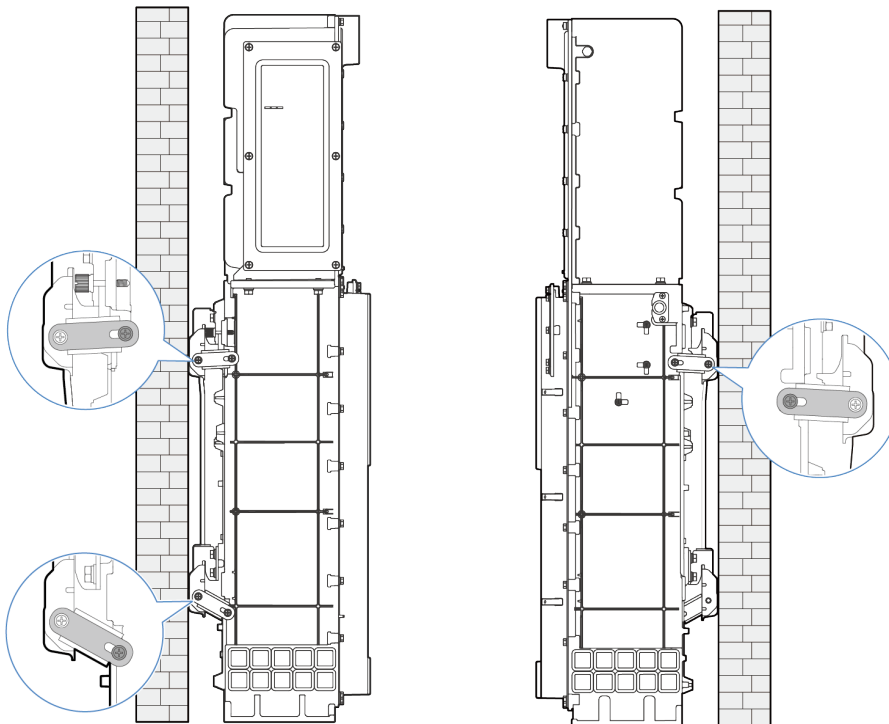

Floor-Mounted Installation

Installation site requirement

Perform a site assessment before installation. The poured concrete pads must have a minimum compressive strength of 3,000 PSI. And the concrete reinforcement must meet the temperature and shrinkage control requirements of ASTM A615 Grade 60, with a yield strength of 60,000 PSI.

Mount the aPower on a solid surface, such as a concrete floor, with an area exceeding 10.76 ft² (1 m²) and a minimum depth of 5.9 in. (150 mm). The aPower should be attached to a floor mounting bracket and maintain a minimum distance of 1.18 in. (30 mm) from the ground to the bottom of the aPower.

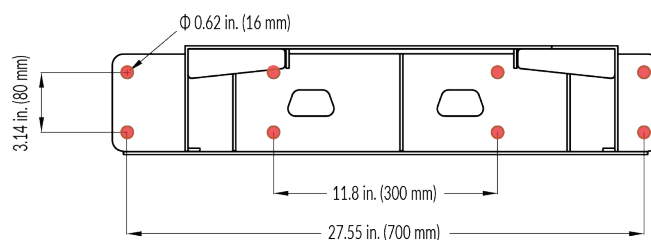

When the concrete floor is uneven, it is recommended to use steel plates of different thicknesses to level. Keep the aPower perpendicular to the horizontal plane during installation.

NOTE



Steel plates of different thicknesses are pre-fabricated by the installer.

The floor mounting bracket meets the strength requirements specified by IEC60721-3-3 recommended grade 3M4 sinusoidal vibration test conditions.

Install the floor mounting bracket

Choose a smooth and level concrete area with sufficient structural strength to support the weight of the aPower.

1. Mark eight mounting holes for drilling on the floor using the floor mounting bracket or cardboard mounting template as a guide.

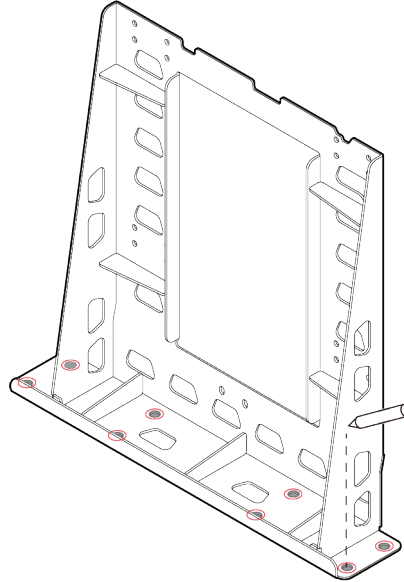

2. Drill holes at the marked spots.
The drilling depth should be at least 4.72 in. (120 mm), and diameter should be Φ 0.62 in. (16 mm).
3. Secure the floor mounting bracket to the floor with eight 1/2" expanding anchor bolts. Tighten the nuts to a torque of 73.8 lb·ft (100 N·m).

Mount the aPower to the floor mounting bracket

1. Remove the sixteen combination screws (M 8 x 16) and the four mounting cleats. Properly store the combination screws for later use.

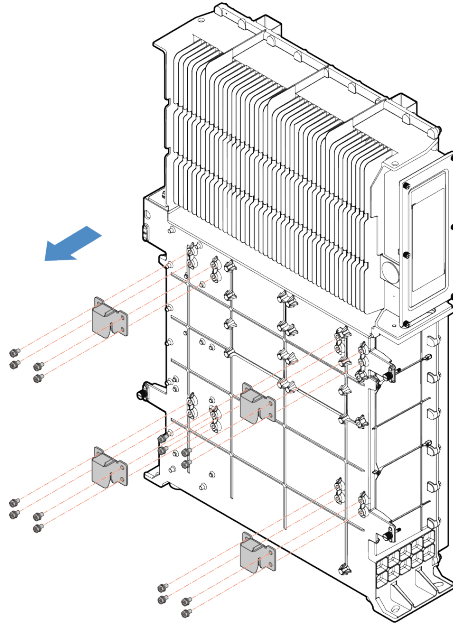

2. Hang the aPower on the floor mounting bracket and secure with the sixteen combination screws (M 8 x 16) that were previously removed and the two supplied M8 x 16 screws. Maintain a minimum distance of 1.18 in. (30 mm) from the ground to the bottom of the aPower.

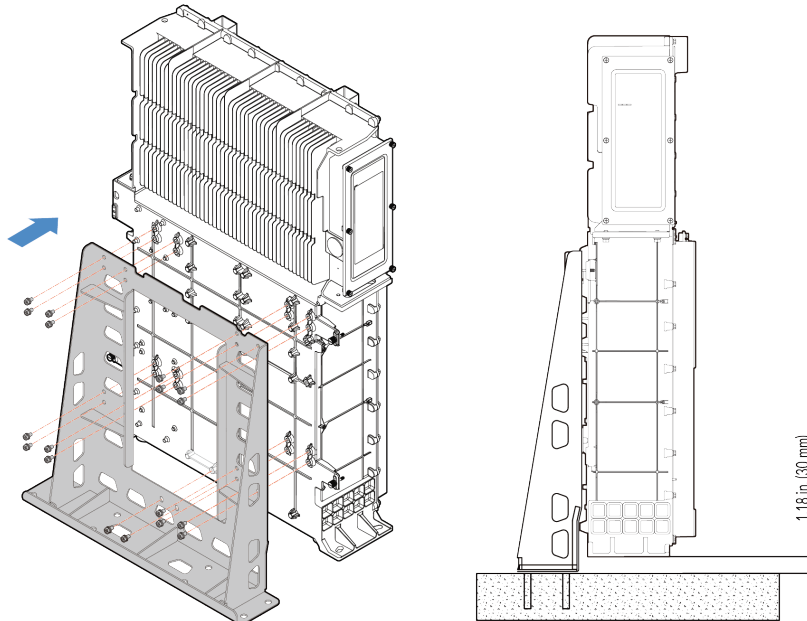

Install a Combiner Box (if needed)

The installation of more than two aPower units requires a combiner box. Each aPower should be connected to a 2-pole breaker. Select a suitable external combiner box and provide breakers for each aPower unit. For details, refer to [Install breakers as needed](#).



NOTE: Refer to the manufacturer's instructions before installation.

System Wiring

Install Electrical Conduit in the aPower Wiring Compartment

- 1) Loosen the six captive screws and remove the wiring compartment cover.

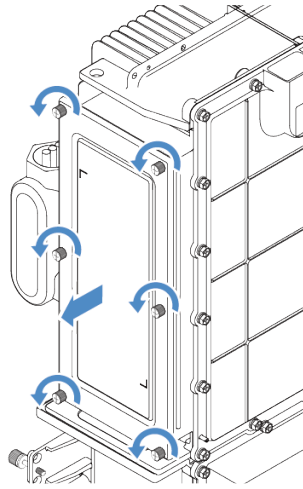

- 2) Unplug the communications cable, power cables, and ground wire.

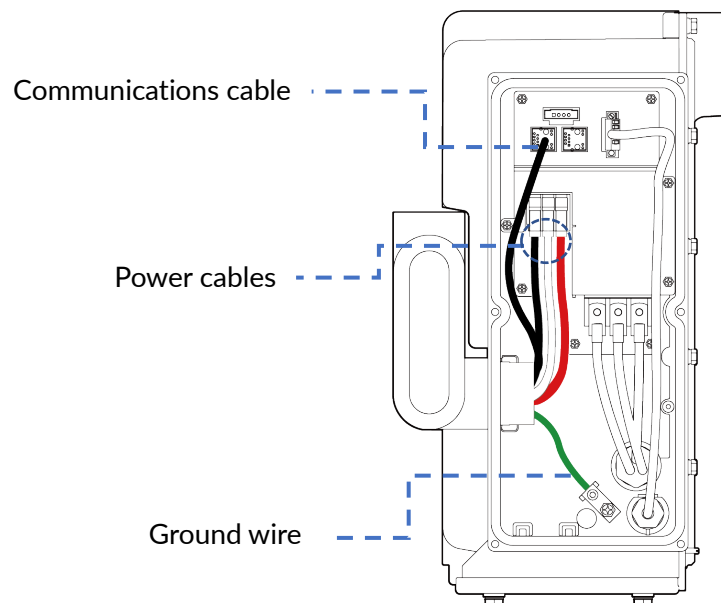

- 3) As needed, install a pull box behind a Power cable hole.
 - a) Select an appropriate pull box according to the cable distribution direction (The figure below is for reference only).

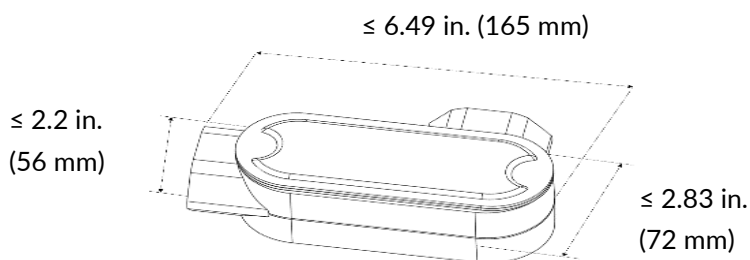

- b) Use a Phillips head screwdriver to disassemble the junction box. Install the pull box on the selected cable entry.

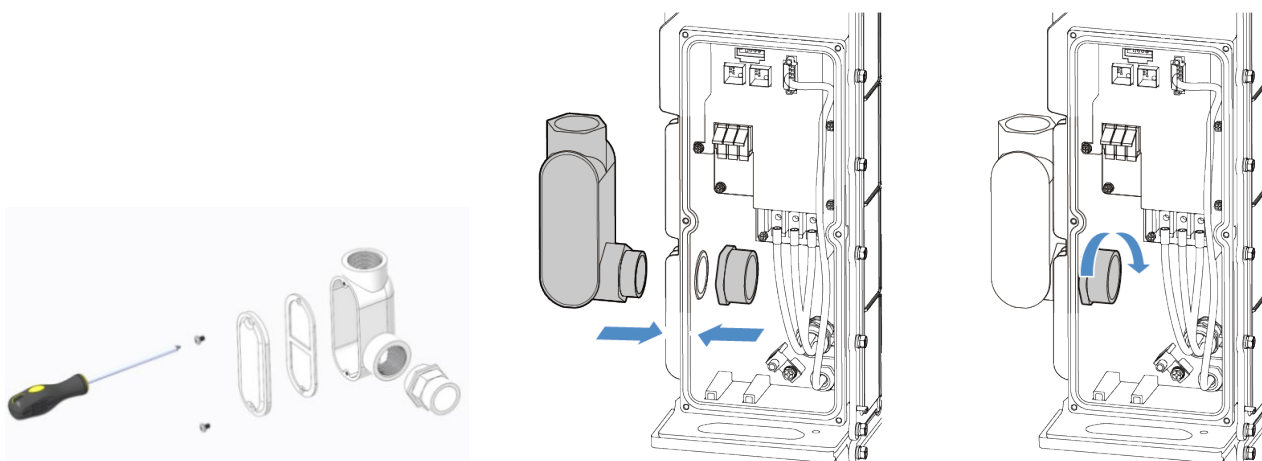

4) Conduit Connection and Installation

Install conduit as needed and attach the conduit fitting to the cable entry of aPower wiring compartment.

The image below shows an example of conduit and fitting for different applications.

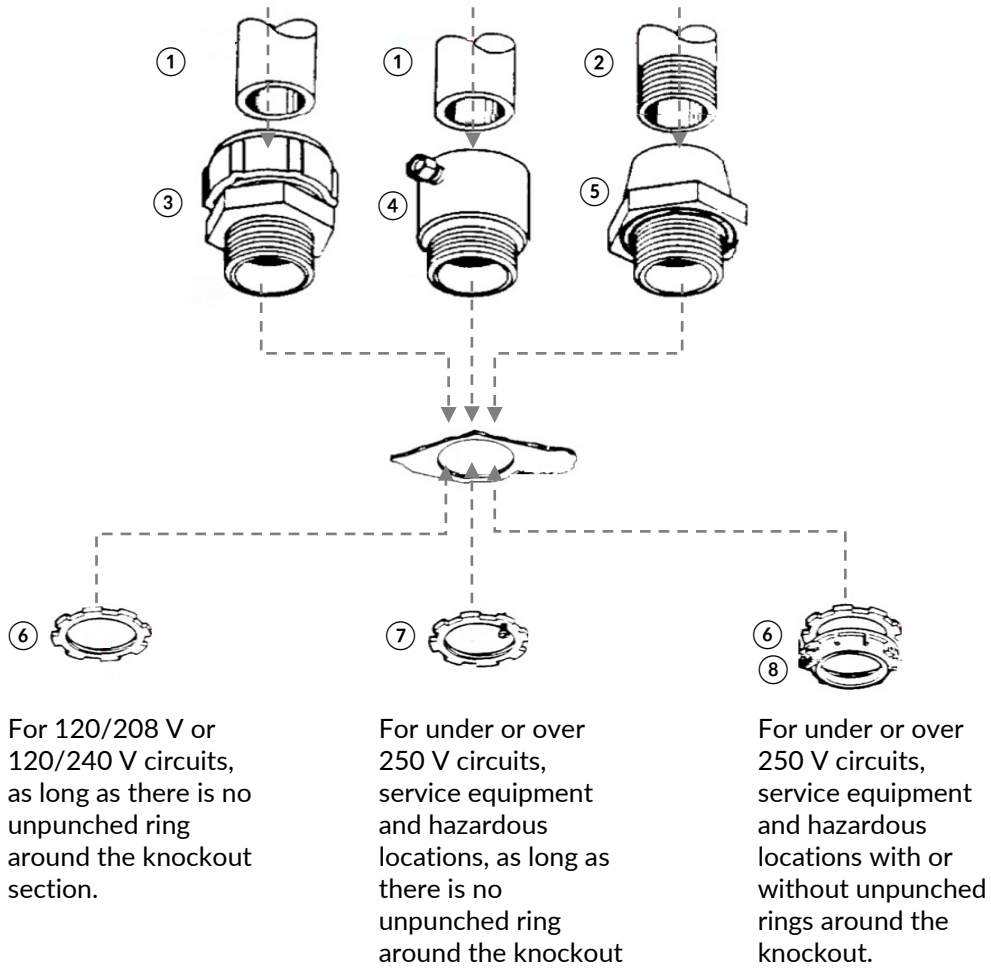

No.	Description
1	Threadless rigid metal conduit or intermediate metal conduit.
2	Threaded rigid metal conduit or intermediate metal conduit
3	Threadless fitting
4	Screw fitting
5	Sealing hub
6	Locknut
7	Bonding knockout
8	Bonding & grounding bushing



WARNING: The conduits and related materials must comply with UL746B requirements as well as all local laws and regulations.

Metallic conduits and fittings are recommended to minimize electromagnetic interference.

Communications Wiring

Before wiring, ensure that the Com Kit (4G) cable is connected between the Com Kit port on the EMS module and the 4G module.

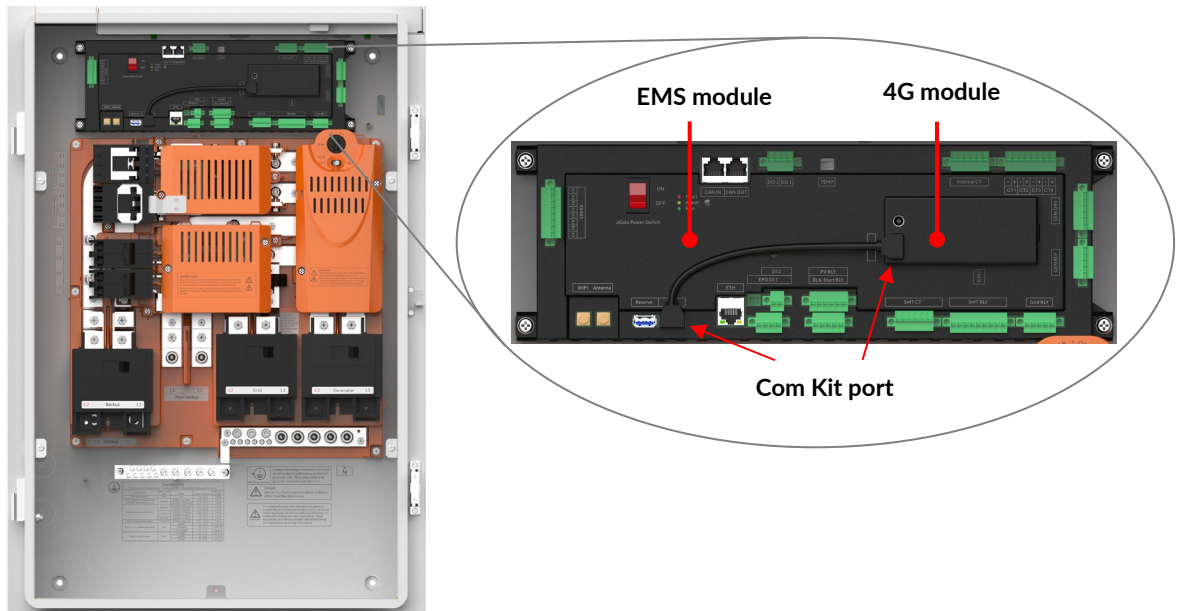

WARNING: Only use the cable supplied with the equipment. The aGate cannot be activated if this step is not completed.

Establish communications between the FranklinWH App and the aGate

- 1) Connect the mobile device to the aGate hotspot network to establish a local communications connection between the FranklinWH App and the aGate using the following account and password:

Account: AP_last 9 digits of serial number

Password: last 12 digits of serial number



NOTE: The account and password can be modified through the FranklinWH App.

- 2) Connect the aGate to the home internet network for remote access.
 - a) **Method 1 (Recommended):** Connect the aGate to the home internet using a communications cable (Not provided).
 To ensure the reliability of remote communications, it is recommended to connect the home network cable with internet connection to the **ETH** port of EMS module.

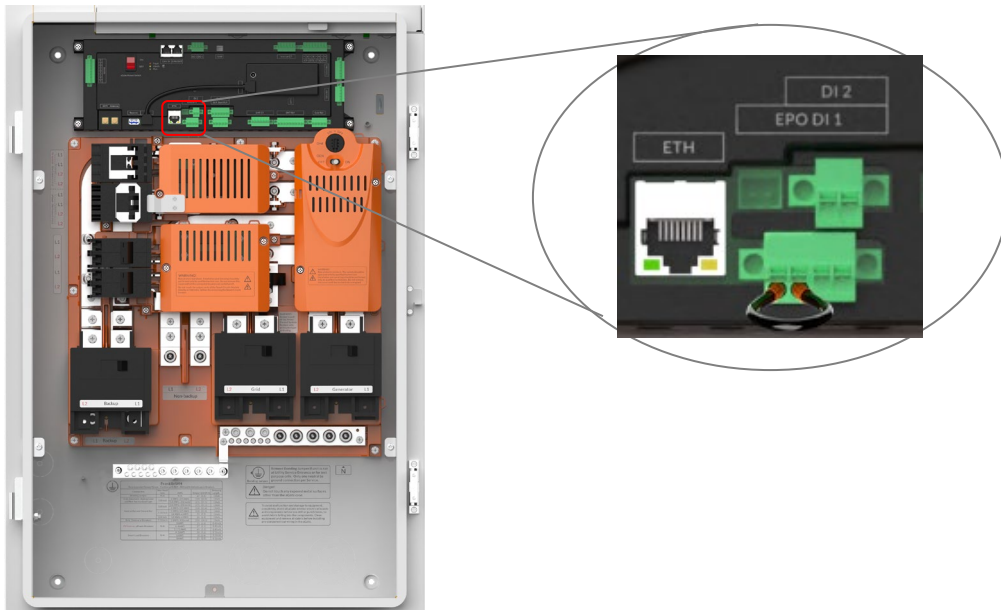

WARNING: The cable from the home network may only be connected to the ETH port.



The communications cable needs to be made on site using a crimping tool, a ready-made network cable should not be used because it may prevent the aGate internal cover from closing. Test with a network cable tester to ensure that the cable contact is error-free.

Communications cable preparation

- i. Remove the insulation jacket from the cable.
- ii. Fan the wires in the order of 568B (See wiring scheme diagram).
- iii. Insert the wires into the connector.
- iv. Crimp the connector using a crimping tool and then the cable is ready.
- v. Test with a network cable tester to ensure that the communications cable contact is error-free. Before testing the cable, ensure that both ends of the cable are disconnected from the FranklinWH system.

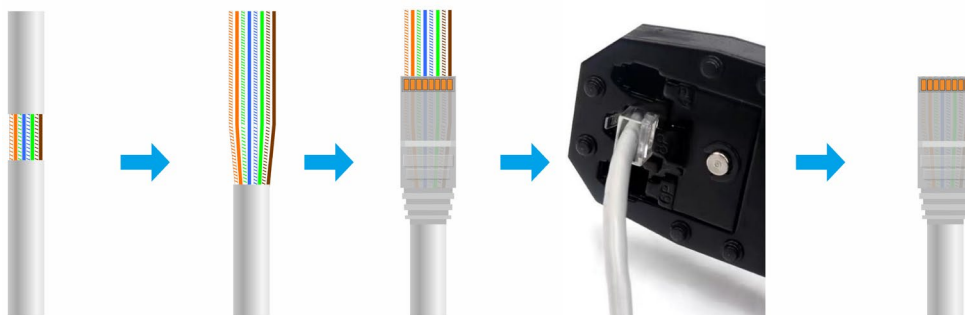

Wiring scheme

The communications cable wiring must conform to the 568B standard sequence.

Pin 1: white/orange

Pin 2: solid orange

Pin 3: white/green

Pin 4: solid blue

Pin 5: white/blue

Pin 6: solid green

Pin 7: white/brown

Pin 8: solid brown

RJ-45 Pin	1	2	3	4	5	6	7	8
Pair	2	2	3	1	1	3	4	4

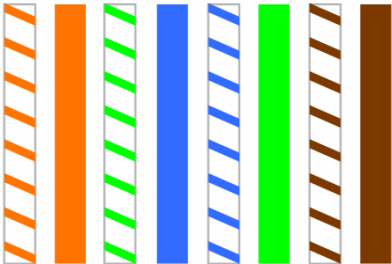
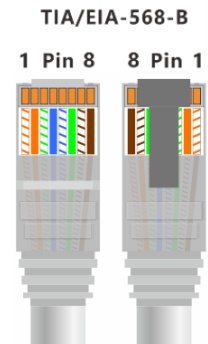
b) Method 2: Connect via Wifi

The Wifi connection between the aGate and home wireless network should be done during commissioning. Please refer to the *FranklinWH Commissioning Guide*.

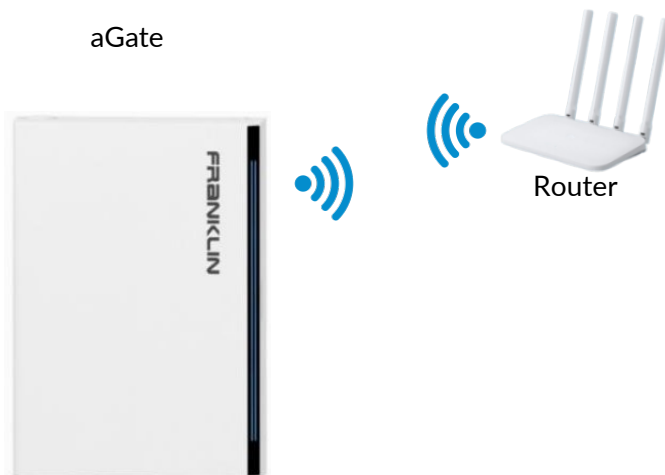

c) Method 3: Connect via 4G network (only as backup)

A SIM card is pre-installed on the wireless module. When you choose 4G network connection, make sure that there is a good 4G LTE signal in the local area.

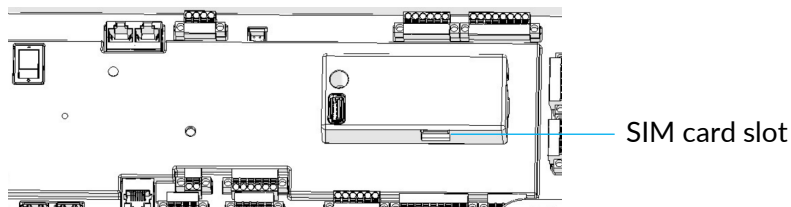

Establish communications between the aGate and the aPower



NOTE: It is recommended to install the communications cable in the conduit to avoid accidental damage and equipment failure. If the network cable and the power cable share the same conduit, use a shielded network cable (RJ45 cable end with metal connector).

Before connecting the communications cable, use a network cable tester to ensure that the cable contact is error-free.

The distance between the aGate and the first/single aPower must be ≤ 164 ft (50 m).

a) Communications connection between the aGate and a single aPower

Use a minimum CAT5 cable to connect the aGate **CAN OUT** port to the aPower **CAN IN** port in the wiring compartment.

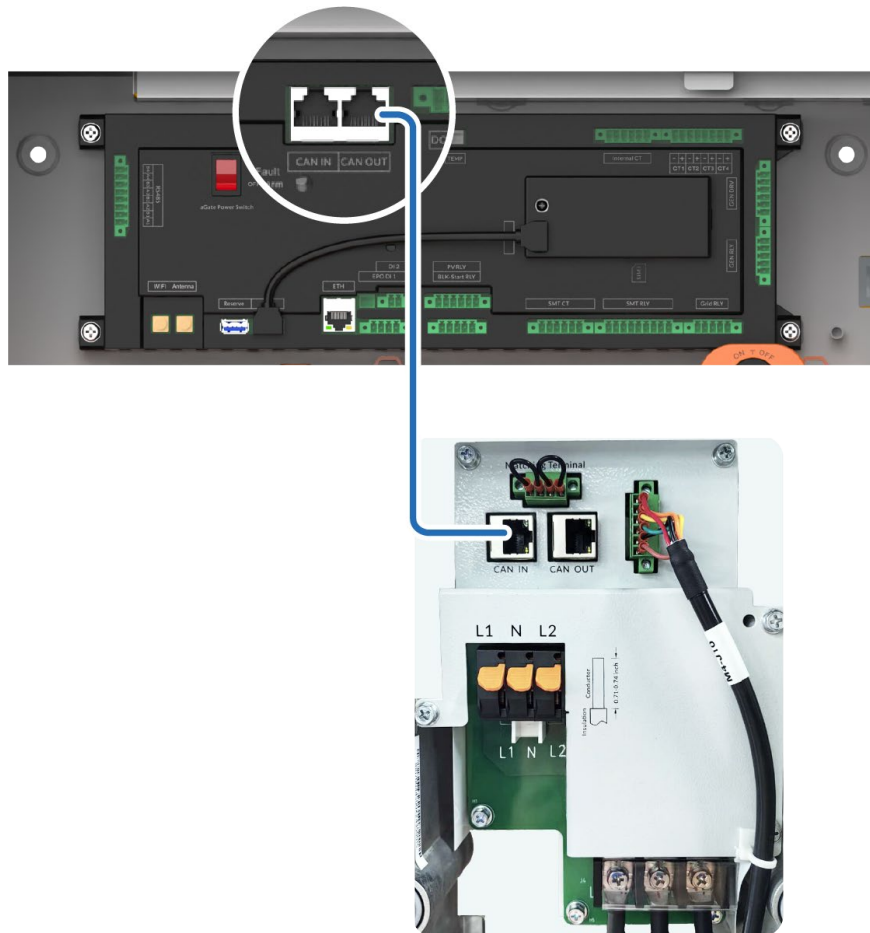

b) Communications connection between the aGate and multiple aPowers

Use a minimum CAT5 network cable to connect the aGate **CAN OUT** port to the **CAN IN** port of the first aPower, and connect the **CAN OUT** port of the first aPower to the **CAN IN** port of the second aPower, etc.

Remove the matching terminal jumpers from all aPower units except for the jumper in the **last** aPower.

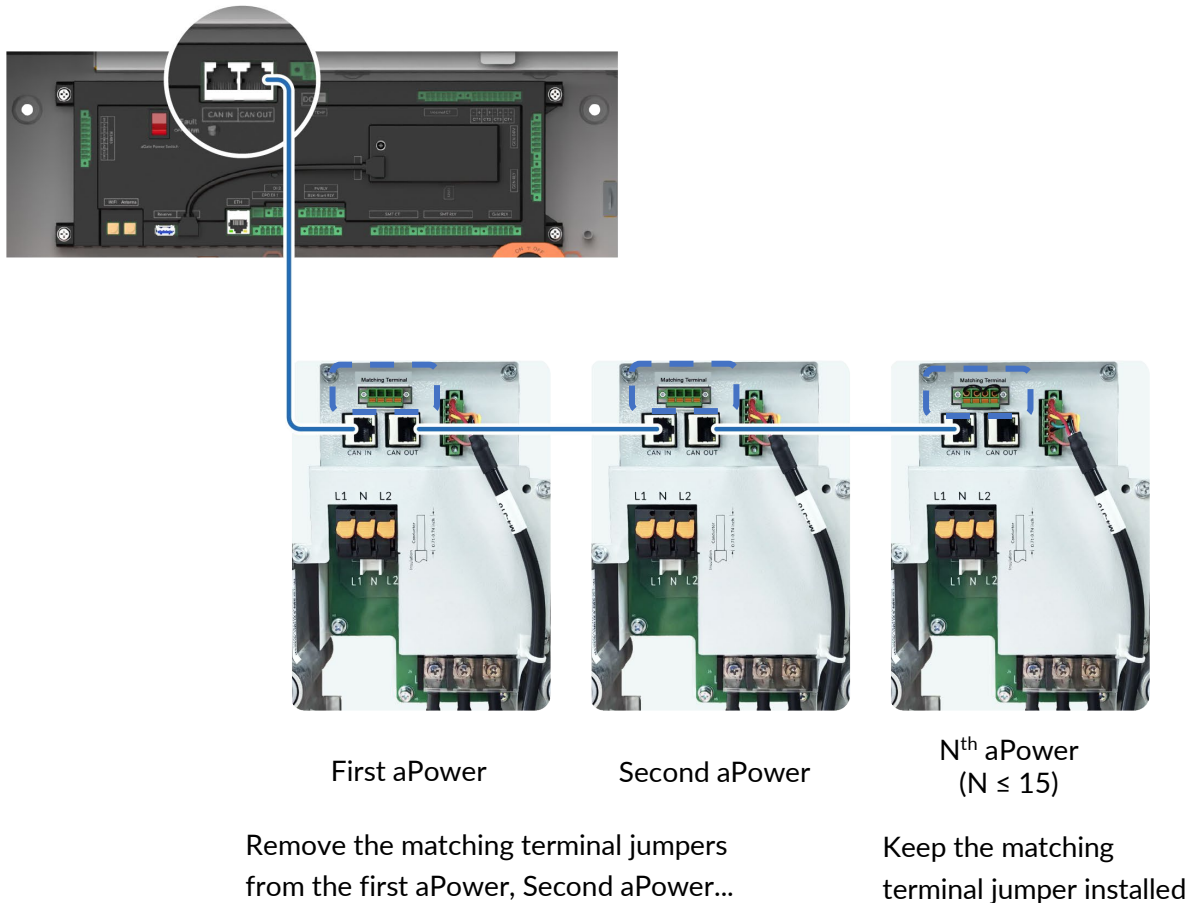

If the distance between the aGate and the first/single aPower exceeds 164 ft (50 m), please contact engineering@franklinwh.com for guidance.

Electrical Wiring



NOTE: The wiring of breakers should follow the specific breaker instructions. The power sources must be connected to the aGate at the corresponding ports.

The cable conductor size and current capacity rating are listed in the NFPA 70, Article 310.

Conductors, relied upon for the protective grounding and bonding system, will be sized to handle the intended fault currents and, if insulated, the insulation will be green or green with yellow stripes.





Grounding conductors are sized following NFPA 70 Article 250.122 of or C22.1 Rule 10-810.

A field wiring terminal or lead shall be rated for the connection of a conductor or conductors having a minimum carrying capacity rating of 125% of the rating of the unit.

The distance between the end of the connection point of a field-installed wire and the wall of the enclosure toward which the wire is to be directed, shall be following NFPA 70 Table 312.6 (A) or (B).

Please be sure to apply antioxidants to any aluminum cable stripped surfaces.

Cables selection will consider metal compatibility. Please refer to Figure F.1 in Appendix F for the UL9540 standard.

	<p>DANGER: Please follow the Local Precedence rule. Remote control does not mean that the local circuits are safe. Please decide whether your circuit is safe based only on a circuit test.</p>
	<p>DANGER: The power cables should be wired in a sequence of the load side, the backup power supply side, and the non-backup power supply side. If the other end of a cable cannot be wired at the same time, a warning sign Out of Operation, Do NOT Turn On should be hung.</p>
	<p>DANGER: aGate and aPower units do not have any indoor-level lightning protection. Customers should configure lightning protection equipment where the grid power runs into the house.</p>
	<p>DANGER: Electrical connections require that the wires are connected in the correct order, where L1 and L2 cannot be misconnected. Incorrect wiring may cause equipment damage or even personal injury or death.</p>

Connect the PV inverter to the aGate

When connecting a PV inverter to the aGate, the PV breaker is the only interface to be used. Do not connect the PV inverter to any other port.

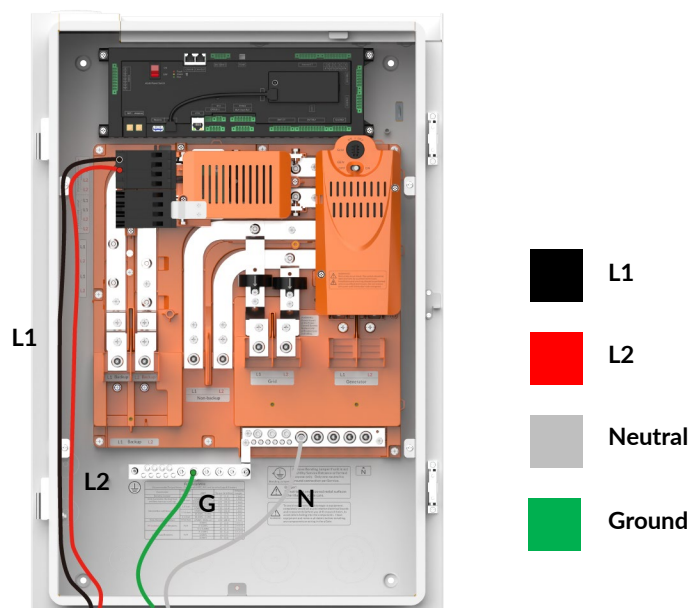

Connect the backup panel to the aGate

Connect the backup panel conductors to the aGate terminals. Refer to [Wiring Requirements](#) for recommended cables.

After installation of the backup panel breaker, L1 and L2 will swap sides for connections (L2 is located to the left while L1 is to the right).

Without a backup panel breaker

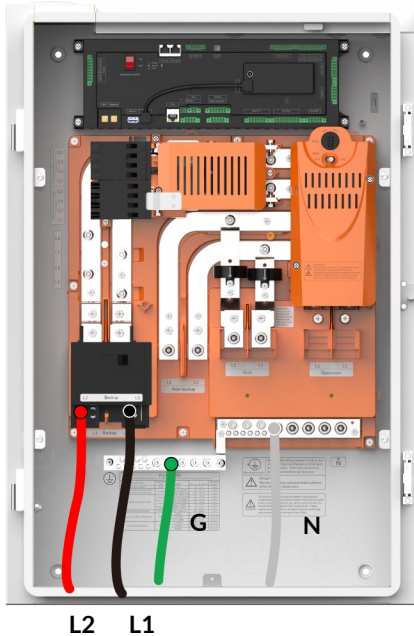

With a backup panel breaker

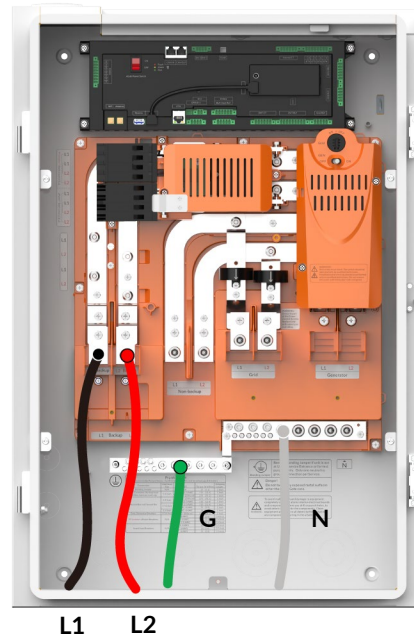

Connect the grid supply to the aGate

Connect the grid supply conductors to the aGate terminals. Refer to [Wiring Requirements](#) for recommended cables.

After installation of the grid breaker, L1 and L2 will swap sides for connections (L2 is located to the left while L1 is to the right).

Without a grid breaker

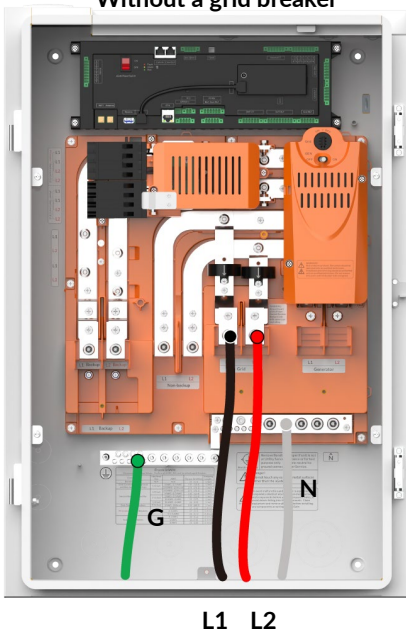

With a grid breaker

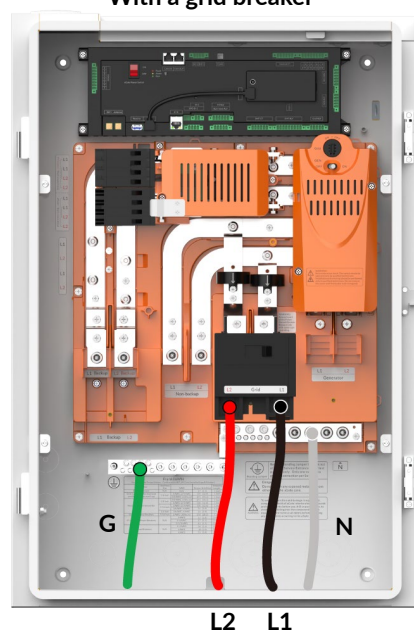

According to NFPA 70 250 Grounding and Bonding Part V, when installed as service equipment, Ensure the panel's main breaker is appropriately labeled as "SERVICE DISCONNECT," the neutral and ground should be bonded together, as shown in the figure below.

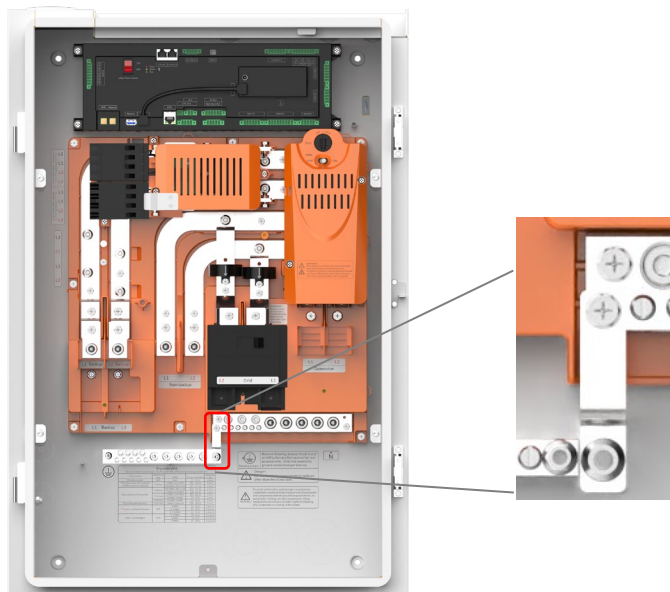

The Neutral-Ground Bonding Jumper must only be removed if not installed as Service Equipment, or for test purposes.

A torque wrench with 11/32" hex sockets will be needed to remove or install the bonding jumpers.

For installation, the required torque is 26.55 lb·in. (3 N·m).



WARNING: To ensure safe operation in Backup Mode, the aGate must have a local ground connection, such as through a ground rod or ground electrode. The connection of the ground rod must comply with local codes and regulations.

Connect the aPower(s) to the aGate

NOTE

Use **ONLY** copper conductors with a temperature rating of 194° F (90° C) for aPower connections.

aPower Breakers Options

Select the appropriate aPower breaker based on the desired power output.

Nominal Output Power (AC)	Maximum Apparent Power	Maximum Continuous Current
2.5 kW	2.9 kVA	12 A
5 kW	5.8 kVA	24 A
6.7 kW	7.7 kVA	32 A
8.4 kW	9.6 kVA	40 A
10 kW	11.5 kVA	48 A

NOTE: When the system operates on-grid, the aPower 2 output is set to the value configured during commissioning. In off-grid mode, the aPower 2 output defaults to 10 kW.

Connecting one aPower to the aGate

Follow these guidelines when wiring one aPower to the aGate:

- Use one (1) pair of wires for a single aPower connection to the aPower 2-pole breaker on the aGate.
- Select a power cable with a wire gauge ranging from 16 AWG to 6 AWG, based on the aPower rated power set in the FranklinWH App.
- The recommended strip length for the cable connected to the AC terminal of the aPower is 0.71 to 0.74 in. (18 to 19 mm).
- To connect the other end of the cable to the breaker, determine the cable stripping length based on the breaker configured.

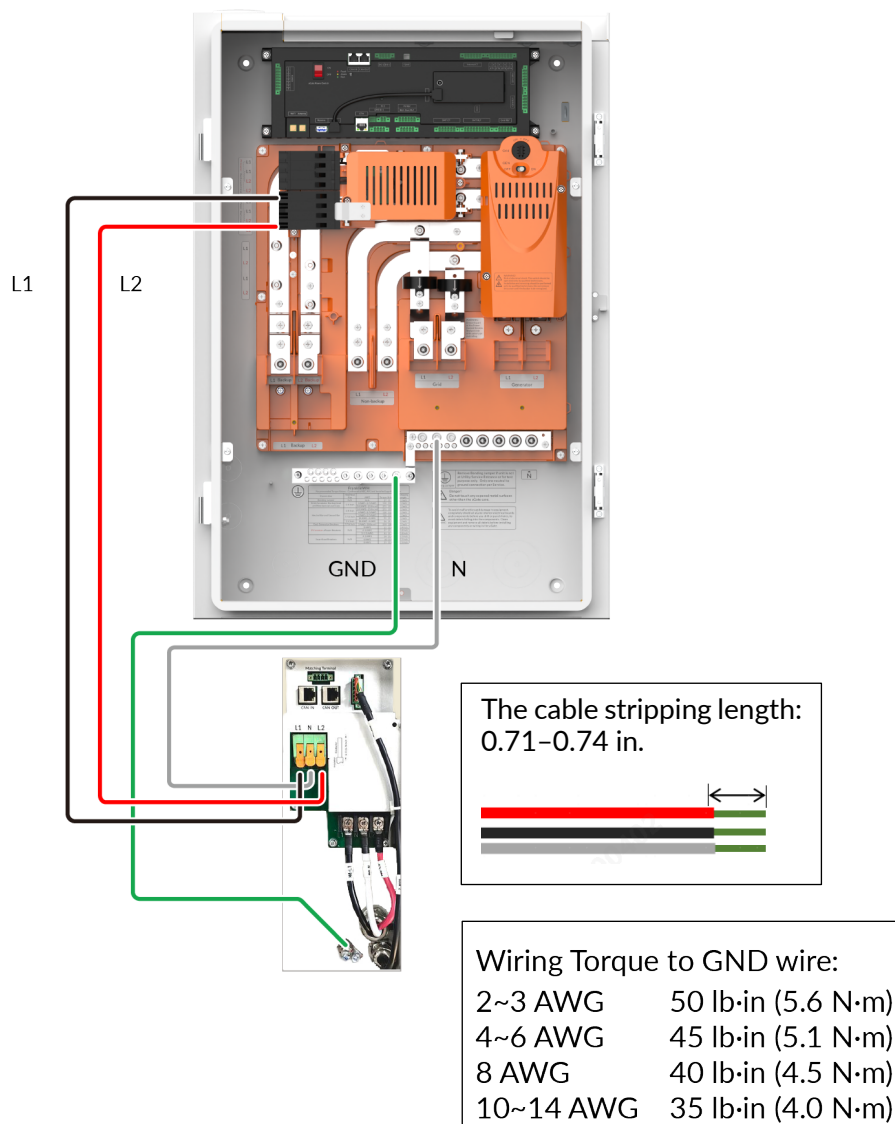

Connecting two aPowers to the aGate

Follow these guidelines when wiring two aPowers to the aGate:

- Use two pairs of wires for the two aPower connections to the aPower quadplex breaker on the aGate. Refer to [Table 5 aPower Breaker](#) for compatible quadplex breaker.
- Select a power cable with a wire gauge ranging from 16 AWG to 6 AWG, based on the aPower rated power set in the FranklinWH App.
- The recommended strip length for the cable connected to the AC terminal of the aPower is 0.71 to 0.74 in. (18 to 19 mm).
- Refer to [Wiring Requirements](#) for cable stripping length to connect the other end of the cable to the G bar, N bar, and breaker.

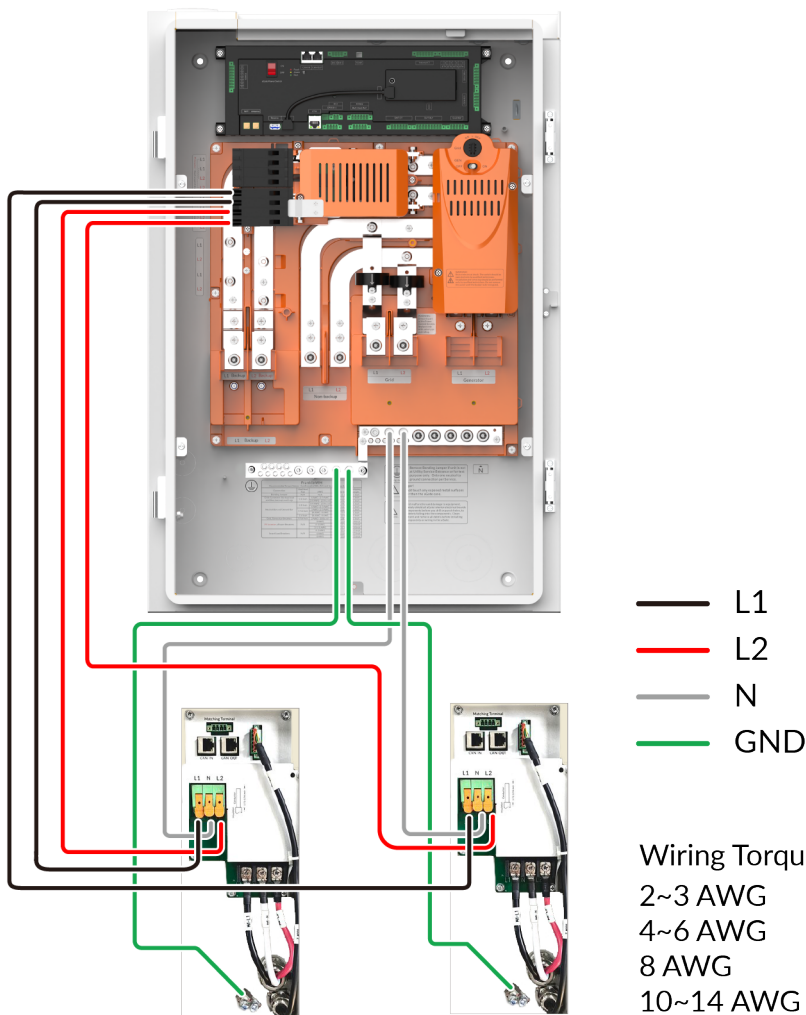

Connecting more than two aPowers to the aGate (consult FranklinWH for technical support)

When connecting more than two aPowers, a combiner box will be needed. Connect the combiner box to the backup load terminals on the aGate.

Use the optional backup expansion lug kit for aPower input. This connection does not support backup circuit breaker installation.

Refer to the parameters printed on the inner panel of the aGate for the maximum current of the circuit breakers.

Each aPower is connected to the combiner box via a dedicated circuit breaker. Refer to [Table 7 Breakers in a combiner box](#) for the compatible breakers.

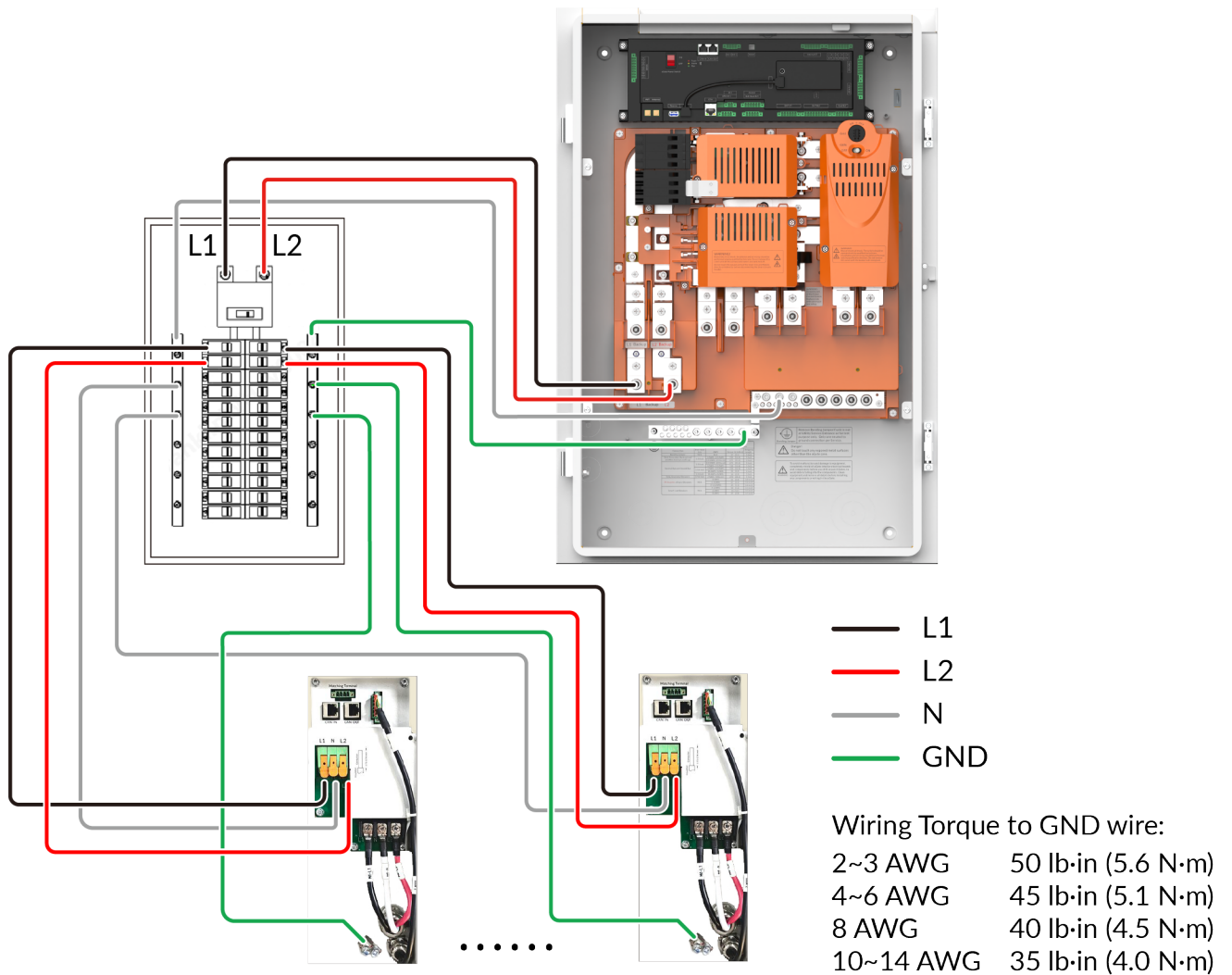

Wiring Requirements

Terminal Name	Wire Gauge	Tool	Strip Length	Torque
Single-lug Terminal	4 AWG-250 MCM CU/AL	8 mm hex wrench 5/8-18 UNF Hex head screw:	1 in	3/0 AWG-250 MCM, 275LB-IN 4 AWG-2/0 AWG, 110 LB-IN
N bar	4 AWG-250 MCM CU/AL	8 mm hex wrench 5/8-18 UNF Hex head screw:	1 in	3/0 AWG-250 MCM, 275 LB-IN 4 AWG-2/0 AWG, 110 LB-IN
	14 AWG-2/0 AWG CU/AL	5 mm hex wrench 7/16-20 UNF Hex head screw	1 in.	3 AWG-2/0 AWG, 110 LB-IN 14 AWG-4 AWG, 35 LB-IN
	14 AWG-4 AWG CU/AL	Straight screwdriver 1/4-28 UNF	0.6 in.	14 AWG-4 AWG, 26 LB-IN
G bar	14 AWG-2/0 AWG CU/AL	5 mm hex wrench Hex head screw: 7/16-20 UNF	0.8 in.	3 AWG-2/0 AWG, 110 LB-IN 14 AWG-4 AWG 35 LB-IN
	14 AWG-4 AWG CU/AL	Straight screwdriver 1/4-28 UNF	0.4 in./0.8 in.	14 AWG-4 AWG, 26 LB-IN

NOTE

For aPower connection, use ONLY copper conductors, rated to a minimum of 194° F (90° C).

For aGate connection, use copper or aluminum wire, rated to a minimum of 167° F (75° C)

Install an Optional Emergency Power Off (EPO) Switch

When an emergency situation occurs, such as a fire or a smoking battery, the user may manually press the EPO switch button to power off the entire system, when it is safe to do so. The external EPO switch is optional. Consult your local AHJ or Utility before installation.

NOTE



If the external EPO switch is not connected to the FranklinWH system, keep the factory default configuration i.e., the factory-installed EPO terminal block connector on the EMS is short connected as shown in the right figure.



Guidelines for EPO Switch Selection and Installation:

- Must be labeled as "Emergency Stop Button," "Emergency Stop Device," "Emergency Stop Unit."
- Must have an ON/OFF switch that maintains its position after being manually set to either status.
- Must have a clear indication of the ON/OFF positions.
- Must be outdoor rated (NEMA 3R or higher).
- The maximum length of the voltage wire between the EPO switch and the aGate should not exceed 150 feet (45.3 m).
- The EPO shall have a rated voltage of 5 V or higher.

Installation Procedures

- 1) Make sure all breakers in the aGate and all switches connected to the aGate are disconnected. Wait at least five (5) minutes. Use a multimeter to check that the AC voltages at both input and output terminals of the aGate are zero (0), to ensure that all electrical equipment has been disconnected from the aGate.



WARNING: When the EPO button is pressed, the EPO is in the OFF state. That means the EPO function has been activated to protect the system. At this time, the aPower(s) will be shut off and relays inside aGate (including the supply relay, the generator relay, the Smart Circuits relay, and the PV relay) will be disconnected. It also disconnects the utility grid and the backup port on aGate. Auxiliary power remains ON.

Do not use the EPO for maintenance operations or in any condition other than an emergency.

- 2) Remove the factory-installed jumper from the EPO terminal block connector on the EMS module.

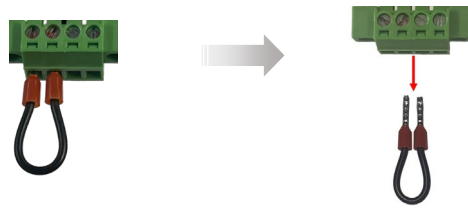

- 3) Using wire rated at 16-24 AWG, connect pins 3 and 4 (labeled EPO) to the C (common) and NC (normal close) of an external EPO switch.

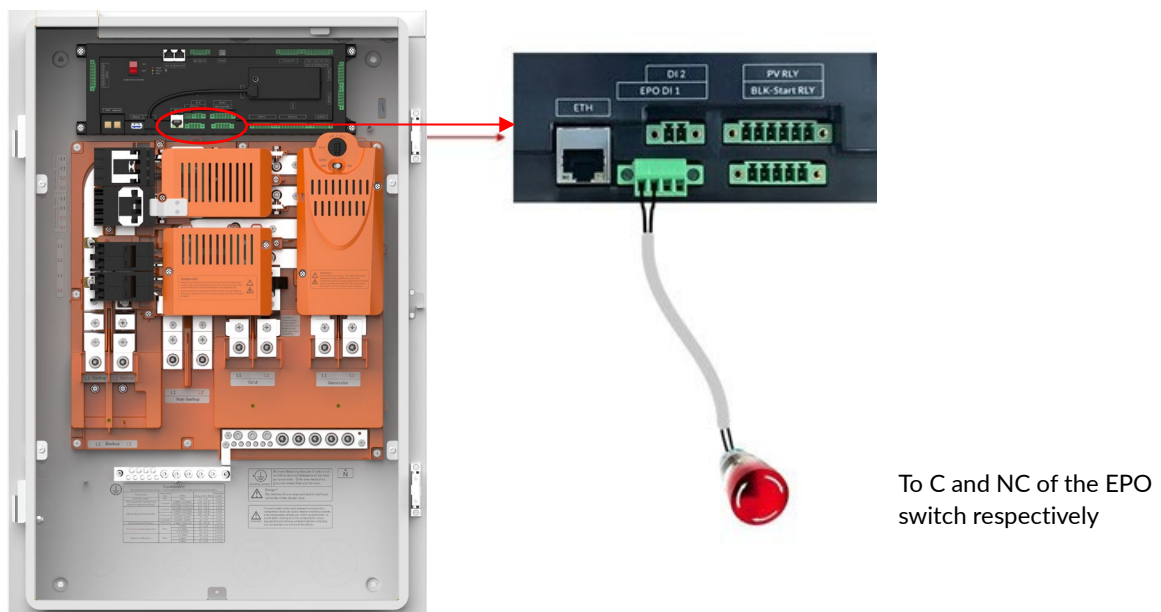

- 4) Attach the “Note of EPO” label from the aGate accessory bag to the aGate inner panel.

Complete Installation

Install the aPower Exterior Cover

1. Insert the communications cable and grounding wire into their respective ports. Insert the power cables L1, N, and L2 into the AC terminals in a left-to-right order.

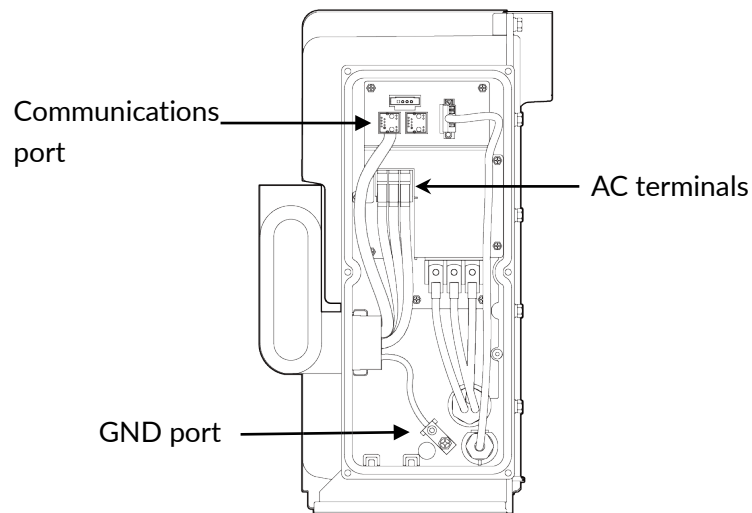

2. Tighten the six captive crews and firmly secure the wiring compartment cover to the aPower.

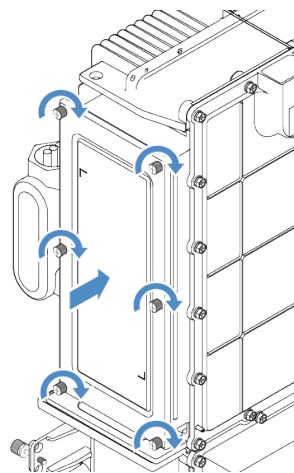

WARNING: Make sure the stripping length of cable is appropriate, the conductors are firmly secured, and there are no exposed conductors.

- Use diagonal pliers to remove the knockouts from the exterior cover.

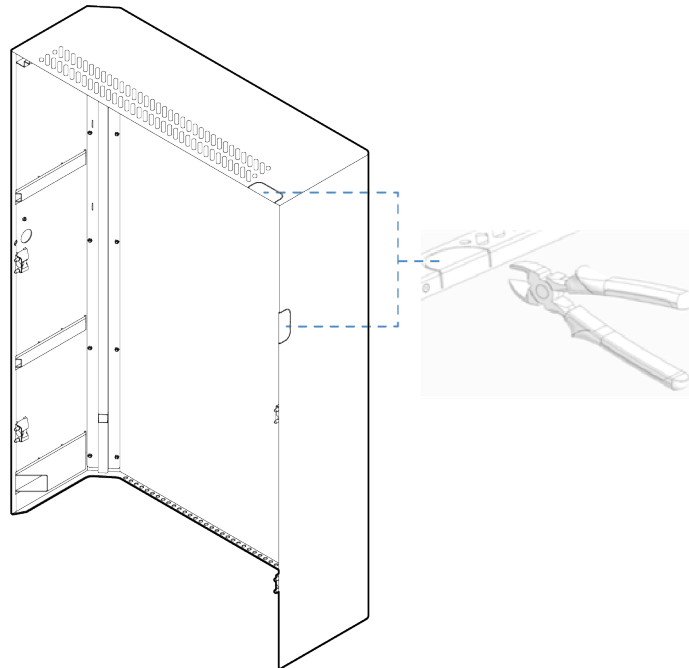

- Connect the LED light power cables on the exterior cover and on the aPower chassis.

Partially attach the exterior cover to the chassis. Align the arrows on both connectors of the LED light power cables and insert the male connector into the female one. Rotate the connectors clockwise until they are firmly secured with the two white markers aligned.

NOTE



Two installers will be needed to complete the LED light power cables connection.

Make sure this connection achieves a NEMA 6P protection rating.

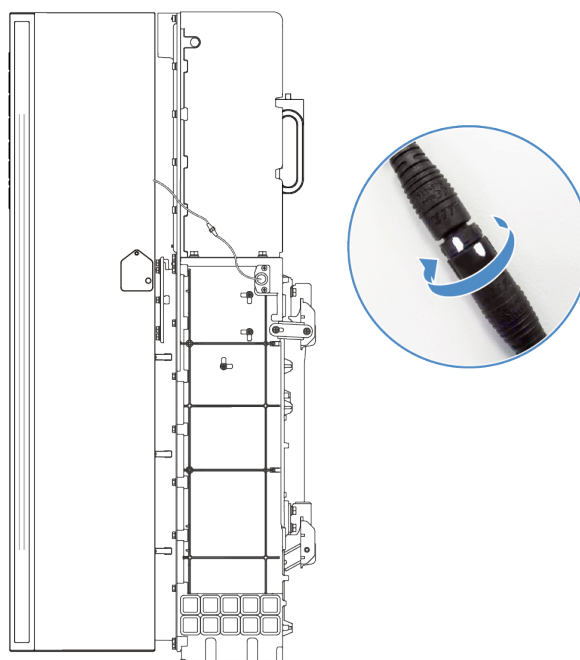

5. Align and insert eight locating pins on the exterior cover into the corresponding holes on the rear left and right side of the chassis. Securely fasten the two captive screws.

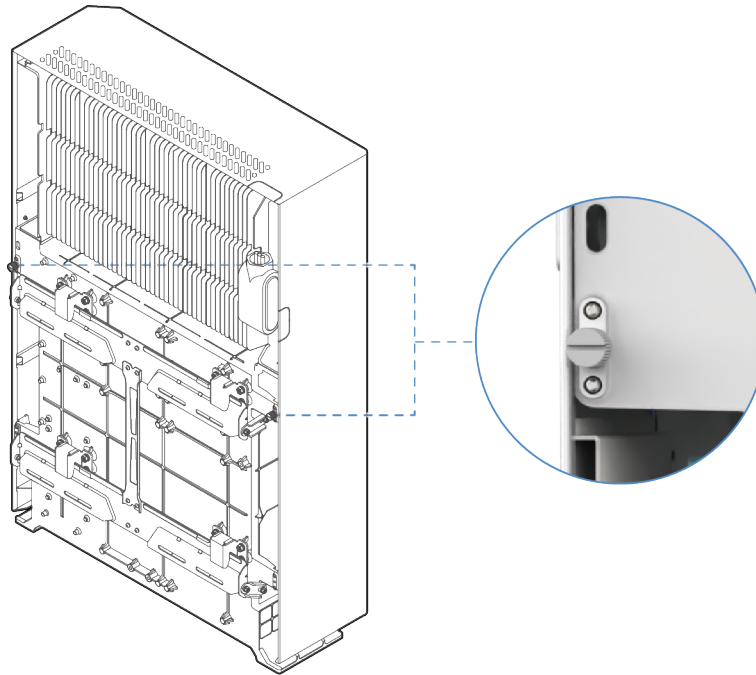

Re-Install the aGate Door and Inner Panel

- 1) Install the inner panel and fasten it by tightening the four original M5 x 12 combination bolts to 2.21 lb·ft (3.0 N·m).
- 2) Remove the knockouts on the inner panel for the installed breakers.

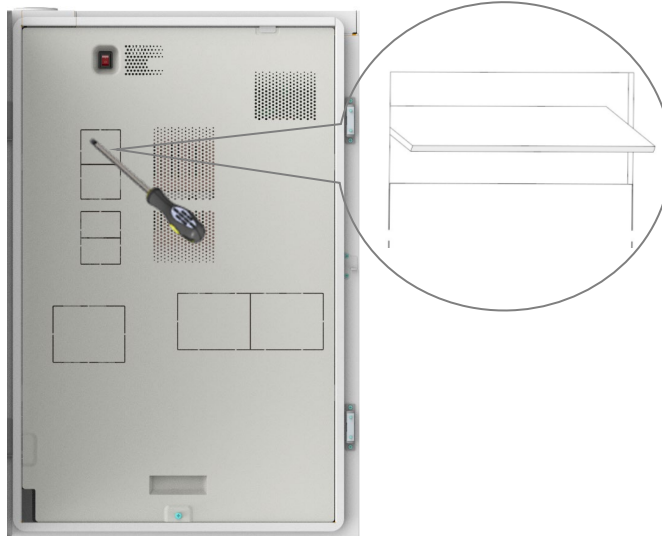

- 3) Attach the labels from the literature kit (bag with labels and accessories) onto the aGate inner panel to indicate circuit locations.
- 4) Re-install the aGate door.
- 5) Close the aGate door. Press the upper and lower latches to ensure that the door is tightly closed without any gaps.



WARNING: Gaps between the door and enclosure may cause water to leak into the aGate.

Commissioning and Acceptance

The FranklinWH system installation is complete. For the commissioning and acceptance process, please refer to the *FranklinWH Commissioning Guide*.

Appendix 1: Allowed Breakers

Table 1 Grid Breakers

Grid Breaker			
S/N	Model	Current	Description
1	CSR2100	100 A	Eaton#Circuit Breaker; 2-Pole, 25 kAIC, 100 A/240 V
2	CSR2125N	125 A	Eaton#Circuit Breaker; 2-Pole, 25 kAIC, 125 A/240 V
3	CSR2150N	150 A	Eaton#Circuit Breaker; 2-Pole, 25 kAIC, 150 A/240 V
4	CSR2175N	175 A	Eaton#Circuit Breaker; 2-Pole, 25 kAIC, 175 A/240 V
5	CSR2200N	200 A	Eaton#Circuit Breaker; 2-Pole, 25 kAIC, 200 A/240 V
6	BW2100	100 A	Eaton#Circuit Breaker; 2-Pole, 10 kAIC, 100 A/240 V
7	BW2125	125 A	Eaton#Circuit Breaker; 2-Pole, 10 kAIC, 125 A/240 V
8	BW2150	150 A	Eaton#Circuit Breaker; 2-Pole, 10 kAIC, 150 A/240 V
9	BW2175	175 A	Eaton#Circuit Breaker; 2-Pole, 10 kAIC, 175 A/240 V
10	BW2200	200 A	Eaton#Circuit Breaker; 2-Pole, 10 kAIC, 200 A/240 V
11	BWH2100N	100 A	Eaton#Circuit Breaker; 2-Pole, 25 kAIC, 100 A/240 V
12	BWH2125N	125 A	Eaton#Circuit Breaker; 2-Pole, 25 kAIC, 125 A/240 V
13	BWH2150N	150 A	Eaton#Circuit Breaker; 2-Pole, 25 kAIC, 150 A/240 V
14	BWH2175N	175 A	Eaton#Circuit Breaker; 2-Pole, 25 kAIC, 175 A/240 V
15	BWH2200N	200 A	Eaton#Circuit Breaker; 2-Pole, 25 kAIC, 200 A/240 V

***NOTE:** When opting for a 25 kAIC grid breaker, it is necessary to select a backup power circuit breaker with a matching 25 kAIC rating as well.

Table 2 Backup Port Breakers

Backup Port Breaker			
S/N	Model	Current	Description
1	CSR2100	100 A	Eaton#Circuit Breaker; 2-Pole, 25 kAIC, 100 A/240 V
2	CSR2125N	125 A	Eaton#Circuit Breaker; 2-Pole, 25 kAIC, 125 A/240 V
3	CSR2150N	150 A	Eaton#Circuit Breaker; 2-Pole, 25 kAIC, 150 A/240 V
4	CSR2175N	175 A	Eaton#Circuit Breaker; 2-Pole, 25 kAIC, 175 A/240 V
5	CSR2200N	200 A	Eaton#Circuit Breaker; 2-Pole, 25 kAIC, 200 A/240 V
6	BW2100	100 A	Eaton#Circuit Breaker; 2-Pole, 10 kAIC, 100 A/240 V
7	BW2125	125 A	Eaton#Circuit Breaker; 2-Pole, 10 kAIC, 125 A/240 V
8	BW2150	150 A	Eaton#Circuit Breaker; 2-Pole, 10 kAIC, 150 A/240 V
9	BW2175	175 A	Eaton#Circuit Breaker; 2-Pole, 10 kAIC, 175 A/240 V
10	BW2200	200 A	Eaton#Circuit Breaker; 2-Pole, 10 kAIC, 200 A/240 V
11	BWH2100N	100 A	Eaton#Circuit Breaker; 2-Pole, 25 kAIC, 100 A/240 V
12	BWH2125N	125 A	Eaton#Circuit Breaker; 2-Pole, 25 kAIC, 125 A/240 V
13	BWH2150N	150 A	Eaton#Circuit Breaker; 2-Pole, 25 kAIC, 150 A/240 V
14	BWH2175N	175 A	Eaton#Circuit Breaker; 2-Pole, 25 kAIC, 175 A/240 V
15	BWH2200N	200 A	Eaton#Circuit Breaker; 2-Pole, 25 kAIC, 200 A/240 V

NOTE: When opting for a 25 kAIC Backup circuit breaker, it is necessary to select a grid circuit breaker with a matching 25 kAIC rating. If choose 10 kAIC Grid breaker, for 22KA short-circuit rating, the marked current rating shall be followed with the words "Max - see main circuit breaker rating."

Table 3 Generator Breakers

Generator Breaker			
S/N	Model	Current	Description
1	CSR2100	100 A	Eaton#Circuit Breaker; 2-Pole, 25 kAIC, 100 A/240 V
2	CSR2125N	125 A	Eaton#Circuit Breaker; 2-Pole, 25 kAIC, 125 A/240 V
3	CSR2150N	150 A	Eaton#Circuit Breaker; 2-Pole, 25 kAIC, 150 A/240 V
4	CSR2175N	175 A	Eaton#Circuit Breaker; 2-Pole, 25 kAIC, 175 A/240 V
5	CSR2200N	200 A	Eaton#Circuit Breaker; 2-Pole, 25 kAIC, 200 A/240 V
6	BW2100	100 A	Eaton#Circuit Breaker; 2-Pole, 10 kAIC, 100 A/240 V
7	BW2125	125 A	Eaton#Circuit Breaker; 2-Pole, 10 kAIC, 125 A/240 V
8	BW2150	150 A	Eaton#Circuit Breaker; 2-Pole, 10 kAIC, 150 A/240 V
9	BW2175	175 A	Eaton#Circuit Breaker; 2-Pole, 10 kAIC, 175 A/240 V
10	BW2200	200 A	Eaton#Circuit Breaker; 2-Pole, 10 kAIC, 200 A/240 V
11	BWH2100N	100 A	Eaton#Circuit Breaker; 2-Pole, 25 kAIC, 100 A/240 V
12	BWH2125N	125 A	Eaton#Circuit Breaker; 2-Pole, 25 kAIC, 125 A/240 V
13	BWH2150N	150 A	Eaton#Circuit Breaker; 2-Pole, 25 kAIC, 150 A/240 V
14	BWH2175N	175 A	Eaton#Circuit Breaker; 2-Pole, 25 kAIC, 175 A/240 V
15	BWH2200N	200 A	Eaton#Circuit Breaker; 2-Pole, 25 kAIC, 200 A/240 V

*NOTE: The generator breaker may be installed outside the aGate depending on the site condition.

Table 4 PV Breakers

PV Breaker				
S/N	Description	Manufacturer Model 1	Manufacturer Model 2	Manufacturer Model 3
1	2-Pole, 10 kAIC, 30 A/240 V	Eaton# BR230	Siemens# Q230	Schneider# HOM230
2	2-Pole, 10 kAIC, 40 A/240 V	Eaton# BR240	Siemens# Q240	Schneider# HOM240
3	2-Pole, 10 kAIC, 50 A/240 V	Eaton# BR250	Siemens# Q250	Schneider# HOM250
4	2-Pole, 10 kAIC, 60 A/240 V	Eaton# BR260	Siemens# Q260	Schneider# HOM260
5	2-Pole, 10 kAIC, 70 A/240 V	Eaton# BR270	Siemens# Q270	Schneider# HOM270
6	2-Pole, 10 kAIC, 80 A/240 V	Eaton# BR280	Siemens# Q280	Schneider# HOM280
7	2-Pole, 22 kAIC, 30 A/240 V	Eaton# BRH230	Siemens# Q230H	N/A
8	2-Pole, 22 kAIC, 40 A/240 V	Eaton# BRH240	Siemens# Q240H	N/A
9	2-Pole, 22 kAIC, 50 A/240 V	Eaton# BRH250	Siemens# Q250H	N/A
10	2-Pole, 22 kAIC, 60 A/240 V	Eaton# BRH260	Siemens# Q260H	N/A
11	2-Pole, 22 kAIC, 70 A/240 V	Eaton# BRH270	Siemens# Q270H	N/A
12	2-Pole, 22 kAIC, 80 A/240 V	Eaton# BRH280	Siemens# Q280H	N/A
13	2-Pole, 10 kAIC, 2X15A/240 V	Eaton# BQC215215	Siemens# Q21515CT2	Schneider# HOMT215215
14	2-Pole, 10 kAIC, 2X20A/240 V	Eaton# BQC220220	Siemens# Q22020CT2	Schneider# HOMT220220
15	2-Pole, 10 kAIC, 2X30A/240 V	Eaton# BQC230230	Siemens# Q23030CT2	Schneider# HOMT230230
16	2-Pole, 10 kAIC, 2X40A/240 V	Eaton# BQC240240	Siemens# Q24040CT2	N/A
17	2-Pole, 10 kAIC, 2X15A/240 V	Eaton# BQ215215	N/A	N/A
18	2-Pole, 10 kAIC, 2X20A/240 V	Eaton# BQ220220	N/A	N/A
19	2-Pole, 10 kAIC, 2X30A/240 V	Eaton# BQ230230	N/A	N/A
20	2-Pole, 10 kAIC, 2X40A/240 V	Eaton# BQ240240	N/A	N/A

Table 5 aPower Breakers

aPower Breaker				
S/N	Description	Manufacturer Model 1	Manufacturer Model 2	Manufacturer Model 3
1	2-Pole, 10 kAIC, 30 A/240 V	Eaton# BR230	Siemens# Q230	Schneider# HOM230
2	2-Pole, 10 kAIC, 40 A/240 V	Eaton# BR240	Siemens# Q240	Schneider# HOM240
3	2-Pole, 10 kAIC, 50 A/240 V	Eaton# BR250	Siemens# Q250	Schneider# HOM250
4	2-Pole, 10 kAIC, 60 A/240 V	Eaton# BR260	Siemens# Q260	Schneider# HOM260
5	2-Pole, 10 kAIC, 70 A/240 V	Eaton# BR270	Siemens# Q270	Schneider# HOM270
6	2-Pole, 10 kAIC, 80 A/240 V	Eaton# BR280	Siemens# Q280	Schneider# HOM280
7	2-Pole, 10 kAIC, 90 A/240 V	Eaton# BR290	Siemens# Q290	Schneider# HOM290
8	2-Pole, 10 kAIC, 100 A/240 V	Eaton# BR2100	Siemens# Q2100	Schneider# HOM2100
9	2-Pole, 22 kAIC, 30 A/240 V	Eaton# BRH230	Siemens# Q230H	N/A
10	2-Pole, 22 kAIC, 40 A/240 V	Eaton# BRH240	Siemens# Q240H	N/A
11	2-Pole, 22 kAIC, 50 A/240 V	Eaton# BRH250	Siemens# Q250H	N/A
12	2-Pole, 22 kAIC, 60 A/240 V	Eaton# BRH260	Siemens# Q260H	N/A
13	2-Pole, 22 kAIC, 70 A/240 V	Eaton# BRH270	Siemens# Q270H	N/A
14	2-Pole, 22 kAIC, 80 A/240 V	Eaton# BRH280	Siemens# Q280H	N/A
15	2-Pole, 22 kAIC, 90 A/240 V	Eaton# BRH290	Siemens# Q290H	N/A
16	2-Pole, 22 kAIC, 100 A/240 V	Eaton# BRH2100	Siemens# Q2100H	N/A
17	2-Pole, 10 kAIC, 2X30A/240 V	Eaton# BQC230230	Siemens# Q23030CT2	Schneider# HOMT230230
18	2-Pole, 10 kAIC, 2X40A/240 V	Eaton# BQC240240	Siemens# Q24040CT2	N/A
19	2-Pole, 10 kAIC, 2X50A/240 V	Eaton# BQC250250	N/A	N/A
20	2-Pole, 10 kAIC, 2X30A/240 V	Eaton# BQ230230	N/A	N/A
21	2-Pole, 10 kAIC, 2X40A/240 V	Eaton# BQ240240	N/A	N/A
22	2-Pole, 10 kAIC, 2X50A/240 V	Eaton# BQ250250	N/A	N/A

***NOTE:** If two aPowers are to be installed, a quadplex circuit breaker from 17-22 is recommended.

Table 6 Smart Circuit Breakers

Breaker for Smart Circuit 1 and 2 (1-Pole)			
S/N	Model	Current	Description
1	CH120	20 A	Eaton#Circuit Breaker; 1-Pole, 10 kAIC, 20 A/240 V
2	CH130	30 A	Eaton#Circuit Breaker; 1-Pole, 10 kAIC, 30 A/240 V
3	CH135	35 A	Eaton#Circuit Breaker; 1-Pole, 10 kAIC, 35 A/240 V
4	CH140	40 A	Eaton#Circuit Breaker; 1-Pole, 10 kAIC, 40 A/240 V
5	CH145	45 A	Eaton#Circuit Breaker; 1-Pole, 10 kAIC, 45 A/240 V
6	CH150	50 A	Eaton#Circuit Breaker; 1-Pole, 10 kAIC, 50 A/240 V
7	CHF130	30 A	Eaton#Circuit Breaker; 1-Pole, 10 kAIC, 30 A/240 V
8	CHF135	35 A	Eaton#Circuit Breaker; 1-Pole, 10 kAIC, 35 A/240 V
9	CHF140	40 A	Eaton#Circuit Breaker; 1-Pole, 10 kAIC, 40 A/240 V
10	CHF145	45 A	Eaton#Circuit Breaker; 1-Pole, 10 kAIC, 45 A/240 V
11	CHF150	50 A	Eaton # Circuit Breaker; 1-Pole, 10 kAIC, 50 A/240 V
Breaker for Smart Circuit 1 + Circuit 2 (2-Pole)			
S/N	Model	Current	Description
1	CH230	30 A	Eaton#Circuit Breaker; 2-Pole, 10 kAIC, 30 A/240 V
2	CH235	35 A	Eaton#Circuit Breaker; 2-Pole, 10 kAIC, 35 A/240 V
3	CH240	40 A	Eaton#Circuit Breaker; 2-Pole, 10 kAIC, 40 A/240 V
4	CH245	45 A	Eaton#Circuit Breaker; 2-Pole, 10 kAIC, 45 A/240 V
5	CH250	50 A	Eaton#Circuit Breaker; 2-Pole, 10 kAIC, 50 A/240 V
6	CHF230	30 A	Eaton#Circuit Breaker; 2-Pole, 10 kAIC, 30 A/240 V
7	CHF235	35 A	Eaton#Circuit Breaker; 2-Pole, 10 kAIC, 35 A/240 V
8	CHF240	40 A	Eaton#Circuit Breaker; 2-Pole, 10 kAIC, 40 A/240 V
9	CHF245	45 A	Eaton#Circuit Breaker; 2-Pole, 10 kAIC, 45 A/240 V
10	CHF250	50 A	Eaton#Circuit Breaker; 2-Pole, 10 kAIC, 50 A/240 V

Breaker for Smart Circuit 3			
S/N	Model	Current	Description
1	CH230	30 A	Eaton#Circuit Breaker; 2-Pole, 10 kAIC, 30 A/240 V
2	CH235	35 A	Eaton#Circuit Breaker; 2-Pole, 10 kAIC, 35 A/240 V
3	CH240	40 A	Eaton#Circuit Breaker; 2-Pole, 10 kAIC, 40 A/240 V
4	CH245	45 A	Eaton#Circuit Breaker; 2-Pole, 10 kAIC, 45 A/240 V
5	CH250	50 A	Eaton#Circuit Breaker; 2-Pole, 10 kAIC, 50 A/240 V
6	CH260	60 A	Eaton#Circuit Breaker; 2-Pole, 10 kAIC, 60 A/240 V
7	CH270	70 A	Eaton#Circuit Breaker; 2-Pole, 10 kAIC, 70 A/240 V
8	CH280	80 A	Eaton#Circuit Breaker; 2-Pole, 10 kAIC, 80 A/240 V
9	CHF230	30 A	Eaton#Circuit Breaker; 2-Pole, 10 kAIC, 30 A/240 V
10	CHF235	35 A	Eaton#Circuit Breaker; 2-Pole, 10 kAIC, 35 A/240 V
11	CHF240	40 A	Eaton#Circuit Breaker; 2-Pole, 10 kAIC, 40 A/240 V
12	CHF245	45 A	Eaton#Circuit Breaker; 2-Pole, 10 kAIC, 45 A/240 V
13	CHF250	50 A	Eaton#Circuit Breaker; 2-Pole, 10 kAIC, 50 A/240 V

Table 7 Breakers in a combiner box

S/N	aPower Rated Power	Recommended Breaker
1	2.9 kVA (2.5 kW)	15 A
2	5.8 kVA (5.0 kW)	30 A
3	7.7 kVA (6.7 kW)	40 A
4	9.6 kVA (8.4 kW)	50 A
5	11.5 kVA (10.0 kW)	60 A

***NOTE:** If homeowners need capacity expansion, configure the circuit breaker and cables based on the maximum output of 10kW from aPower.

Appendix 2: Datasheet

aPower

BAT DC Terminal, Bi-Directional	
Nominal voltage (V)	51.2 V
Max. charging current (A)	166 A
Max. charging power (kW)	8 kW
Max. discharging current (A)	201 A
Max. discharging power (kW)	10 kW
AC Terminal, Bi-Directional	
Nominal AC voltage (V)	120/208 V, 120/240 V, (L1, L2, N)
Nominal AC frequency (Hz)	50 Hz / 60 Hz
Nominal AC output current (A)	42 A
Nominal AC output power (kW), (L-N)	5.0 kW
Nominal AC output power (kW), (L-L)	10.0 kW
Max. Continuous AC output current (A)	48 A
Max. Continuous AC output power (kVA), (L-N)	5.75 kVA
Max. Continuous AC output power (kVA), (L-L)	11.5 kVA
Nominal AC input current (A)	34 A
Max. Continuous AC input current (A)	38 A
Nominal AC input power (kW), (L-L)	8.0 kW
Max. Continuous AC input power (kVA), (L-L)	9.2 kVA
Power Factor Range	0.87 leading to 0.87 lagging
Max. overcurrent protection (amps), circuit breaker ratings	60 A
Others	
Operation temperature range	-4° F to 122° F (-20° C to +50° C)
Storage temperature range	≤24 hours: -22° F to 140° F (-30° C to +60° C) ≤ 9 months: -4° F to 113° F (-20° C to +45° C) ≤ 12 months: -4° F to 95° F (-20° C to +35° C)
Ingress protection	IP67 (Battery Pack & Inverter) IP56 (Wiring)
Operating Humidity (RH)	Up to 100 %, non-condensing
Storage Humidity (RH)	Up to 100 %, non-condensing
Certificate	UL9540, UL1973, UL9540A, UN38.3, UL1741, UL1741 SB, UL1741 PCS, IEEE1547, IEEE1547.1, FCC Part 15 Class B, CSA C22.2 No. 107.1
Dimensions (H x W x D)	45.19 in. x 29.5 in. x 11.83 in. (1148 mm x 750 mm x 300.5 mm)
Weight	357 lbs. (162 kg)

aGate

(1) Grid Terminal, Bi-Directional	
Nominal AC Grid voltage (V)	120/208 V; 120/240 V, (L1, L2, N)
Nominal AC Grid frequency (Hz)	60 Hz
Nominal AC input current (A)	160 A
Nominal AC input power (kW)	38.4 kW
Max. Continuous AC input power (kVA)	38.4 kVA
Max. overcurrent protection (amps), circuit breaker ratings	200 A
(2) Generator Terminal	
Nominal AC input voltage (V)	120/240 V, (L1, L2, N)
Nominal AC input frequency (Hz)	60 Hz
Nominal AC input current (A)	160 A
Nominal AC input power (kW)	38.4 kW
Max. Continuous AC input current (A)	160 A
Max. Continuous AC input power (kVA)	38.4 kVA
Max. overcurrent protection (amps), circuit breaker ratings	200 A
(3) Non-Backup Output Terminal	
Nominal AC output voltage (V)	120/208 V; 120/240 V, (L1, L2, N)
Nominal AC output frequency (Hz)	60 Hz
Nominal AC output current (A)	160 A
Nominal AC output power (kW)	38.4 kW
Max. Continuous AC output current (A)	160 A
Max. Continuous AC output power (kVA)	38.4 kVA
(4) Backup Output Terminal	
Nominal AC output voltage (V)	120/208 V; 120/240 V, (L1, L2, N)
Nominal AC output frequency (Hz)	60 Hz
Nominal AC output current (A)	160 A
Nominal AC output power (kW)	38.4 kW
Max. Continuous AC output current (A)	160 A
Max. Continuous AC output power (kVA)	38.4 kVA
(5) PV inverter's Input Terminal	
Nominal AC input voltage (V)	120/208 V; 120/240 V, (L1, L2, N)
Nominal AC input frequency (Hz)	60 Hz
Nominal AC input current (A)	64 A
Nominal AC input power (kW)	15.36 kW
Max. overcurrent protection (amps), circuit breaker ratings	80 A
(6) aPower AC Terminal, Bi-Directional	
Nominal AC voltage (V)	120/208 V; 120/240 V, (L1, L2, N)
Nominal AC frequency (Hz)	60 Hz
Nominal AC current (A)	80 A
Max. overcurrent protection (amps), circuit breaker ratings	100 A

(7) AC Output Terminal, Smart Circuit 1, 2	
Nominal AC output voltage (V)	120/208 V; 120/240 V, (L1, L2, N)
Nominal AC output frequency (Hz)	60 Hz
Nominal AC output current (A)	40 A
Nominal AC output power (kW) (L-L)	9.6 kW
Max. Continuous AC output current (A) (L-L)	40 A
Max. Continuous AC output power (kW) (L-L)	9.6 kW
Nominal AC output power (kW) (L-N)	4.8 kW
Max. Continuous AC output current (A) (L-N)	40 A
Max. Continuous AC output power (kW) (L-N)	4.8 kW
Max. output overcurrent protection (amps), circuit breaker ratings	50 A
(8) AC Output Terminal, Smart Circuit 3	
Nominal AC output voltage (V)	120/208 V; 240 V, (L1, L2)
Nominal AC output frequency (Hz)	60 Hz
Nominal AC output current (A)	64 A
Nominal AC output power (kW) (L-L)	15.36 kW
Max. Continuous AC output current (A) (L-L)	64 A
Max. Continuous AC output power (kVA) (L-L)	15.36 kVA
Nominal AC output power (kW) (L-N)	7.68 kW
Max. Continuous AC output current (A) (L-N)	64 A
Max. Continuous AC output power (kVA) (L-N)	7.68 kVA
Max. output overcurrent protection (amps), circuit breaker ratings	80 A
(9) Busbar	
Max. AC current (A)	280 A
Others	
Operation temperature range	-4° F to 122° F (-20° C to +50° C)
Storage temperature range	-22° F to 140° F (-30° C to +60° C)
Enclosure Type	Type 3R
Operating Humidity (RH)	Up to 100 %, non-condensing
Storage Humidity (RH)	Up to 100 %, non-condensing
Weight	38.6 lbs. (17.5kg)
Dimensions (W*H*D, inch)	21.7 in. x 31.5 in. x 6.3 in. (550 mm x 800 mm x 160 mm)
Ingress protection	IP44
Certificate	UL1741, UL67, UL869A, UL916, FCC Part 15 Class B