

Planning an Enphase Energy System

Contents

- Overview 3**
- Enphase Energy System overview 3**
 - Product overview 4**
 - Product generation and interoperability 8**
- Design an Enphase Energy System 9**
 - Regulatory background 9**
 - National Electrical Code 9
 - Features to improve design and installation flexibility 9
- Economic use cases 11**
- System profiles 12**
- System sizing 12**
 - Load analysis 12**
 - Microinverter array and IQ Battery sizing 13**
 - Relationship between microinverter and IQ Battery sizing in grid-forming systems 13
 - Generator sizing 15
 - Storage system sizing 19
- Component list for different system configurations 22**
 - Component list for Solar Only or Battery Only system configurations 22**
 - With IQ Battery 5P and/or IQ System Controller 3/3G 22
 - With IQ Battery 3T/10T and/or IQ System Controller 2 25
 - Component list for Solar + Battery system configurations 28**
 - With IQ Battery 5P and/or IQ System Controller 3/3G 28
 - With IQ Battery 3T/10T and/or IQ System Controller 2 32
- Grid-tied (without backup) system configurations 34**
 - Solar Only 34**
 - With IQ Combiner 5/5C 35
 - With IQ Combiner 4/4C 36
 - Battery Only 36**
 - With IQ Battery 5P 36
 - With IQ Battery 3T/10T 38
 - Solar + Battery 40**
 - With IQ Battery 5P 41

With IQ Battery 3T/10T	45
Grid-forming (with backup) system configurations	47
Solar Only	47
Sunlight Backup (partial home backup)	47
Battery Only	50
Whole home backup	50
Partial home backup	54
Solar + Battery	58
Whole home backup	58
Partial home backup	73
Control wiring	88
Installation guidelines	88
Common Control wiring sequences	89
Preparing for the wiring	90
Step 1: Getting the right cable length	90
Step 2: Stripping the cables that have been cut	91
Step 3: Connecting cables to headers	91
Electrical installation considerations	91
Voltage regulation considerations	91
Rapid shutdown of Enphase Energy System	92
Abbreviations	92
Appendix A	93
Other supported configurations	93
Grid-tied configurations	93
Appendix B	96
Appendix C	97
Split Enphase Systems on a single site with IQ6/IQ7/IQ8 or M Series Microinverters	97
Split systems with additional Consumption CTs	99
Split systems without additional Consumption CTs	102
Split system without additional Consumption CTs where batteries prioritize backup loads only	106
Revision history	108

Overview

This paper contains information for site surveyors and design engineers to analyze a site and plan the design, installation, and support of home energy backup systems using the Enphase Energy System. This is not a guide for installation and operation. This paper supplements the information in the data sheets, quick install guides, and product manuals. This document's diagrams and information are demonstrative of system configurations and installations. They may not, however, include all additional state and local codes, standards, and other Authorities Having Jurisdiction (AHJs) applicable to a site.



NOTE: IQ Battery Oversubscription feature is not supported currently. A software upgrade will soon make this function available.



NOTE: IQ8MC-72-M-US, IQ8AC-72-M-US, and IQ8HC-72-M-US are not available currently.

Enphase Energy System overview

All Enphase Energy Systems fall into one of the following groups depending on the energy sources used in a system.

1. Solar Only
2. Battery
3. Solar + Battery

The system can also be divided into grid-tied and grid-forming systems based on its ability to form a microgrid. An IQ System Controller will be installed in a grid-forming system.

Grid-forming systems can be categorized as a whole home or partial home backup systems.

Whole home backup: When the power grid fails, the Enphase Energy System will switch all electrical circuits to backup power. The system must have sufficient backup power and energy capacity to support all the loads in a home.

Partial home backup: The home loads are segregated into backed-up and non-backed-up loads. The backup load panel is set up to power essential loads. When the power goes out, the Enphase Energy System powers the backup electrical panel while leaving the main load panel unpowered.

The Enphase Energy System supports four following use cases that are described in the following table:

Table 1: EES use cases

Energy sources at the site	Configuration	Description
Solar Only, Solar + Battery, or Battery Only	Grid-tied	- The system does not provide any backup. It saves money by supplying power to home loads, storing energy generated for later use, or exporting excess energy back to the grid when permitted. ¹
Solar Only	Partial home backup (Sunlight Backup)	- When the sun shines, the system offers backup for up to four 240 V loads or eight 120 V vital loads.

¹ Export from Enphase IQ Battery is generally not permitted, except when requested by utilities via grid services programs.

Energy sources at the site	Configuration	Description
		<ul style="list-style-type: none"> - Only IQ8 Series Microinverters support this configuration.
Solar + Battery or Battery Only	Partial home backup	<ul style="list-style-type: none"> - The system provides essential load backup during the day or night. - Load Control is advised for any backup load that exceeds storage power capacity.
Solar + Battery or Battery Only	Whole home backup	<ul style="list-style-type: none"> - The system provides backup for the whole home during the day or night. - Storage capacity is chosen to be sufficient to meet NEC 710.15(a) on its own. - Load Control is advised for better energy management and resilience.

Product overview

- **IQ8 Series Microinverters and accessories:** The Enphase Energy System is fully compatible with IQ8 Series Microinverters.
- **IQ6/IQ7 Series Microinverters and accessories.** Ensemble technology is fully compatible with IQ7 and IQ6 Series Microinverters and makes retrofit upgrades as simple as new installations.
- **Enphase M Series Microinverters and accessories.** Ensemble technology is compatible with Enphase M215 and M250 Microinverters, making retrofit upgrades simple.



NOTE: The Ensemble upgrade is only compatible with M215 and M250 Series Microinverters. Other legacy microinverters are not supported.



WARNING: IQ8 Series Microinverters are not backward compatible with IQ6, IQ7, or M Series Microinverters. The Enphase Energy System does not support mixing IQ6/IQ7 Series Microinverters with IQ8 Series Microinverters or M Series Microinverters.



NOTE: M215 and M250 Series Microinverters are the only legacy microinverters compatible with the Enphase Energy System. Other legacy microinverters are incompatible.



WARNING: The Enphase Energy System does not support mixing M Series Microinverters with IQ8 Series Microinverters or IQ6/IQ7 Series Microinverters. Use an Envoy S Metered for M Series Microinverters.



WARNING: The Enphase Energy System does not support any configurations with third-party PV inverters.

- **IQ Gateway** is a communications gateway that can communicate with IQ Series Microinverters, IQ Batteries, and the IQ System Controller 2/3/3G. It collects system performance information and transmits it over the internet to Enphase Cloud. An IQ Gateway is required for Enphase Energy Systems with IQ Series Microinverters. Note that the IQ Gateway is included in an Enphase IQ Combiner. For retrofit sites, an IQ Gateway may already be present.



NOTE: A stand-alone IQ Gateway (without the IQ Combiner) would need a COMMS-KIT-02 installed for wired communication with the IQ System Controller 3/3G and/or the IQ Battery 5P.



WARNING: IQ Gateway will not communicate with M Series Microinverters. Use an Envoy S Metered for M Series Microinverters.



WARNING: M Series Microinverters require Envoy S Metered gateway to work with IQ Batteries. Envoy S Metered is not IEEE 1547:2018 compliant. If the utility insists on IEEE 1547:2018 compliance, microinverter replacement with IQ7 or IQ8 Series will be required.

- **Envoy S Metered** is a communications gateway with M Series Microinverters, IQ Batteries, and the IQ System Controller 2/3/3G. It collects system performance information and transmits it over the internet to Enphase Cloud. An Envoy S Metered is required for every Enphase Energy System with M Series Microinverters.



NOTE: An Envoy S Metered would need a COMMS-KIT-02 installed for wired communication with the IQ System Controller 3/3G and/or the IQ Battery 5P.



WARNING: Legacy Gateway/EMU SKUs (ENV-120-01, ENV-120-02, IEMU-03, IEMU-01, or IEMU02) will not work with an Enphase Energy System. You must replace these legacy SKUs with an Envoy S Metered during the Enphase Energy System installation.

An Envoy S Metered would need a COMMS-KIT-02 installed for wired communication with the IQ System Controller 3/3G and/or the IQ Battery 5P.

- **Enphase System Shutdown Switch** is the only rapid shutdown switch per 2020 NEC 690.12 for an IQ8 grid-agnostic system. This switch is bundled together with the IQ System Controller 2/3/3G.



NOTE: Enphase System Shutdown switch is not needed in an Enphase Energy System with IQ6/7 Series or M Series Microinverters. Enphase System Shutdown switch is only NEC and UL 1741 PV RSE complaint for IQ8 grid-forming systems. It must not be installed or placarded as the rapid shutdown initiator for IQ6/7 or M Series Microinverters.

- **IQ Combiner 4/4C** consolidates interconnection equipment into a single enclosure and streamlines PV and storage installations by providing a consistent, pre-wired solution for residential applications. IQ Combiner 4/4C includes Enphase **IQ Gateway with the latest software to support IQ8 Microinverters**. Install the new Communication Kit with IQ Combiner 4/4C to enable wireless communication with IQ System Controller 2 and IQ Battery 3/3T/10/10T. IQ Combiner 4/4C also supports hold-down kits on all four PV circuits. IQ Combiner 4C ships with Enphase Mobile Connect, cellular modem CELLMODEM-M1-06-SP-05, pre-installed, while IQ Combiner 4 ships without the cell modem.



NOTE: A stand-alone IQ Gateway or IQ Combiners other than IQ Combiner5/5C require a COMMS-KIT-02 installed for wired communication with the IQ System Controller 3/3G and/or the IQ Battery 5P.

- **IQ Combiner 5/5C** consolidates interconnection equipment into a single enclosure and streamlines PV and storage installations by providing a consistent, pre-wired solution for residential applications. It offers up to four 2-pole 20 A input circuits and an Eaton BR series busbar assembly. IQ Combiner 5/5C supports wired communication with the IQ System Controller 3/3G and/or the IQ Battery 5P for Enphase Storage System sites. IQ Combiner 5/5C also supports hold-down kits on all four PV circuits. IQ Combiner 5C ships with Enphase Mobile Connect, cellular modem CELLMODEM-M1-06-SP-05, pre-installed, while IQ Combiner 5 ships without the cell modem.



NOTE: IQ Combiner 5/5C has wired control communication integrated into it and can operate with IQ System Controller 3/3G and IQ Battery 5P out of the box.



WARNING: When IQ System Controller 3/3G is used with IQ6, IQ7, or M Series Microinverters, the Enphase Energy System Shutdown switch (EP200G-NA-02-RSD) should not be used as a rapid shutdown initiator. The installers need to connect the RSD auxiliary contacts of IQ System Controller 3/3G using jumper wires to make the system operational. Refer to Installer memo – [Wiring the rapid shutdown switch with IQ System Controller 2](#).

- **IQ Load Controller:** Each IQ Load Controller unit can enable fine-grained, circuit-level control for two 240 V loads or four 120 V loads. Dedicated loads up to 36 A resistive/25 A inductive or branch circuits with multiple loads up to 32 A resistive/25 A inductive are supported by the IQ Load Controller.
- An **Enphase Mobile Connect** cellular modem is always required in an IQ Battery system or Sunlight Backup system to ensure the best performance of your system. The cellular modem connects to a USB port on the IQ Gateway.



NOTE: Enphase Mobile Connect cellular modem CELLMODEM-M1-06-SP-05 is preinstalled in IQ Combiner 4C/5C.

- **Current transformers** are required for the Enphase Energy System to operate correctly.
 - a) **Enphase Production CT** enables PV production monitoring. This is shipped as part of the IQ Combiner 4/4C/5/5C.
 - b) **Enphase Consumption CTs** enable home energy consumption monitoring.
 - c) **Enphase Storage CT** enables battery charging/discharging monitoring.
 - d) **Enphase Generator CTs** are needed in systems that have a generator integrated. This CT pair is connected in parallel with the Enphase Consumption CTs.
- **Enphase IQ Battery 5P** is an all-in-one AC-coupled IQ Battery system. It has a total usable energy capacity of 4.96 kWh and includes six embedded grid-forming microinverters with a 3.84 kW power rating. It provides scalable backup capability, so customers can start with 5 kWh and add IQ Batteries up to 80 kWh depending on the system design and configuration.



NOTE: IQ Battery 5P is incompatible with IQ System Controller 2 and IQ Battery 3/3T/10/10T.

- Enphase IQ System Controller 3** connects the home to grid power, the IQ Battery, and PV. It provides microgrid interconnect device (MID) functionality by automatically detecting and seamlessly transitioning the system from grid power to backup power in the event of a grid failure. It allows IQ Battery and/or an IQ6/7/8 Series Microinverter array to form an intentional island (per IEEE 1547.4 definition). It contains a neutral-forming transformer (NFT) to enable 120/240 V operation in backup mode.

IMPORTANT: IQ System Controller 3 is available in two SKUs. The SKUs have one PV distributed energy resource (DER) port and one IQ Battery DER port available. Depending on the SKU, the third DER port supports an additional 80 A storage or generator.

Table 2: IQ System Controller and SKU

Product name	SKU	3 rd DER port configuration
IQ System Controller 3	SC200D111C240US01	80 A (64 A continuous) IQ Battery
IQ System Controller 3G	SC200G111C240US01	80 A (64 A continuous) generator



WARNING: When IQ System Controller 3/3G is used with IQ6, IQ7, or M Series Microinverters, the Enphase Energy System Shutdown Switch (EP200G-NA-02-RSD) should not be used as a rapid shutdown initiator. The installers need to connect the RSD auxiliary contacts of IQ System Controller 3/3G using jumper wires to make the system operational. Refer to Installer memo – [Wiring the rapid shutdown switch with IQ System Controller 2](#).

- Enphase Communications Kit 2** enables the IQ Gateway or Envoy S Metered to communicate with IQ Battery 5P and IQ System Controller 3/3G using the Enphase CTRL cable. The kit is connected to one of the USB ports on the IQ Gateway. This product is not needed for systems using IQ Combiner 5/5C.



NOTE: Communications Kit 2 needs to be used only at sites that have standalone IQ Gateway or Envoy S Metered.



NOTE: Communications Kit 2 will not work with IQ System Controller 2 and IQ Battery 3/3T/10/10T.

- IQ Battery 3/3T/10/10T** is an all-in-one AC-coupled storage system with embedded grid-forming multimode microinverters. You can connect multiple IQ Battery **3/3T/10/10T** storage systems to maximize potential backup for homes.
- IQ System Controller 2** connects the home to grid power, the IQ Battery storage system, and PV. It provides microgrid interconnect device (MID) functionality by automatically detecting and seamlessly transitioning the system from grid power to backup power in the event of a grid failure. It allows Enphase Energy Systems to form an intentional island (per IEEE 1547.4 definition) and contains a neutral-forming transformer (NFT) to enable 120/240 V operation in backup mode.
- Communications Kit 1** enables direct communication between IQ Battery, IQ System Controller 2, and the IQ Gateway or Envoy S Metered using 2.4 GHz frequency. The kit is connected to one of the USB ports on the Envoy.

Product generation and interoperability

The Enphase Energy System is made up of three product generations. Generations 1 and 2 products use wireless communication, while Generation 3 products use wired communication. The system design and installation instructions differ depending on the product generation. In all three generations, microinverters connect with the IQ Gateway/IQ Combiner 5/5C via power line communication (PLC). Different components may not work together or support certain system features. Check the following table to see if the various system components are interoperable.

Table 3: Product generation and Interoperability

	SOLAR ONLY	SOLAR PLUS BATTERY WITHOUT BACKUP		SUNLIGHT BACKUP		SOLAR PLUS BATTERY WITH BACKUP	
	Produce solar energy only when the grid is up	Produce and save energy only when the grid is up		Produce solar energy even when the grid is down		Produce and save energy even when the grid is down	
		With IQ Battery 3T/10T	With IQ Battery 5P	With future IQ Battery 3T/10T	With future IQ Battery 5P	With IQ Battery 3T/10T	With IQ Battery 5P
Microinverters							
IQ8 Microinverter	Yes	Yes	Yes	Yes	Yes	Yes	Yes
IQ6/7 Microinverter	Yes	Yes	Yes	No	No	Yes	Yes
M Series Microinverter ¹	Yes	Yes With Envoy S Metered	Yes With Envoy S Metered	No	No	Yes With Envoy S Metered	Yes With Envoy S Metered
IQ Combiner							
IQ Combiner 5/5C	Yes	No	Yes	No	Yes	No	Yes
IQ Combiner 4/4C	Yes	Yes With COMMS-KIT-01	Yes With COMMS-KIT-02	Yes With COMMS-KIT-01	Yes With COMMS-KIT-02	Yes With COMMS-KIT-01	Yes With COMMS-KIT-02
IQ System Controller							
IQ System Controller 3/3G	N/A	N/A	N/A	No	Yes	No	Yes
IQ System Controller 2	N/A	N/A	N/A	Yes	No	Yes	No
Accessories							
IQ Load Controller	N/A	N/A	N/A	Yes Essential loads panel required	Yes Essential loads panel required	Yes	Yes
Generator Support	N/A	N/A	N/A	Yes	Yes With IQ System Controller 3G	Yes	Yes With IQ System Controller 3G

¹M series microinverters are not IEEE 1547:2018 compliant. If the site is in an area that requires IEEE 1547:2018, then upgrade to IQ8 Series Microinverters.

Design an Enphase Energy System

Regulatory background

National Electrical Code

The National Electric Code Article 705 Part II allows a microgrid system to disconnect from the utility grid and operate in island mode, forming an intentional island or microgrid that supplies backup power. The ability of an inverter to transition between interactive and island modes is called multimode. A system requires a microgrid interconnect device (MID) to disengage and reconnect to the primary power source or grid to prevent a multimode inverter from islanding while connected to the utility grid.

The IQ System Controller 3/3G includes a MID that allows the IQ8 Series Microinverters and IQ Batteries to establish an intentional island or operate in island mode when disconnected from the area’s electric power system. It also includes distributed energy resource (DER) relays for disconnecting and reconnecting the microinverter and battery storage array from both loads and the utility grid in the event of a fault condition.

The following figure shows a drawing of an AC-coupled multimode system based on 2020 NEC sections 690 and 705.

Figure 1: AC-coupled multimode system

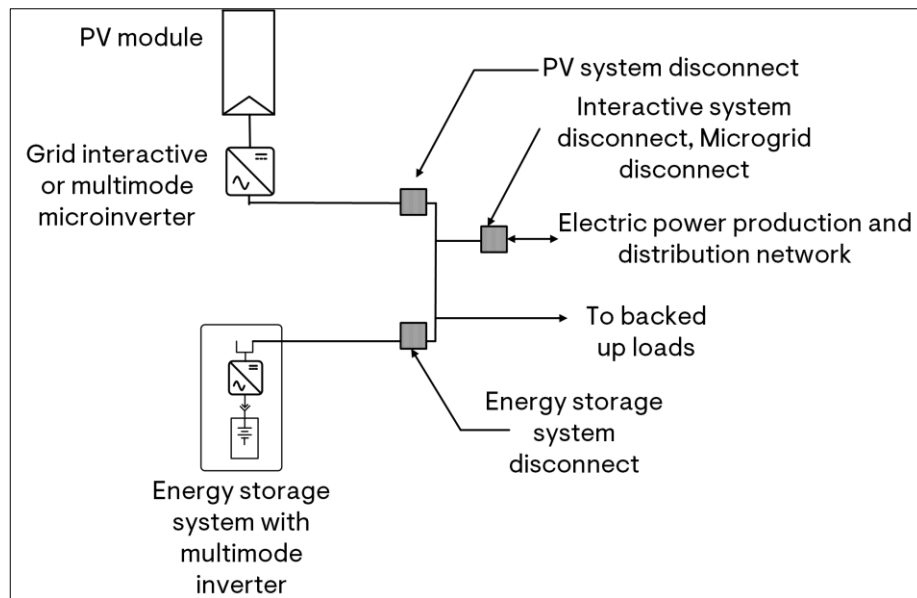

Features to improve design and installation flexibility

Rapid shutdown initiator for PV

In an Enphase system that operates only in grid-interactive mode, the PV system disconnect will initiate the PV system rapid shutdown, as specified in 2020 NEC 690.12.

The rapid shutdown initiator differs for systems that can operate in grid-forming mode, depending on the microinverter product family.

M Series, IQ6, or IQ7 Series Microinverters cannot form an intentional microgrid. The PV system disconnects, or aggregate PV breaker can accomplish this disconnect. An Enphase System Shutdown Switch is not needed in this configuration. If the jurisdiction follows NEC 2020, the IQ Combiner breaker inside the IQ System Controller can act as the rapid shutdown initiator if the IQ System Controller is installed in a readily accessible location. Otherwise, a fused disconnect must be installed as the rapid shutdown initiator. For jurisdictions that follow NEC 2017, the PV branch circuit breakers inside the IQ Combiner (or PV combiner box) can also act as the rapid shutdown initiator if the combiner is readily accessible.

For IQ8 Series Microinverters, the System Shutdown Switch must be installed, and it is the only method available to initiate rapid shutdown effectively, irrespective of whether the jurisdiction follows NEC 2017 or 2020.

ESS disconnect for IQ Battery

Enphase Energy System requires an ESS disconnecting means that can be used to disconnect the battery from other parts of the system, thereby enabling emergency shutdown of the system. Enphase System shutdown switch can be used as the ESS disconnecting means per 2023 NEC 706.15.

Power Control Systems (PCS)

Power Control Systems (PCS), as defined in NFPA 70, NEC 2020 705.13, control the output of one or more power production sources, energy storage systems (ESS), and other equipment. PCS systems limit current and loading on the busbars and conductors supplied by the power production sources and/or energy storage systems.

Enphase Energy Systems have interconnected electric power production sources such as microinverters and/or IQ Battery. The amount of power production sources that can be connected to a system is generally governed by various sections of the NEC. PCS integration allows the Enphase Energy System to install more batteries and provides features to adhere to special compliance requirements in certain jurisdictions.

PCS enables the following features in Enphase Energy System:

1. **IQ Battery Oversubscription mode:** This feature is available on systems that use IQ Battery 5P. It allows for more IQ Battery 5P to be installed against a given battery breaker by reducing the maximum continuous current rating to comply with NEC rating requirements such as 2020 NEC 705.28, thereby increasing the energy storage capacity of the site. Battery oversubscription can increase the energy capacity of the battery array by up to 200%. The system supports Battery oversubscription on up to two battery breakers. The ampacity of each breaker can be up to 80A (64 A continuous).



NOTE: This feature is not supported currently. A software upgrade will soon make this function available.

Battery oversubscription increases overload capacity relative to the new continuous current rating and is coordinated with circuit breaker trip curves.

Table 4: Overload current rating for IQ Battery 5P with PCS enabled

Overload current (as a % of original nameplate)	Time (seconds)
200%	1.5
150%	5
100%	8



NOTE: Currently, IQ Battery Oversubscription can only be enabled on systems that use IQ Battery 5P and IQ Combiner 5/5C. Enphase is evaluating the feature with IQ Gateway, which will be made available soon.

2. **Battery Import Only mode:** This PCS feature ensures the Enphase IQ Battery never exports power to the grid. This is the default mode for all IQ Batteries (IQ Battery 3T/10T, IQ Battery 5P). This feature allows the homeowner to avoid the installation of an additional Net Generation output meter (NGOM).
3. **Main Panel Upgrade (MPU) Avoidance mode:** This PCS feature limits the back feed current of the Enphase Energy System back to the grid to avoid having to upgrade the main panel. Only IQ8 Series Microinverters used with IQ Combiner 5/5C support this feature. M Series Microinverters do not support this feature.



NOTE: Currently, IQ8 MC, IQ8 AC, and IQ8 HC do not support Power control systems. Enphase is evaluating the features of these models, which will be made available soon.

4. **Aggregate Power Export Limit mode:** This PCS feature ensures that the aggregate PV power exported to the grid is limited to the Aggregate Power Export Limit (PEL) value set by the installer. This ensures the aggregate power export is below the level defined, as measured at the Consumption CTs. The battery never exports to the grid. Thus, it's a PV feature. Only IQ8 Series Microinverters used with IQ Combiner 5/5C support this feature.



NOTE: Currently, IQ8 MC, IQ8 AC, and IQ8 HC do not support power control systems. Enphase is evaluating the features of these models, which will be made available soon.

For further information, refer to the Power Control Systems (PCS) tech brief.

Position of Consumption CT in systems using Power Control Systems (PCS)

1. All grid-forming systems must have Consumption CTs installed.
2. The Consumption CT shall be placed between the main panel and utility meter for all systems by default.
3. For grid-forming systems that need to enable MPU avoidance, the Consumption CT must be placed between the IQ System Controller and the main panel.
4. Grid-tied systems that need to enable MPU avoidance need not have a Consumption CT installed.
5. Grid-tied systems that need to enable aggregate PV export limiting must have a Consumption CT installed between the main panel and the utility meter.

Economic use cases

There are many economic goals that the Enphase Energy System supports. These include **reducing the utility bill** by charging during low tariff periods and saving energy to ensure that loads can be served

through the battery(ies) during the peak tariff period. Power from PV can be exported to the grid, especially during peak tariff periods.

The system also supports the special case of **power export limiting**, where the utility does not allow a homeowner to export power from the PV system to the grid. Examples are the Hawaii self-supply and NEM+ programs, where no export is allowed, which is called **zero export**.

Optimizing energy storage capacity sizing for economic use cases is beyond the scope of this document. You can use simulation tools like NREL SAM (System Advisor Model) or Energy Tool base to assist with sizing in these use cases.

System profiles

The Enphase Energy System supports three smart profiles for the batteries to implement the Backup, Self-Consumption, and economic use cases.

These are:

1. **Full Backup:** 100% of the battery capacity is reserved for backup, and the battery does not discharge while on-grid. This profile is not available in grid-tied configurations.
2. **Self-Consumption:** The battery discharges till reserved capacity to ensure the home loads are served with PV and storage as far as possible. Effectively the system tries to reduce imports from the grid whenever possible. Note the Battery Only discharges till the reserve charge limit while on-grid. The battery discharges below the reserve charge limit only when the grid is down. This profile is not available in battery-only systems.
3. **Savings:** This profile is for the economic use case wherein the battery discharges when the rates are at the peak and charges using PV before peak tariff periods.



NOTE: IQ Battery does not export to the grid. During the peak tariff period, PV is exported to the grid, and the battery is discharged to serve loads.



NOTE: The Battery Only discharges till the reserve charge limit while on-grid. The battery discharges below the reserve charge limit only when the grid is down.

A description of these modes with screenshots of how homeowners can select the same is available in the [Enphase storage system owner's guide](#).



NOTE: In all modes, the battery will charge from the grid till the reserve charge limit to ensure that the desired amount of battery charge for backup is guaranteed to be available.

System sizing

This section is relevant for grid-forming systems only.

Load analysis

A proper load study is the first step in effectively sizing a system. If an IQ Gateway with properly configured Consumption CTs is already installed at a site, Enphase cloud data can be used to size the system properly. Load data for system size can also be obtained through a site survey, utility bills, and third-party consumption meters.

Microinverter array and IQ Battery sizing

A backup system can power loads when the grid is down.

It is important to differentiate the terms power and energy. Power is a measure of the instantaneous electricity used and is expressed in units of watts (W) or kilowatts (kW). Battery power rating indicates how much power can flow out of the battery at any instant. Energy is the integrated power used over time and is expressed in units of watt-hours (Wh) or kilowatt-hours (kWh). When running in the backup operation, any power capacity or energy capacity shortages will result in a loss of power to the loads and should be avoided. Therefore, it is essential to size the system for both power and energy capacities in each installation.

Sufficiently size the IQ Battery power rating to power loads and charge from PV power generation. You can increase the power rating by adding additional IQ Battery units, which also provide additional backup, improving the customer user experience.

The stand-alone or microgrid power sources must be sufficient to meet the **2020 NEC 710.15(A)** requirements.

- **2020 NEC 710.15 (A) supply output.** Power supply to premises wiring systems shall be permitted to have less capacity than the calculated load. The ability of the stand-alone supply shall be equal to or greater than the load posed by the largest single-utilization equipment connected to the system. Calculated general lighting loads shall not be considered as a single load.
- **Power (kW)** capacity from the IQ Battery² system must exceed the largest single load.
- **Energy storage (kWh)** capacity should be sized to supply the estimated backup loads for a user-defined period.

An additional factor to consider is the inrush current for the device if a large appliance, like an air conditioner or a pool pump, needs to be powered back up. See the product nameplate or the manufacturer's literature to determine the inrush current requirement. To meet this need, the battery array must be of an appropriate size.

Relationship between microinverter and IQ Battery sizing in grid-forming systems

For systems using IQ8 Series Microinverters

For IQ Battery 5P systems

The number of IQ8 Series Microinverters is limited only by the continuous current rating of the PV port in IQ System Controller 3/3G (64A).



NOTE: Additional IQ8 Microinverters must be segregated into a separate grid-tied system with a different IQ Gateway/IQ Combiner 5/5C/4/4C.

For IQ Battery 3T/10T systems

The number of IQ8 Series Microinverters in a microgrid with a single IQ Battery 3T is limited to 48. For systems with more than one IQ Battery 3T, the number of IQ8 Series Microinverters is limited only by the continuous current rating of the PV port in IQ System Controller 2 (64A).



NOTE: Additional IQ8 Microinverters must be segregated into a separate grid-tied system with a different IQ Gateway/IQ Combiner 5/5C/4/4C.

Table 5: Number of IQ8 Series Microinverters supported by grid-forming IQ Battery 3T/10T systems

No. of IQ Battery 3T units	Equivalent 10T units	IQ Battery energy capacity (kWh)	IQ Battery rated continuous output power (kWA)	PV array-rated continuous output power (kWA)	IQ8	IQ8+	IQ8M	IQ8A	IQ8H	IQ8MC	IQ8AC	IQ8HC
1	-	3.36	1.28	1.92	48	48	44	44	40	48	44	40
2	-	6.72	2.56	3.84	64	52	44	44	40	48	44	40
3	1	10.08	3.84	5.76	64	52	44	44	40	48	44	40
4	-	13.44	5.12	7.68	64	52	44	44	40	48	44	40
5	-	16.8	6.40	9.60	64	52	44	44	40	48	44	40
6	2	20.16	7.68	11.52	64	52	44	44	40	48	44	40
7	-	23.52	8.96	13.44	64	52	44	44	40	48	44	40
8	-	26.88	10.24	15.36	64	52	44	44	40	48	44	40
9	3	30.24	11.52	17.28	64	52	44	44	40	48	44	40
10	-	33.6	12.80	19.20	64	52	44	44	40	48	44	40
11	-	36.96	14.08	21.12	64	52	44	44	40	48	44	40
12	4	40.32	15.36	23.04	64	52	44	44	40	48	44	40

For systems using IQ6, IQ7, or M Series Microinverters

To maintain system stability while operating in off-grid mode, the microinverter array-rated continuous output power shall not exceed 150% of the IQ Battery array-rated continuous output power.

The microinverters that can be connected to the PV port of IQ System Controller 2/3/3G are limited by the continuous current rating of the PV port (64 A). Additional PV can be connected to the backup sub-panel and mapped to the same IQ Gateway/IQ Combiner in the microgrid.



NOTE: If the installed PV power exceeds the allowed limit, use PV shedding feature to drop excess PV when the system transitions to off-grid mode.

For IQ Battery 5P systems

Table 6: Microinverter to IQ Battery 5P ratio for sites with IQ6, IQ7, or M Series

No. of IQ Battery 5P units	IQ Battery energy capacity (kWh)	IQ Battery rated continuous output power (kWA)	Microinverter array rated continuous output power (kWA)	IQ6	IQ6+	IQ7	IQ7+	IQ7X	IQ7A	M215	M250
1	4.96	3.84	5.76	25	20	24	19	18	16	26	24
2	9.92	7.68	11.52	50	41	48	39	36	33	53	48
3	14.88	11.52	17.28	75	61	72	59	54	49	80	72
4	19.84	15.36	23.04	100	82	96	79	73	66	106	96
5	24.8	19.20	28.80	125	102	120	99	91	82	133	120
6	29.76	23.04	34.56	150	123	144	119	109	99	160	144
7	34.72	26.88	40.32	175	143	168	138	128	115	186	168
8	39.68	30.72	46.08	200	164	192	158	146	132	213	192



NOTE: If the system has IQ Battery Oversubscription enabled, use the IQ Battery array's revised nameplate power rating to calculate the microinverter array size.

For IQ Battery 3T/10T systems

Table 7: Number of IQ6, IQ7, or M series Microinverters supported by grid-forming IQ Battery 3T/10T systems

No. of IQ Battery 3T units	Equivalent 10T units	IQ Battery energy capacity (kWh)	IQ Battery rated continuous output power (kWA)	PV array-rated continuous output power (kWA)	IQ6	IQ6+	IQ7	IQ7+	IQ7X	IQ7A	M215	M250
1	-	3.36	1.28	1.92	8	6	8	6	6	5	8	8
2	-	6.72	2.56	3.84	16	13	16	13	12	11	17	16
3	1	10.08	3.84	5.76	25	20	24	19	18	16	26	24
4	-	13.44	5.12	7.68	33	27	32	26	24	22	35	32
5	-	16.8	6.40	9.60	41	34	40	33	30	27	44	40
6	2	20.16	7.68	11.52	50	41	48	39	36	33	53	48
7	-	23.52	8.96	13.44	58	47	56	46	42	38	62	56
8	-	26.88	10.24	15.36	66	54	64	52	48	44	71	64
9	3	30.24	11.52	17.28	75	61	72	59	54	49	80	72
10	-	33.6	12.80	19.20	83	68	80	66	61	55	88	80
11	-	36.96	14.08	21.12	91	75	88	72	67	60	97	88
12	4	40.32	15.36	23.04	100	82	96	79	73	66	106	96

Generator sizing

The system architecture restricts the minimum generator nameplate for pairing with a certain number of IQ Battery units to ensure that the generator can be operated safely and not harmed by unintended back-feed from the PV and/or storage. This limit varies according to the microinverter family installed on the roof.



NOTE: Size the generator power rating appropriately to power loads while charging the IQ Batteries. The minimum generator size should be used as a starting point in the design.



NOTE: The battery array in the system must be sized appropriately to support the backed-up loads before the generator connects to the microgrid. Load control must be used to shed any loads the battery cannot support until the generator is connected.



NOTE: The Enphase Installer App allows you to connect a lower or higher nameplate-rated generator to the system than the recommended generator capacity. However, using smaller generators than stated herein may compromise microgrid stability and can damage the generator due to inadvertent back-feed.



NOTE: If the system has 15 kWh energy storage or more, the generator nameplate rating required exceeds the usable power from the generator port (i.e., 15.36 kW or 64 A at 240 V) from the generator. Generator sizes beyond the values mentioned above will not result in any improvement in terms of current or battery charging speed.



NOTE: The nameplate value and maximum continuous generator current can be set in the Enphase Installer App while commissioning the generator. The IQ Gateway will ensure that the system does not draw more than the generator nameplate rating and keeps generator usage below the maximum continuous generator current.



NOTE: If the system has IQ Battery Oversubscription enabled, use the IQ Battery array's revised nameplate power rating to calculate the generator size.

For Solar Only grid-forming system (Sunlight Backup)

The minimum generator nameplate rating must be at least 100% of the microinverter array's rated AC power output. The following table shows some examples of this pairing.

Table 8: Examples of minimum generator nameplate rating calculation for a Sunlight Backup system

Microinverter type	Rated output (W) of one microinverter	No. of microinverters	Minimum generator nameplate (kW)
IQ8	240	16 (one branch circuit)	3.84
IQ8	240	32 (two branch circuits)	7.68
IQ8PLUS	290	13 (one branch circuit)	3.77
IQ8PLUS	290	20 (two branch circuits)	5.8
IQ8H-240	380	15 (two branch circuits)	5.7

For Battery Only systems

The minimum generator nameplate rating must be 143% of the IQ Battery array.

For IQ Battery 5P

Table 9: Minimum generator nameplate rating for a system with IQ Battery 5P

IQ Battery 5P units	IQ Battery power (kW)	Minimum generator nameplate (kW)
1	3.84	5.49
2	7.68	10.98
3	11.52	16.47
4	15.36	21.96
5	15.36	21.96
6	15.36	21.96
7	15.36	21.96
8	15.36	21.96

For IQ Battery 3T/10T systems

Table 10: Minimum generator nameplate rating for a system with IQ Battery 5P

No. of IQ Battery 3T units	No. of IQ Battery 3T units	IQ Battery rated continuous output power (kWA)	IQ Battery rated continuous output power (kWA)
1	-	1.28	1.83
2	-	2.56	3.66
3	1	3.84	5.49
4	-	5.12	7.32
5	-	6.40	9.15
6	2	7.68	10.98
7	-	8.96	12.81
8	-	10.24	14.64
9	3	11.52	16.47
10	-	12.80	18.30
11	-	14.08	20.13
12	4	15.36	21.96

For Solar + Battery grid-forming systems

For systems with IQ8 Series Microinverters with IQ Battery 5P or IQ Battery 3T/10T

The minimum generator nameplate rating must be a) 100% of the microinverter array-rated AC power output or b) 143% of the IQ Battery array, **whichever is higher**. The following table shows some examples of generator pairing with an Enphase Energy System with IQ8 Series Microinverters and IQ Battery.

Table 11: Examples of minimum generator nameplate rating for a system with IQ8 Series Microinverters and IQ Battery 5P

Microinverter type	Rated output (W) of one microinverter	No. of microinverters	The rated power output of the microinverter array (kW)	IQ Battery 5P units	IQ Battery power (kW)	Minimum generator nameplate (kW)
IQ8	240	16 (one branch circuit)	3.84	1	3.84	5.49
IQ8	240	32 (two branch circuits)	7.68	1	3.84	7.68
IQ8PLUS	290	13 (one branch circuit)	3.77	2	7.68	10.98
IQ8PLUS	290	20 (two branch circuits)	5.8	3	11.52	16.47
IQ8H-240	380	15 (two branch circuits)	5.7	4	15.36	21.96
IQ8H-240	380	40 (four branch circuits)	15.2	4	15.36	21.96
IQ8H-240	380	40 (four branch circuits)	15.2	4	15.36	21.96

Table 12: Examples of minimum generator nameplate rating for a system with IQ8 Series Microinverters and IQ Battery 3T/10T

Microinverter type	Rated output (W) of one microinverter	No. of microinverters	Rated output power output of the Microinverter array (kW)	IQ Battery 3/3T units	IQ Battery 10/10T units	IQ Battery power (kW)	Minimum generator nameplate (kW)
IQ8	240	16 (one branch circuit)	3.84	1	-	1.28	3.84
IQ8	240	32 (two branch circuits)	7.68	2	-	2.56	7.68
IQ8PLUS	290	13 (one branch circuit)	3.77	3	(One IQ Battery 10/10T)	3.84	5.49
IQ8PLUS	290	20 (two branch circuits)	5.8	4	-	5.12	7.31
IQ8H-240	380	15 (two branch circuits)	5.7	5	-	6.4	9.14
IQ8H-240	380	40 (four branch circuits)	15.2	6	(Two IQ Battery 10/10T)	7.68	15.2
IQ8H-240	380	40 (four branch circuits)	15.2	12	(Two IQ Battery 10/10T)	15.36	21.94

For systems with IQ6, IQ7 Series Microinverters with IQ Battery 5P or IQ Battery 3T/10T

The minimum generator nameplate rating must be 143% of the IQ Battery array.

Table 13: Minimum generator nameplate rating for a system with IQ Battery 5P

IQ Battery 5P units	IQ Battery power (kW)	Minimum generator nameplate (kW)
1	3.84	5.49
2	7.68	10.98
3	11.52	16.47
4	15.36	21.96
5	15.36	21.96
6	15.36	21.96
7	15.36	21.96
8	15.36	21.96

Table 14: Minimum generator nameplate rating for a system with IQ Battery 5P

No. of IQ Battery 3T units	Equivalent 10T units	IQ Battery rated continuous output power (kWA)	Minimum generator nameplate (kW)
1	-	1.28	1.83
2	-	2.56	3.66
3	1	3.84	5.49
4	-	5.12	7.32
5	-	6.40	9.15
6	2	7.68	10.98
7	-	8.96	12.81
8	-	10.24	14.64
9	3	11.52	16.47
10	-	12.80	18.30
11	-	14.08	20.13
12	4	15.36	21.96

For systems with M Series Microinverters with IQ Battery 5P or IQ Battery 3T/10

For M Series systems, there is no PV-to-generator power ratio because the microinverter array needs to be disconnected from the microgrid when the generator is connected and generating power.

Storage system sizing

Solar Only grid-forming (Sunlight Backup) configuration

1. Select the absolute minimum number of IQ8 Series Microinverters required to meet the 2020 NEC 710.15 (A) requirements based on the largest maximum single load power rating (kW) that must be backed up. In an IQ8 PV backup system, the IQ8 PV capacity can be added to the system's stand-alone supply to meet the 2020 NEC 710.15 standard (A). However, because solar resources are highly variable, Enphase suggests a safety margin to improve customer experience. As a starting

point for the design, 30% of the PV AC apparent power is suggested. For example, Enphase recommends that the greatest single load on a 6 kVA AC PV system not exceed 1.8 kVA.

2. If the system has a generator, PV shedding may need to be implemented to maintain system stability as described in the section [Generator sizing](#).
3. Only up to four 240 V or up to eight 120 V pre-selected essential load circuits can be backed up in this configuration. All these loads must be controlled using the IQ Load Controller. Each 240 V load can be regulated independently; however, 120 V loads can only be handled in groups of up to two. Refer to [Load and solar circuit control using IQ System Controller auxiliary contacts](#) for more details.

For Battery Only backup configurations

For IQ Battery 3T/10T systems

1. Identify the largest single load power rating (kW) you want to back up and select the minimum IQ Battery 3T/10T units required to meet the 2020 NEC 710.15(A) requirements.
2. If the system has a generator, additional units may be needed to maintain system stability as described in the section *Generator sizing*.
3. Based on the estimated backup loads for the user-defined period, calculate the required energy storage (kWh) capacity and the minimum IQ Battery 3T/10T units needed.
4. Based on a site's load analysis of both power (kW) and energy capacity (kWh) needed, determine the total number of IQ Battery 3T/10T units required for the storage system.
 - a. The minimum IQ Battery 3T/10T units required is calculated as the largest of step 1 and step 2.
 - b. The desired number of IQ Battery 3T/10T units is the value calculated in step 2.



NOTE: Up to 40 kWh of IQ Battery 3T/10T can be connected to a single IQ System Controller 2.



NOTE: Load Controller is recommended for all backup load circuits that exceed the storage power capacity. Refer to [Load and Solar Circuit Control using IQ System Controller Auxiliary Contacts](#) for more details.

For IQ Battery 5P systems

1. Identify the largest single load power rating (kW) you want to back up and select the minimum IQ Battery 5P units required to meet the 2020 NEC 710.15(A) requirements.
2. If the system has a generator, additional units may be needed to maintain system stability as described in the section *Generator sizing*.
3. Based on the estimated backup loads for the user-defined period, calculate the required energy storage (kWh) capacity and the minimum IQ Battery 5P units required.
4. Based on a site's load analysis of both power (kW) and energy capacity (kWh), determine the total number of IQ Battery 5P units required for the storage system.
 - a. The minimum IQ Battery 3T/10T units required is calculated as the largest of steps 1 and 2.
 - b. The desired number of IQ Battery 5P units is the value calculated in step 3.



NOTE: Using the IQ Battery Oversubscription feature, up to 40 kWh of IQ Battery 5P can be connected to each IQ System Controller 3/3G battery port with a rated power output of 15.36 kW. As a result, the IQ System Controller 3G can support up to 40 kWh of IQ Battery 5P, while the IQ System Controller 3 can support up to 80 kWh of IQ Battery 5P.



NOTE: IQ Battery oversubscription maintains the overload capability of IQ Battery 5P at 200% of the original nameplate rating for 1.5 seconds.



NOTE: Load Controller is recommended for all backup load circuits that exceed the storage power capacity. Refer to [Load and solar circuit control using IQ System Controller auxiliary contacts](#) for more details.

For Solar + Battery backup configurations

For IQ Battery 3T/10T systems

1. Identify the largest single load power rating (kW) you want to back up and select the minimum IQ Battery 3T/10T units required to meet the 2020 NEC 710.15(A) requirements.
2. Additional battery units may be required to maintain system stability depending on the microinverter used in the system, as described in the section *Relationship between microinverter and IQ Battery sizing in grid-forming systems*.
3. If the system has a generator, additional units may be needed to maintain system stability as described in the section *Generator sizing*.
4. Based on the estimated backup loads for the user-defined period, calculate the required energy storage (kWh) capacity and the minimum number of IQ Battery 3T/10T units needed.
5. Based on a site's load analysis of both power (kW) and energy capacity (kWh) needed, determine the total number of IQ Battery 3T/10T units required for the storage system.
 - a. The minimum number of IQ Battery 3T/10T units required is calculated as the largest of step 1, step 2, and step 3.
 - b. The desired number of IQ Battery 3T/10T units is the value calculated in step 2.



NOTE: Up to 40 kWh of IQ Battery 3T/10T can be connected to a single IQ System Controller 2.



NOTE: Load Controller is recommended for all backup load circuits that exceed the storage power capacity. Refer to [Load and solar circuit control using IQ System Controller auxiliary contacts](#) for more details.

For IQ Battery 5P systems

1. Identify the largest single load power rating (kW) you want to back up and select the minimum IQ Battery 5P units required to meet the 2020 NEC 710.15(A) requirements.
2. Additional battery units may be required to maintain system stability depending on the microinverter used in the system, as described in the section *Relationship between microinverter and IQ Battery sizing in grid-forming systems*.
3. If the system has a generator, additional units may be needed to maintain system stability as described in the section *Generator sizing*.
4. Based on the estimated backup loads for the user-defined period, calculate the required energy storage (kWh) capacity and the minimum IQ Battery 5P units required.
5. Based on a site's load analysis of both power (kW) and energy capacity (kWh), determine the total number of IQ Battery 5P units required for the storage system.
 - a. The minimum number of IQ Battery 3T/10T units required is calculated as the largest of steps 1, step 2, and step 3.
 - b. The desired number of IQ Battery 5P units is the value calculated in step 3.



NOTE: Using the IQ Battery Oversubscription feature, up to 40 kWh of IQ Battery 5P can be connected to each IQ System Controller 3/3G battery port with a rated power output of 15.36 kW. As a result, the IQ System Controller 3G can support up to 40 kWh of IQ Battery 5P, while the IQ System Controller 3 can support up to 80 kWh of IQ Battery 5P.



NOTE: IQ Battery oversubscription maintains the overload capability of IQ Battery 5P at 200% of the original nameplate rating for 1.5 seconds.



NOTE: Load Controller is recommended for all backup load circuits that exceed the storage power capacity. Refer to [Load and solar circuit control using IQ System Controller auxiliary contacts](#) for more details.

Component list for different system configurations

Component list for Solar Only or Battery Only system configurations

With IQ Battery 5P and/or IQ System Controller 3/3G

Table 15: Component list for Solar Only or Battery Only system configurations

Component type	Product name and model number	Solar Only	Sunlight Backup	Battery Only grid-tied	Battery Only grid-forming
Microinverters	IQ8 Series IQ8-60-2-US IQ8PLUS-72-2-US IQ8M-72-2-US IQ8A-72-2-US IQ8H-240-72-2-US IQ8MC-72-M-US IQ8AC-72-M-US IQ8HC-72-M-US	As needed per system design	As needed per system design (up to 64 A continuous)	0	0
	IQ8 Series IQ8H-208-72-2-US	As needed per system design (IQ Battery integration not supported)	Not supported	0	0
	IQ7 Series IQ7-60-2-US IQ7PLUS-72-2-US IQ7X-96-2-US IQ7A-72-2-US	As needed per system design	Not supported	0	0
	IQ6 Series IQ6-60-2-US IQ6PLUS-72-2-US	As needed per system design	Not supported	0	0
	M Series M215-60-2LL-S22-IG M215-60-2LL-S25-IG	As needed per system design	Not supported	0	0

Component type	Product name and model number	Solar Only	Sunlight Backup	Battery Only grid-tied	Battery Only grid-forming
	M250-60-2LL-S22 M250-60-2LL-S25 M250-72-2LL-S22 M250-72-2LL-S25				
Battery	IQ Battery 5P IQBATTERY-5P-1P-NA	-	-	As needed per system design, up to 16 units maximum (does not support 208 V operation)	As needed per system design, up to 16 units maximum (does not support 208 V operation)
	IQ Battery 5P Pedestal for NA B05-PI-0550-O	0	0	Optional (1 per IQ Battery 5P)	Optional (1 per IQ Battery 5P)
	IQ Battery 5P Lifting Handle IQBATTERY-HNDL-5	0	0	1	1
AC Combiner	IQ Combiner 5/5C X-IQ-AM1-240-5 OR X-IQ-AM1-240-5C (includes IQ Gateway, 2 Consumption CTs, and 1 Battery CT)	1 (not for M Series)	1	1	1
Gateway	IQ Gateway for IQ Series ENV-IQ-AM1-240 ENV2-IQ-AM1-240 ²	1 (if not using IQ Combiner; not for M Series)	0	1 (if not using IQ Combiner)	1 (if not using IQ Combiner)
	ENV-S-AM1-120	1 (only for M Series)	Not supported	Not supported	Not supported
Load Control	IQ Load Controller EP-NA-LK02-040	0	1 or 2	0	1 or 2
Enphase Energy System communications	Enphase Communications Kit COMMS-KIT-02 (Includes 1 Battery CT, Power Jumper for IQ Gateway, and NEMA 4X enclosure)	0	0	1 (If not using IQ Combiner)	1 (If not using IQ Combiner)
Cellular Modem	Enphase Mobile Connect CELLMODEM-M1-06-SP-05 (T-Mobile/Sprint 5-year data plan)	0 or 1 (if not using IQ Combiner 5C)	0 or 1 (if not using IQ Combiner 5C)	0 or 1 (if not using IQ Combiner 5C)	0 or 1 (if not using IQ Combiner 5C)

² Use this SKU in jurisdictions that mandate IEEE 1547:2018 compliance.

Component type	Product name and model number	Solar Only	Sunlight Backup	Battery Only grid-tied	Battery Only grid-forming
	CELLMODEM-M1-06-AT-05 (AT&T 5-year data plan)				
Current Transformers	Consumption CTs CT-200-SPLIT or CT-200-CLAMP	2 (if not using IQ Combiner 5/5C)	2 (if not using IQ Combiner 5/5C)	0	0
	Battery CT CT-200-CLAMP (Included with IQ Combiner 5/5C as well as with COMMS-KIT-02)	0	0	0	0
	Generator CT CT-200-CLAMP	0	2 (if using a generator, it must be purchased separately)	0	2 (if using a generator, it must be purchased separately)
IQ Combiner 5/5C Hold-Down Kit	Hold-Down Kit for IQ Combiner 5/5C X-IQ-NA-HD-125A	0	1 or 2 (only for IQ8 Series systems)	0	0
IQ Combiner 5/5C breakers	PV branch circuit breakers BRK-20A-2P-240V BRK-20A-2P-240V-B (for grid-forming IQ8)	1,2,3 or 4 (if using IQ Combiner 5/5C)	1,2,3 or 4 (if using IQ Combiner 5/5C)	0	0
	Storage branch circuit breakers ³ BRK-20A-2P-240V BRK-40A-2P-240V BRK-60A-2P-240V	0	0	1,2,3 or 4 (if using IQ Combiner 5/5C)	1,2,3 or 4 (if using IQ Combiner 5/5C)
IQ System Controller	For systems without generators IQ System Controller 3 SC200D111C240US01. ⁴	0	1	0	1
	For systems with generator IQ System Controller 3G	0	1	0	1

³ Sum of ratings of the storage branch circuit breakers shall not exceed 80A if using IQ Combiner 5/5C

⁴ Both IQ System Controller 3 and IQ System Controller 3G ship with Enphase System Shutdown Switch (rapid shutdown switch) and pre-installed hold-down kit on all 3 DER circuits. Separate hold-down kits are not needed.

Component type	Product name and model number	Solar Only	Sunlight Backup	Battery Only grid-tied	Battery Only grid-forming
	SC200G111C240US01 ⁵				
	Main breaker and/or load breaker for IQ System Controller 3/3G BRK-200A-2P-240V (Eaton SKU: CSR2200N) BRK-175A-2P-240V (Eaton SKU: CSR2175N) BRK-150A-2P-240V (Eaton SKU: CSR2150N) BRK-125A-2P-240V (Eaton SKU: CSR2125N) BRK-100A-2P-240V (Eaton SKU: CSR2100)	0	0, 1, or 2	0	0, 1, or 2
	IQ System Controller 3/3G circuit breakers⁶ BRK-40A-2P-240V (Eaton SKU: BR240) BRK-40A-2P-240V-B (Eaton SKU: BR240B) BRK-60A-2P-240V (Eaton SKU: BR260) BRK-80A-2P-240V (Eaton SKU: BR280) BRK-20A-2P-240V-B (Eaton SKU: BR220B) BRK-30A-2P-240V (Eaton SKU: BR230B)	0	0, 1, or 2	0	0, 1, or 2
Control cable	CTRL-SC3-NA-01	-	As needed	As needed	As needed

With IQ Battery 3T/10T and/or IQ System Controller 2

Table 16: Component list for with IQ Battery 3T/10T and/or IQ System Controller 2

Component type	Product name and model number	Solar Only grid-tied	Sunlight Backup	The battery grid-tied	Battery-only grid-forming
Microinverters	IQ8 Series IQ8-60-2-US IQ8PLUS-72-2-US IQ8M-72-2-US IQ8A-72-2-US	As needed per system design	As needed per system design (up to 64 A continuous)	0	0

⁵ Both IQ System Controller 3 and IQ System Controller 3G ship with Enphase System Shutdown Switch (rapid shutdown switch) and pre-installed hold-down kit on all 3 DER circuits. Separate hold-down kits are not needed.

⁶ IQ System Controller 3/3G is compatible with ABB/GE and Siemens breakers for DERs.

Component type	Product name and model number	Solar Only grid-tied	Sunlight Backup	The battery grid-tied	Battery-only grid-forming
	IQ8H-240-72-2-US IQ8MC-72-M-US IQ8AC-72-M-US IQ8HC-72-M-US				
	IQ8 Series IQ8H-208-72-2-US	As needed per system design	Not supported	0	0
	IQ7 Series IQ7-60-2-US IQ7PLUS-72-2-US IQ7X-96-2-US IQ7A-72-2-US	As needed per system design	Not supported	0	0
	IQ6 Series IQ6-60-2-US IQ6PLUS-72-2-US	As needed per system design	Not supported	0	0
	M Series M215-60-2LL-S22-IG M215-60-2LL-S25-IG M250-60-2LL-S22 M250-60-2LL-S25 M250-72-2LL-S22 M250-72-2LL-S25	As needed per system design	Not supported	0	0
IQ Battery	IQ Battery 3T/10T	0	0	As needed per system design (does not support 208 V operation)	As needed per system design (does not support 208 V operation)
	Battery lifting handle ENCHARGE-HNDL-R1	0	0	1	1
AC Combiner	IQ Combiner 4/4C X-IQ-AM1-240-4 OR X-IQ-AM1-240-4C OR X2-IQ-AM1-240-4 ⁷ OR X2-IQ-AM1-240-4C ⁷ OR (includes IQ Gateway and 2 Consumption CTs)	1 (not for M-series)	1	1	1
Gateway	IQ Gateway for IQ Series ENV-IQ-AM1-240 ENV2-IQ-AM1-240 ⁷	1 (if not using IQ Combiner; not for M Series)	0	1 (if not using IQ Combiner)	1 (if not using IQ Combiner)
	ENV-S-AM1-120	1 (only for M Series)	Not supported	0	0

⁷ Use this SKU in jurisdictions that mandate IEEE 1547:2018 compliance.

Component type	Product name and model number	Solar Only grid-tied	Sunlight Backup	The battery grid-tied	Battery-only grid-forming
Load Control	IQ Load Controller EP-NA-LK02-040	0	1 or 2	0	1 or 2
Enphase Energy System communications	Enphase Communications Kit COMMS-KIT-01	0	1	1	1
Cellular Modem	Enphase Mobile Connect CELLMODEM-M1-06-SP-05 (T-Mobile/Sprint 5-year data plan) CELLMODEM-M1-06-AT-05 (AT&T 5-year data plan)	0 or 1 (if not using IQ Combiner 4C)	0 or 1 (if not using IQ Combiner 4C)	0 or 1 (if not using IQ Combiner 4C)	0 or 1 (if not using IQ Combiner 4C)
Current Transformers	Consumption CTs CT-200-SPLIT or CT-200-CLAMP	2 (if not using IQ Combiner 4/4C)	2 (if not using IQ Combiner 4/4C)	2 (if not using IQ Combiner 4/4C)	2 (if not using IQ Combiner 4/4C)
	Generator CT CT-200-CLAMP	0	2 (if using generator, it must be purchased separately)	0	2 (if using generator, it must be purchased separately)
IQ Combiner 4/4C Hold-Down Kit	Hold-Down Kit for IQ Combiner 4/4C X-IQ-NA-HD-125A	0	1 or 2 (only for IQ8 Series systems)	0	0
IQ Combiner 4/4C breakers	PV branch circuit breakers BRK-20A-2P-240V BRK-20A-2P-240V-B (for grid-forming IQ8)	1,2,3 or 4 (if using IQ Combiner 4/4C)	1,2,3 or 4 (if using IQ Combiner 4/4C)	0	0
	Storage branch circuit breaker ⁸ BRK-20A-2P-240V BRK-40A-2P-240V BRK-60A-2P-240V	0	0	1,2,3 or 4 (if using IQ Combiner 4/4C)	1,2,3 or 4 (if using IQ Combiner 4/4C)
System Controller	IQ System Controller 2 EP200G-SC2-RSD-KIT	0	1	0	1
	Hold-down kit for IQ System Controller 2 EP200G-NA-HD-200A	0	1	0	1
	Main breaker and/or load breaker for IQ	0	0, 1, or 2	0	0, 1, or 2

⁸ Sum of ratings of the Storage branch circuit breakers shall not exceed 80A if using IQ Combiner 4/4C.

Component type	Product name and model number	Solar Only grid-tied	Sunlight Backup	The battery grid-tied	Battery-only grid-forming
	System Controller 2 BRK-200A-2P-240V (Eaton SKU: CSR2200N) BRK-175A-2P-240V (Eaton SKU: CSR2175N) BRK-150A-2P-240V (Eaton SKU: CSR2150N) BRK-125A-2P-240V (Eaton SKU: CSR2125N) BRK-100A-2P-240V (Eaton SKU: CSR2100)				
	IQ System Controller 2 circuit breakers BRK-40A-2P-240V-B (Eaton SKU: BR240B) BRK-60A-2P-240V (Eaton SKU: BR260) BRK-80A-2P-240V (Eaton SKU: BR280) BRK-20A-2P-240V-B (Eaton SKU: BR220B) BRK-30A-2P-240V (Eaton SKU: BR230B)	0	0, 1, or 2	0	0, 1, or 2

Component list for Solar + Battery system configurations

With IQ Battery 5P and/or IQ System Controller 3/3G

Table 17: Component list for with IQ Battery 5P and/or IQ System Controller 3/3G

Component type	Product name and model number	Grid-tied system	Whole home backup	Partial home backup
Microinverters	IQ8 Series IQ8-60-2-US IQ8PLUS-72-2-US IQ8M-72-2-US IQ8A-72-2-US IQ8H-240-72-2-US IQ8MC-72-M-US IQ8AC-72-M-US IQ8HC-72-M-US	As needed per system design	As needed per system design (up to 64 A continuous)	As needed per system design (up to 64 A continuous)
	IQ8 Series IQ8H-208-72-2-US	As needed per system design (IQ Battery integration not supported)	Not Supported	Not supported
	IQ7 Series IQ7-60-2-US	As needed per system design	As needed per system design	As needed per system design

Component type	Product name and model number	Grid-tied system	Whole home backup	Partial home backup
	IQ7PLUS-72-2-US IQ7X-96-2-US IQ7A-72-2-US			
	IQ6 Series IQ6-60-2-US IQ6PLUS-72-2-US	As needed per system design	As needed per system design	As needed per system design
	M Series M215-60-2LL-S22-IG M215-60-2LL-S25-IG M250-60-2LL-S22 M250-60-2LL-S25 M250-72-2LL-S22 M250-72-2LL-S25	As needed per system design	As needed per system design	As needed per system design
Batteries	IQ Batteries IQ Battery-5P-1P-NA	As needed per system design (Does not support 208 V operation)	As needed per system design, up to 16 units maximum (does not support 208 V operation)	As needed per system design, up to 16 units maximum (does not support 208 V operation)
	IQ Battery 5P Pedestal for NA B05-PI-0550-O	Optional (1 per IQ Battery 5P)	Optional (1 per IQ Battery 5P)	Optional (1 per IQ Battery 5P)
	IQ Battery 5P Lifting Handle IQBATTERY-HNDL-5	1	1	1
AC Combiner	IQ Combiner 5/5C X-IQ-AM1-240-5 OR X-IQ-AM1-240-5C (includes IQ Gateway, two Consumption CTs, and one Battery CT)	1 (not for M Series Microinverters)	1 (not for M Series Microinverters)	1 (not for M Series Microinverters)
Gateway	IQ Gateway for IQ Series ENV-IQ-AM1-240 ENV2-IQ-AM1-240 ⁹	1 (if not using IQ Combiner 5/5C; not for M Series Microinverters)	1 (if not using IQ Combiner 5/5C; not for M Series Microinverters)	1 (if not using IQ Combiner 5/5C; not for M Series Microinverters)
	Envoy S Metered ENV-S-AM1-120	1 (for M Series Microinverters)	1 (for M Series Microinverters)	1 (for M Series Microinverters)
Load Control	IQ Load Controller EP-NA-LK02-040	0	0, 1, or 2	0, 1, or 2
Enphase Energy System communications (between IQ Batteries, IQ System Controller)	Enphase Communications Kit COMMS-KIT-02 (Includes 1 Battery CT, Power Jumper for IQ)	1 (if not using IQ Combiner 5/5C)	1 (if not using IQ Combiner 5/5C)	1 (if not using IQ Combiner 5/5C)

⁹ Use this SKU in jurisdictions that mandate IEEE 1547:2018 compliance.

Component type	Product name and model number	Grid-tied system	Whole home backup	Partial home backup
3/3G, and IQ Gateway)	Gateway, and NEMA 4X enclosure)			
Cellular modem	Enphase Mobile Connect CELLMODEM-M1-06-SP-05 (T-Mobile/Sprint 5-year data plan) CELLMODEM-M1-06-AT-05 (AT&T 5-year data plan)	0 or 1 (if not using IQ Combiner 5C)	0 or 1 (if not using IQ Combiner 5C)	0 or 1 (if not using IQ Combiner 5C)
Current Transformers	Consumption CTs CT-200-SPLIT or CT-200-CLAMP	2 (if not using IQ Combiner 5C)	2 (if not using IQ Combiner 5C)	2 (if not using IQ Combiner 5C)
	Battery CT CT-200-SPLIT or CT-200-CLAMP (Included with IQ Combiner 5/5C as well as with COMMS-KIT-02)	0	0	0
	Generator CTs CT-200-CLAMP	0	2 (if using a generator, it must be purchased separately)	2 (if using a generator, it must be purchased separately)
IQ Combiner 5/5C hold-down kit	Hold-Down Kit for IQ Combiner 5/5C X-IQ-NA-HD-125A (for grid-forming IQ8)	0	1 for PV branch circuits ≤ 2 ; 2 for PV branch circuits > 2 and ≤ 4 (if using IQ Combiner 5/5C)	1 for PV branch circuits ≤ 2 ; 2 for PV branch circuits > 2 and ≤ 4 (if using IQ Combiner 5/5C)
IQ Combiner 5/5C breakers	PV branch circuit breakers BRK-20A-2P-240V BRK-20A-2P-240V-B (for grid-forming IQ8)	1,2,3 or 4 (if using IQ Combiner 5/5C)	1,2,3 or 4 (if using IQ Combiner 5/5C)	1,2,3 or 4 (if using IQ Combiner 5/5C)
	Storage branch circuit breakers ¹⁰ BRK-20A-2P-240V BRK-40A-2P-240V BRK-60A-2P-240V	1,2,3 or 4 (if using IQ Combiner 5/5C)	0	0
IQ System Controller	For systems without generators	0	1	1

¹⁰ Sum of ratings of the Storage branch circuit breakers shall not exceed 80A when using IQ Combiner 5/5C

Component type	Product name and model number	Grid-tied system	Whole home backup	Partial home backup
	IQ System Controller 3 SC200D111C240US01 ¹¹			
	For systems with generator IQ System Controller 3G SC200G111C240US01 ¹²	0	1	1
	Main breaker and/or load breaker for IQ System Controller 3/3G BRK-200A-2P-240V (Eaton SKU: CSR2200N) BRK-175A-2P-240V (Eaton SKU: CSR2175N) BRK-150A-2P-240V (Eaton SKU: CSR2150N) BRK-125A-2P-240V (Eaton SKU: CSR2125N) BRK-100A-2P-240V (Eaton SKU: CSR2100)	1	0, 1, or 2	0, 1, or 2
	IQ System Controller 3/3G circuit breakers ¹³ BRK-40A-2P-240V (Eaton SKU: BR240) BRK-40A-2P-240V-B (Eaton SKU: BR240B) BRK-60A-2P-240V (Eaton SKU: BR260) BRK-80A-2P-240V (Eaton SKU: BR280) BRK-20A-2P-240V-B (Eaton SKU: BR220B) BRK-30A-2P-240V (Eaton SKU: BR230B)	0	0, 1, or 2	0, 1, or 2
Control cable	CTRL-SC3-NA-01	-	As needed	As needed

¹¹ IQ System Controller 3 and IQ System Controller 3G ship with Enphase System Shutdown Switch (rapid shutdown switch) and pre-installed hold-down kit on all 3 DER circuits. Separate hold-down kits are not needed.

¹² Both IQ System Controller 3 and IQ System Controller 3G ship with Enphase System Shutdown Switch (rapid shutdown switch) and pre-installed hold-down kit on all 3 DER circuits. Separate hold-down kits are not needed.

¹³ IQ System Controller 3/3G is compatible with ABB/GE and Siemens breakers for DERs.

With IQ Battery 3T/10T and/or IQ System Controller 2

Table 18: Component list for with IQ Battery 3T/10T and/or IQ System Controller 2

Component type	Product name and model number	Grid-tied system	Whole home backup	Partial home backup
Microinverters	IQ8 Series IQ8-60-2-US IQ8PLUS-72-2-US IQ8M-72-2-US IQ8A-72-2-US IQ8H-240-72-2-US IQ8MC-72-M-US IQ8AC-72-M-US IQ8HC-72-M-US	As needed per system design	As needed per system design (up to 64 A continuous)	0
	IQ8 Series IQ8H-208-72-2-US	As needed per system design	Not supported	0
	IQ7 Series IQ7-60-2-US IQ7PLUS-72-2-US IQ7X-96-2-US IQ7A-72-2-US	As needed per system design	Not supported	0
	IQ6 Series IQ6-60-2-US IQ6PLUS-72-2-US	As needed per system design	Not supported	0
	M Series M215-60-2LL-S22-IG M215-60-2LL-S25-IG M250-60-2LL-S22 M250-60-2LL-S25 M250-72-2LL-S22 M250-72-2LL-S25	As needed per system design	Not supported	0
IQ Battery	IQ Battery 3T/10T	As needed per system design (does not support 208 V operation)	0	As needed per system design (does not support 208 V operation)
	Battery lifting handle ENCHARGE-HNDL-R1	0	0	1
AC Combiner	IQ Combiner 4/4C X-IQ-AM1-240-4 OR X-IQ-AM1-240-4C OR X2-IQ-AM1-240-4 ¹⁴ OR X2-IQ-AM1-240-4C ⁷ OR (includes IQ Gateway and 2 Consumption CTs)	1 (not for M Series)	1	1

¹⁴ Use this SKU in jurisdictions that mandate IEEE 1547:2018 compliance.

Component type	Product name and model number	Grid-tied system	Whole home backup	Partial home backup
Gateway	IQ Gateway for IQ Series ENV-IQ-AM1-240 ENV2-IQ-AM1-240 ⁷	1 (if not using IQ Combiner; not for M Series)	0	1 (if not using IQ Combiner)
	ENV-S-AM1-120	1 (only for M Series)	Not supported	0
Load Control	IQ Load Controller EP-NA-LK02-040	0	1 or 2	0
Enphase Energy System communications	Enphase Communications Kit COMMS-KIT-01	1	1	1
Cellular Modem	Enphase Mobile Connect CELLMODEM-M1-06-SP-05 (T-Mobile/Sprint 5-year data plan) CELLMODEM-M1-06-AT-05 (AT&T 5-year data plan)	0 or 1 (if not using IQ Combiner 4C)	0 or 1 (if not using IQ Combiner 4C)	0 or 1 (if not using IQ Combiner 4C)
Current Transformers	Consumption CTs CT-200-SPLIT or CT-200-CLAMP	2 (if not using IQ Combiner 4/4C)	2 (if not using IQ Combiner 4/4C)	2 (if not using IQ Combiner 4/4C)
	Generator CTs CT-200-CLAMP	0	2 (if using a generator, it must be purchased separately)	2 (if using a generator, it must be purchased separately)
IQ Combiner 4/4C Hold-Down Kit	Hold-Down Kit for IQ Combiner 4/4C X-IQ-NA-HD-125A (for grid-forming IQ8)	0	1 for PV branch circuits ≤ 2 . 2 for PV branch circuits > 2 and ≤ 4 (if using IQ Combiner 4/4C)	1 for PV branch circuits ≤ 2 . 2 for PV branch circuits > 2 and ≤ 4 (if using IQ Combiner 4/4C)
IQ Combiner 4/4C breakers	PV branch circuit breakers BRK-20A-2P-240V BRK-20A-2P-240V-B (for grid-forming IQ8)	1,2,3 or 4 (if using IQ Combiner 4/4C)	1,2,3 or 4 (if using IQ Combiner 4/4C)	1,2,3 or 4 (if using IQ Combiner 4/4C)
	Storage branch circuit breaker ¹⁵ BRK-20A-2P-240V BRK-40A-2P-240V BRK-60A-2P-240V	1,2,3 or 4 (if using IQ Combiner 4/4C)	0	0
	IQ System Controller 2	0	1	1

¹⁵ Sum of ratings of the Storage branch circuit breakers shall not exceed 80 A when using IQ Combiner 4/4C

Component type	Product name and model number	Grid-tied system	Whole home backup	Partial home backup
	EP200G-SC2-RSD-KIT			
	Hold-down kit for IQ System Controller 2 EP200G-NA-HD-200A	0	2 for IQ8 Series systems; 1 otherwise	2 for IQ8 Series systems; 1 otherwise
	Main breaker and/or load breaker for IQ System Controller 2 BRK-200A-2P-240V (Eaton SKU: CSR2200N) BRK-175A-2P-240V (Eaton SKU: CSR2175N) BRK-150A-2P-240V (Eaton SKU: CSR2150N) BRK-125A-2P-240V (Eaton SKU: CSR2125N) BRK-100A-2P-240V (Eaton SKU: CSR2100)	0	0, 1, or 2	0
	IQ System Controller 2 circuit breakers BRK-40A-2P-240V-B (Eaton SKU: BR240B) BRK-60A-2P-240V (Eaton SKU: BR260) BRK-80A-2P-240V (Eaton SKU: BR280) BRK-20A-2P-240V-B (Eaton SKU: BR220B) BRK-30A-2P-240V (Eaton SKU: BR230B)	0	0, 1, or 2	0

Grid-tied (without backup) system configurations

Grid-connected systems can generate energy, supply it to home loads, and store it for later use - but only when the grid is available.

Solar Only

During the day, microinverters generate energy and supply loads. If permitted, excess energy is exported to the grid.

With IQ Combiner 5/5C

Figure 2: Solar Only grid-tied configuration with IQ8 or IQ7/IQ6 Series Microinverters and IQ Combiner 5/5C

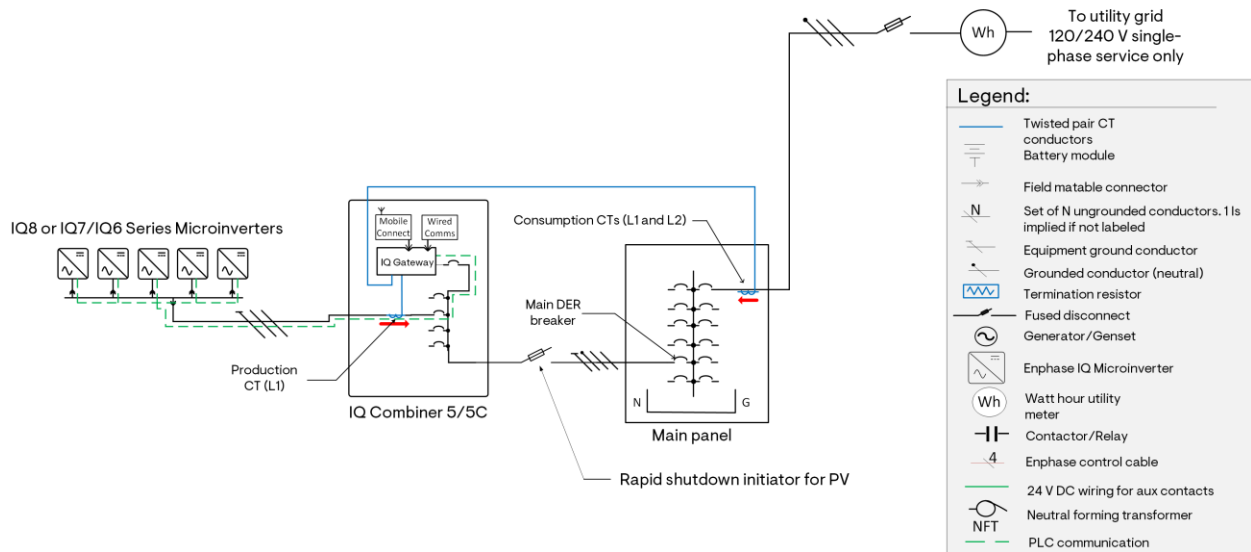

Notes:

- IQ Combiner 5/5C can support DER breakers totaling up to 80 A.
- IQ8 Series Microinverters are incompatible with previous generations of Enphase microinverters, such as IQ6, IQ7, and M Series Microinverters, and cannot be installed together. This holds for all system configurations, both with and without storage.
- Main DER breaker (aggregate DER breaker on the main panel) can act as the rapid shutdown initiator for PV in grid-tied configuration if readily accessible.
- To make it easier to add battery backup functionality in the future, design the system with enough space in the installation area for an IQ System Controller 3/3G and an IQ Battery 5P.



NOTE: If the rated continuous current of an IQ8 or IQ7/IQ6 Microinverter array is greater than 64 A, an IQ Combiner 5/5C cannot be used to aggregate all PV branch circuits. An appropriately sized, off-the-shelf PV sub-panel and a standalone IQ Gateway in a NEMA 3R or higher-rated box can be used for such systems. See [Appendix A](#) for details on the configuration and wiring diagram.

With IQ Combiner 4/4C

Solar Only grid-tied configuration can also utilize IQ Combiner 4/4C to support a continuous PV current of up to 64 A.

Figure 3: Solar Only grid-tied configuration with IQ8 or IQ7/IQ6 Series Microinverters and IQ Combiner 4/4C

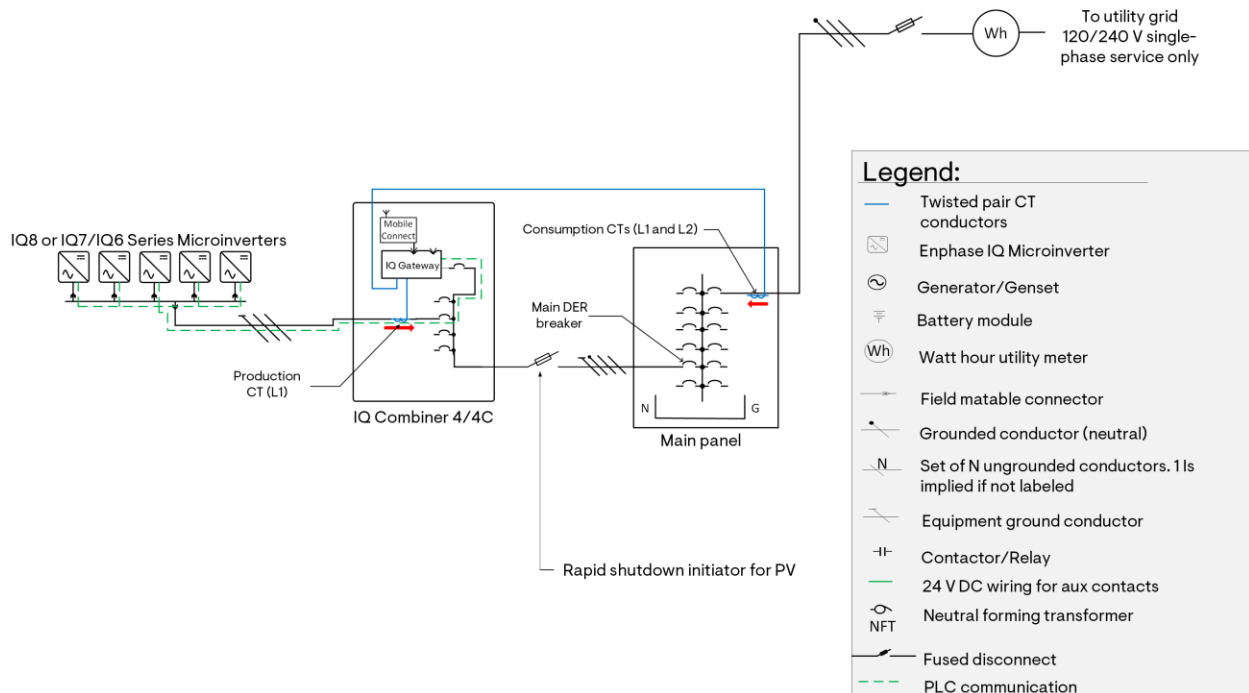

Notes:

- IQ Combiner 4/4C can support DER breakers totaling up to 80 A.
- IQ8 Series Microinverters are incompatible with previous generations of Enphase microinverters, such as IQ6, IQ7, and M Series Microinverters, and cannot be installed together. This holds for all system configurations, both with and without storage.
- Systems with IQ8 Series Microinverters require an IQ Gateway (formerly IQ Envoy) with software version 7. X or higher. The IQ Combiner 4/4C ships preprogrammed with software version 7. X or higher.
- Main DER breaker (aggregate DER breaker on the main panel) can act as the rapid shutdown initiator for PV in grid-tied configuration if it is readily accessible.



NOTE: If the rated continuous current of an IQ8 or IQ7/IQ6 Microinverter array is greater than 64 A, an IQ Combiner 4/4C cannot be used to aggregate all PV branch circuits. An appropriately sized, off-the-shelf PV sub-panel and a standalone IQ Gateway in a NEMA 3R or higher-rated box can be used for such systems. See [Appendix A](#) for details on the configuration and wiring diagram.

Battery Only

With IQ Battery 5P

The IQ Battery will store energy from the grid at lower rates and deliver it to loads when grid tariffs are higher. IQ Battery cannot export energy back to the grid.

With IQ Combiner 5/5C

Figure 4: Battery Only grid-tied configuration with IQ Battery 5P and IQ Combiner 5C

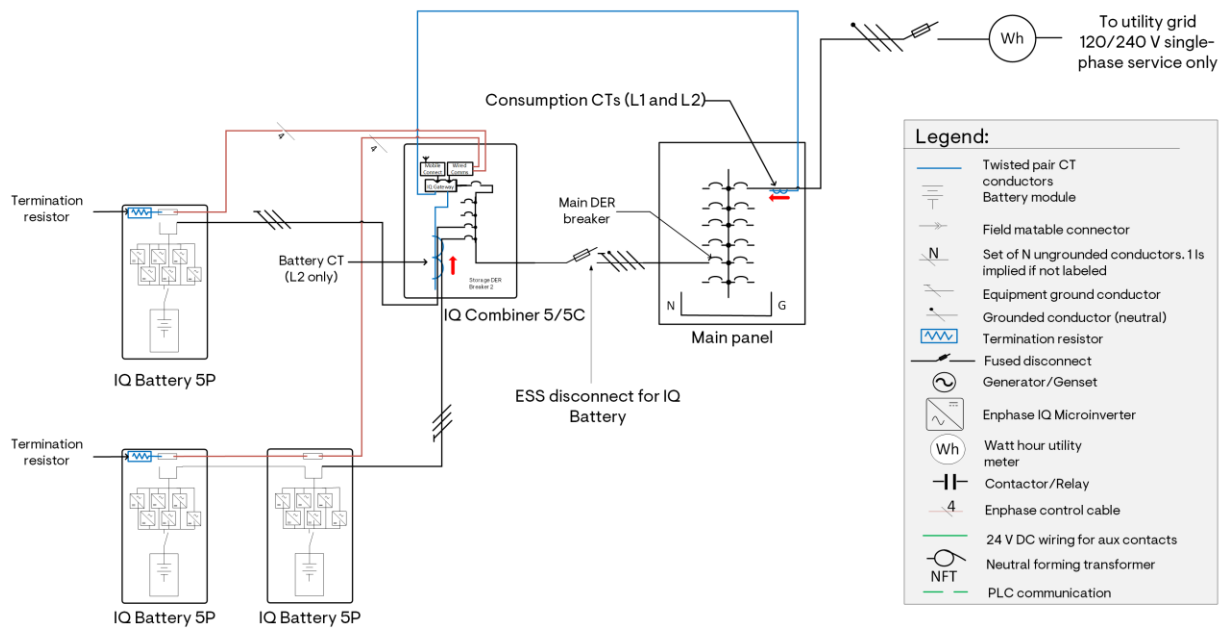

NOTES:

- IQ Combiner 5/5C can support DER breakers totaling up to 80 A. Each breaker slot on the combiner can accommodate a breaker rating of up to 60 A.
- On the IQ Combiner 5/5C, the system supports Power Control Systems (PCS) for battery oversubscription on one breaker. By limiting the continuous current from the battery branch, battery oversubscription can double the battery storage capacity that can be connected to that breaker.
- Instead of IQ Combiner 5/5C, an off-the-shelf sub-panel can be used for higher storage capacity. Refer to the [figure in Appendix](#).
- The Battery Current Transformer (CT) must clamp L2 conductors on both IQ Battery 5P branches if there are two or more battery circuits landing in the combiner.
- To make it easier to add battery backup functionality in the future, design the system with enough space in the installation area for an IQ System Controller 3/3G and an IQ Battery 5P.
- Main DER breaker (aggregate DER breaker on the main panel) can act as the ESS disconnecting means in grid-tied configuration if readily accessible.
- Any system with an IQ Battery 5P must have Wi-Fi or Ethernet as the primary mode of internet connectivity and an Enphase Mobile Connect as a backup mode of internet connectivity.

With IQ Gateway and Communications Kit 2

IQ Battery 5P can also be paired with an off-the-shelf sub-panel, Enphase IQ Gateway, Enphase Communications Kit 2 (COMMS-KIT-02), and Enphase Mobile Connect.

Figure 5: Battery Only grid-tied configuration IQ Battery 5P, COMMS-KIT-02, and IQ Gateway

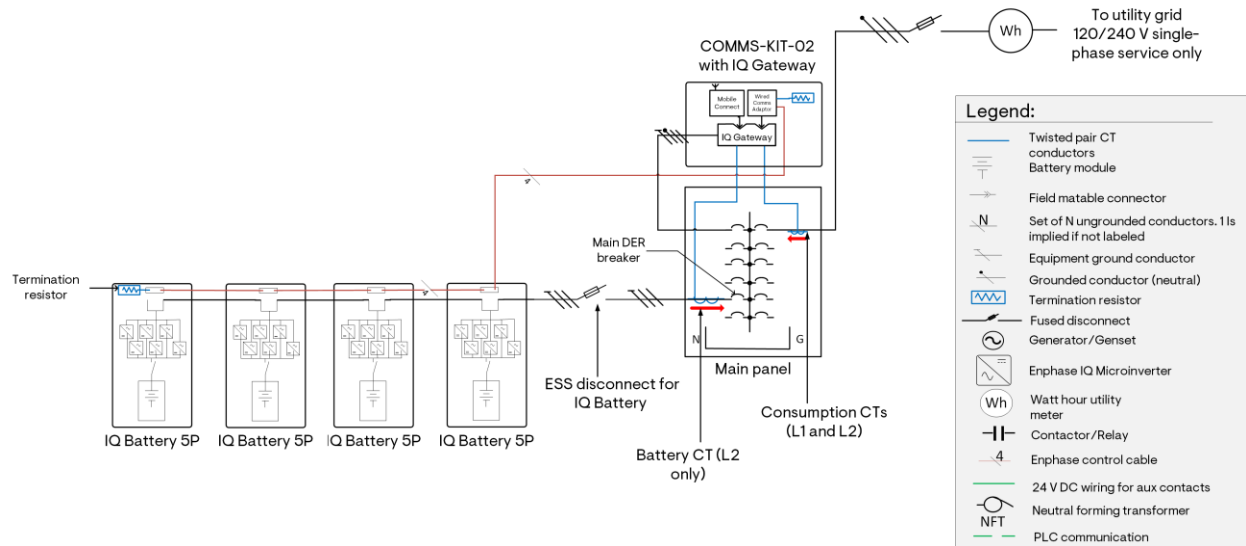

NOTES:

- Up to 16 IQ Battery 5P can be installed in a system.
- Use the power jumper provided with the Communications Kit 2 (COMMS KIT 02) to short the L2 and L3 terminals (marked “L2” and “X,” respectively) on the power terminal block in the IQ Gateway.
- Grid-tied Battery only systems with IQ Battery 5P require an IQ Gateway with software version 8.X or later.
- DER breaker on the main panel can act as the rapid shutdown initiator for ESS disconnecting means in grid-tied configuration if the main panel is readily accessible.
- Any system with an IQ Battery 5P must have Wi-Fi or Ethernet as the primary mode of internet connectivity and an Enphase Mobile Connect as a backup mode of internet connectivity.
- IQ Gateway and Enphase Mobile Connect must be purchased separately from the Enphase COMMS-KIT-02.
- To make it easier to add battery backup functionality in the future, design the system with enough space in the installation area for an IQ System Controller 3/3G and an IQ Battery 5P.



NOTE: An off-the-shelf sub-panel can be used if the battery array needs more than one breaker slot on the main panel due to installation-specific requirements or if the battery array is more than 40 kWh. See [Appendix A](#) for the configuration and wiring diagram.

With IQ Battery 3T/10T

In grid-tied Battery only configuration, IQ Battery 3/3T/10/10T can be paired with an IQ Combiner 4/4C. IQ Combiner 4/4C can accommodate up to 12 IQ Battery 3/3T or 4 IQ Battery 10/10T. IQ Battery 3T/10T does **not** support the Battery Oversubscription Power Control System (PCS) feature.

With IQ Combiner 4/4C

Figure 6: Battery Only grid-tied configuration with IQ Battery 3/3T/10/10T and IQ Combiner 4/4C

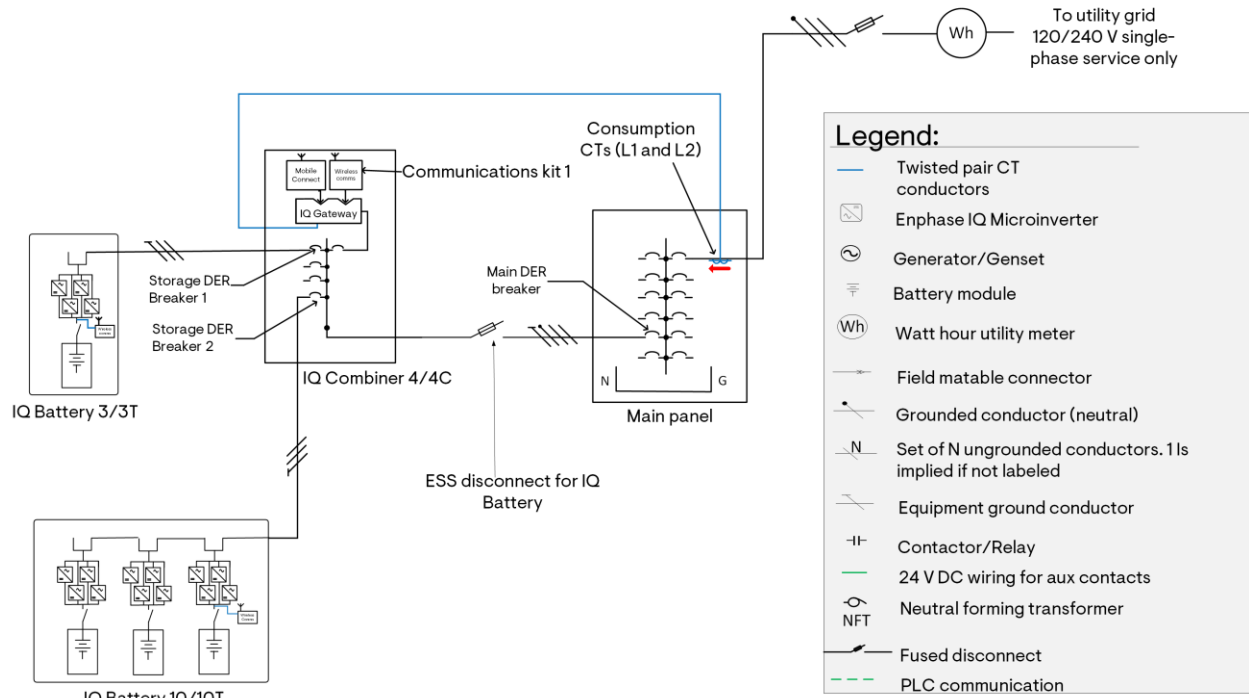

NOTES:

- IQ Combiner 4/4C can accommodate up to 12 IQ Battery 3/3T or 4 IQ Battery 10/10T. Each battery circuit can accommodate up to six IQ Battery 3/3T or 2 IQ Battery 10/10T. As a result, the maximum breaker sizing for a battery circuit is 40 A.
- Grid-tied Battery only systems with IQ Battery 3/3T/10/10T require an IQ Gateway (formerly IQ Envoy) software version 7.x or later.
- The main DER breaker (aggregate DER breaker on the main panel) can act as the rapid shutdown initiator for ESS disconnecting means in grid-tied configuration if readily accessible.
- Any system with an IQ Battery 3/3T/10/10T must have Wi-Fi or Ethernet as the primary mode of internet connectivity and an Enphase Mobile Connect as a backup mode of internet connectivity.

Using IQ Gateway and Communications Kit 1

Figure 7: Battery only grid-tied configuration with IQ Battery 3/3T/10/10T, IQ Gateway, COMMS-KIT-01, and Enphase Mobile Connect

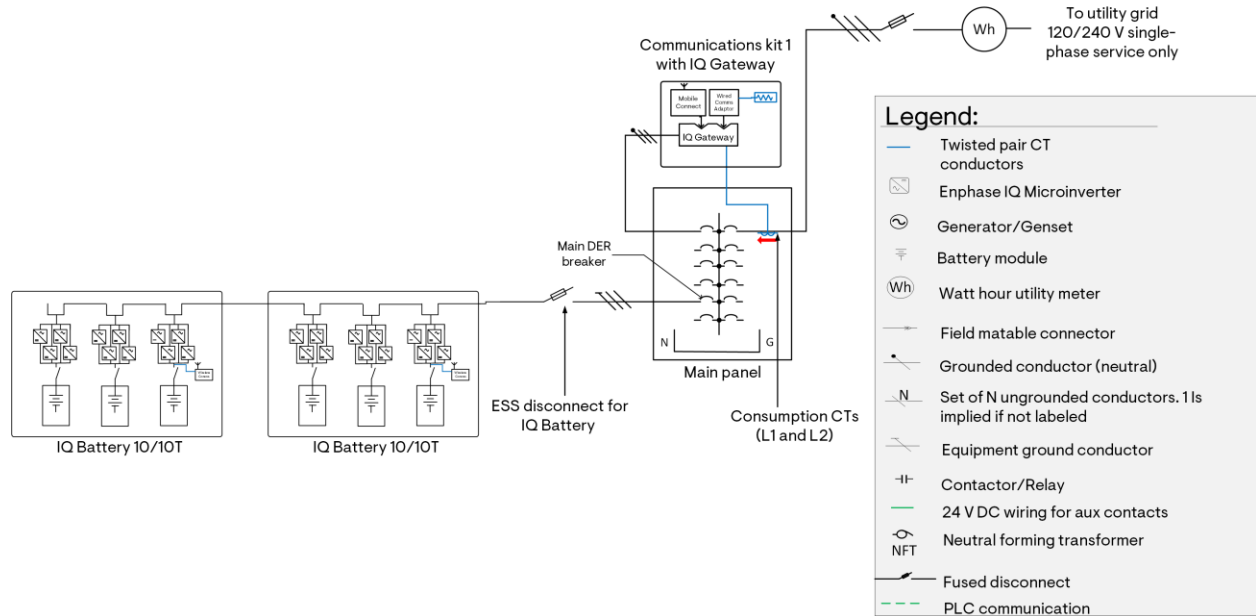

NOTES:

- Each battery circuit can accommodate up to six IQ Battery 3/3T or 2 IQ Battery 10/10T. As a result, the maximum breaker sizing for a battery circuit is 40 A.
- The maximum battery array size for a system using IQ Battery 3/3T/10/10T is 40 kWh.
- Grid-tied Battery Only systems with IQ Battery 3/3T/10/10T require an IQ Gateway software version 7. x or later.
- The main DER Breaker can act as the rapid shutdown initiator for ESS disconnecting means in grid-tied configuration if readily accessible.
- Any system with an IQ Battery 3/3T/10/10T must have Wi-Fi or Ethernet as the primary mode of internet connectivity and an Enphase Mobile Connect as a backup mode of internet connectivity.

Solar + Battery

Excess energy generated by Enphase microinverters can be exported to the grid. The IQ Battery will store energy generated by microinverters or energy from the grid at lower rates and deliver it to loads when grid tariffs are higher. IQ Battery cannot export energy back to the grid.

With IQ Battery 5P

With IQ Series Microinverters and IQ Combiner 5/5C

Figure 8: The Solar + Battery grid-tied configuration with IQ Combiner 5C, IQ8 or IQ7/6 Series Microinverters and IQ Battery 5P

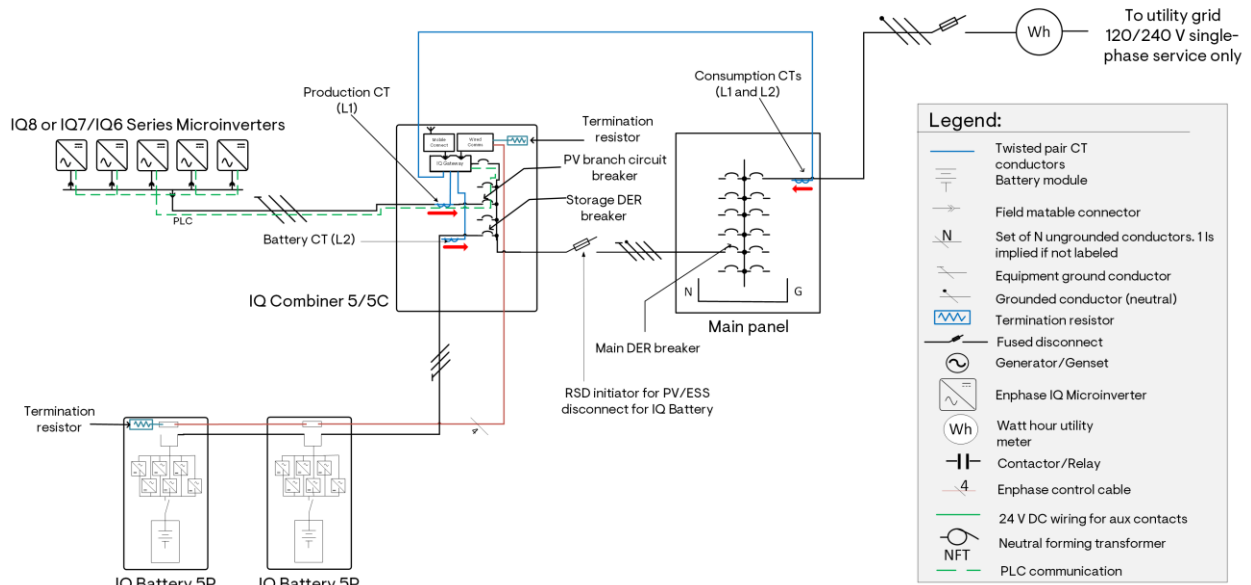

NOTES:

- IQ8 Series Microinverters cannot be mixed with other Enphase microinverters as they are incompatible with older generations of Enphase microinverters, including IQ6 and IQ7 Series Microinverters. This applies to all system configurations, with and without storage.
- The sum of the microinverter and IQ Battery circuit-rated continuous currents must not exceed 64 A.
- IQ Combiner 5/5C can support DER breakers totaling up to 80 A. Each breaker slot on the combiner can accommodate a breaker rating of up to 60 A.
- On the IQ Combiner 5/5C, the system supports Power Control Systems (PCS) for battery oversubscription on one breaker. By limiting the continuous current from the battery branch, battery oversubscription can double the battery storage capacity that can be connected to that breaker.
- Main Panel Upgrade Avoidance can be achieved by:
 - Divide the main panel breaker rating allowed between PV and Battery. For example, for a system with a 40 A DER breaker, assign 20 A for PV and 20 A for the battery. It is recommended to divide proportionately based on the original PV and battery nameplates.
 - Use the Main Panel Upgrade Avoidance for grid-tied PV feature in the Installer app to configure the breaker size to match the part of the DER breaker allocated for PV. In the example, this is 20 A breaker size and 16 A continuous.
 - Use the IQ Battery Oversubscription feature in the Installer app to achieve Main Panel Upgrade Avoidance for the grid-tied battery to configure the breaker size to match the part of the DER breaker allocated for the battery. In the example, this is 20 A breaker size and 16 A continuous.

- In this Main Panel Upgrade Avoidance implementation, the battery and PV are limited to their respective limits. Even when PV is not producing (say, at night), the battery cannot exceed its limit, and vice versa.
- Enphase is developing a more efficient PCS implementation for this configuration, which will be available soon.
- Systems with IQ Battery 5P require IQ Gateway software version 8.X or later. If an update is needed, it will be automatically applied during the commissioning process.
- The main DER breaker (aggregate DER breaker on the main panel) can act as the rapid shutdown initiator for PV and ESS disconnecting means in grid-tied configuration if the main panel is readily accessible.
- Any system with an IQ Battery 5P must have Wi-Fi or Ethernet as the primary mode of internet connectivity and an Enphase Mobile Connect as a backup mode of internet connectivity.



NOTE: If the sum of the rated continuous currents of PV branches and IQ Battery 5P branch is greater than 64 A, an IQ Combiner 5/5C cannot be used to aggregate all PV branch circuits. An appropriately sized, off-the-shelf DER sub-panel and a standalone IQ Gateway in a NEMA 3R or higher-rated box can be used for such systems. However, Battery Oversubscription PCS is not available in this configuration right now. See [Appendix A](#) for the configuration and wiring diagram.

With IQ Series Microinverters and IQ Combiner 4/4C

IQ Combiner 4C can be paired with COMMS-KIT-02 to support IQ8/IQ7/IQ6 Series Microinverters and IQ Battery 5P in Solar + Battery grid-tied configuration. The sum of maximum current from PV branches and Battery branches should not exceed 80 A—IQ Combiner 4C supports DER breakers totaling up to 80 A.

Figure 9: The Solar + Battery grid-tied configuration with IQ Combiner 4C, IQ8/7/6 Series Microinverters and IQ Battery 5P

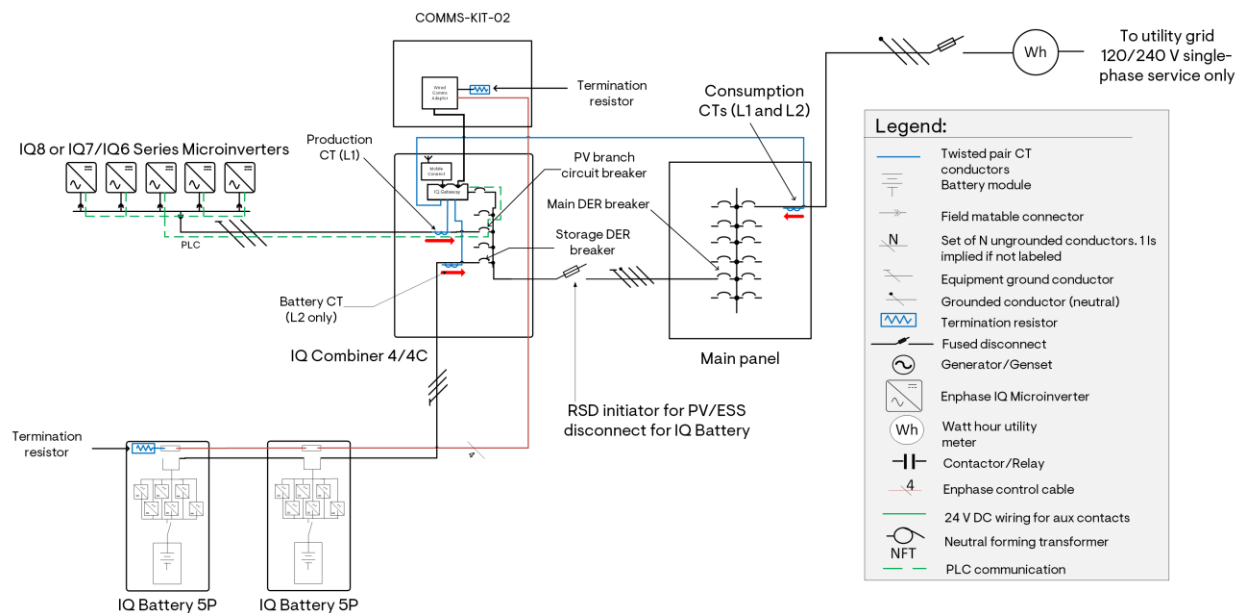

NOTES:

- IQ8 Series Microinverters are incompatible with previous generations of Enphase microinverters, such as IQ6, IQ7, and M Series Microinverters, and cannot be installed together. This holds for all system configurations, both with and without storage.
- The sum of the microinverter and IQ Battery circuit-rated continuous currents must not exceed 64 A.
- IQ Combiner 4/4C can support DER breakers totaling up to 80 A. Each breaker slot on the combiner can accommodate a breaker rating of up to 60 A.
- Battery Oversubscription PCS is not available with IQ Combiner 4/4C currently.
- Use the power jumper provided with the Communications Kit 2 (COMMS KIT 02) to short the L2 and L3 terminals (marked “L2” and “X,” respectively) on the power terminal block in the IQ Gateway.
- Systems with IQ Battery 5P require IQ Gateway software version 8. X or later. If an update is needed, it will be automatically applied during the commissioning process.
- The aggregate DER breaker on the main panel can act as the rapid shutdown initiator for PV and ESS disconnecting means in grid-tied configuration if the main panel is readily accessible.
- Any system with an IQ Battery 5P must have Wi-Fi or Ethernet as the primary mode of internet connectivity and an Enphase Mobile Connect as a backup mode of internet connectivity.



NOTE: If the sum of the rated continuous currents of PV branches and IQ Battery 5P branch is greater than 64 A, an IQ Combiner 4/4C cannot be used to aggregate all PV branch circuits. An appropriately sized, off-the-shelf DER sub-panel and a standalone IQ Gateway in a NEMA 3R or higher-rated box can be used for such systems. See [Appendix A](#) for the configuration and wiring diagram.

With M Series Microinverters, Envoy S Metered and COMMS-KIT-02

Figure 10: The Solar + Battery grid-tied configuration with M Series Microinverters, IQ Battery 5P, Envoy S Metered, Enphase COMMS-KIT-02, Enphase Mobile Connect, and third-party combiner box

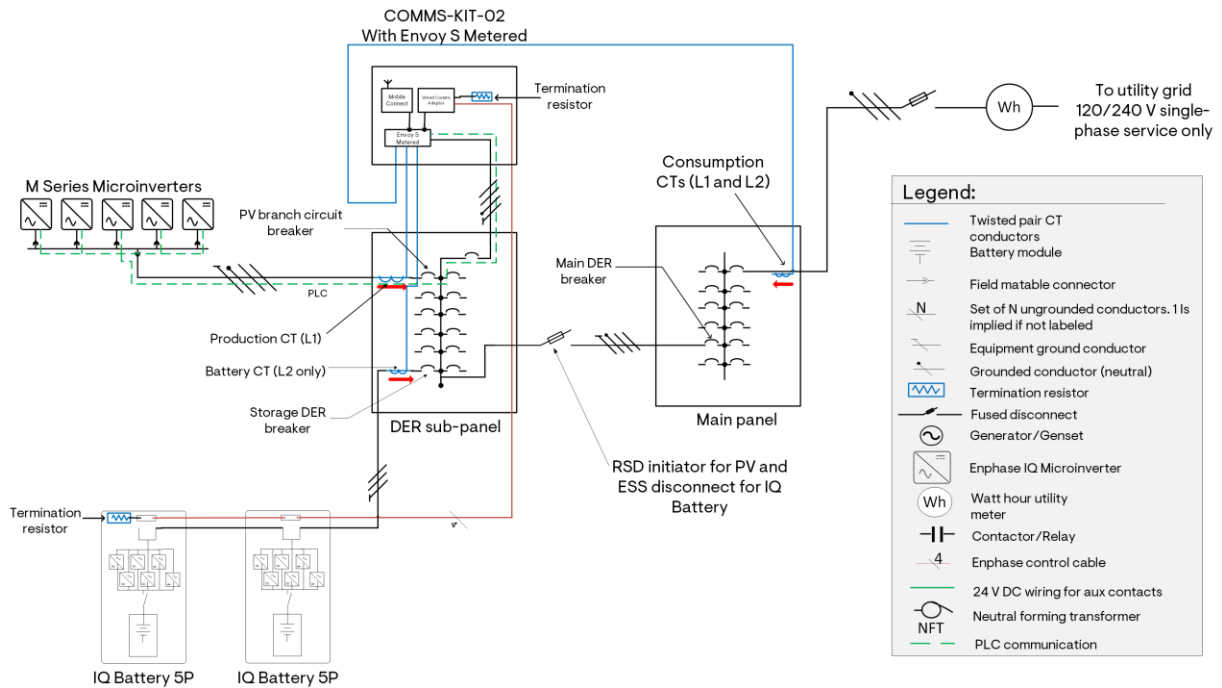

NOTES:

- Enphase COMMS-KIT-02 and Enphase Mobile Connect can be added to existing M Series Microinverters to enable IQ Battery 5P installation.
- M Series Microinverters are incompatible with newer IQ8 or IQ6/IQ7 Microinverters. This applies to all system configurations with and without storage.
- Up to 16 IQ Battery 5P (80 kWh) can be installed in a system.
- Use a jumper cable to connect the L2 and L3 terminals in the Envoy S Metered power terminal block. These terminals are marked “B” and “C” respectively.
- Systems with IQ Battery 5P require IQ Gateway software version 8. X or later. If an update is needed, it will be automatically applied during the commissioning process.
- DER sub-panel breaker (main DER breaker) on the main panel can act as the rapid shutdown initiator for PV and ESS disconnecting means in grid-tied configuration if the main panel is readily accessible.
- The Mobile Connect cell modem has to be purchased separately from COMMS-KIT-02.
- Any system with an IQ Battery 5P must have Wi-Fi or Ethernet as the primary mode of internet connectivity and an Enphase Mobile Connect as a backup mode of internet connectivity.

With IQ Battery 3T/10T

With IQ Series Microinverters and IQ Combiner 4/4C

Figure 11: Solar + Battery grid-tied configuration with IQ Battery 3T/10T and IQ Combiner 4C

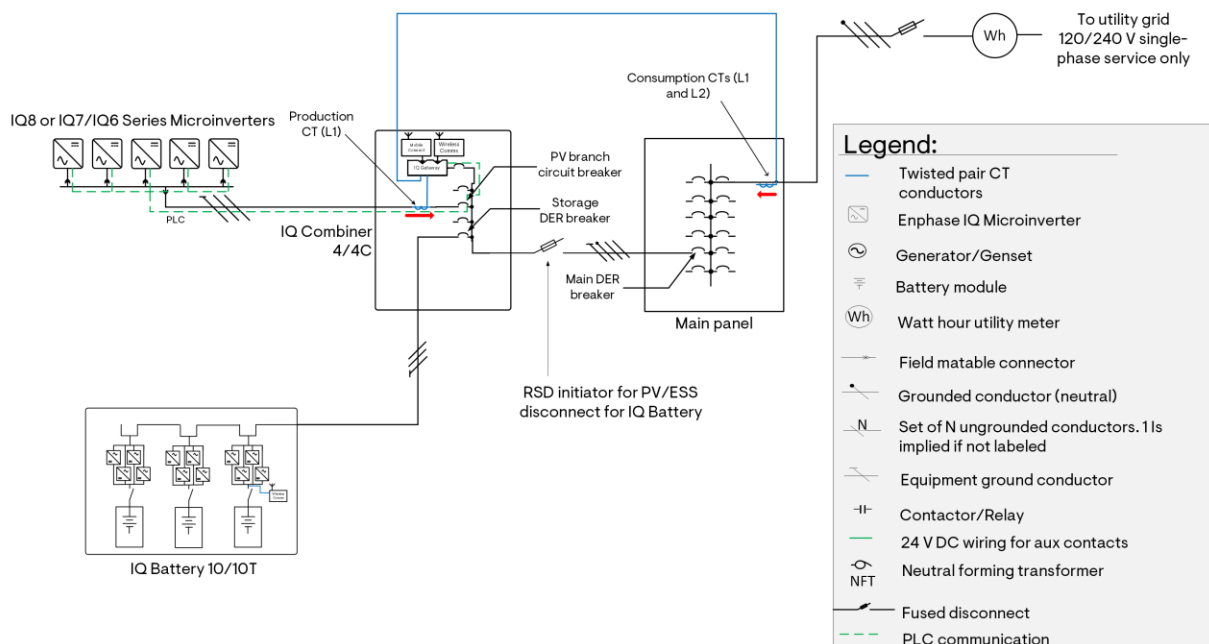

NOTES:

- IQ8 Series Microinverters are incompatible with previous generations of Enphase microinverters, such as IQ6, IQ7, and M Series Microinverters, and cannot be installed together. This holds for all system configurations, both with and without storage.
- The sum of the microinverter and IQ Battery circuit-rated continuous currents must not exceed 64 A.
- Each battery circuit can accommodate up to six IQ Battery 3/3T or two IQ Battery 10/10T. As a result, the maximum breaker sizing for a battery circuit is 40 A.
- The maximum battery array size for a system using IQ Battery 3/3T/10/10T is 40 kWh.
- IQ Combiner 4/4C can support DER breakers totaling up to 80 A. Each breaker slot on the combiner can accommodate a breaker rating of up to 60 A.
- Battery Oversubscription PCS is not available with IQ Combiner 4/4C currently.
- The aggregate DER breaker on the main panel can act as the rapid shutdown initiator for PV and ESS disconnecting means in grid-tied configuration if the main panel is readily accessible.
- Any system with an IQ Battery 3/3T/10/10T must have Wi-Fi or Ethernet as the primary mode of internet connectivity and an Enphase Mobile Connect as a backup mode of internet connectivity.



NOTE: If the sum of the rated continuous currents of PV branches and IQ Battery 3T/10T branch is greater than 64 A, an IQ Combiner 4/4C cannot be used to aggregate all PV branch circuits. An appropriately sized, off-the-shelf PV sub-panel and a standalone IQ Gateway in a NEMA-3R or higher-rated box can be used for such systems. See [Appendix A](#) for the configuration and wiring diagram.

With M Series Microinverters, Envoy S Metered and COMMS-KIT-01

Figure 12: The Solar + Battery configuration with M Series, third-party combiner box, COMMS-KIT-01, and Enphase Mobile Connect Cell modem

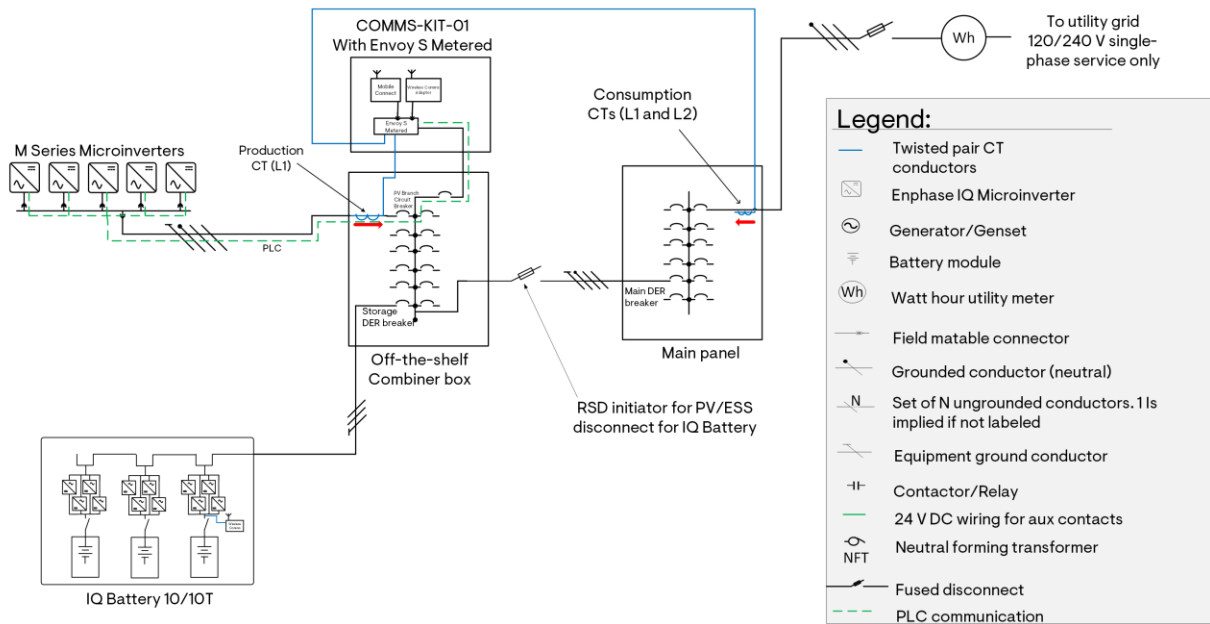

NOTES:

- Enphase COMMS-KIT-01 and Enphase Mobile Connect can be added to existing M Series Microinverters to enable IQ Battery 3/3T/10/10T installation.
- M Series Microinverters are incompatible with newer IQ8 or IQ6/IQ7 Microinverters. This applies to all system configurations with and without storage.
- Each battery circuit can accommodate up to six IQ Battery 3/3T or two IQ Battery 10/10T. As a result, the maximum breaker sizing for a battery circuit is 40 A.
- The maximum battery array size for a system using IQ Battery 3/3T/10/10T is 40 kWh.
- The main DER breaker on the main panel can act as the rapid shutdown initiator for PV and ESS disconnecting means in grid-tied configuration if the main panel is readily accessible.
- Any system with an IQ Battery 3/3T/10/10T must have Wi-Fi or Ethernet as the primary mode of internet connectivity and an Enphase Mobile Connect as a backup mode of internet connectivity.

Grid-forming (with backup) system configurations

Solar Only

Sunlight Backup (partial home backup)

Sunlight Backup or Solar Only grid-forming systems can run essential loads during a grid outage.

With IQ System Controller 3

Figure 13: Sunlight Backup configuration with IQ System Controller 3 in partial home backup configuration

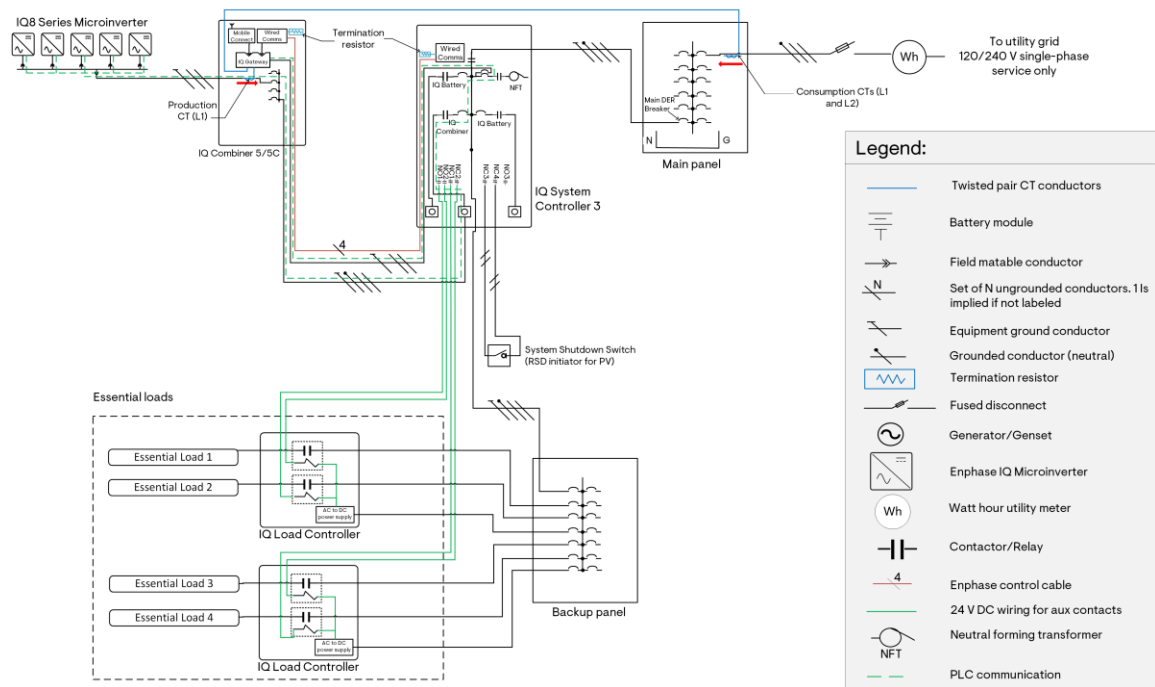

NOTES:

1. This configuration is only supported by IQ8 Series Microinverters.
2. The system supplies power only when the sun is shining
3. The system can support PV branch circuits with continuous current output ratings of up to 64 A.
4. This configuration requires the use of an essential loads solution. An essential loads solution consists of the following:
 - a. An off-the-shelf panel with a maximum of four pre-selected, essential load circuits backed up by the system.
 - b. Up to two IQ Load Controllers, each enabling fine-grained, circuit-level control for two 240 V or four 120 V essential load circuits. Sunlight Backup needs at least one IQ Load Controller to be installed on-site.
5. Whole home backup using this configuration is not supported, as it will result in a bad customer experience.

Refer to [Understanding sunlight backup system installers and system designers](#) tech brief for system installation and commissioning details.

With IQ System Controller 3G

Figure 14: Sunlight Backup configuration with IQ System Controller 3G and Generator in partial home backup configuration

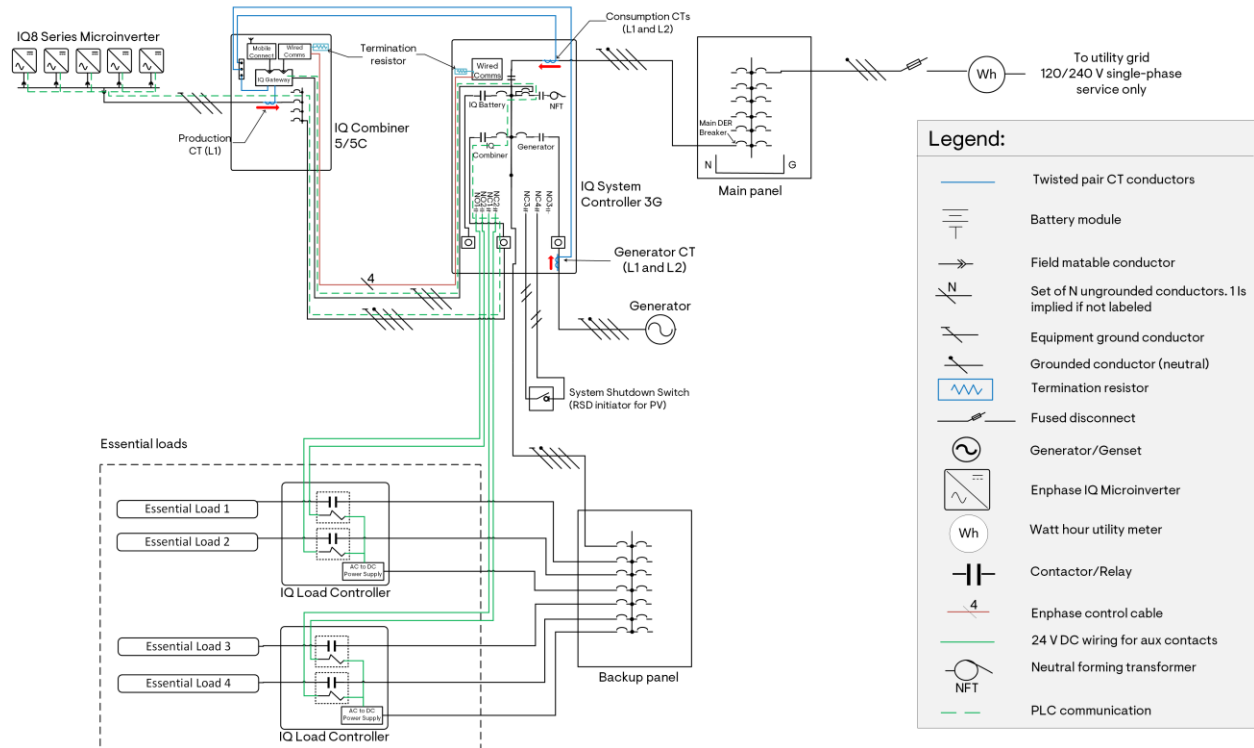

NOTES:

1. This configuration is only supported by IQ8 Series Microinverters.
2. The system supplies power only when the sun is shining.
3. The rated continuous power output of the generator must be at least equal to the rated continuous power out of the generator. Refer to the [Generator sizing](#) section for more details. If the microinverter array exceeds this ratio, use PV shedding to drop the excess PV circuits when the system transitions to off-grid mode.
4. Heavier loads can be configured to run in off-grid only when the generator is operating by connecting them to the IQ Load Controller.
5. The system can support PV branch circuits with continuous current output ratings of up to 64 A.
6. This configuration requires the use of an Essential Loads Solution. An Essential Loads Solution consists of the following:
 - a. An off-the-shelf panel with a maximum of four pre-selected, essential load circuits backed up by the system.

- b. Up to two IQ Load Controllers, each enabling fine-grained, circuit-level control for two 240 V or four 120 V essential load circuits. Sunlight Backup needs at least one IQ Load Controller to be installed on-site.
- 7. Whole home backup using this configuration is not supported, as it will result in a bad customer experience.

Refer to [Understanding sunlight backup system installers and system designers](#) tech brief for system installation and commissioning details.

With IQ System Controller 2

Figure 15: Sunlight Backup configuration with IQ System Controller 2 in partial home backup configuration

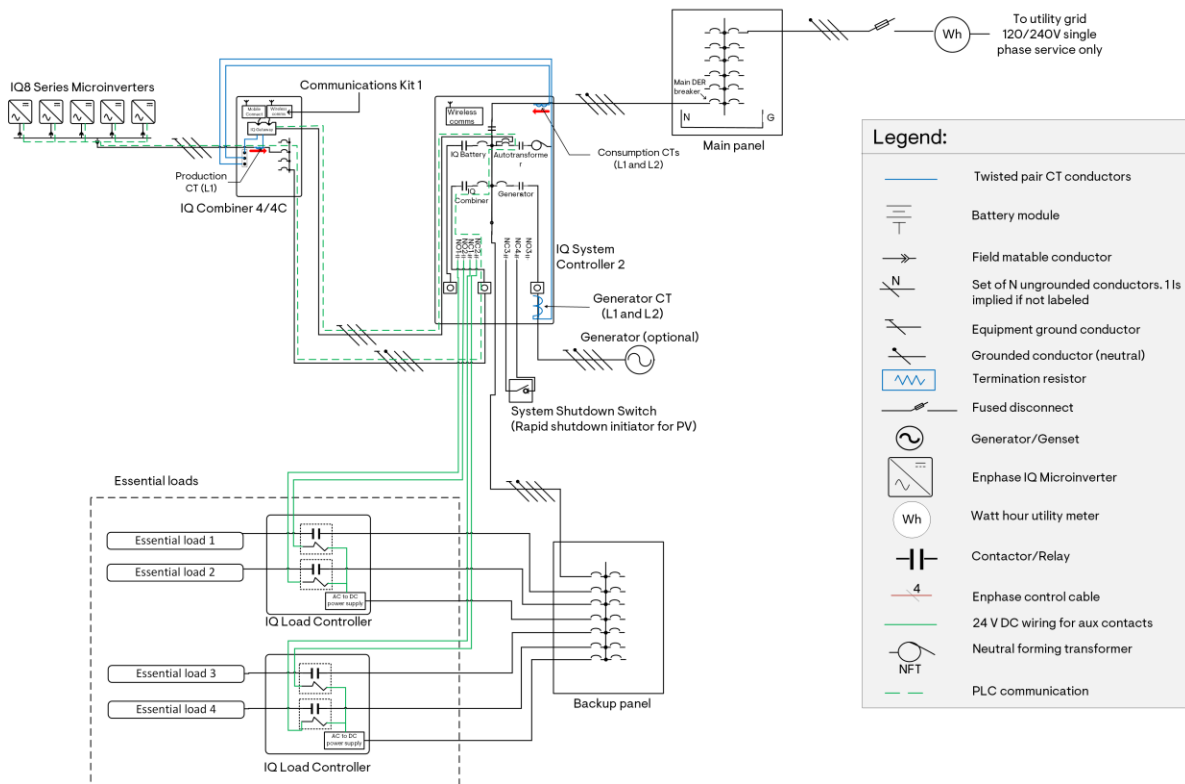

NOTES:

1. This configuration is only supported by IQ8 Series Microinverters.
2. The system supplies power only when the sun is shining.
3. In the case of a system with a generator, the rated continuous power output of the generator must be at least equal to the rated continuous power out of the generator. Refer to the [Generator sizing](#) section for more details. If the microinverter array exceeds this ratio, use PV shedding to drop the excess PV circuits when the system transitions to off-grid mode.
4. Heavier loads can be configured to run off-grid only when the generator is operating by connecting them to the IQ Load Controller.
5. The system can support PV branch circuits with continuous current output ratings of up to 64 A.
6. This configuration requires the use of an essential loads solution. An essential loads solution consists of the following:

- a. An off-the-shelf panel with a maximum of four pre-selected, essential load circuits backed up by the system.
 - b. Up to two IQ Load Controllers, each enabling fine-grained, circuit-level control for two 240 V or four 120 V essential load circuits. Sunlight Backup needs at least one IQ Load Controller to be installed on-site.
7. Whole home backup using this configuration is not supported, as it will result in a bad customer experience.

Refer to [Understanding sunlight backup system installers and system designers](#) tech brief for system installation and commissioning details.

Battery Only

Battery Only grid-forming systems will store energy from the grid and supports the home load during high tariff periods or a grid outage.

Whole home backup

This configuration provides backup for all loads in a home at all times of day and night. The battery array must be appropriately sized to supply the loads. Depending on the size of the IQ Battery array, the system will be able to operate off-grid for extended periods. Up to two IQ Load Controllers can be used for circuit-level load control of backed-up loads.

Without generator

With IQ Battery 5P and IQ System Controller 3

Figure 16: Battery Only grid-forming whole home backup configuration with IQ Battery 5P and IQ System Controller 3

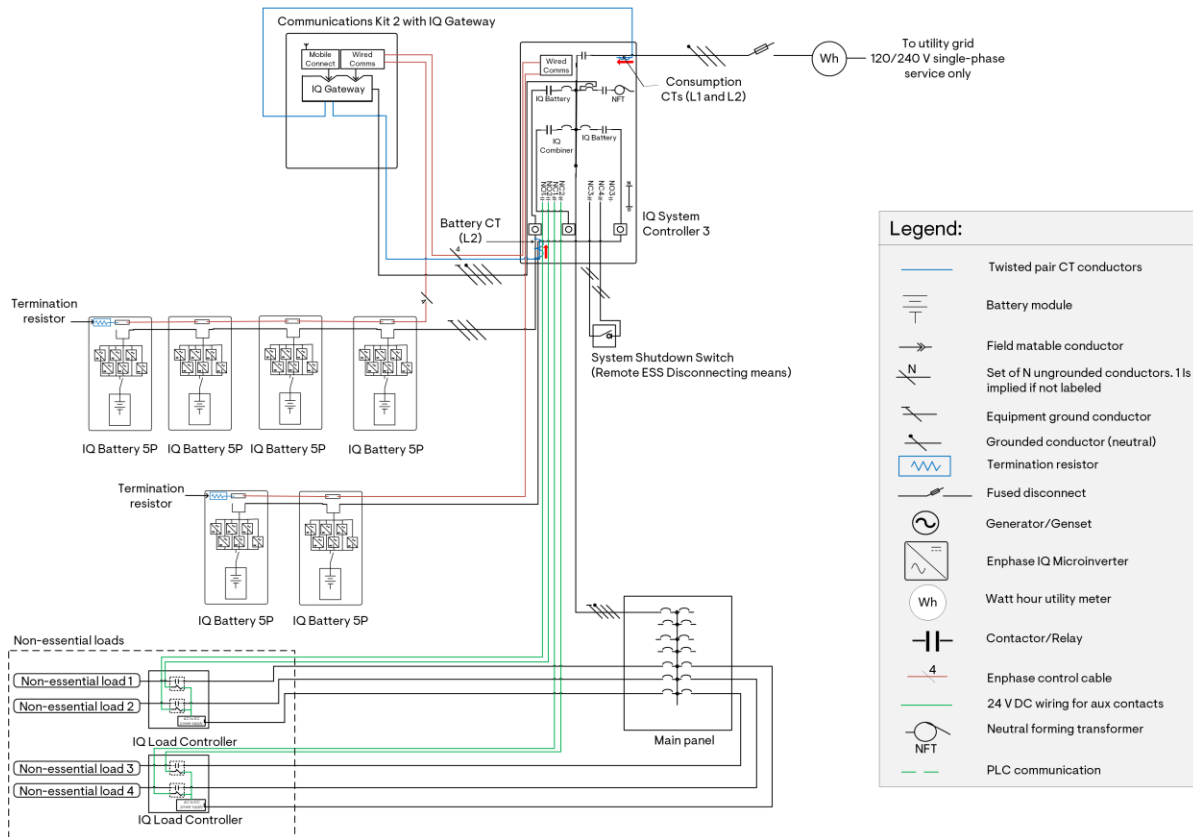

NOTES:

1. The power control system for Battery Oversubscription support for systems using IQ Gateway and older generation IQ Combiners are being evaluated. In the meantime, IQ Combiner 5/5C can be used instead of the IQ Gateway and Communications Kit 2 to enable Battery Oversubscription and install up to 80 kWh, i.e., 16 IQ Battery 5P.
2. Self-Consumption battery mode is not available in battery-only configurations. Savings and Full backup modes are available and can be accessed using the settings in the Enphase Installer App or Enphase App. Refer to the [System profiles](#) section for details on system behavior in these modes.
3. IQ Gateway and a Mobile Connect cellular modem must be ordered separately from COMMS-KIT-02.
4. The System Shutdown Switch can be used as a remote ESS disconnecting means where required.
5. Any system with an IQ Battery 3/3T/10/10T must have Wi-Fi or Ethernet as the primary mode of internet connectivity and an Enphase Mobile Connect as a backup mode of internet connectivity.

With IQ Battery 3/3T/10/10T and IQ System Controller 2

Figure 17: Battery Only grid-forming whole home backup configuration with IQ Battery 3/3T/10/10T and IQ System Controller 2

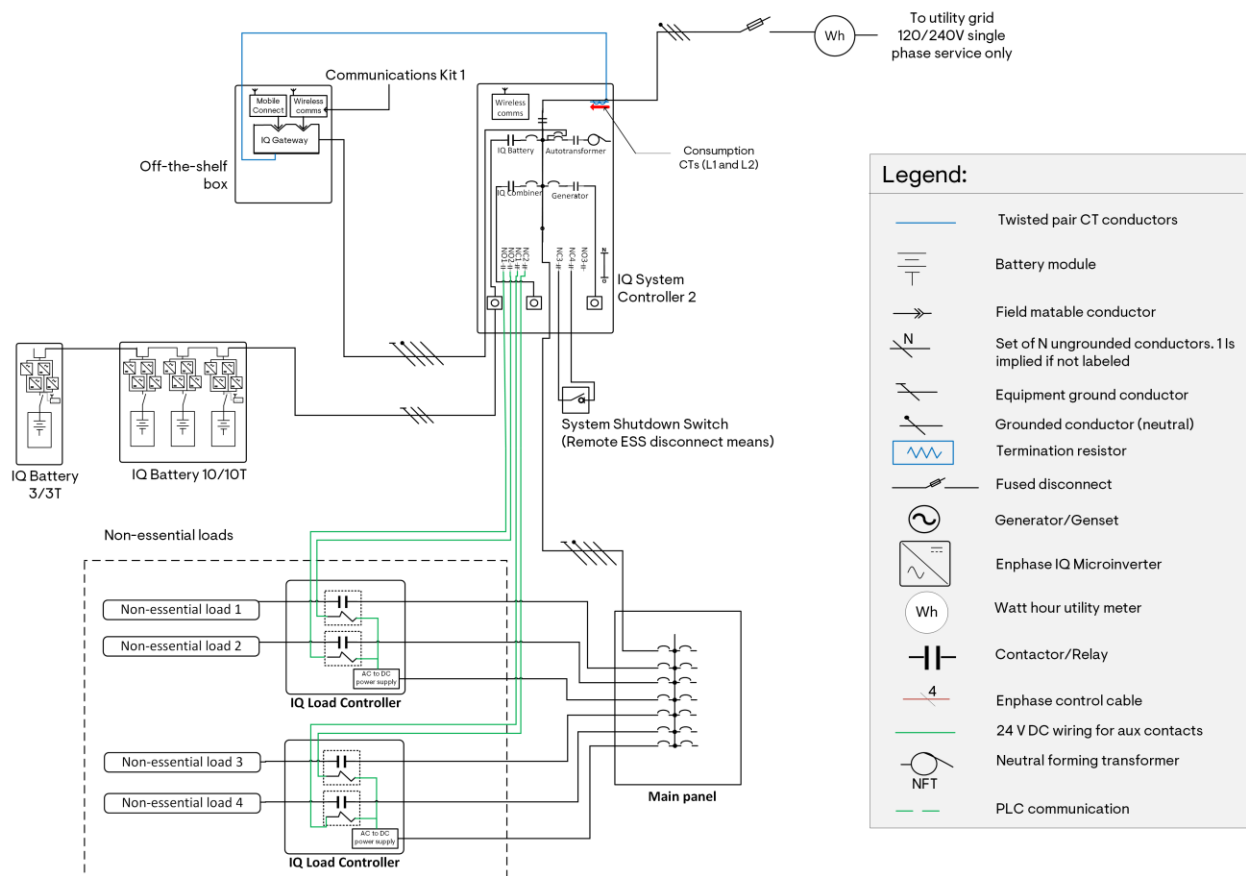

NOTES:

1. EES systems using IQ System Controller 2 and IQ Battery 3/3T/10/10T do not support the Battery Oversubscription feature and can only support battery storage up to 40 kWh.

- Self-Consumption battery mode is not available in Battery Only configurations. Savings and Full Backup modes are available and can be accessed using the settings in the Enphase Installer App or Enphase App. Refer to the [System profiles](#) section for details on system behavior in these modes.
- The System Shutdown Switch can be used as a remote ESS disconnecting means where required.
- Any system with an IQ Battery 3/3T/10/10T must have Wi-Fi or Ethernet as the primary mode of internet connectivity and an Enphase Mobile Connect as a backup mode of internet connectivity.

With generator

With IQ Battery 5P and IQ System Controller 3G

Figure 18: Battery Only grid-forming whole home backup configuration with IQ Battery 5P and IQ System Controller 3G

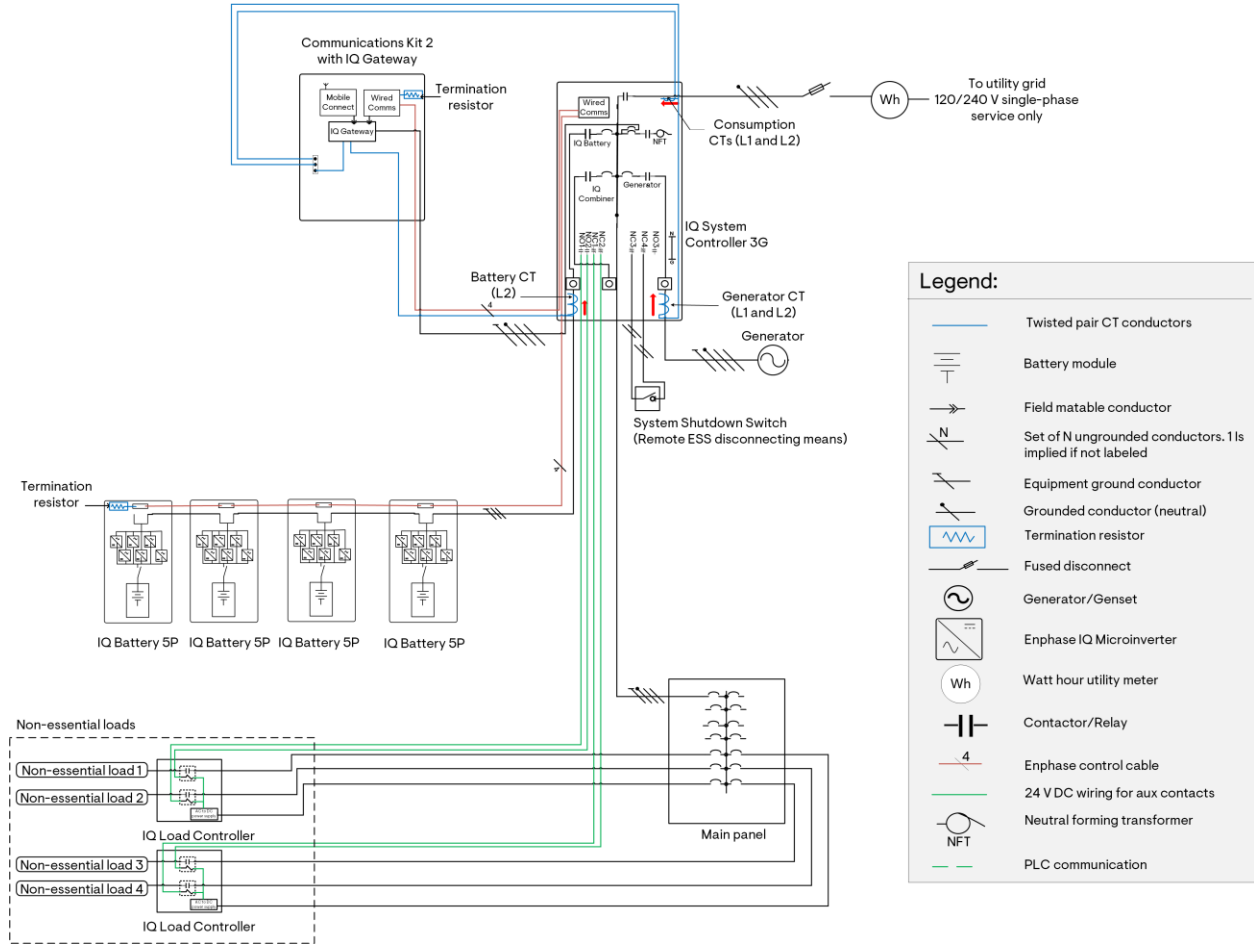

NOTES:

- The power control system for Battery Oversubscription support for systems using IQ Gateway and older generation IQ Combiners is being evaluated. In the meantime, IQ Combiner 5/5C can be used instead of the IQ Gateway and Communications Kit 2 to enable Battery Oversubscription and install up to 40 kWh, i.e., eight IQ Battery 5Ps.
- Self-Consumption battery mode is not available in Battery Only configurations. Savings and Full Backup modes are available and can be accessed using the settings in the Enphase Installer App or Enphase App. Refer to the [System profiles](#) section for details on system behavior in these modes.
- IQ Gateway and a Mobile Connect cellular modem must be ordered separately from COMMS-KIT-02.

4. The System Shutdown Switch can be used as a remote ESS disconnecting means where required.
5. The generator power rating must be at least 143% of the IQ Battery array continuous power rating. Refer to the [Generator sizing](#) section for details.
6. Refer to the [Generator tech brief](#) for details on supported generator makes and additional installation requirements.
7. Any system with an IQ Battery 5P must have Wi-Fi or Ethernet as the primary mode of internet connectivity and an Enphase Mobile Connect as a backup mode of internet connectivity.
8. Figure 18 does not show a remote start for the generator. Refer to [Appendix B](#) for details.

With IQ Battery 3/3T/10/10T and IQ System Controller 2

Figure 19: Battery Only grid-forming whole home backup configuration with IQ Battery 3/3T/10/10T and IQ System Controller 2

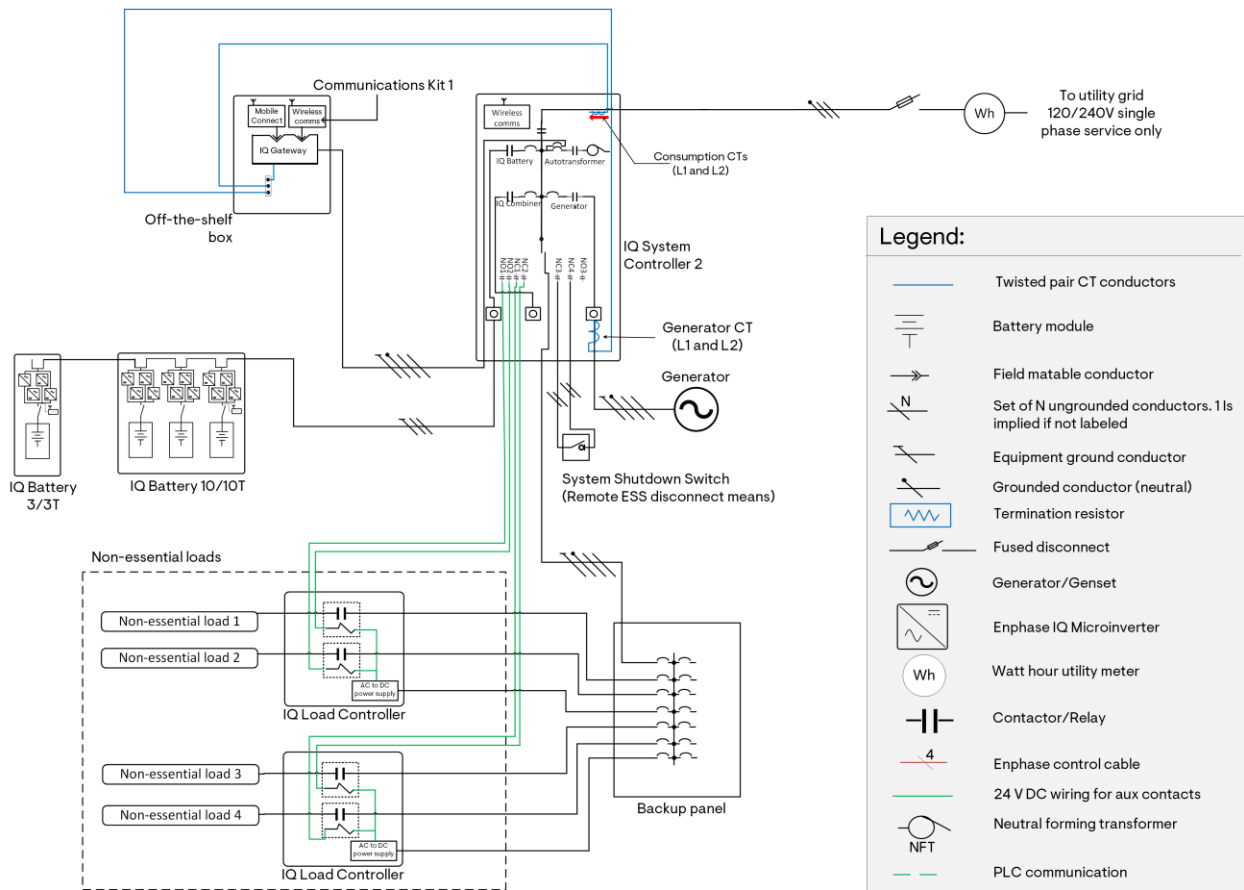

NOTES:

1. EES systems using IQ System Controller 2 and IQ Battery 3/3T/10/10T can support battery storage of up to 40 kWh.
2. Self-Consumption battery mode is not available in Battery Only configurations. Savings and Full Backup modes are available and can be accessed using the settings in the Enphase Installer App or Enphase App. Refer to the [System profiles](#) section for details on system behavior in these modes.
3. The System Shutdown Switch can be used as a remote ESS disconnecting means where required.

- The generator power rating must be at least 143% of the IQ Battery array continuous power rating. Refer to the [Generator sizing](#) section for details.
- Refer to the [Generator tech brief](#) for details on supported generator makes and additional installation requirements.
- Any system with an IQ Battery 3/3T/10/10T must have Wi-Fi or Ethernet as the primary mode of internet connectivity and an Enphase Mobile Connect as a backup mode of internet connectivity.
- The diagram does not show a remote start for the generator. Refer to [Appendix B](#) for details.

Partial home backup

In this configuration, essential loads are aggregated on a backup load panel. All the loads connected to the backup load panel will transition to off-grid seamlessly. It is strongly advised to use up to two IQ Load Controllers to eliminate heavy 240 V loads like HVACs, electric ovens, EV chargers, etc. when the system enters backup mode.

Without generator

With IQ Battery 5P and IQ System Controller 3

Figure 20: Battery Only grid-forming partial home backup configuration with IQ Battery 5P and IQ System Controller 3

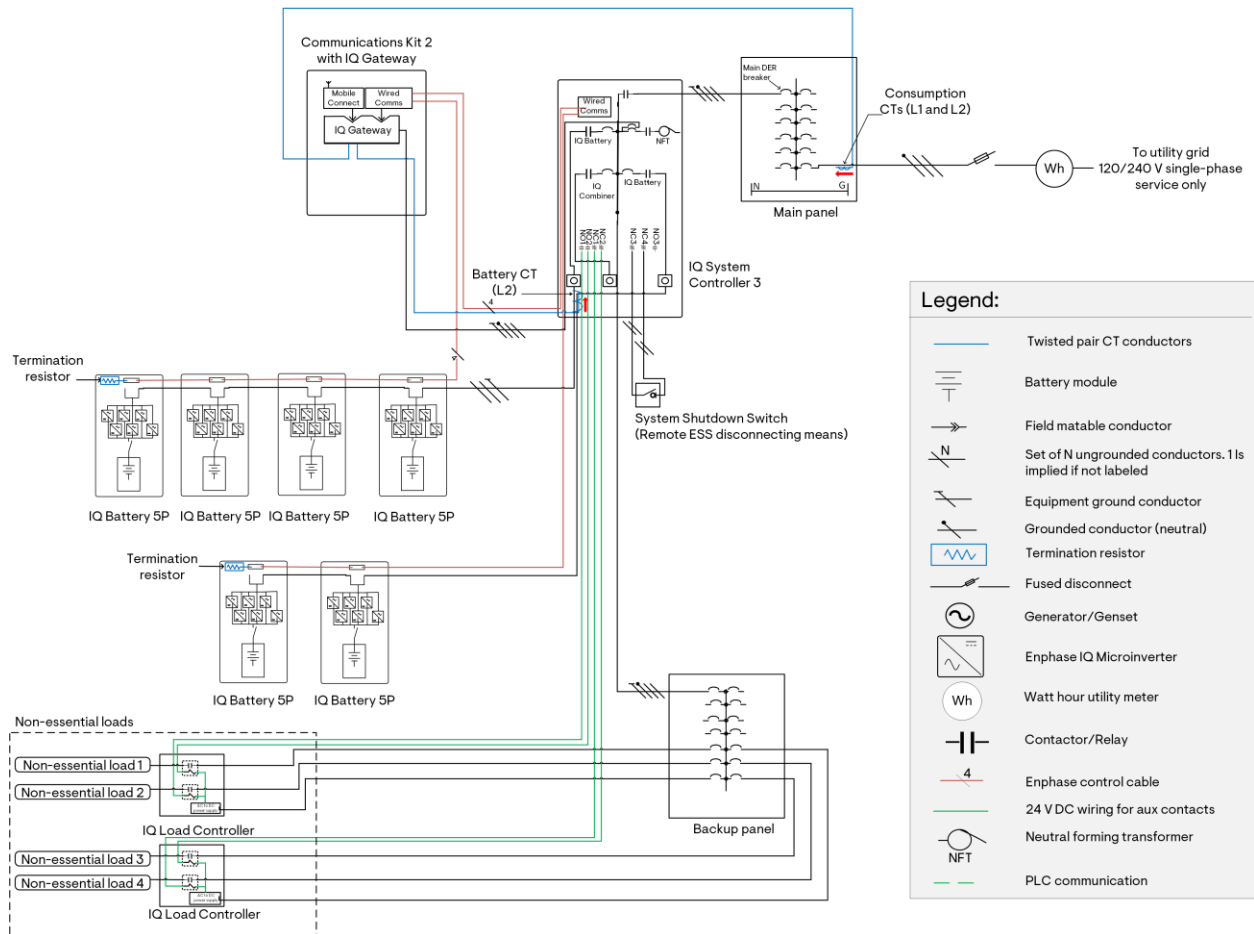

NOTES:

- The power control system for Battery Oversubscription feature support for systems using IQ Gateway and older generation IQ Combiners is being evaluated. In the meantime, IQ Combiner 5/5C can be used instead of the IQ Gateway and Communications Kit 2 to enable Battery Oversubscription and install up to 80 kWh, i.e., 16 IQ Battery 5P.

2. Self-Consumption battery mode is not available in Battery Only configurations. Savings and Full Backup modes are available and can be accessed using the settings in the Enphase Installer App or Enphase App. Refer to the [System profiles](#) section for details on system behavior in these modes.
3. IQ Gateway and a Mobile Connect cellular modem must be ordered separately from COMMS-KIT-02.
4. The System Shutdown Switch can be used as a remote ESS disconnecting means where required.
5. Any system with an IQ Battery 5P must have Wi-Fi or Ethernet as the primary mode of internet connectivity and an Enphase Mobile Connect as a backup mode of internet connectivity.

With IQ Battery 3/3T/10/10T and IQ System Controller 2

Figure 21: Battery Only grid-forming partial home backup configuration with IQ Battery 3/3T/10/10T and IQ System Controller 2

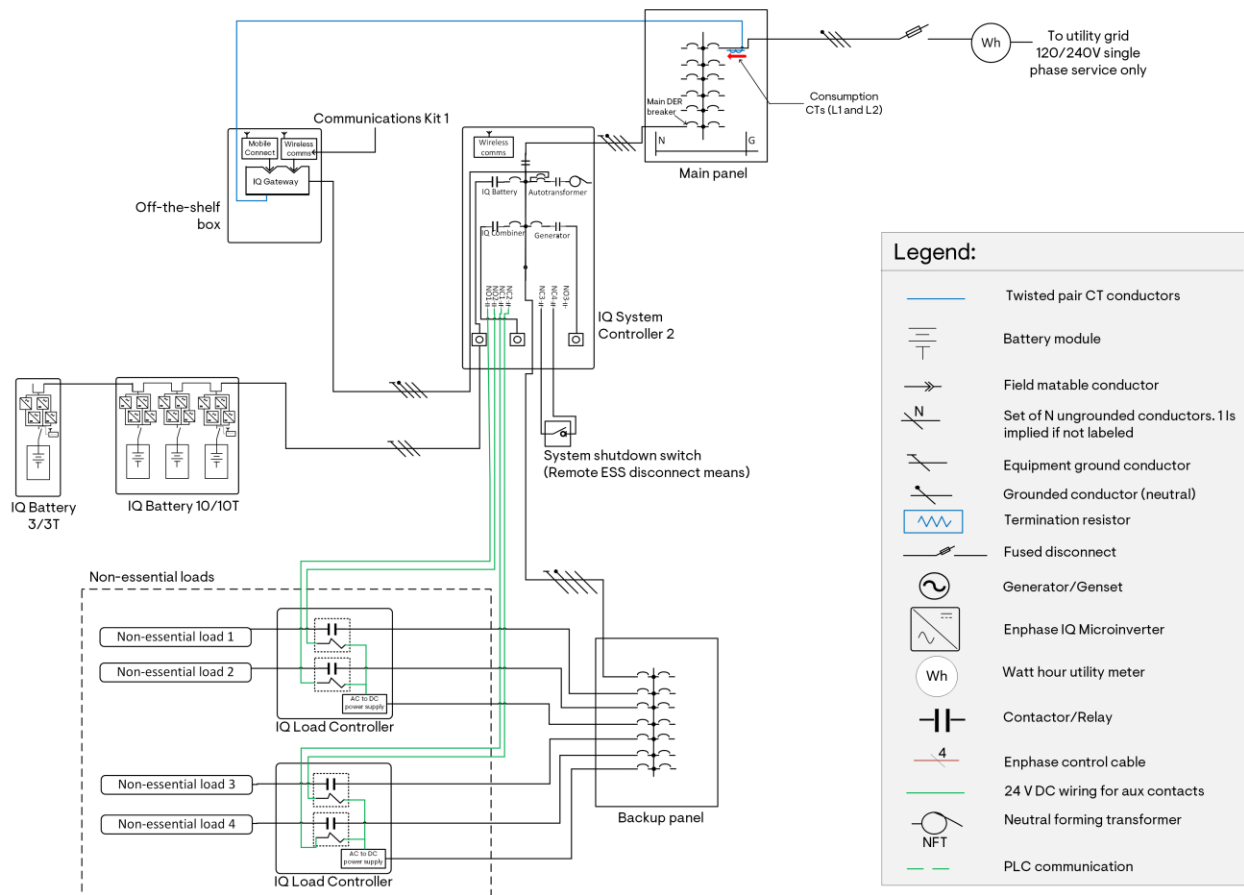

NOTES:

1. EES systems using IQ System Controller 2 and IQ Battery 3/3T/10/10T can only support battery storage of up to 40 kWh.
2. Self-Consumption battery mode is not available in Battery Only configurations. Savings and Full Backup modes are available and can be accessed using the settings in the Enphase Installer App or Enphase App. Refer to the [System profiles](#) section for details on system behavior in these modes.
3. The System Shutdown Switch can be used as a remote ESS disconnecting means where required.
4. Any system with an IQ Battery 5P must have Wi-Fi or Ethernet as the primary mode of internet connectivity and an Enphase Mobile Connect as a backup mode of internet connectivity.

With generator

With IQ Battery 5P and IQ System Controller 3G

Figure 22: Battery Only grid-forming partial home backup configuration with IQ Battery 5P and IQ System Controller 3G

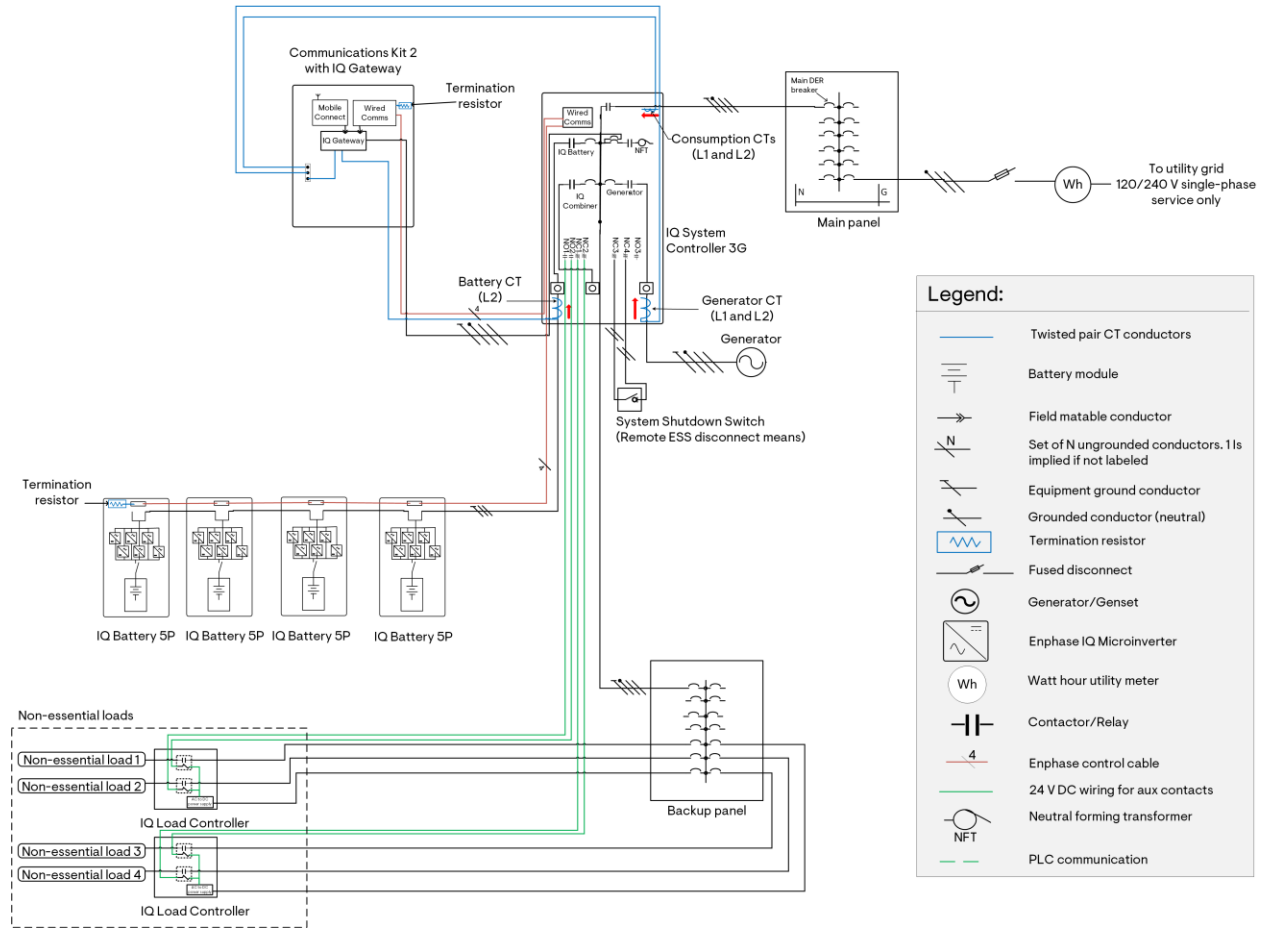

NOTES:

1. The power control system for Battery Oversubscription feature support for systems using IQ Gateway and older generation IQ Combiners are being evaluated. In the meantime, IQ Combiner 5/5C can be used instead of the IQ Gateway and Communications Kit 2 to enable Battery Oversubscription and install up to 40 kWh, i.e., eight IQ Battery 5P.
2. Self-Consumption battery mode is not available in Battery Only configurations. Savings and Full Backup modes are available and can be accessed using the settings in the Enphase Installer App or Enphase App. Refer to the [System profiles](#) section for details on system behavior in these modes.
3. IQ Gateway and a Mobile Connect cellular modem must be ordered separately from COMMS-KIT-02.
4. The System Shutdown Switch can be used as a remote ESS disconnecting means where required.
5. The generator power rating must be at least 143% of the IQ Battery array continuous power rating. Refer to the [Generator sizing](#) section for details.
6. Refer to the [Generator tech brief](#) for details on supported generator makes and additional installation requirements.

7. Any system with an IQ Battery 5P must have Wi-Fi or Ethernet as the primary mode of internet connectivity and an Enphase Mobile Connect as a backup mode of internet connectivity.
8. The diagram does not show a remote start for the generator. Refer to [Appendix B](#) for details.

With IQ Battery 3/3T/10/10T and IQ System Controller 2

Figure 23: Battery Only grid-forming partial home backup configuration with IQ Battery 3/3T/10/10T and IQ System Controller 2

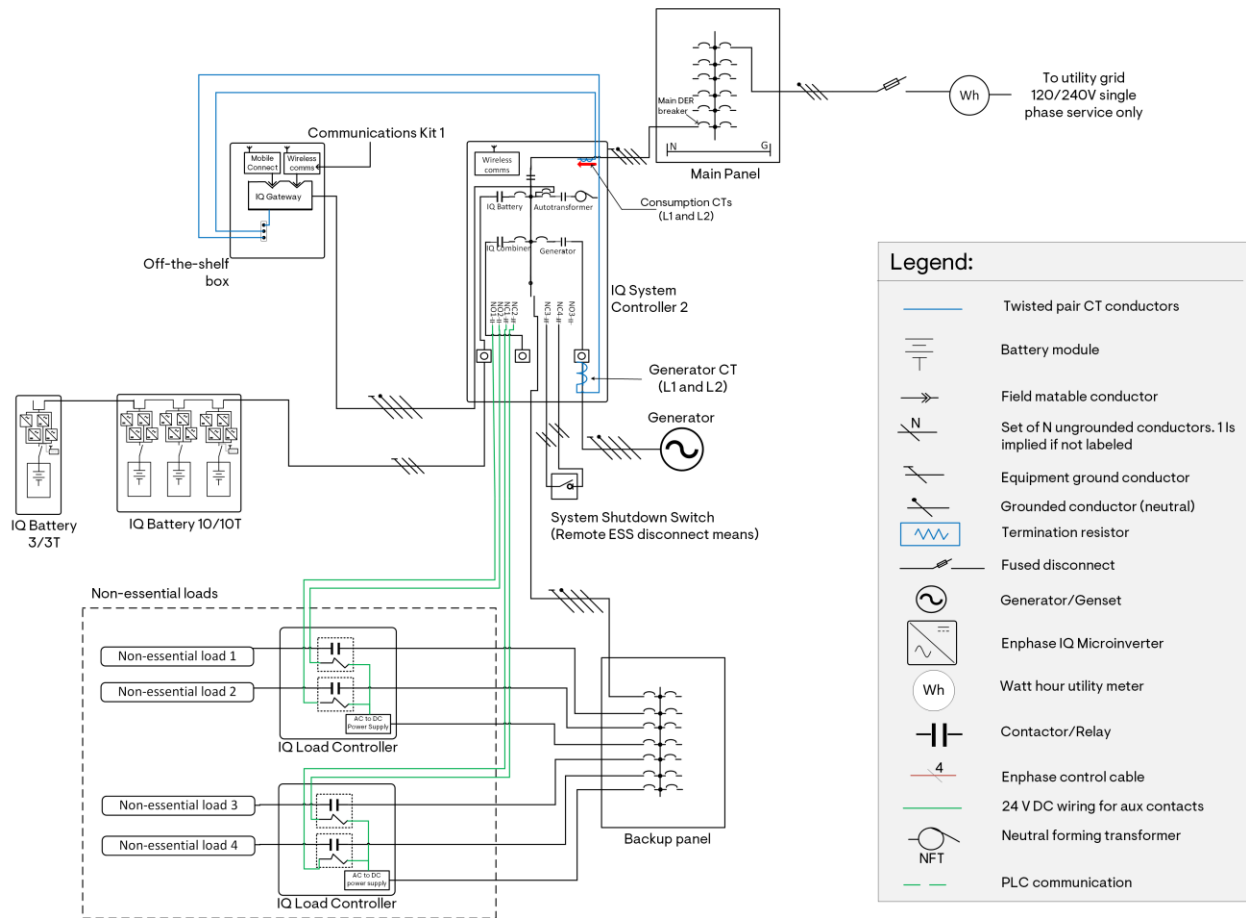

NOTES:

1. EES systems using IQ System Controller 2 and IQ Battery 3T/10T can support battery storage of up to 40 kWh.
2. Self-Consumption battery mode is not available in Battery Only configurations. Savings and Full backup modes are available and can be accessed using the settings in the Enphase Installer App or Enphase App. Refer to the [System profiles](#) section for details on system behavior in these modes.
3. The System Shutdown Switch can be used as a remote ESS disconnecting means where required.
4. The generator power rating must be at least 143% of the IQ Battery array continuous power rating. Refer to the [Generator sizing](#) section for details.
5. Refer to the [Generator tech brief](#) for details on supported generator makes and additional installation requirements.
6. Any system with an IQ Battery 5P must have Wi-Fi or Ethernet as the primary mode of internet connectivity and an Enphase Mobile Connect as a backup mode of internet connectivity.

- The diagram does not show a remote start for the generator. Refer to [Appendix B](#) for details.

Solar + Battery

Whole home backup

This configuration provides backup for all loads in a home at all times of day and night. The battery array must be appropriately sized to supply the loads. Depending on the size of the IQ Battery array, the system will be able to operate in off-grid mode for extended periods. Up to two IQ Load Controllers can be used for circuit-level load control of backed-up loads.

Without generator

With IQ Battery 5P

With IQ8 Series Microinverters, IQ Combiner 5/5C and IQ System Controller 3

Figure 24: Whole home backup configuration with IQ8 Series Microinverters and IQ Battery 5P

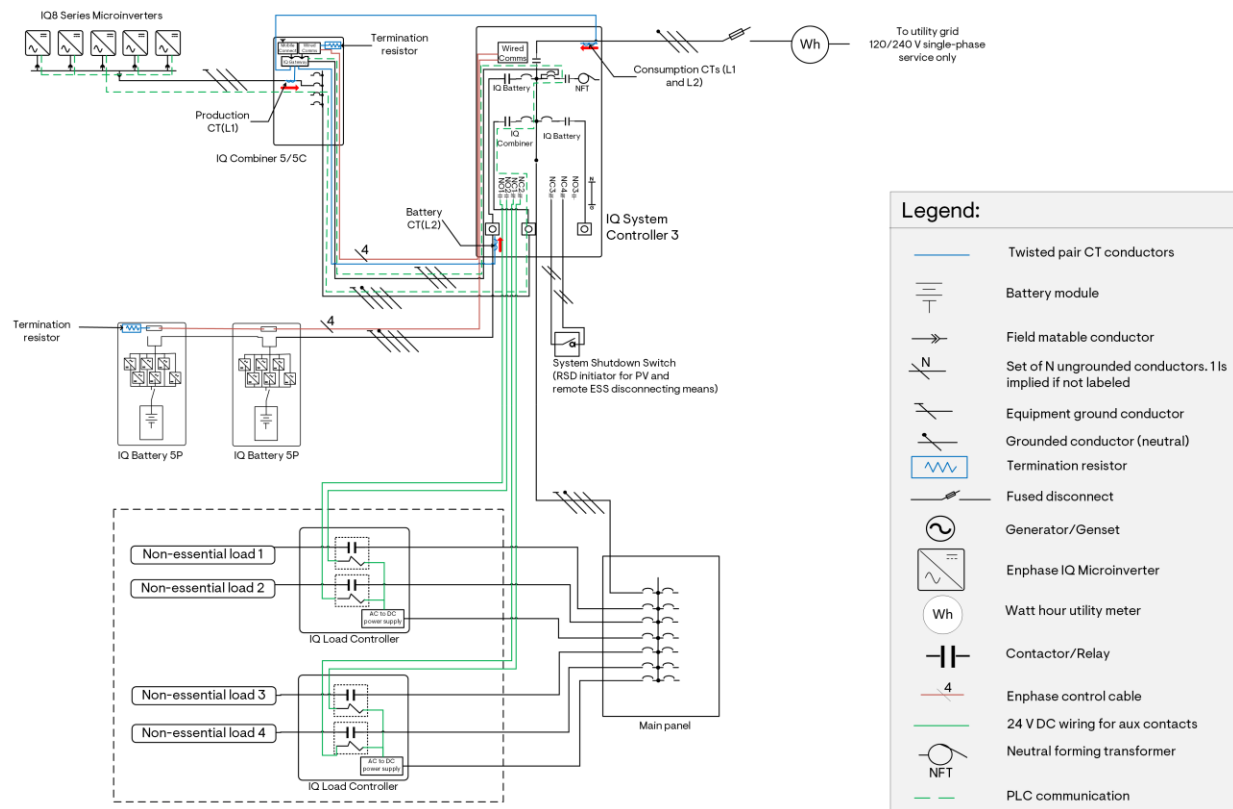

NOTES:

- IQ8 Series Microinverters cannot be mixed with other Enphase microinverters as they are incompatible with older generations of Enphase microinverters, including IQ6 and IQ7 Series Microinverters. This applies to all system configurations, with and without storage.
- The IQ System Controller 3 can support up to 80 kWh (40 kWh on each Battery port) IQ Battery 5P using the IQ Battery Oversubscription feature. Without battery oversubscription, the battery storage capacity is 40 kWh (20 kWh on each Battery port).
- Hold-down kits must be installed with breakers inside IQ Combiner 5/5C.
- IQ System Controller 3/3G has an integrated hold-down kit and is compatible with Eaton, ABB/GE, and Siemens breakers for DERs.

5. The System Shutdown Switch is the rapid shutdown initiator for PV. It can also be used as a remote ESS disconnecting means where required.
6. If more than 64 A of IQ8 Series Microinverters need to be installed, the excess PV must be split into a grid-tied system.

System configuration with more than four IQ Battery 5P units

The extra battery port on the IQ System Controller 3 can accommodate additional batteries.

Figure 25: Example of a whole home backup configuration with more than four IQ Battery 5P units

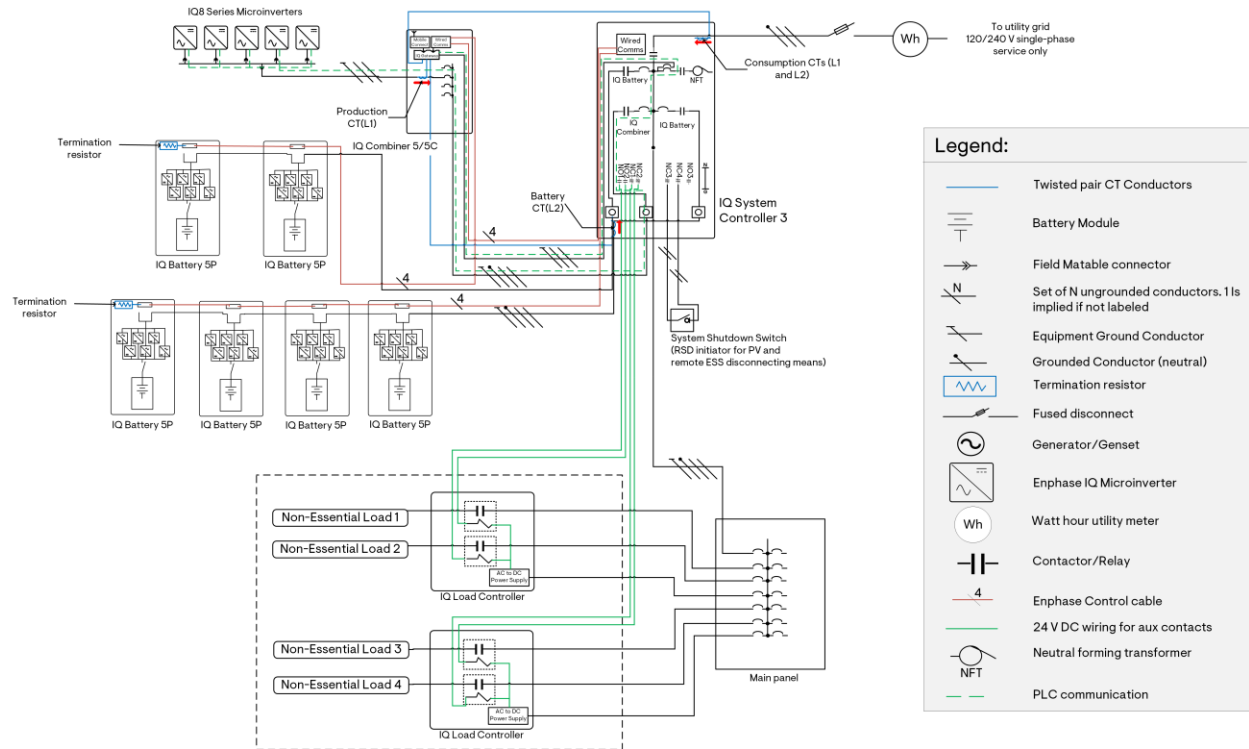

NOTES:

1. IQ8 Series Microinverters cannot be mixed with other Enphase microinverters as they are incompatible with older generations of Enphase microinverters, including IQ6 and IQ7 Series Microinverters. This applies to all system configurations, with and without storage.
2. The IQ System Controller 3 can support up to 80 kWh (40 kWh on each Battery port) IQ Battery 5P using the IQ Battery Oversubscription feature. Without battery oversubscription, the battery storage capacity is 40 kWh (20 kWh on each battery port). Each battery circuit’s continuous current rating must be less than or equal to 64 A, i.e., it must be protected by an 80 A breaker.
3. Use the Enphase Installer App to assign batteries to the respective ports.
4. It is recommended to add four batteries to one port before adding batteries to the other port.
5. If the Battery Oversubscription feature is used, add four batteries on each port before oversubscribing one port with more than four batteries.
6. Hold-down kits must be installed with breakers inside IQ Combiner 5/5C.
7. IQ System Controller 3/3G has an integrated hold-down kit and is compatible with Eaton, ABB/GE, and Siemens breakers for DERs.
8. The System Shutdown Switch is the rapid shutdown initiator for PV. It can also be used as a remote ESS disconnecting means where required.

- When using the additional battery port to install IQ Battery 5P, Termination resistors should be used to terminate the Enphase Control Cable at the end of the two IQ Battery branches.

With IQ6/7 Series Microinverters, IQ Combiner 5/5C and IQ System Controller 3

Figure 26: Whole home backup configuration using IQ6/7 Series Microinverters and IQ Battery 5P

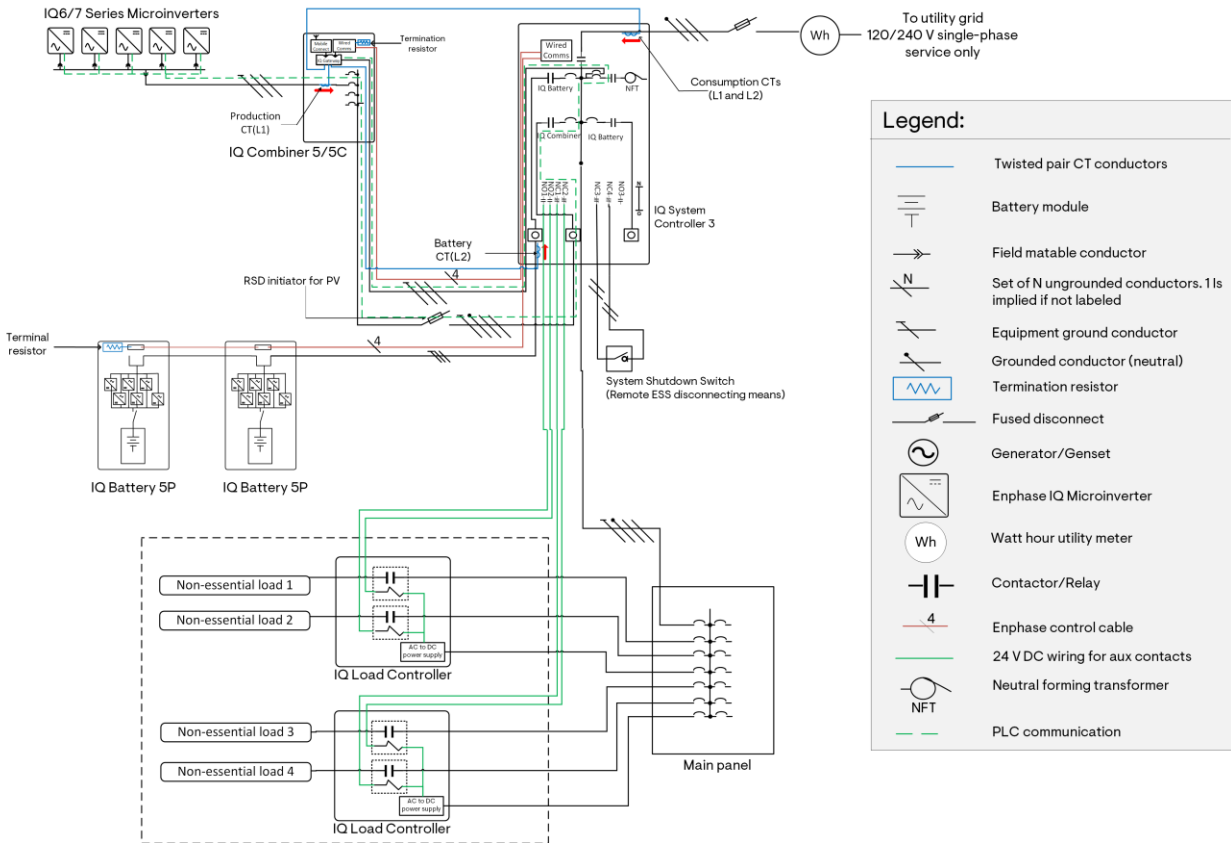

NOTES:

- IQ8 Series Microinverters cannot be mixed with other Enphase microinverters as they are incompatible with older generations of Enphase microinverters, including IQ6 and IQ7 Series Microinverters. This applies to all system configurations, with and without storage.
- The IQ System Controller 3 can support up to 80 kWh (40 kWh on each battery port) IQ Battery 5P using the IQ Battery Oversubscription feature. Without battery oversubscription, the battery storage capacity is 40 kWh (20 kWh on each battery).
- IQ System Controller 3/3G has an integrated hold-down kit and is compatible with Eaton, ABB/GE, and Siemens breakers for DERs.
- The rated continuous power output of the microinverter array must not exceed 150% of the IQ Battery array’s rated power output. If the microinverter array exceeds this ratio, PV load shedding must be implemented to shed excess PV when the system transitions to off-grid mode.
- The System Shutdown Switch is **not** the rapid shutdown initiator for PV. The PV breakers inside the IQ Combiner or PV sub-panel can be used as the rapid shutdown initiator if the NEC code adopted does not specify a single initiator. If the NEC code mandates a single initiator and if the IQ System Controller is readily accessible, the aggregate PV breaker inside the IQ System Controller can act as the rapid shutdown initiator. If it is not readily accessible, a disconnect must

be installed between the IQ System Controller and IQ Combiner 5C/PV sub-panel to function as the PV rapid shutdown disconnect.



NOTE: IQ System Controller’s door is lockable, enabling it to be locked when the breaker is off for safety.

- The System Shutdown Switch can be used as a remote ESS disconnecting means where required. For systems with more than 64 A of IQ7/IQ6 Series Microinverters, microinverters exceeding 64 A rating can be added to the main panel.

With M Series Microinverters, COMMS-KIT-02, and IQ System Controller 3

Figure 27: Whole home backup configuration using M Series Microinverters and IQ Battery 5P with IQ System Controller 3

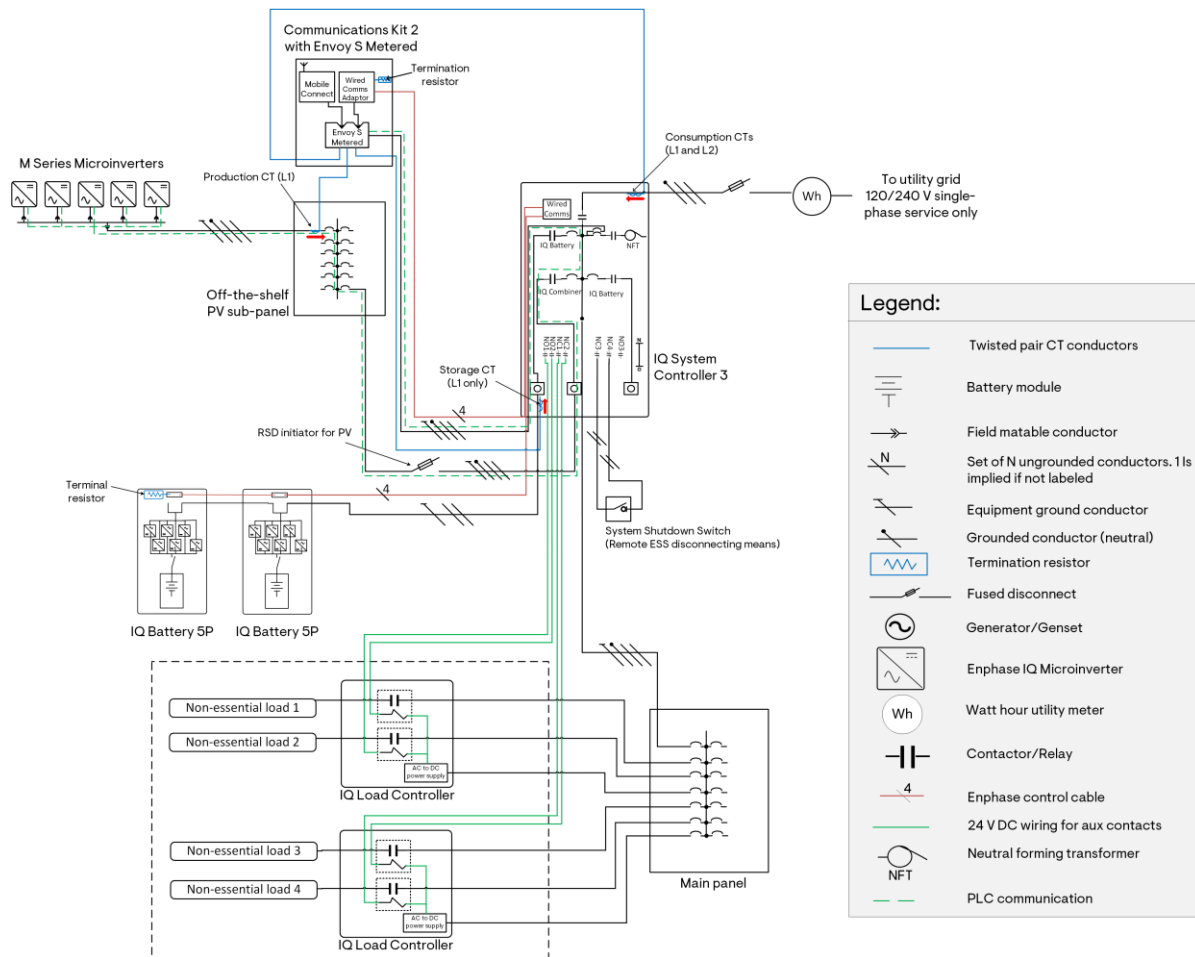

NOTES:

- M Series Microinverters are incompatible with newer IQ8 or IQ6/IQ7 Microinverters. This applies to all system configurations with and without storage.
- Use a jumper cable to short the L2 and L3 terminals in the Envoy S Metered power terminal. These are marked “B” and “C” respectively.
- COMMS-KIT-02 does not ship with Envoy S Metered and Mobile Connect cellular modem. These must be ordered separately.

4. IQ System Controller 3/3G has an integrated hold-down kit and is compatible with Eaton, ABB/GE, and Siemens breakers for DERs.
5. The rated continuous power output of the microinverter array must not exceed 150% of the IQ Battery array's rated power output. If the microinverter array exceeds this ratio, PV load shedding must be implemented to shed excess PV when the system transitions to off-grid mode.
6. The System Shutdown Switch is **not** the rapid shutdown initiator for PV. The PV breakers inside the IQ Combiner or PV sub-panel can be used as the rapid shutdown initiator if the NEC code adopted does not specify a single initiator. If the NEC code mandates a single initiator and if the IQ System Controller is readily accessible, the aggregate PV breaker inside the IQ System Controller can act as the rapid shutdown initiator. If it is not readily accessible, a disconnect must be installed between the IQ System Controller and IQ Combiner 5C/PV sub-panel to function as the PV rapid shutdown disconnect.



NOTE: IQ System Controller's door is lockable, enabling it to be locked when the breaker is off for safety.

7. The System Shutdown Switch can be used as a remote ESS disconnecting means where required.
8. Any system with an IQ Battery 5P must have Wi-Fi or Ethernet as the primary mode of internet connectivity and an Enphase Mobile Connect as a backup mode of internet connectivity.
9. For systems with more than 64 A of M Series Microinverters, microinverters exceeding 64 A rating can be added to the main panel.

With IQ Battery 3/3T/10/10T

With IQ8 Series Microinverters, IQ Combiner 4/4C and IQ System Controller 2

Figure 28: Whole home backup configuration using IQ8 Series Microinverters and IQ Battery 3/3T/10/10T

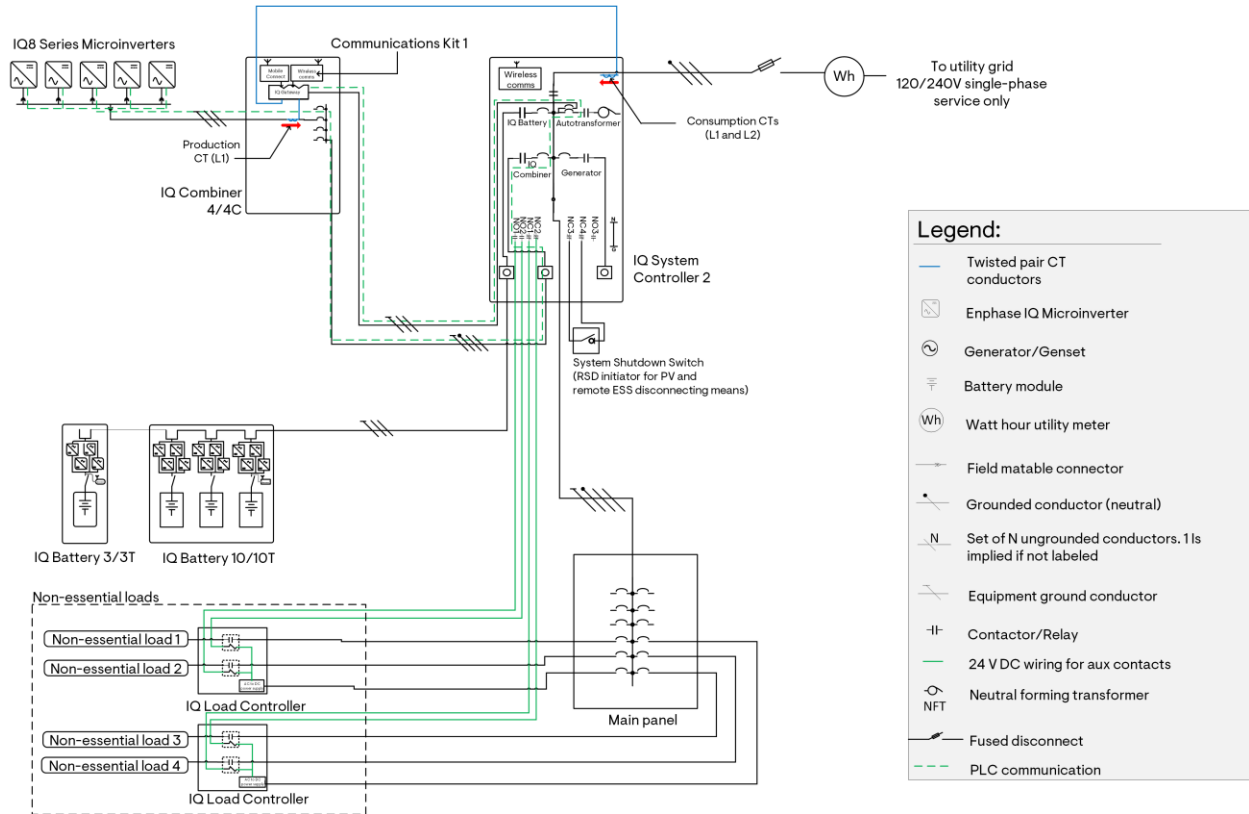

NOTES:

1. The IQ System Controller 2 can support up to 40 kWh IQ Battery 3T/10T.
2. Hold-down kits must be installed with breakers inside IQ Combiner 4/4C.
3. Hold-down kits must be used in IQ System Controller 2.
4. The System Shutdown Switch is the rapid shutdown initiator for PV. It can also be used as a remote ESS disconnecting means where required.
5. If more than 48 IQ8 series microinverters are installed in a system with a single IQ Battery 3T, implement PV shedding to remove additional PV when the system transitions to the microgrid,
6. or add additional batteries.
7. If more than 64 A of IQ8 Series Microinverters need to be installed, the excess PV must be split into a grid-tied system.

With IQ6/7 Series Microinverters, IQ Combiner 4/4C and IQ System Controller 2

Figure 29: Whole home backup configuration using IQ6/7 Series Microinverters and IQ Battery 3/3T/10/10T

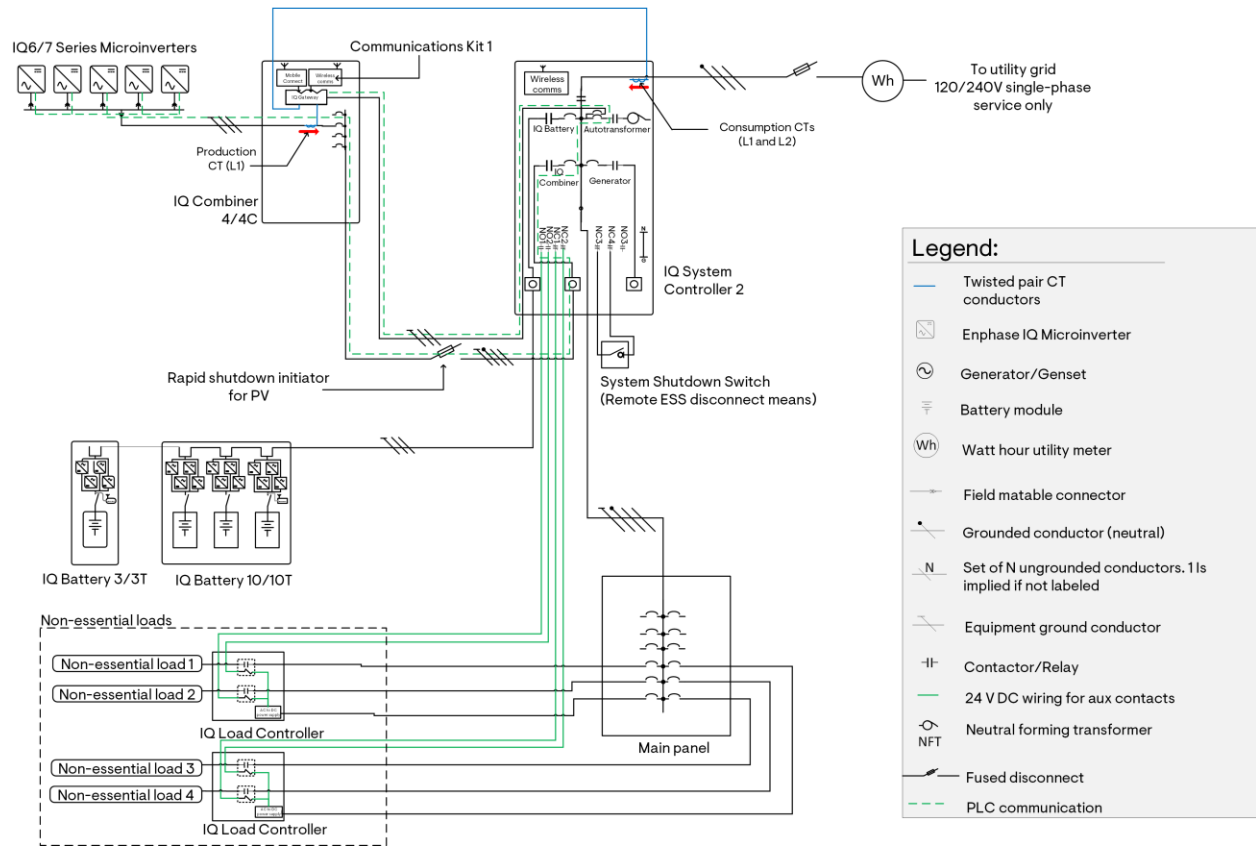

NOTES:

1. Hold-down kits must be used in IQ System Controller 2.
2. EES systems using IQ System Controller 2 and IQ Battery 3T/10T can support battery storage of up to 40 kWh.
3. The System Shutdown Switch can be used as a remote ESS disconnecting means where required.
4. The System Shutdown Switch is not the rapid shutdown initiator for PV. The PV breakers inside the IQ Combiner or PV sub-panel can be used as the rapid shutdown initiator if the NEC code adopted does not specify a single initiator. If the NEC code mandates a single initiator and if the IQ System Controller is readily accessible, the aggregate PV breaker inside the IQ System Controller can act as the rapid Shutdown Initiator. If it is not readily accessible, a disconnect must be installed between the IQ System Controller and IQ Combiner 5C/PV sub-panel to function as the PV rapid shutdown disconnect.



NOTE: IQ System Controller’s door is lockable, enabling it to be locked when the breaker is off for safety.

5. The rated continuous power output of the microinverter array must not exceed 150% of the IQ Battery array's rated power output. If the microinverter array exceeds this ratio, PV load shedding must be implemented to shed excess PV when the system transitions to off-grid mode.
6. For systems with more than 64 A of IQ7/6 Series Microinverters, microinverters exceeding 64 A rating can be added to the main panel.

With M Series Microinverters, COMMS-KIT-01, and IQ System Controller 2

Figure 30: Whole home backup configuration using M Series Microinverters and IQ Battery 3/3T/10/10T

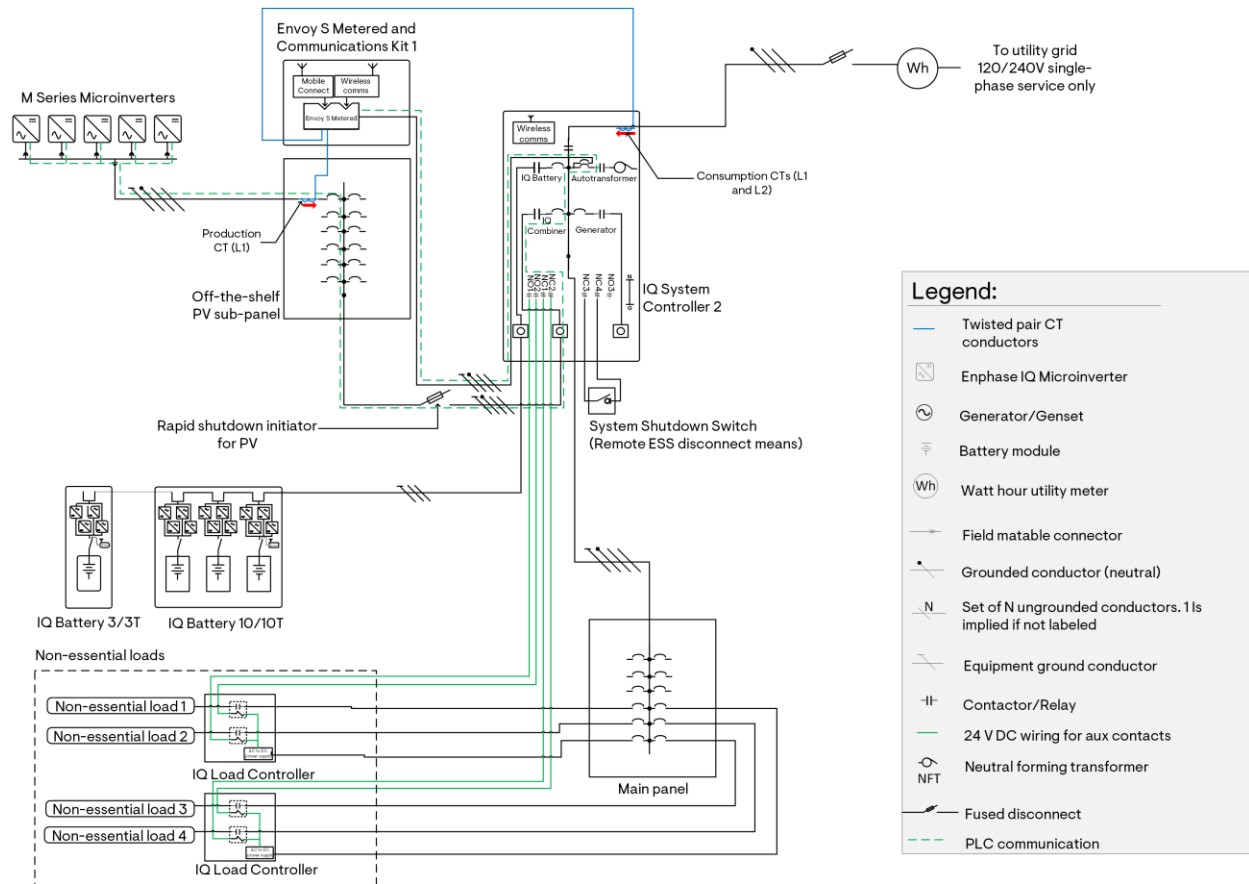

NOTES:

1. M Series Microinverters are incompatible with newer IQ8 or IQ6/IQ7 Microinverters. This applies to all system configurations with and without storage.
2. EES systems using IQ System Controller 2 and IQ Battery 3T/10T can support battery storage of up to 40 kWh.
3. Off-the-shelf combiner is used to house the IQ Gateway, COMMS-KIT-01, and Mobile Connect.
4. The System Shutdown Switch can be used as a remote ESS disconnecting means where required.
5. The System Shutdown Switch is not the rapid shutdown initiator for PV. The PV breakers inside the IQ Combiner or PV sub-panel can be used as the rapid shutdown initiator if the NEC code adopted does not specify a single initiator. If the NEC code mandates a single initiator and if the IQ System Controller is readily accessible, the aggregate PV breaker inside the IQ System Controller can act as the rapid shutdown initiator. If it is not readily accessible, a disconnect must be installed between the IQ System Controller and IQ Combiner 5C/PV sub-panel to function as the PV rapid shutdown disconnect.



NOTE: IQ System Controller’s door is lockable, enabling it to be locked when the breaker is off for safety. IQ Battery 3/3T/10/10T requires the use of hold-down kits on IQ System Controller 2

- The rated continuous power output of the microinverter array must not exceed 150% of the IQ Battery array’s rated power output. If the microinverter array exceeds this ratio, PV load shedding must be implemented to shed excess PV when the system transitions to off-grid mode.
- For systems with more than 64 A of M Series Microinverters, microinverters exceeding 64 A rating can be added to the main panel.

With generator

With IQ Battery 5P

With IQ8 Series Microinverters, IQ Combiner 5/5C and IQ System Controller 3G

Figure 31: Whole home backup configuration with IQ8 Series Microinverters and IQ Battery 5P

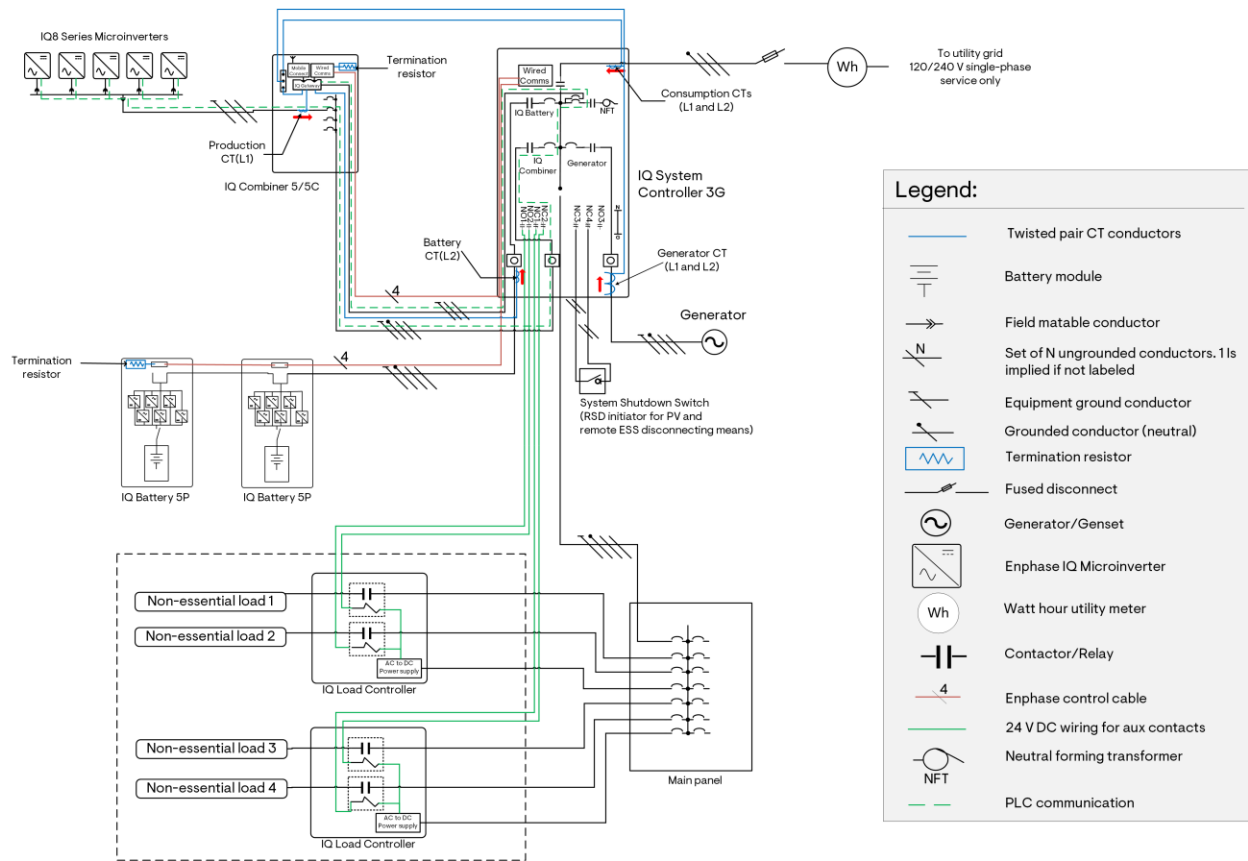

NOTES:

- The IQ System Controller 3G can support up to 40 kWh IQ Battery 5P using the IQ Battery Oversubscription feature. Without battery oversubscription, the battery storage capacity is 20 kWh.
- Hold-down kits must be installed with breakers inside IQ Combiner 5/5C.
- IQ System Controller 3/3G has an integrated hold-down kit and is compatible with Eaton, ABB/GE, and Siemens breakers for DERs.

4. The generator power rating must be at least 143% of the IQ Battery array continuous power rating or 100% of the microinverter array continuous power rating, whichever is higher. Refer to the [Generator sizing](#) section for details.
5. Refer to the [Generator integration technical brief](#) for generator integration, operating modes, system commissioning, etc.
6. To monitor the consumption from the generator, the system will require an additional pair of generator CTs linked in parallel with the Consumption CTs. These CTs (2x CT-200-CLAMP or 2x CT-200-SPLIT) must be purchased separately.
7. The System Shutdown Switch is the rapid shutdown initiator for PV. It can also be used as a remote ESS disconnecting means where required.
8. If more than 64 A of IQ8 Series Microinverters need to be installed, the excess PV must be split into a grid-tied system.
9. The diagram does not show a remote start for the generator. Refer to [Appendix B](#) for details.

With IQ6/7 Series Microinverters, IQ Combiner 5/5C and IQ System Controller 3G

Figure 32: Whole home backup configuration with IQ6/7 Series Microinverters and IQ Battery 5P

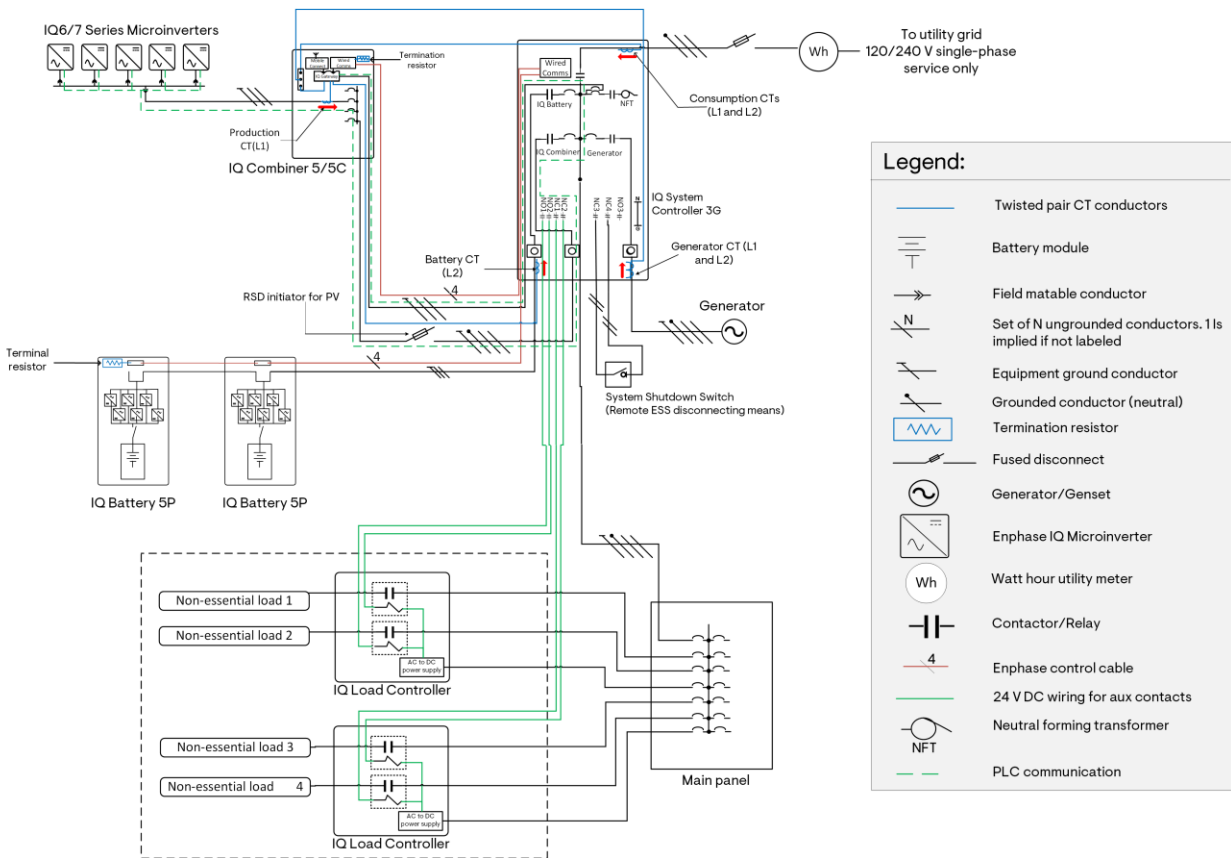

NOTES:

1. The IQ System Controller 3G can support up to 40 kWh IQ Battery 5P using the IQ Battery Oversubscription feature. Without battery oversubscription, the battery storage capacity is 20 kWh.
2. Hold-down kits need not be installed with breakers inside IQ Combiner 5/5C.

3. IQ System Controller 3/3G has an integrated hold-down kit and is compatible with Eaton, ABB/GE, and Siemens breakers for DERs.
4. The rated continuous power output of the microinverter array must not exceed 150% of the IQ Battery array's rated power output. If the microinverter array exceeds this ratio, PV load shedding must be implemented to shed excess PV when the system transitions to off-grid mode.
5. The generator power rating must be at least 143% of the IQ Battery array continuous power rating. Refer to the [Generator sizing](#) section for details.
6. Refer to the [Generator integration technical brief](#) for generator integration, operating modes, system commissioning, etc.
7. To monitor the consumption from the generator, systems with a generator will require an additional pair of generator CTs linked in parallel with the Consumption CTs. These CTs (2x CT-200-CLAMP or 2x CT-200-SPLIT) must be purchased separately.
8. The System Shutdown Switch is not the rapid shutdown initiator for PV. The PV breakers inside the IQ Combiner or PV sub-panel can be used as the rapid shutdown initiator if the NEC code adopted does not specify a single initiator. If the NEC code mandates a single initiator and if the IQ System Controller is readily accessible, the aggregate PV breaker inside the IQ System Controller can act as the rapid shutdown initiator. If it is not readily accessible, a disconnect must be installed between the IQ System Controller and IQ Combiner 5C/PV sub-panel to function as the PV rapid shutdown disconnect.



NOTE: IQ System Controller's door is lockable, enabling it to be locked when the breaker is off for safety.

9. The System Shutdown Switch can be used as a remote ESS disconnecting means where required.
10. The diagram does not show a remote start for the generator. Refer to [Appendix B](#) for details.

With M Series Microinverters, COMMS-KIT-02, and IQ System Controller 3G

Figure 33: Whole home backup configuration with M Series Microinverters and IQ Battery 5P

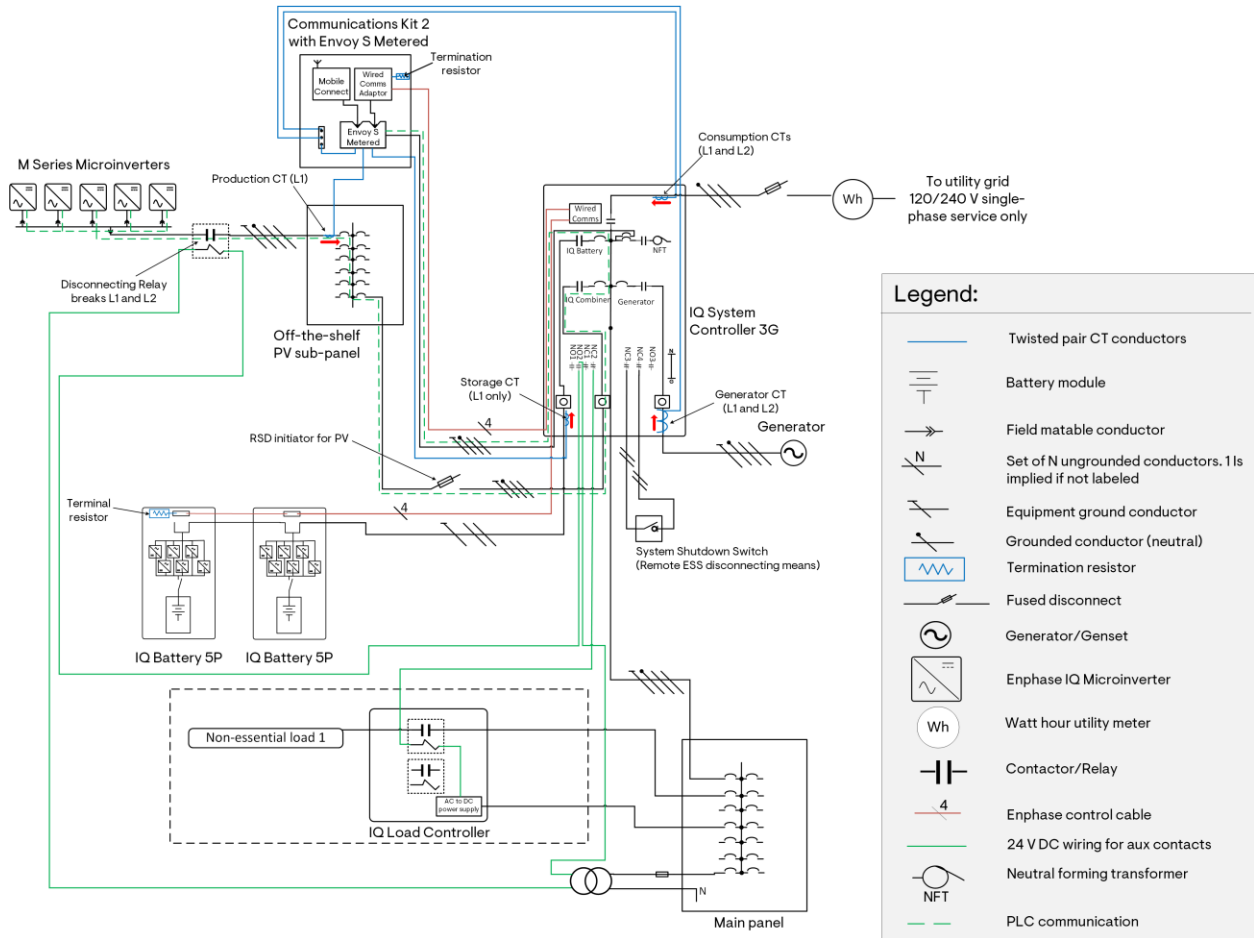

NOTES:

1. Use a jumper cable to shorten the L2 and L3 terminals in the Envoy S Metered power terminal. These are marked “B” and “C” respectively.
2. The IQ System Controller 3G can support up to 40 kWh IQ Battery 5P using the IQ Battery Oversubscription feature. Without battery oversubscription, the battery storage capacity is 20 kWh.
3. Hold-down kits need not be installed with breakers inside IQ Combiner 5/5C.
4. IQ System Controller 3/3G has an integrated hold-down kit and is compatible with Eaton, ABB/GE, and Siemens breakers for DERs.
5. The rated continuous power output of the microinverter array must not exceed 150% of the IQ Battery array’s rated power output.
6. The generator power rating must be at least 143% of the IQ Battery array continuous power rating. Refer to the [Generator sizing](#) section for details.
7. PV shedding must be implemented to shed the microinverter array when the generator is connected to the microgrid and producing power. Refer to the [Generator integration technical brief](#) for details on PV shedding implementation.

8. Refer to the [Generator integration technical brief](#) for generator integration, operating modes, system commissioning, and other details.
9. To monitor the consumption from the generator, systems with a generator will require an additional pair of generator CTs linked in parallel with the Consumption CTs. These CTs (2x CT-200-CLAMP or 2x CT-200-SPLIT) must be purchased separately.
10. The System Shutdown Switch is not the rapid shutdown initiator for PV. The PV breakers inside the IQ Combiner or PV sub-panel can be used as the rapid shutdown initiator if the NEC code adopted does not specify a single initiator. If the NEC code mandates a single initiator and if the IQ System Controller is readily accessible, the aggregate PV breaker inside the IQ System Controller can act as the rapid shutdown initiator. If it is not readily accessible, a disconnect must be installed between the IQ System Controller and IQ Combiner 5C/PV sub-panel to function as the PV rapid shutdown disconnect.



NOTE: IQ System Controller’s door is lockable, enabling it to be locked when the breaker is off for safety.

11. The System Shutdown Switch can be used as a remote ESS disconnecting means where required.
12. The diagram does not show a remote start for the generator. Refer to [Appendix B](#) for details.

With IQ Battery 3/3T/10/10T

With IQ8 series Microinverters, IQ Combiner 4/4C and IQ System Controller 2

Figure 34: Whole home backup configuration with IQ8 Series Microinverters and IQ Battery 3/3T/10/10T

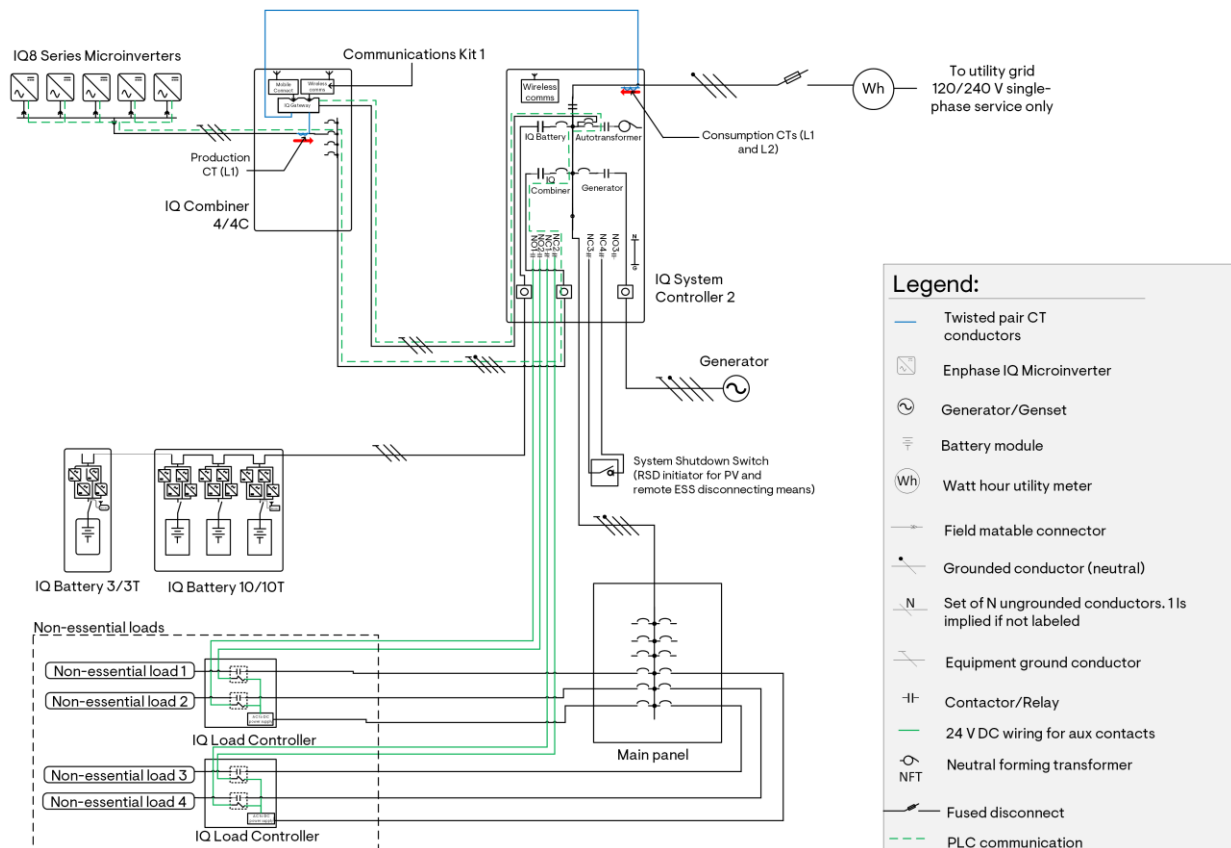

NOTES:

1. The IQ System Controller 2 can support up to 40 kWh IQ Battery 3T/10T.
2. Hold-down kits must be installed with breakers inside IQ Combiner 4/4C.
3. The generator power rating must be at least 143% of the IQ Battery array continuous power rating or 100% of the microinverter array continuous power rating, whichever is higher. Refer to the [Generator sizing](#) section for details.
4. Refer to the [Generator integration technical brief](#) for generator integration, operating modes, system commissioning, etc.
5. The System Shutdown Switch is the rapid shutdown initiator for PV. The System Shutdown Switch can be used as a remote ESS disconnecting means where required.
6. If more than 48 IQ8 Series Microinverters are installed in a system with a single IQ Battery 3T, implement PV shedding to remove additional PV when the system transitions to off-grid or add additional batteries.
7. If more than 64 A of IQ8 Series Microinverters need to be installed, the excess PV must be split into a grid-tied system.
8. The shown diagram does not show a remote start for the generator. Refer to [Appendix B](#) for details.

With IQ6/7 Series Microinverters, IQ Combiner 4/4C and IQ System Controller 2

Figure 35: Whole home backup configuration with IQ6/7 Series Microinverters and IQ Battery 3/3T/10/10T

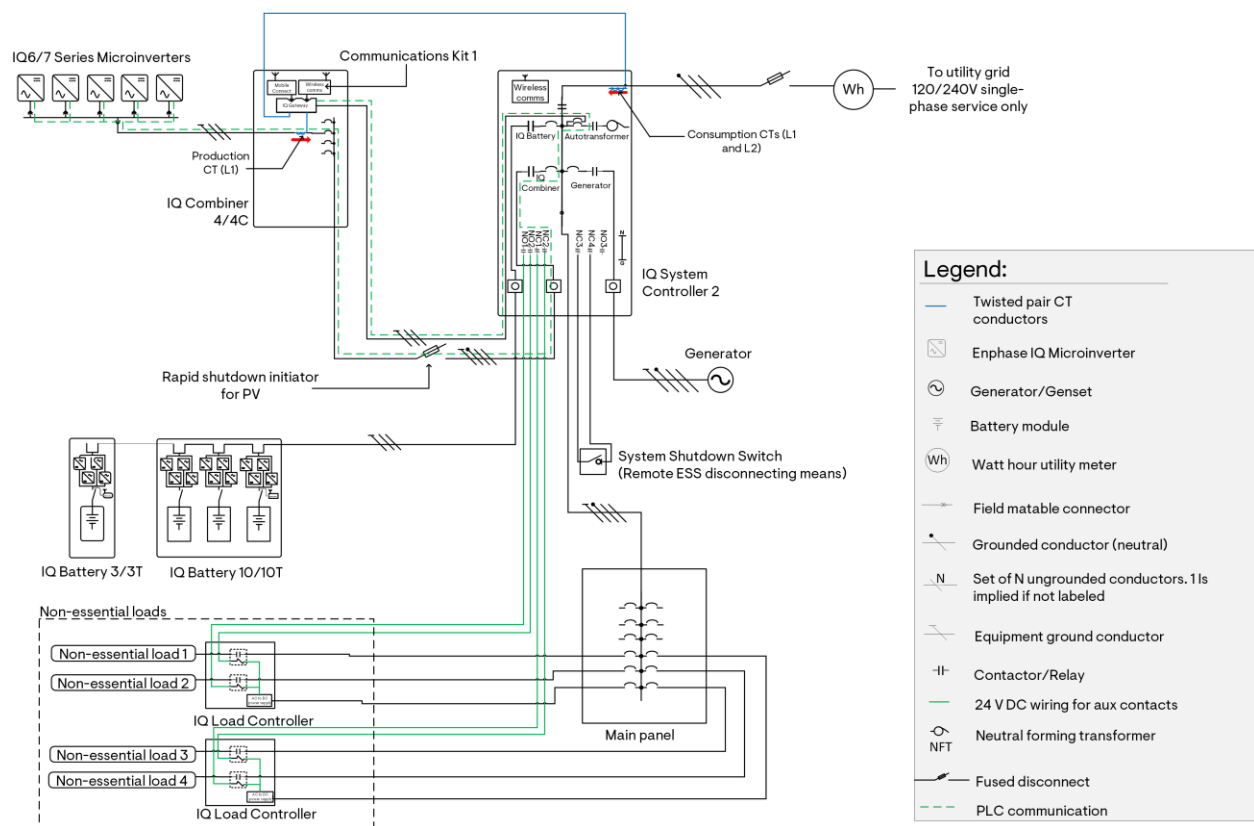

NOTES:

1. EES systems using IQ System Controller 2 and IQ Battery 3T/10T can support battery storage of up to 40 kWh.

2. The rated continuous power output of the microinverter array must not exceed 150% of the IQ Battery array’s rated power output. If the microinverter array exceeds this ratio, PV load shedding must be implemented to shed excess PV when the system transitions to off-grid mode.
3. The generator power rating must be at least 143% of the IQ Battery array continuous power rating. Refer to the [Generator sizing](#) section for details.
4. Refer to the [Generator integration technical brief](#) for generator integration, operating modes, system commissioning, etc.
5. The System Shutdown Switch can be used as a remote ESS disconnecting means where required.
6. The System Shutdown Switch is not the rapid shutdown initiator for PV. The PV breakers inside the IQ Combiner or PV sub-panel can be used as the rapid shutdown initiator if the NEC code adopted does not specify a single initiator. If the NEC code mandates a single initiator and if the IQ System Controller is readily accessible, the aggregate PV breaker inside the IQ System Controller can act as the rapid shutdown initiator. If it is not readily accessible, a disconnect must be installed between the IQ System Controller and IQ Combiner 5C/PV sub-panel to function as the PV rapid shutdown disconnect.



NOTE: IQ System Controller’s door is lockable, enabling it to be locked when the breaker is off for safety.

7. IQ Battery 3/3T/10/10T requires the use of hold-down kits on IQ System Controller 2
8. The diagram does not show a remote start for the generator. Refer to [Appendix B](#) for details.

With M Series Microinverters, COMMS-KIT-01, and IQ System Controller 2

Figure 36: Whole home backup configuration with M Series Microinverters and IQ Battery 3/3T/10/10T

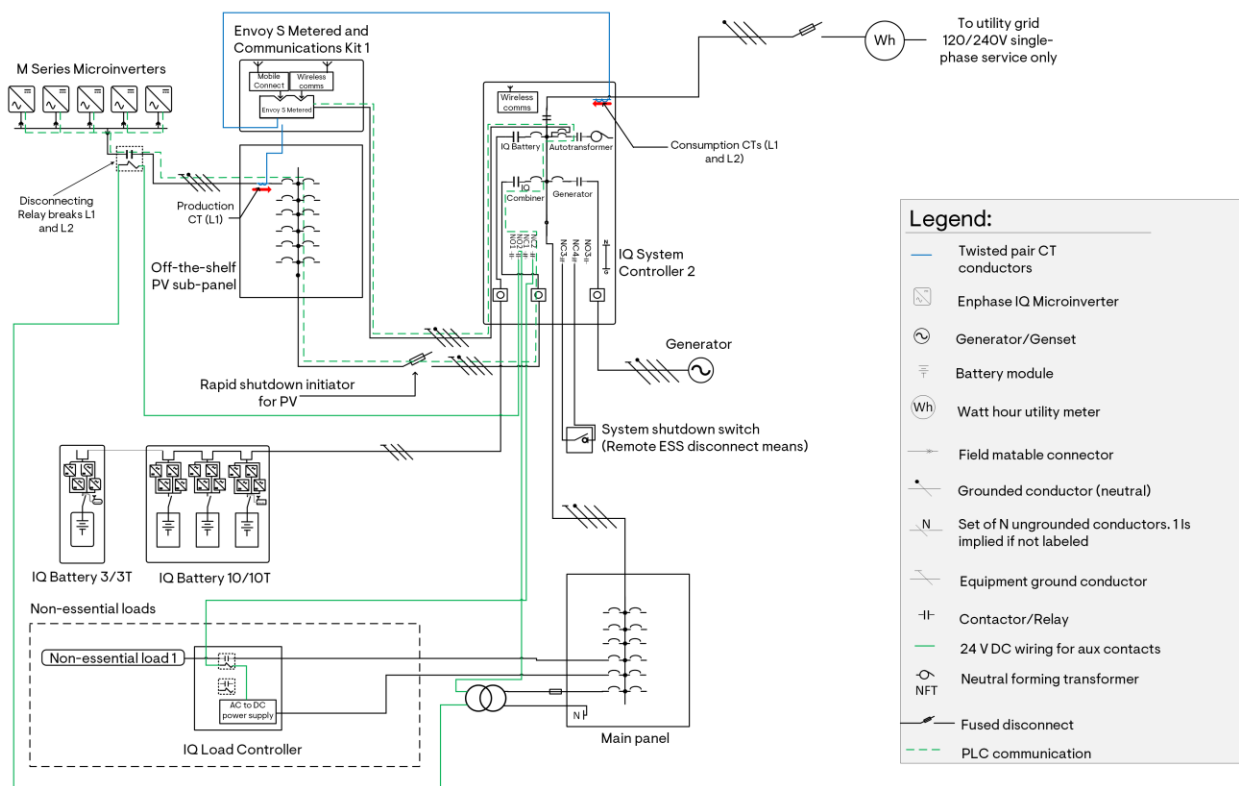

NOTES:

1. EES systems using IQ System Controller 2 and IQ Battery 3T/10T can support battery storage of up to 40 kWh.
2. The rated continuous power output of the microinverter array must not exceed 150% of the IQ Battery array's rated power output.
3. PV shedding must be implemented to shed the microinverter array when the generator is connected to the microgrid and producing power. Refer to the [Generator integration technical brief](#) for details on PV shedding implementation.
4. The System Shutdown Switch can be used as a remote ESS disconnecting means where required.
5. The System Shutdown Switch is not the rapid shutdown initiator for PV. The PV breakers inside the IQ Combiner or PV sub-panel can be used as the rapid shutdown initiator if the NEC code adopted does not specify a single initiator. If the NEC code mandates a single initiator and if the IQ System Controller is readily accessible, the aggregate PV breaker inside the IQ System Controller can act as the rapid shutdown initiator. If it is not readily accessible, a disconnect must be installed between the IQ System Controller and IQ Combiner 5C/PV sub-panel to function as the PV rapid shutdown disconnect.
NOTE: IQ System Controller's door is lockable, enabling it to be locked when the breaker is off for safety. IQ Battery 3/3T/10/10T requires the use of hold-down kits on IQ System Controller 2.
6. The diagram does not show a remote start for the generator. Refer to [Appendix B](#) for details.

Partial home backup

In this configuration, essential loads are aggregated on a backup load panel. All the loads connected to the backup load panel will transition to off-grid seamlessly. It is strongly advised to use up to two IQ Load Controllers to eliminate heavy power demand when the system enters a backup mode.

Without generator

With IQ Battery 5P

With IQ8 Series Microinverters, IQ Combiner 5/5C and IQ System Controller 3

Figure 37: Partial home backup configuration with IQ8 Series Microinverters and IQ Battery 5P

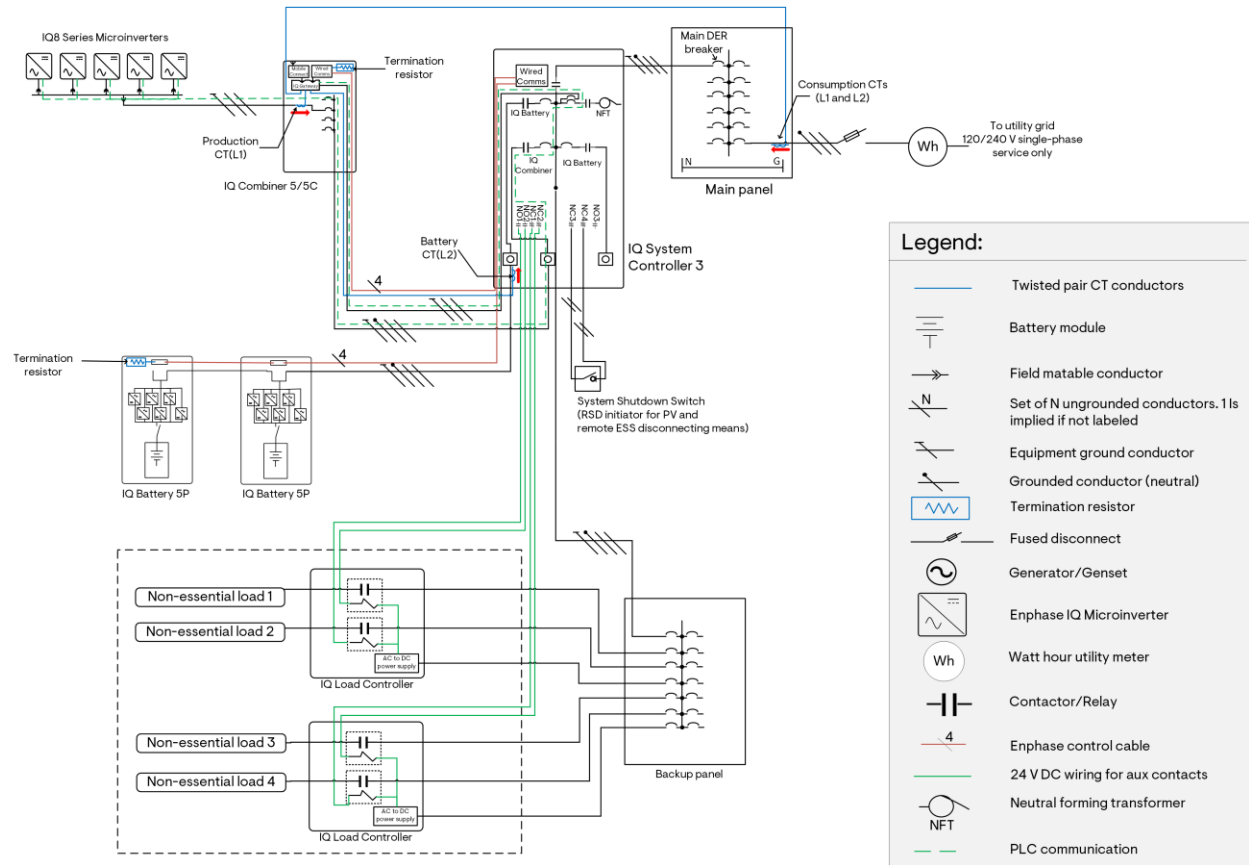

NOTES:

1. IQ8 Series Microinverters cannot be mixed with other Enphase microinverters as they are incompatible with older generations of Enphase microinverters, including IQ6 and IQ7 Series Microinverters. This applies to all system configurations, with and without storage.
2. The IQ System Controller 3 can support up to 80 kWh (40 kWh on each Battery port) IQ Battery 5P using the IQ Battery Oversubscription feature. Without battery oversubscription, the battery storage capacity is 40 kWh (20 kWh on each battery port).
3. Hold-down kits must be installed with breakers inside IQ Combiner 5/5C.
4. IQ System Controller 3/3G has an integrated hold-down kit and is compatible with Eaton, ABB/GE, and Siemens breakers for DERs.
5. The System Shutdown Switch is the rapid shutdown initiator for PV. It can also be used as a remote ESS disconnecting means where required.
6. If more than 64 A of IQ8 Series Microinverters need to be installed, the excess PV must be split into a grid-tied system.

System configuration with more than four IQ Battery 5P units

The extra battery port on the IQ System Controller 3 may accommodate additional batteries. The batteries can only be added to the extra battery port if four IQ Battery 5P units are plugged into it, as illustrated in the figure.

Figure 38: Example of a partial home backup configuration with more than four IQ Battery 5P units

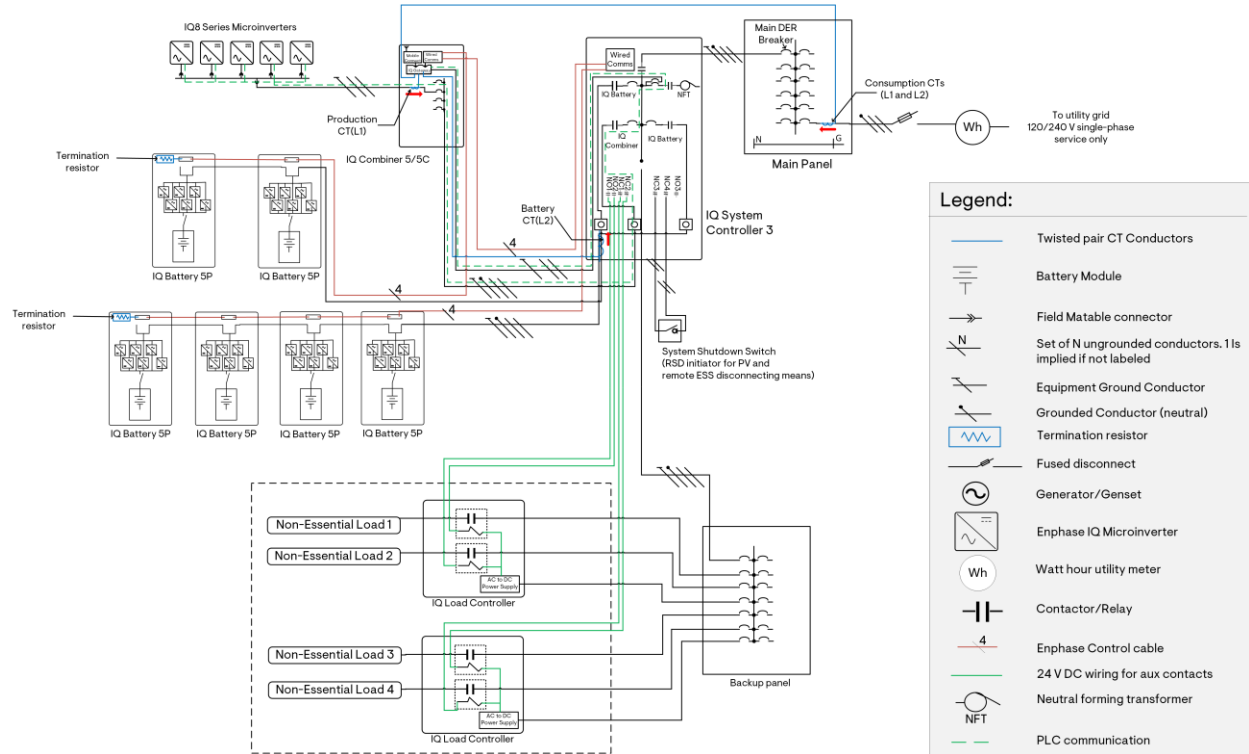

NOTES:

1. IQ8 Series Microinverters cannot be mixed with other Enphase microinverters as they are incompatible with older generations of Enphase microinverters, including IQ6 and IQ7 Series Microinverters. This applies to all system configurations, with and without storage.
2. The IQ System Controller 3 can support up to 80 kWh (40 kWh on each Battery port) IQ Battery 5P using the IQ Battery Oversubscription feature. Without battery oversubscription, the battery storage capacity is 40 kWh (20 kWh on each battery port). Each battery circuit’s continuous current rating must be less than or equal to 64 A, i.e., it must be protected by an 80 A breaker.
3. Use the Enphase Installer App to assign batteries to the respective ports.
4. It is recommended to add four batteries to one port before adding batteries to the other port.
5. If the Battery Oversubscription feature is used, add four batteries on each port before oversubscribing one port with more than four batteries.
6. Hold-down kits must be installed with breakers inside IQ Combiner 5/5C.
7. IQ System Controller 3/3G has an integrated hold-down kit and is compatible with Eaton, ABB/GE, and Siemens breakers for DERs.
8. The System Shutdown Switch is the rapid shutdown initiator for PV. It can also be used as a remote ESS disconnecting means where required.

- When using the additional battery port to install IQ Battery 5P, Termination resistors should be used to terminate the Enphase Control Cable at the end of the two IQ Battery branches.

With IQ6/7 Series Microinverters, IQ Combiner 5/5C and IQ System Controller 3

Figure 39: Partial home backup configuration with IQ6/7 Series Microinverter and IQ Battery 5P

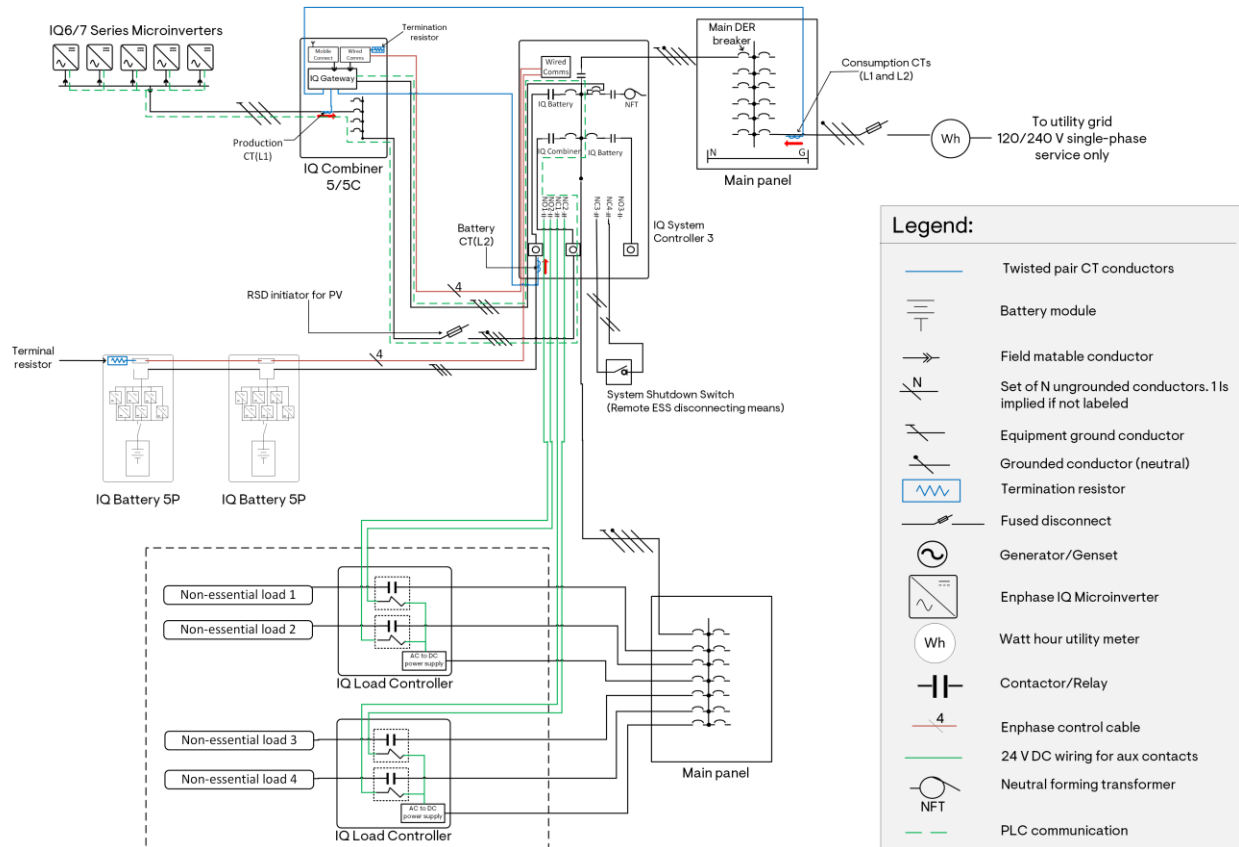

NOTES:

- IQ8 Series Microinverters cannot be mixed with other Enphase microinverters as they are incompatible with older generations of Enphase microinverters, including IQ6 and IQ7 Series Microinverters. This applies to all system configurations, with and without storage.
- The IQ System Controller 3 can support up to 80 kWh (40 kWh on each Battery port) IQ Battery 5P using the IQ Battery Oversubscription feature. Without battery oversubscription, the battery storage capacity is 40 kWh (20 kWh on each battery).
- IQ System Controller 3/3G has an integrated hold-down kit and is compatible with Eaton, ABB/GE, and Siemens breakers for DERs.
- The rated continuous power output of the microinverter array must not exceed 150% of the IQ Battery array’s rated power output. If the microinverter array exceeds this ratio, PV load shedding must be implemented to shed excess PV when the system transitions to off-grid mode.
- The System Shutdown Switch is **not** the rapid shutdown initiator for PV. The PV breakers inside the IQ Combiner or PV sub-panel can be used as the rapid shutdown initiator if the NEC code adopted does not specify a single initiator. If the NEC code mandates a single initiator and if the IQ System Controller is readily accessible, the aggregate PV breaker inside the IQ System Controller can act as the rapid shutdown initiator. If it is not readily accessible, a disconnect must

be installed between the IQ System Controller and IQ Combiner 5C/PV sub-panel to function as the PV rapid shutdown disconnect.



NOTE: IQ System Controller’s door is lockable, enabling it to be locked when the breaker is off for safety.

- The System Shutdown Switch can be used as a remote ESS disconnecting means where required.

With M Series Microinverters, COMMS-KIT-02, and IQ System Controller 3

Figure 40: Partial home backup configuration with M Series Microinverters and IQ Battery 5P

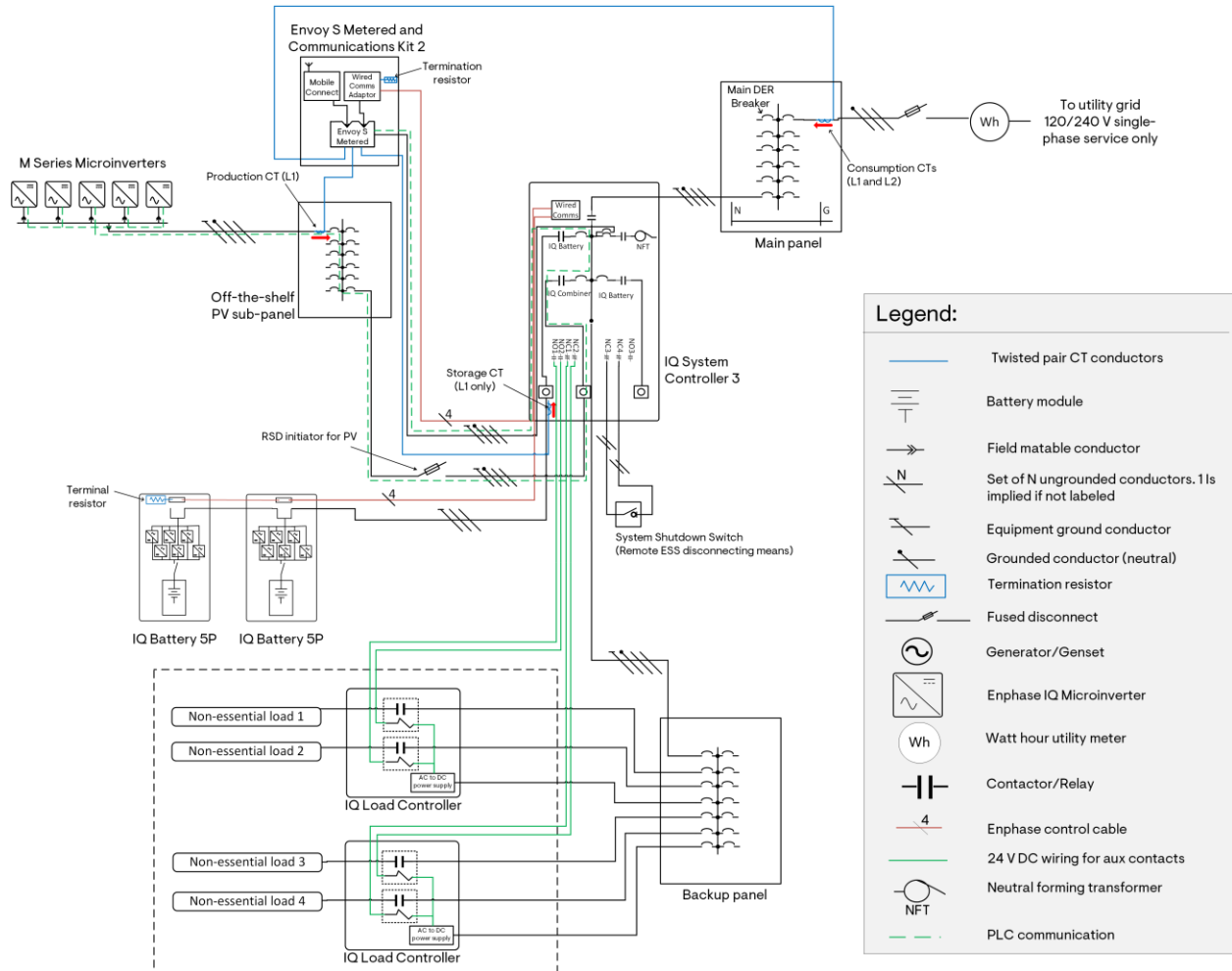

NOTES:

- M Series Microinverters are incompatible with newer IQ8 or IQ6/IQ7 Microinverters. This applies to all system configurations with and without storage.
- Use a jumper cable to shorten the L2 and L3 terminals in the Envoy S Metered power terminal. These are marked “B” and “C” respectively.
- COMMS-KIT-02 does not ship with Envoy S metered and Mobile Connect cellular modem. These must be ordered separately.
- IQ System Controller 3/3G has an integrated hold-down kit and is compatible with Eaton, ABB/GE, and Siemens breakers for DERs.

5. The rated continuous power output of the microinverter array must not exceed 150% of the IQ Battery array's rated power output. If the microinverter array exceeds this ratio, PV load shedding must be implemented to shed excess PV when the system transitions to off-grid mode.
6. The System Shutdown Switch is **not** the rapid shutdown initiator for PV. The PV breakers inside the IQ Combiner or PV sub-panel can be used as the rapid shutdown initiator if the NEC code adopted does not specify a single initiator. If the NEC code mandates a single initiator and if the IQ System Controller is readily accessible, the aggregate PV breaker inside the IQ System Controller can act as the rapid shutdown initiator. If it is not readily accessible, a disconnect must be installed between the IQ System Controller and IQ Combiner 5C/PV sub-panel to function as the PV rapid shutdown disconnect.



NOTE: IQ System Controller's door is lockable, enabling it to be locked when the breaker is off for safety.

7. The System Shutdown Switch can be used as a remote ESS disconnecting means where required.
8. Any system with an IQ Battery 5P must have Wi-Fi or Ethernet as the primary mode of internet connectivity and an Enphase Mobile Connect as a backup mode of internet connectivity.
9. For systems with more than 64 A of M series Microinverters, microinverters exceeding 64 A rating can be added to the main panel.

With IQ Battery 3/3T/10/10T

With IQ8 Series Microinverters, IQ Combiner 4/4C and IQ System Controller 2

Figure 41: Partial home backup configuration using IQ8 Series Microinverters and IQ Battery 3/3T/10/10T

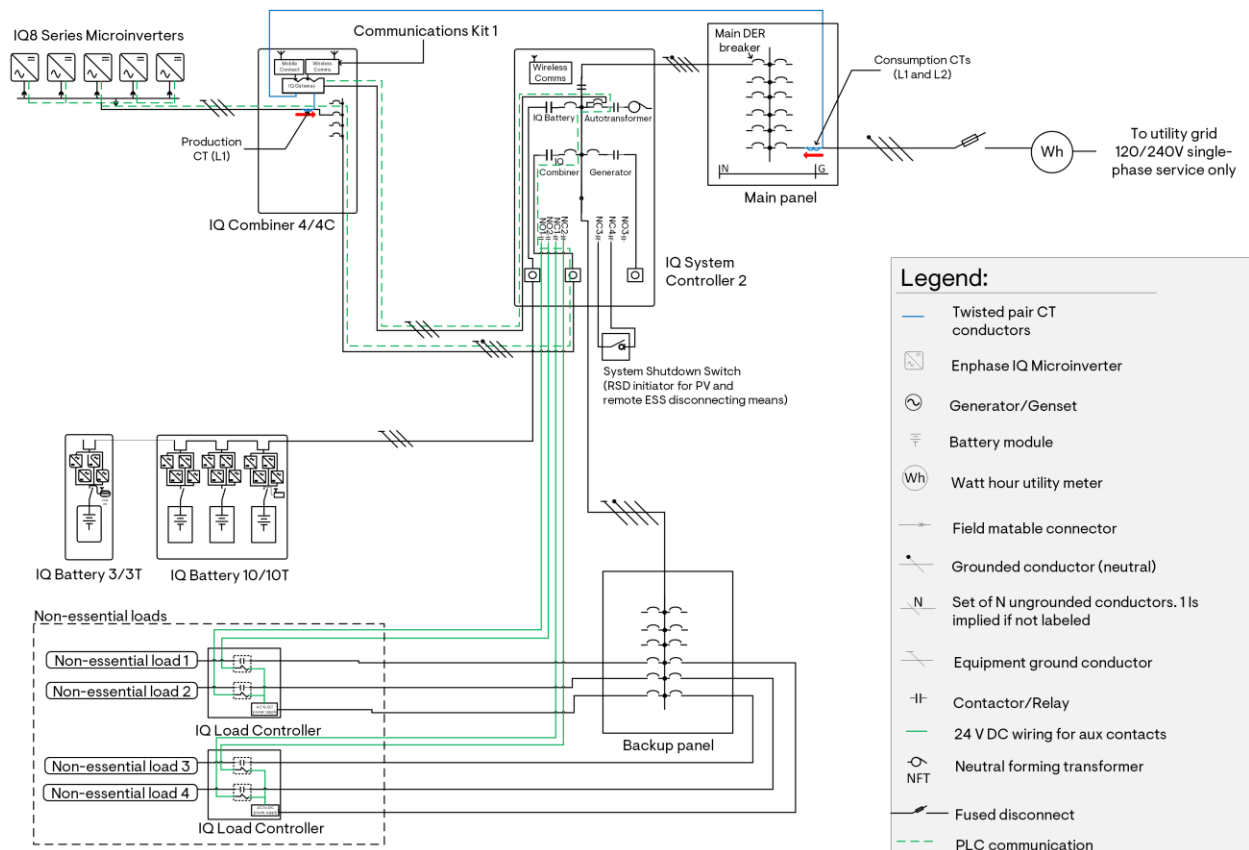

NOTES:

1. The IQ System Controller 2 can support up to 40 kWh IQ Battery 3T/10T.
2. Hold-down kits must be installed with breakers inside IQ Combiner 4/4C.
3. The System Shutdown Switch is the rapid shutdown initiator for PV. The System Shutdown Switch can be used as a remote ESS disconnecting means where required.
4. If more than 48 IQ8 Series Microinverters are installed in a system with a single IQ Battery 3T, implement PV shedding to remove additional PV when the system transitions to microgrid or add additional batteries.
5. If more than 64 A of IQ8 Series Microinverters need to be installed, the excess PV must be split into a grid-tied system. For line diagrams, refer to the Appendix.

With IQ6/7 Series Microinverters, IQ Combiner 4/4C and IQ System Controller 2

Figure 42: Partial home backup configuration using IQ6/7 Series Microinverters and IQ Battery 3/3T/10/10T

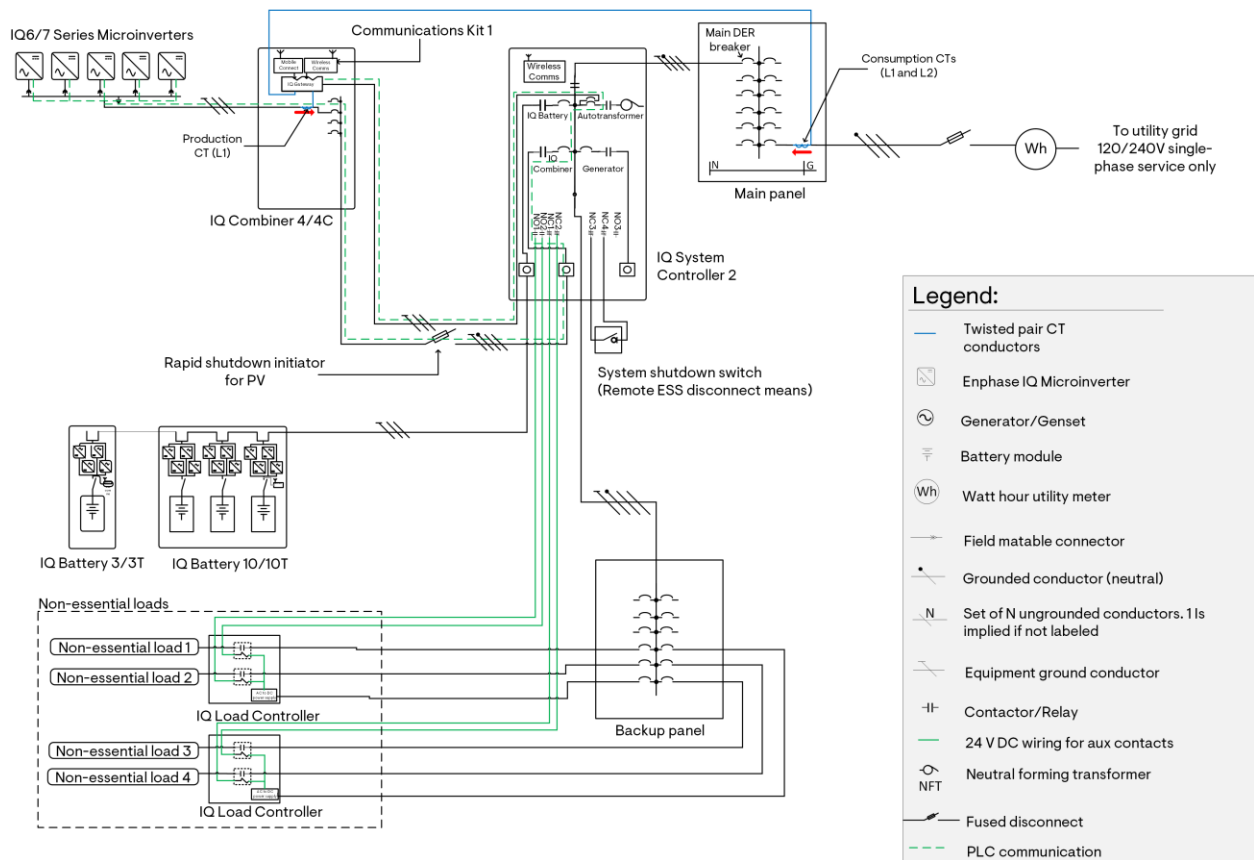

NOTES:

1. EES systems using IQ System Controller 2 and IQ Battery 3T/10T can only support battery storage of up to 40 kWh.
2. The System Shutdown Switch can be used as a remote ESS disconnecting means where required.
3. The System Shutdown Switch is not the rapid shutdown initiator for PV. The PV breakers inside the IQ Combiner or PV sub-panel can be used as the rapid shutdown initiator if the NEC code adopted does not specify a single initiator. If the NEC code mandates a single initiator and if the IQ System Controller is readily accessible, the aggregate PV breaker inside the IQ System Controller can act as the rapid shutdown initiator. If it is not readily accessible, a disconnect must

be installed between the IQ System Controller and IQ Combiner 5C/PV sub-panel to function as the PV rapid shutdown disconnect.



NOTE: IQ System Controller’s door is lockable, enabling it to be locked when the breaker is off for safety.

4. Hold-down kits must be used in IQ System Controller 2.
5. The rated continuous power output of the microinverter array must not exceed 150% of the IQ Battery array’s rated power output. If the microinverter array exceeds this ratio, PV load shedding must be implemented to shed excess PV when the system transitions to off-grid mode.
6. For a line diagram of systems with more than 64 A of PV, refer to Appendix.

With M Series Microinverters, COMMS-KIT-01, and IQ System Controller 2

Figure 43: Partial home backup configuration using M Series Microinverters and IQ Battery 3/3T/10/10T

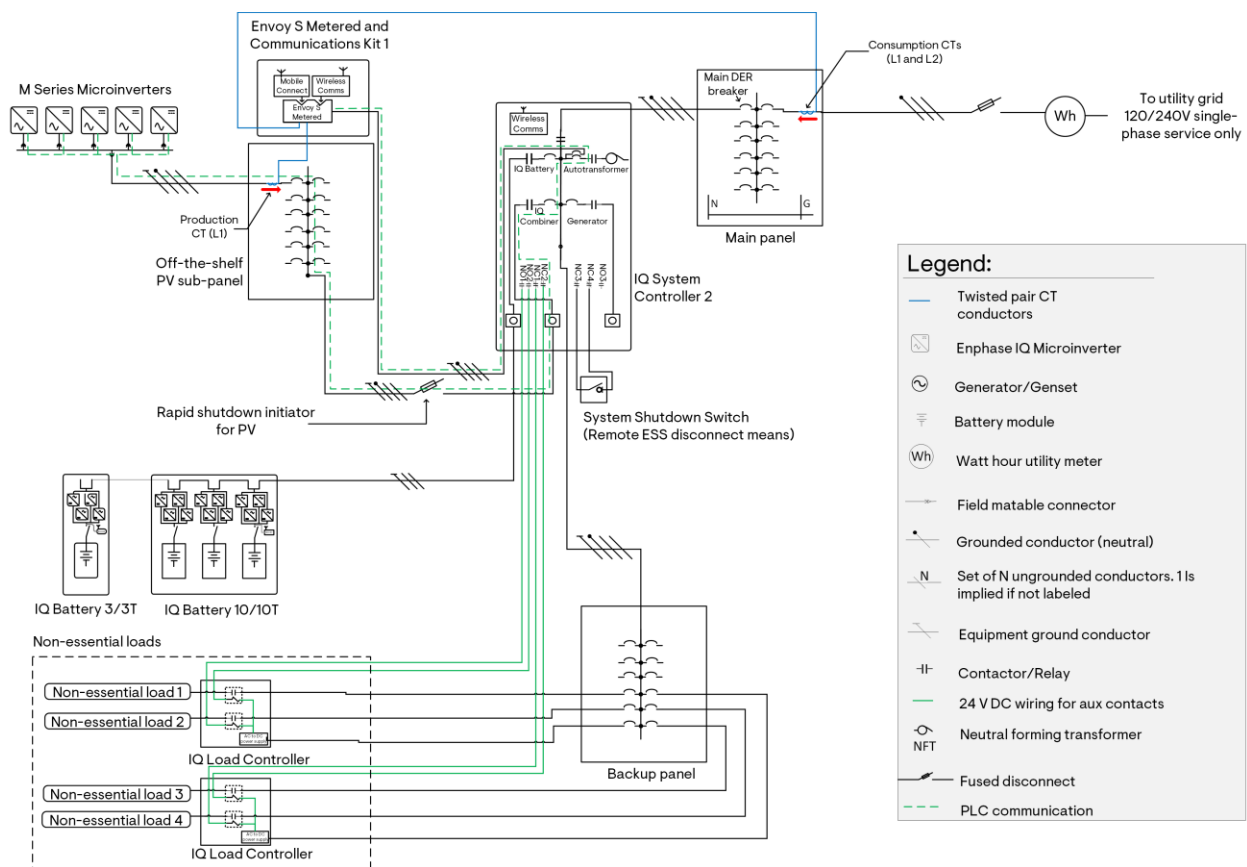

NOTES:

1. EES systems using IQ System Controller 2 and IQ Battery 3T/10T can support battery storage of up to 40 kWh.
2. The rated continuous power output of the microinverter array must not exceed 150% of the IQ Battery array’s rated power output. If the microinverter array exceeds this ratio, PV load shedding must be implemented to shed excess PV when the system transitions to off-grid mode.
3. PV shedding must be implemented to shed the microinverter array when the generator is connected to the microgrid and producing power. Refer to the [Generator integration technical brief](#) for details on PV shedding implementation.

4. The System Shutdown Switch can be used as a remote ESS disconnecting means where required.
5. The System Shutdown Switch is not the rapid shutdown initiator for PV. The PV breakers inside the IQ Combiner or PV sub-panel can be used as the rapid shutdown initiator if the NEC code adopted does not specify a single initiator. If the NEC code mandates a single initiator and if the IQ System Controller is readily accessible, the aggregate PV breaker inside the IQ System Controller can act as the rapid shutdown initiator. If it is not readily accessible, a disconnect must be installed between the IQ System Controller and IQ Combiner 5C/PV sub-panel to function as the PV rapid shutdown disconnect.
 NOTE: IQ System Controller’s door is lockable, enabling it to be locked when the breaker is off for safety. IQ Battery 3/3T/10/10T requires the use of hold-down kits on IQ System Controller 2.
6. The diagram does not show a remote start for the generator. Refer to [Appendix B](#) for details.

With generator

With IQ Battery 5P

With IQ8 Series Microinverters, IQ Combiner 5/5C and IQ System Controller 3

Figure 44: Partial home backup configuration with IQ8 Series Microinverters and IQ Battery 5P

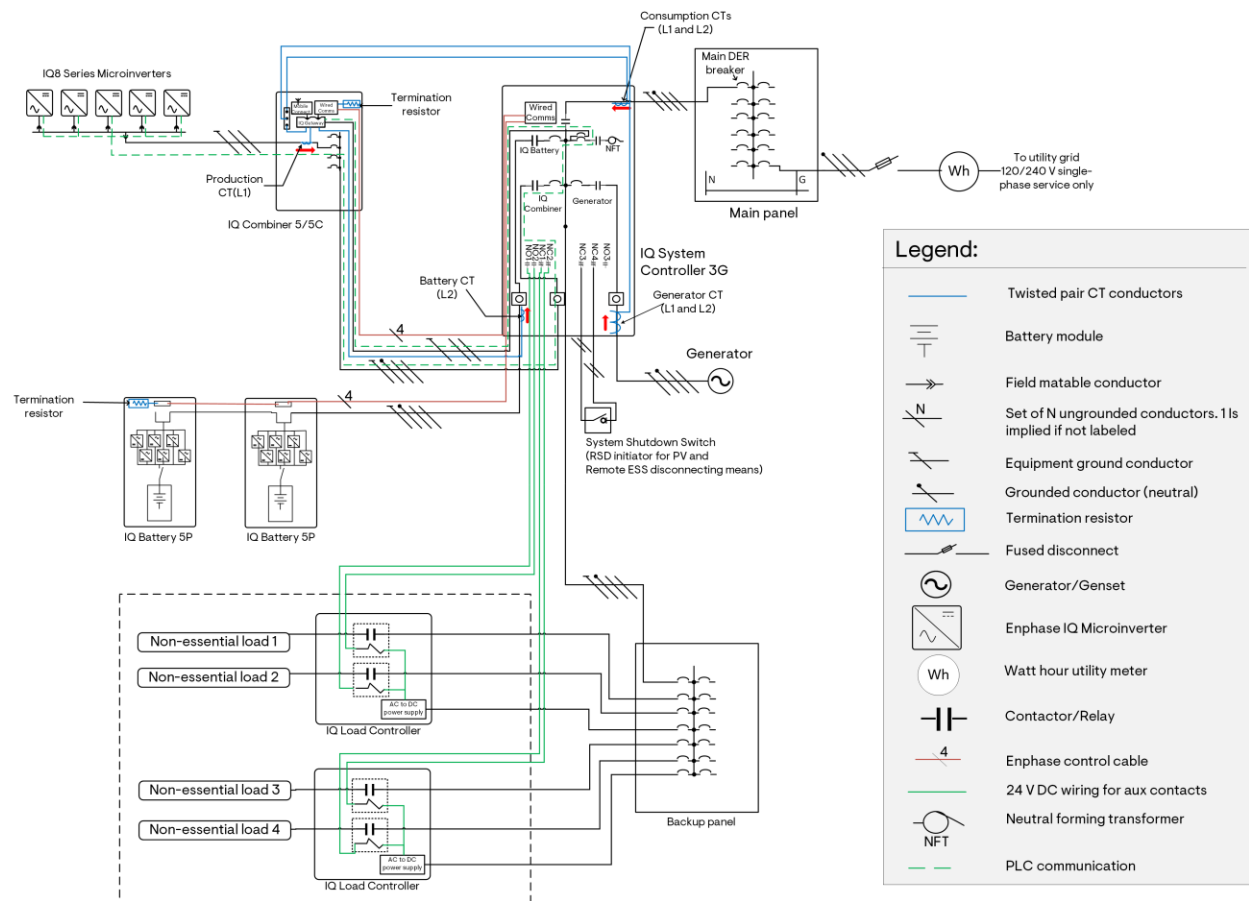

NOTES:

1. The IQ System Controller 3G can support up to 40 kWh IQ Battery 5P using the IQ Battery Oversubscription feature. Without battery oversubscription, the battery storage capacity is 20 kWh.
2. Hold-down kits must be installed with breakers inside IQ Combiner 5/5C.

3. IQ System Controller 3/3G has an integrated hold-down kit and is compatible with Eaton, ABB/GE, and Siemens breakers for DERs.
4. The generator power rating must be at least 143% of the IQ Battery array continuous power rating or 100% of the microinverter array continuous power rating, whichever is higher. Refer to the [Generator sizing](#) section for details.
5. Refer to the [Generator integration technical brief](#) for generator integration, operating modes, system commissioning, etc.
6. To monitor the consumption from the generator, systems with a generator will require an additional pair of generator CTs linked in parallel with the Consumption CTs. These CTs (2x CT-200-CLAMP or 2x CT-200-SPLIT) must be purchased separately.
7. The System Shutdown Switch is the rapid shutdown initiator for PV. The System Shutdown Switch can be used as a remote ESS disconnecting means where required.
8. If more than 64 A of IQ8 Series Microinverters need to be installed, the excess PV must be split into a grid-tied system. For a line diagram of such a system, refer to the appendix.
9. The diagram does not show a remote start for the generator. Refer to [Appendix B](#) for details.

With IQ6/7 Series Microinverters, IQ Combiner 5/5C and IQ System Controller 3

Figure 45: Partial home backup configuration with IQ7 Series Microinverters and IQ Battery 5P

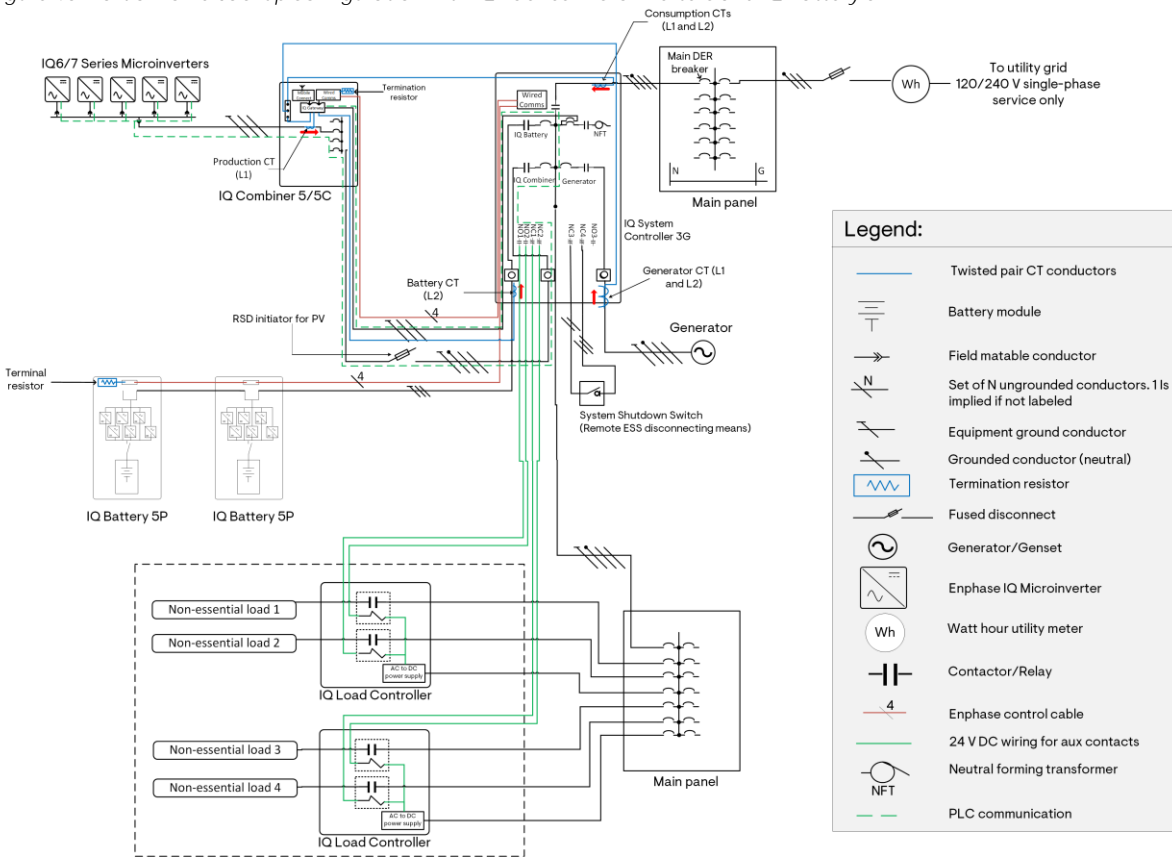

NOTES:

1. The IQ System Controller 3G can support up to 40 kWh IQ Battery 5P using the IQ Battery Oversubscription feature. Without battery oversubscription, the battery storage capacity is 20 kWh.
2. Hold-down kits need not be installed with breakers inside IQ Combiner 5/5C.

3. IQ System Controller 3/3G has an integrated hold-down kit and is compatible with Eaton, ABB/GE, and Siemens breakers for DERs.
4. The rated continuous power output of the microinverter array must not exceed 150% of the IQ Battery array's rated power output. If the microinverter array exceeds this ratio, PV load shedding must be implemented to shed excess PV when the system transitions to off-grid mode.
5. The generator power rating must be at least 143% of the IQ Battery array continuous power rating. Refer to the [Generator sizing](#) section for details.
6. Refer to the [Generator integration technical brief](#) for generator integration, operating modes, system commissioning, etc.
7. To monitor the consumption from the generator, systems with a generator will require an additional pair of generator CTs linked in parallel with the Consumption CTs. These CTs (2x CT-200-CLAMP or 2x CT-200-SPLIT) must be purchased separately.
8. The System Shutdown Switch is not the rapid shutdown initiator for PV. The PV breakers inside the IQ Combiner or PV sub-panel can be used as the rapid shutdown initiator if the NEC code adopted does not specify a single initiator. If the NEC code mandates a single initiator and if the IQ System Controller is readily accessible, the aggregate PV breaker inside the IQ System Controller can act as the rapid shutdown initiator. If it is not readily accessible, a disconnect must be installed between the IQ System Controller and IQ Combiner 5C/PV sub-panel to function as the PV rapid shutdown disconnect.



NOTE: IQ System Controller's door is lockable, enabling it to be locked when the breaker is off for safety.

9. The System Shutdown Switch can be used as a remote ESS disconnecting means where required.
10. The diagram does not show a remote start for the generator. Refer to [Appendix B](#) for details.

With M Series Microinverters, COMMS-KIT-02, and IQ System Controller 3

Figure 46: Partial home backup configuration with M Series Microinverters and IQ Battery 5P

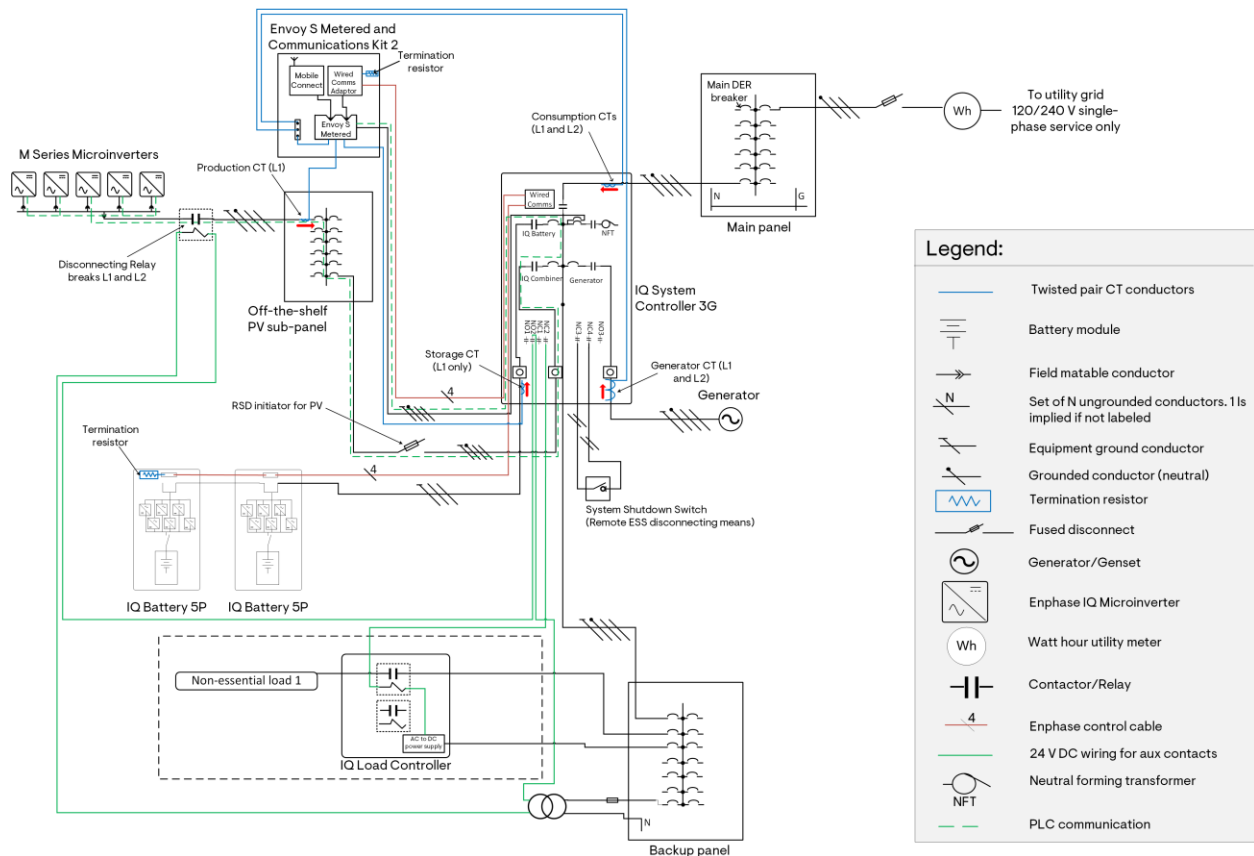

NOTES:

1. Use a jumper cable to shorten the L2 and L3 terminals in the Envoy S Metered power terminal. These are marked “B” and “C” respectively.
2. The IQ System Controller 3G can support up to 40 kWh IQ Battery 5P using the IQ Battery Oversubscription feature. Without battery oversubscription, the battery storage capacity is 20 kWh.
3. Hold-down kits need not be installed with breakers inside IQ Combiner 5/5C.
4. IQ System Controller 3/3G has an integrated hold-down kit and is compatible with Eaton, ABB/GE, and Siemens breakers for DERs.
5. The rated continuous power output of the microinverter array must not exceed 150% of the IQ Battery array’s rated power output.
6. PV shedding must be implemented to shed the microinverter array when the generator is connected to the microgrid and producing power. Refer to the [Generator integration technical brief](#) for details on PV shedding implementation.
7. Refer to the [Generator integration technical brief](#) for generator integration, operating modes, system commissioning, etc.
8. To monitor the consumption from the generator, systems with a generator will require an additional pair of generator CTs linked in parallel with the Consumption CTs. These CTs (2x CT-200-CLAMP or 2x CT-200-SPLIT) must be purchased separately.
9. The System Shutdown Switch is not the rapid shutdown initiator for PV. The PV breakers inside the IQ Combiner or PV sub-panel can be used as the rapid shutdown initiator if the NEC code

adopted does not specify a single initiator. If the NEC code mandates a single initiator and if the IQ System Controller is readily accessible, the aggregate PV breaker inside the IQ System Controller can act as the rapid shutdown initiator. If it is not readily accessible, a disconnect must be installed between the IQ System Controller and IQ Combiner 5C/PV sub-panel to function as the PV rapid shutdown disconnect.



NOTE: IQ System Controller’s door is lockable, enabling it to be locked when the breaker is off for safety.

10. The System Shutdown Switch can be used as a remote ESS disconnecting means where required.
11. The diagram does not show a remote start for the generator. Refer to [Appendix B](#) for details.

With IQ Battery 3/3T/10/10T

With IQ8 Series Microinverters, IQ Combiner 4/4C and IQ System Controller 2

Figure 47: Partial home backup configuration with IQ8 Series Microinverters and IQ Battery 3T/10T

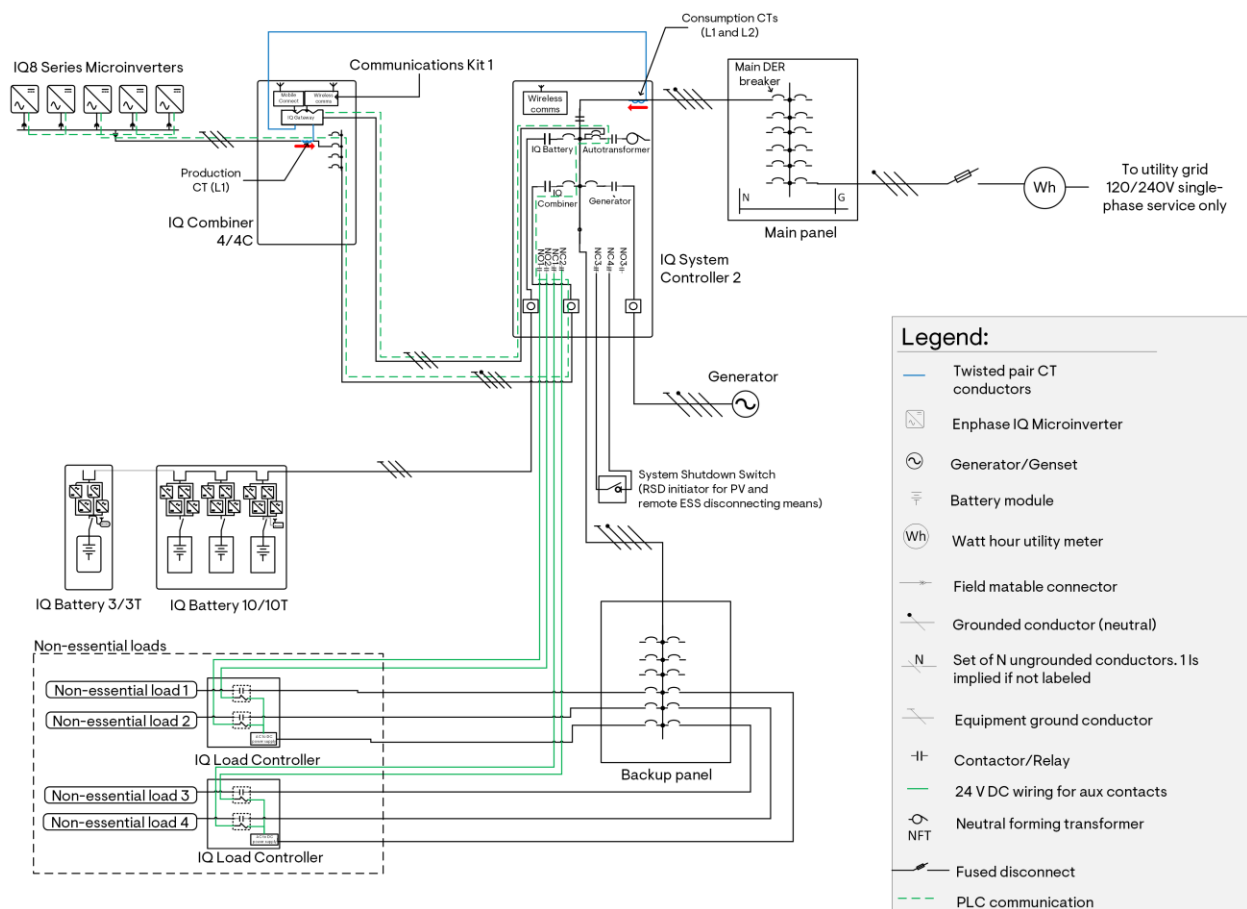

NOTES:

1. The IQ System Controller 2 can support up to 40 kWh IQ Battery 3T/10T.
2. Hold-down kits must be installed with breakers inside IQ Combiner 4/4C.
3. The generator power rating must be at least 143% of the IQ Battery array continuous power rating or 100% of the microinverter array continuous power rating, whichever is higher. Refer to the [Generator sizing](#) section for details.

4. Refer to the [Generator integration technical brief](#) for generator integration, operating modes, system commissioning, etc.
5. The System Shutdown Switch is the rapid shutdown initiator for PV. The System Shutdown Switch can be used as a remote ESS disconnecting means where required.
6. If more than 48 IQ8 Series Microinverters are installed in a system with a single IQ Battery 3T, implement PV shedding to remove additional PV from the microgrid or add additional batteries.
7. If more than 64 A of IQ8 Series Microinverters need to be installed, the excess PV must be split into a grid-tied system.
8. The diagram does not show a remote start for the generator. Refer to [Appendix B](#) for details.

With IQ6/7 Series Microinverters, IQ Combiner 4/4C and IQ System Controller 2

Figure 48: Partial home backup configuration with IQ6/7 Series Microinverters and IQ Battery 3/3T/10/10T

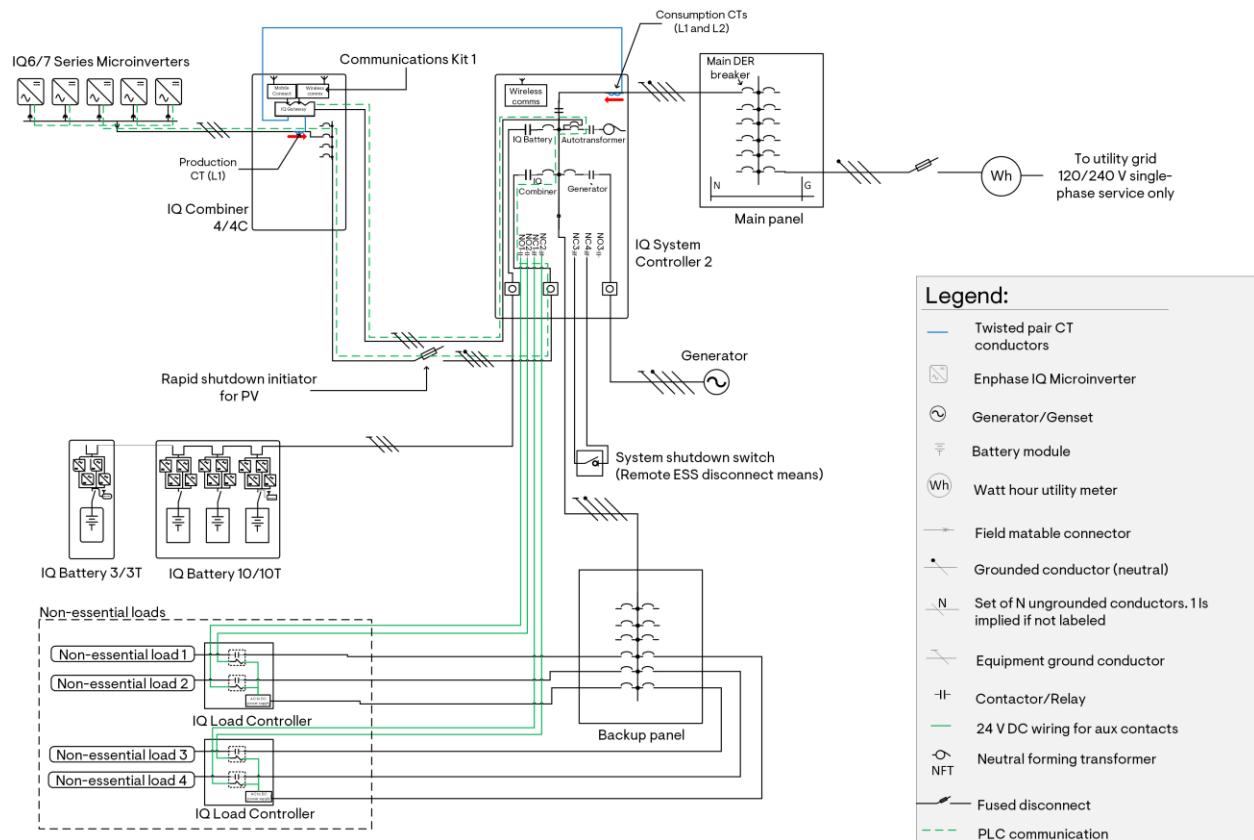

NOTES:

1. EES systems using IQ System Controller 2 and IQ Battery 3T/10T can support battery storage of up to 40 kWh.
2. The rated continuous power output of the microinverter array must not exceed 150% of the IQ Battery array’s rated power output. If the microinverter array exceeds this ratio, PV load shedding must be implemented to shed excess PV when the system transitions to off-grid mode.
3. The generator power rating must be at least 143% of the IQ Battery array continuous power rating. Refer to the [Generator sizing](#) section for details.
4. Refer to the [Generator integration technical brief](#) for generator integration, operating modes, system commissioning, etc.
5. The System Shutdown Switch can be used as a remote ESS disconnecting means where required.

- The System Shutdown Switch is not the rapid shutdown initiator for PV. The PV breakers inside the IQ Combiner or PV sub-panel can be used as the rapid shutdown initiator if the NEC code adopted does not specify a single initiator. If the NEC code mandates a single initiator and if the IQ System Controller is readily accessible, the aggregate PV breaker inside the IQ System Controller can act as the rapid shutdown initiator. If it is not readily accessible, a disconnect must be installed between the IQ System Controller and IQ Combiner 5C/PV sub-panel to function as the PV rapid shutdown disconnect.



NOTE: IQ System Controller’s door is lockable, enabling it to be locked when the breaker is off for safety.

- IQ Battery 3/3T/10/10T requires the use of hold-down kits on IQ System Controller 2.
- The diagram does not show a remote start for the generator. Refer to [Appendix B](#) for details.

With M Series Microinverters, COMMS-KIT-01, and IQ System Controller 2

Figure 49: Partial home backup configuration with M Series Microinverters and IQ Battery 3/3T/10/10T

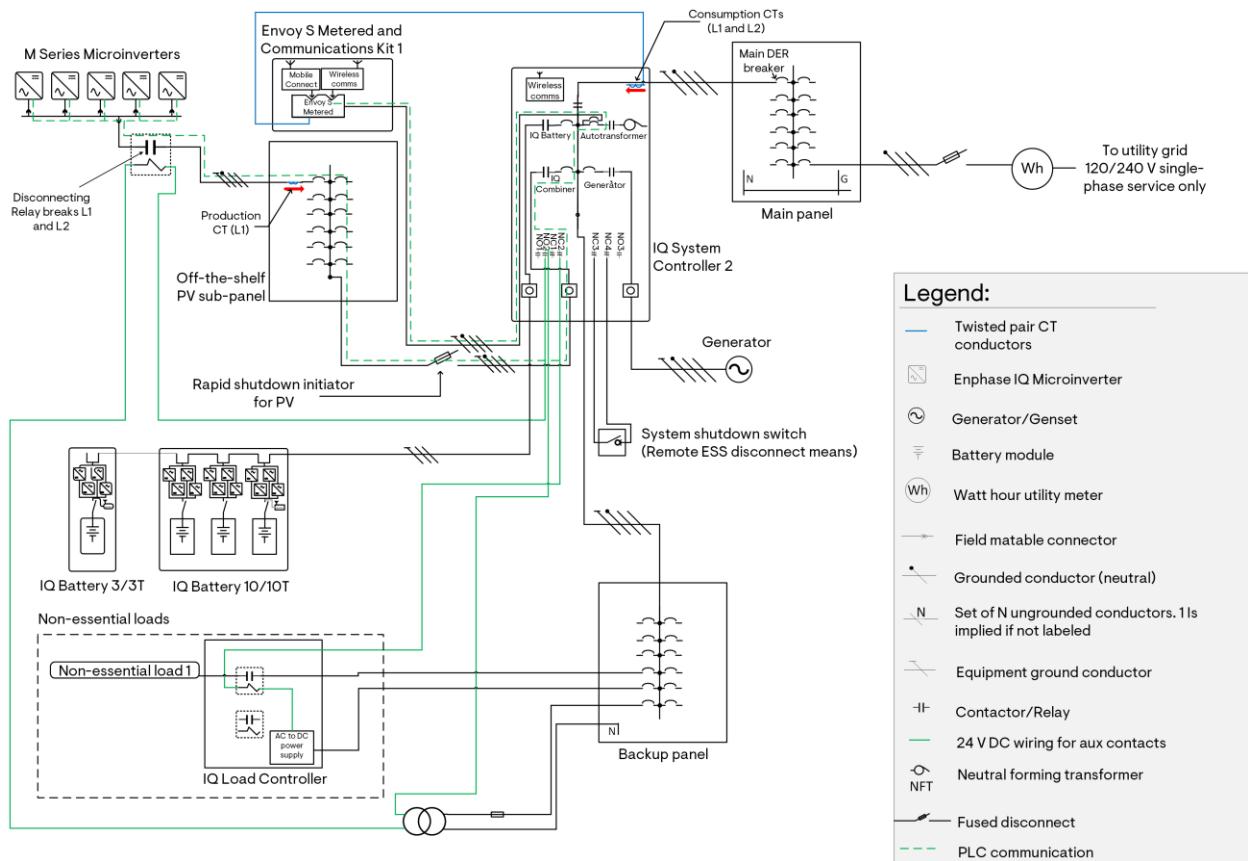

NOTES:

- EES systems using IQ System Controller 2 and IQ Battery 3T/10T can support battery storage of up to 40 kWh.
- The rated continuous power output of the microinverter array must not exceed 150% of the IQ Battery array’s rated power output.

3. PV shedding must be implemented to shed the microinverter array when the generator is connected to the microgrid and producing power. Refer to the [Generator integration technical brief](#) for details on PV shedding implementation.
4. The System Shutdown Switch can be used as a remote ESS disconnecting means where required.
5. The System Shutdown Switch is not the rapid shutdown initiator for PV. The PV breakers inside the IQ Combiner or PV sub-panel can be used as the rapid shutdown initiator if the NEC code adopted does not specify a single initiator. If the NEC code mandates a single initiator and if the IQ System Controller is readily accessible, the aggregate PV breaker inside the IQ System Controller can act as the rapid shutdown initiator. If it is not readily accessible, a disconnect must be installed between the IQ System Controller and IQ Combiner 5C/PV sub-panel to function as the PV rapid shutdown disconnect.



NOTE: IQ System Controller's door is lockable, enabling it to be locked when the breaker is off for safety. IQ Battery 3/3T/10/10T requires the use of hold-down kits on IQ System Controller 2.

6. The diagram does not show a remote start for the generator. Refer to [Appendix B](#) for details.

Control wiring

An Enphase Energy System using IQ System Controller 3/3G and IQ Battery 5P needs control cables to be wired between IQ Combiner 5/5C, Communications kit 2 (in case of systems with standalone IQ Gateway or Envoy S Metered), IQ System Controller 3/3G, and IQ Battery 5P.

The control cable required for IQ Battery 5P, IQ Combiner 5/5C, and IQ System Controller 3/3G must comply with UL 3003, UL 1277, and UL 83 standards.



NOTE: Enphase has validated performance using the Enphase control cable (SKU: CTRL-SC3-NA-01). Enphase cannot guarantee performance when a third-party control cable is used.



NOTE: Enphase control cable (SKU: CTRL-SC3-NA-01) can be routed along with the power cables in the same conduit.

Enphase control wiring has the following components:

1. The signal wires (two twisted pair wires) within the control cable (CTRL L = Blue, CTRL H = Orange, Ground = Black, NA = Red)
2. The drain wire of the shield
3. Termination resistor

Installation guidelines

Ensure the following guidelines are followed to avoid failures during system commissioning.

- At the end of the control network, each component should have one header fitted with a termination resistor.
- The drain wire should only be terminated on one end of the control wiring between system components.
- It is recommended that the drain wire be terminated at the component from which the control wiring for the section is initiated.

- The same conduits can be used for power and control wire routing only when using an Enphase CTRL cable (CTRL-SC3-NA-01).

Common Control wiring sequences

Figure 50: Control wiring sequence 1a: IQ Combiner 5/5C → IQ System Controller 3G → IQ Battery(s) 5P

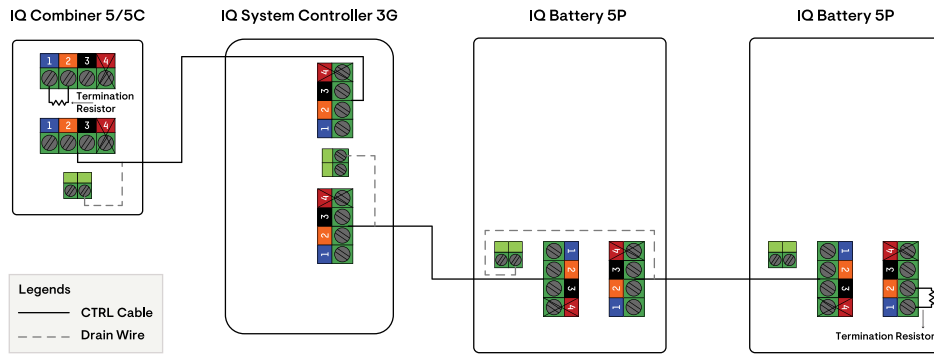

This only applies to IQ System Controller 3, where the third DER port can be used for an additional battery.

Figure 51: Control wiring sequence 1b: IQ Combiner 5/5C → IQ System Controller 3 → IQ Battery(s) 5P

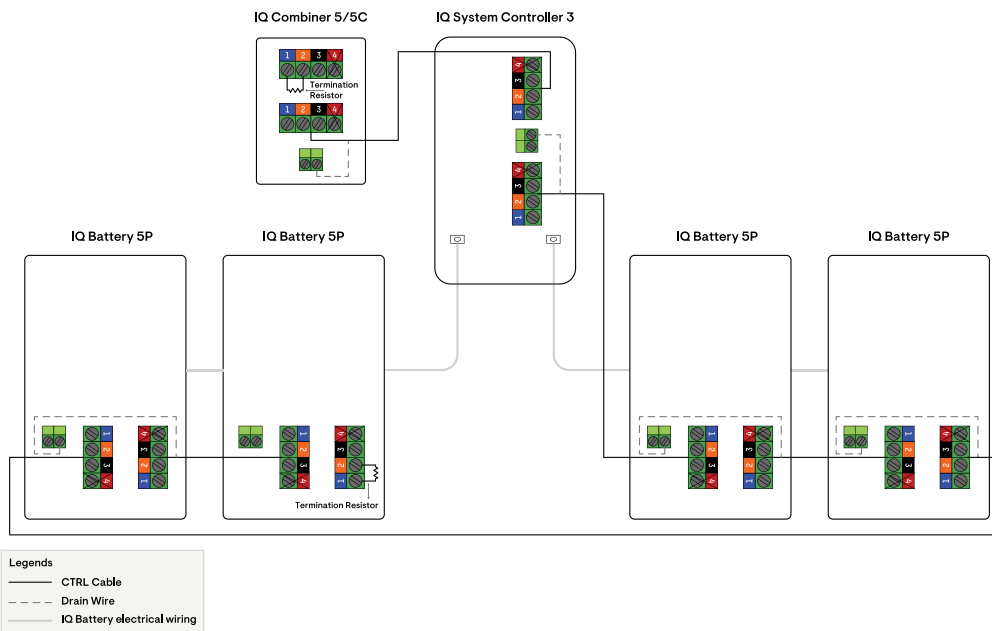

Figure 52: Control wiring sequence 2: IQ Combiner 5/5C → IQ Battery(s) 5P → IQ System Controller 3/3G

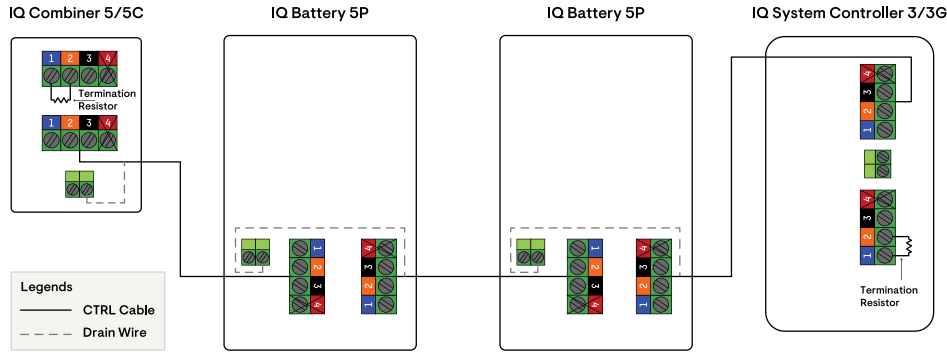

Figure 53: Control wiring Sequence 3: IQ System Controller 3/3G → IQ Combiner 5/5C → IQ Battery(s) 5P

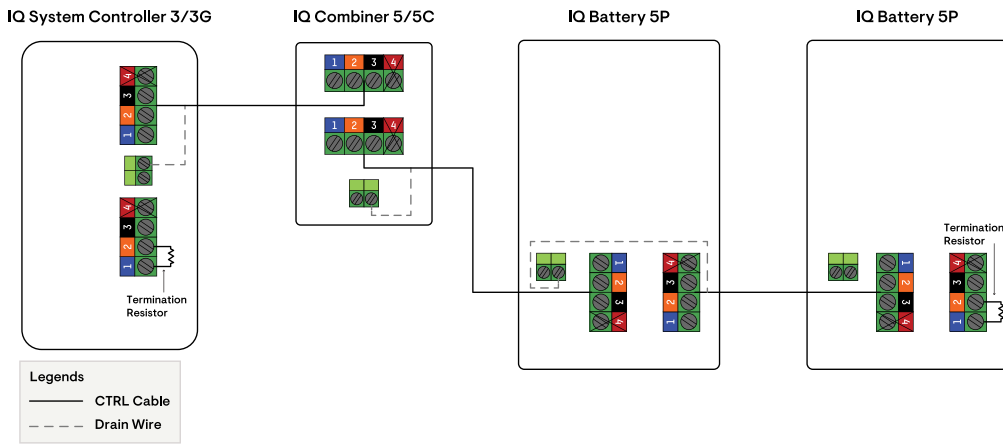

Table 19: Termination resistor location

Control wiring sequence	Termination resistor location
IQ Combiner 5/5C → IQ System Controller 3G → IQ Battery(s) 5P	IQ Combiner 5/5C Last IQ Battery 5P in the daisy chain
IQ Combiner 5/5C → IQ System Controller 3 → IQ Battery(s) 5P	IQ Combiner 5/5C Last IQ Battery 5P in the daisy chain
IQ Combiner 5/5C → IQ Battery(s) 5P → IQ System Controller 3/3G	IQ Combiner 5/5C IQ System Controller 3/3G
IQ System Controller 3/3G → IQ Combiner 5/5C → IQ Battery(s) 5P	IQ System Controller 3/3G Last IQ Battery 5P in the daisy chain

Preparing for the wiring

Step 1: Getting the right cable length

Each cable run must be cut to the required lengths based on the conduit lengths. Additional wire length is needed to ensure the control cable can be wired to the control ports in the respective devices. Refer to the respective device Quick Installation Guide for the additional cable length.

The total control cable length will equal the conduit length + additional wiring for the device at one end + additional wiring at the other end of the cable.

The total control cable length must be less than **75 meters (250 feet)**.



NOTE: Follow instructions in the device Quick Installation Guides while routing the control cable inside the devices.

Step 2: Stripping the cables that have been cut

The cable ends must be stripped to connect them to the headers. Refer to the device Quick Install Guide for the additional cable length needed.



NOTE: Cut the drain wire in the cable end, which is not connected to the header.

Step 3: Connecting cables to headers

The control cable connections to the header are as follows.

Figure 54: Control cable wiring instructions

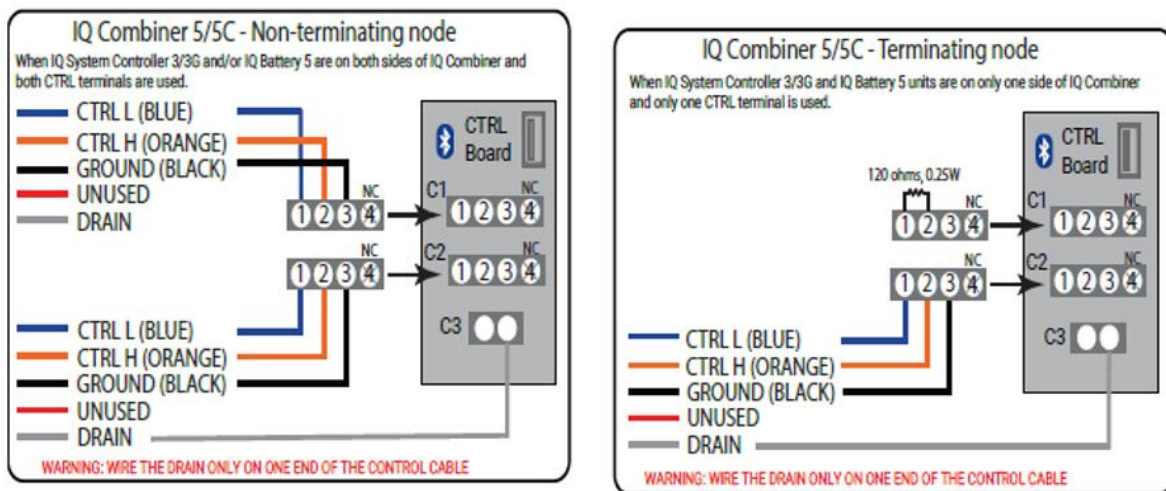

NOTE: These connections are standardized across all Enphase devices.



NOTE: Secure the unconnected drain wire to avoid accidental contact with other terminals or ground.

Electrical installation considerations

Voltage regulation considerations

When the IQ Battery 3T/10T/5P is charging, it acts like a load, and the voltage decreases at the battery’s terminals based on Ohm’s law and wire resistance. When the IQ Battery 3 T/10T/5P discharges to feed loads, it behaves like a source, and the voltage increases at the battery’s terminals.

The voltage rise to voltage drop delta divided by the nominal voltage is roughly equivalent to voltage regulation. Since the peak charge and discharge values for IQ Battery 3T/10T/5P are the same, voltage rise and voltage drop will be the same.

Voltage regulation in an Enphase Energy System is calculated as $Percent\ VR = \frac{2 \cdot |V_d|}{V_{nom}}$

where:

V_d is the voltage change from 0 to max current out of IQ Battery 3T/10T/5P, and
 V_{nom} is the nominal RMS voltage.

Ensure that the IQ Battery 3T/10T/5P conductors are sized correctly for the number of units on the circuit and that voltage regulation does not exceed 1% between the first IQ Battery 3T/10T/5P and IQ System Controller 3/3G.

Rapid shutdown of Enphase Energy System

2020 NEC 690.12 requires a rapid shutdown for PV systems on buildings by an initiation device in a readily accessible location. This is often the service disconnecting means, or PV system disconnects in grid-interactive systems. rapid shutdown requirements do not apply to optional standby systems such as energy storage, and, as seen in Figure 1, the PV system disconnect can still initiate rapid shutdown.

For an Enphase system using IQ6/7 Series and M215 and M250 Microinverters, the rapid shutdown initiation device can be either:

- The PV system breaker in IQ System Controller 3/3G.
- An additional disconnect, such as a fusible disconnect between IQ System Controller 3/3G and the IQ Combiner.
- The circuit breakers in the IQ Combiner since these breakers are fewer than six and grouped.

The rapid shutdown initiator must be labeled per 2017 NEC 690.56.

For an Enphase Energy System with IQ8 Series Microinverters in grid-agnostic mode, the **Enphase System Shutdown Switch (EP200G-NA-02-RSD)** must be installed with IQ System Controller 3/3G to act as the only rapid shutdown device of the system. Refer to the [Quick Installation Guide of Enphase System Shutdown Switch](#) for instructions on wiring the rapid shutdown device.

WARNING: IQ System Controller 3/3G and Enphase System Shutdown Switch can enforce rapid shutdown **ONLY** on IQ8 Series Microinverters connected to the IQ System Controller 3/3G AC Combiner port.

Abbreviations

Abbreviation	Description
DER	Distributed energy resource
ESS	Energy storage system
kW	Kilowatt
kVA	Kilovolt-ampere
MID	Microgrid interconnect device
NEC	National electric code
NFT	Neutral forming transformer
OCPD	Overcurrent protection device
PV	Photo voltaic
RSD	Rapid shutdown device
RDE	Rapid shutdown equipment
SKU	Stock keeping unit

Appendix A

Other supported configurations

Grid-tied configurations

Solar Only grid-tied configuration with IQ8/IQ6/IQ7 Series Microinverters, IQ Gateway and off-the-shelf combiner box

In a Solar Only configuration, if the sum of maximum current from the IQ8/IQ7/IQ6 PV branches is greater than 80 A, an appropriately sized third-party combiner box can be paired with the IQ Gateway.

Figure 55: Solar Only grid-tied configuration with IQ7/IQ8/IQ6 Microinverters, IQ Gateway and third-party combiner box

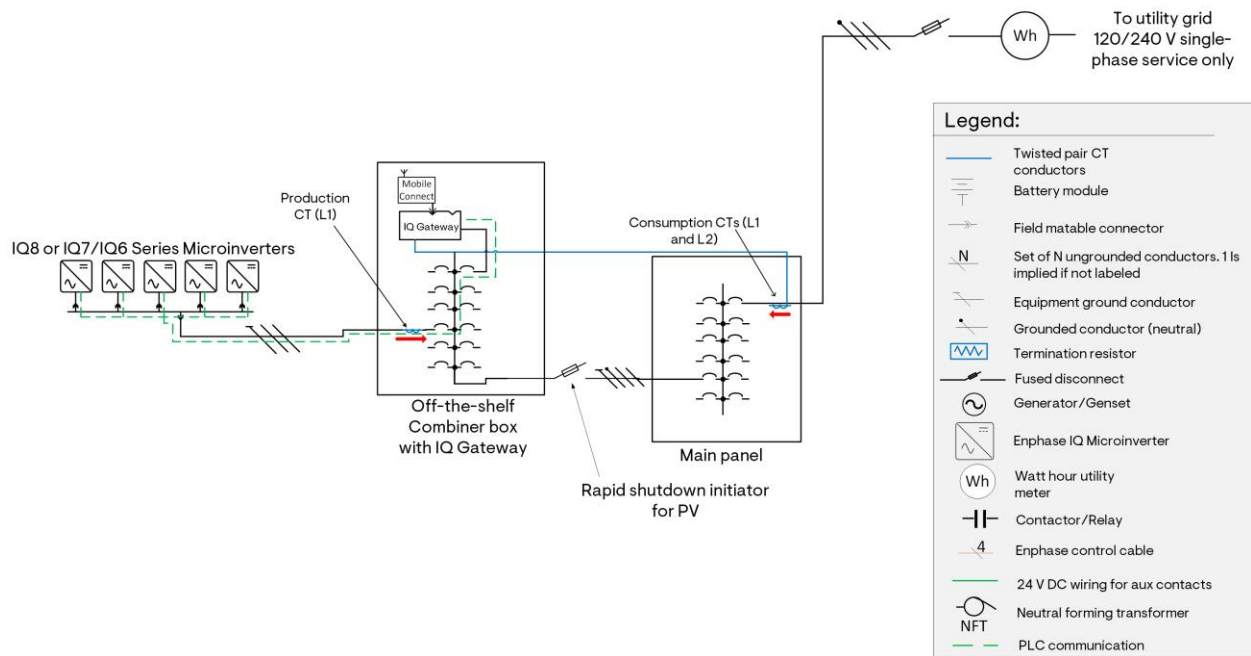

NOTES:

- Systems with IQ8 Series Microinverters must contain only.
- IQ8 Series Microinverters are incompatible with previous generations of Enphase microinverters, such as IQ6, IQ7, and M Series Microinverters, and cannot be installed together. This applies to all system configurations, with and without storage.
- IQ Gateway and Mobile Connect cell modems must be purchased separately and can be housed in the off-the-shelf combiner box or any other enclosure.
- The main DER breaker (aggregate PV breaker on the main panel) can act as the rapid shutdown initiator for PV in grid-tied configuration if it is readily accessible.

Solar + Battery grid-tied configuration with IQ8/IQ6/IQ7 Series Microinverters, IQ Battery 5P and off-the-shelf DER sub-panel

If the sum of the maximum current from the PV branches and the two IQ Battery 5P branches is greater than 80 A, an appropriately sized third-party combiner box must be used.

Figure 56: Solar + Battery grid-tied configuration with IQ8/IQ7/IQ6 Microinverters, IQ Battery 5P, Enphase COMMS-KIT-02, Mobile Connect cell modem and off-the-shelf combiner box

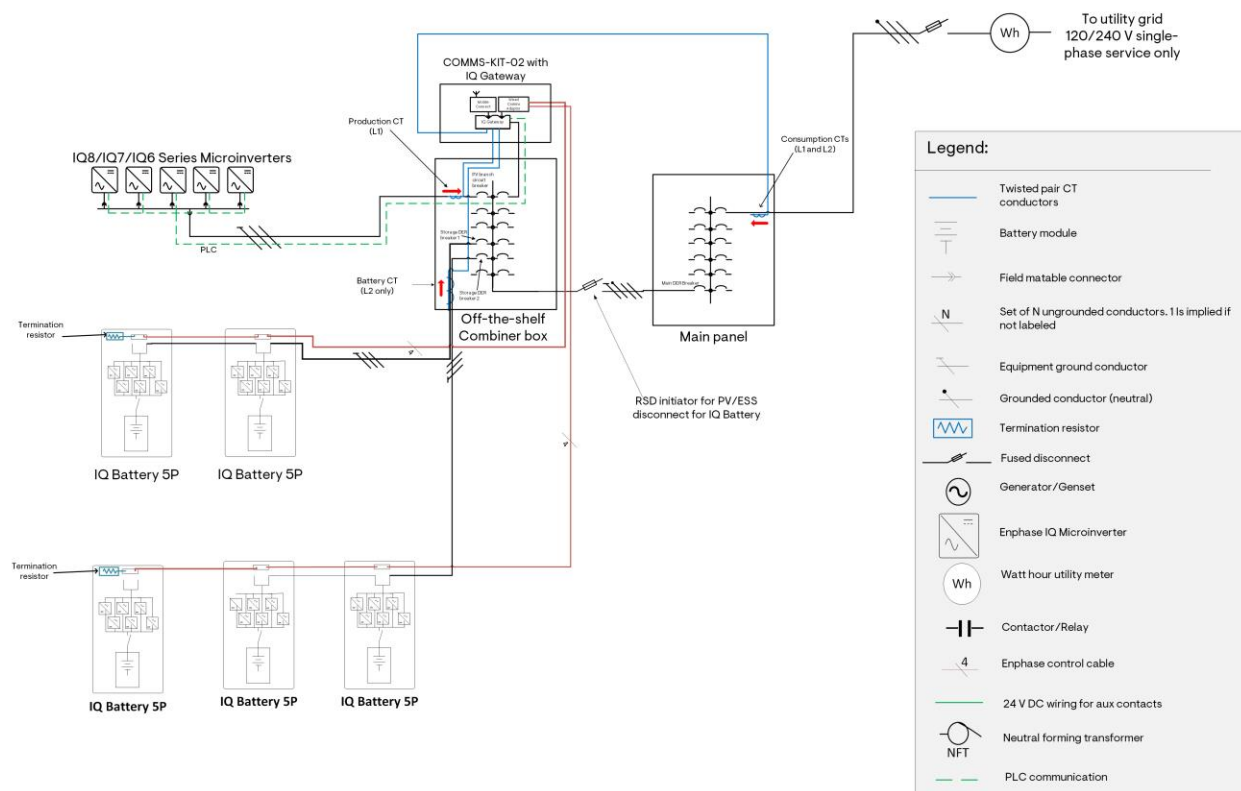

NOTES:

- Systems with IQ8 Series Microinverters must contain only IQ8 Series Microinverters as they are incompatible with older generations of Enphase microinverters, including IQ6 and IQ7 Series Microinverters. This applies to all system configurations, with and without storage.
- IQ Gateway and Mobile Connect can be housed in the COMMS-KIT-02 box. The IQ Gateway and Mobile Connect cell modem must be purchased independently from the COMMS-KIT-02.
- Systems with IQ Battery 5P require an IQ Gateway software version of 8.X or later. If an update is needed, it will be automatically applied during the commissioning process.
- The battery Current Transformer (CT) must clamp L2 conductors on both IQ Battery 5P branches.
- The main DER breaker (off-the-shelf combiner box breaker on the main panel) can act as the rapid shutdown initiator for PV AND ESS disconnecting means in grid-tied configuration if it is readily accessible.

Battery Only grid-tied configuration IQ Battery 5P, IQ Gateway and Communications Kit 2 off-the-shelf sub-panel and two battery circuits

Figure 57: Battery Only grid-tied configuration with one IQ Battery 5P on Storage DER breaker 1 and two IQ Battery 5P on Storage DER breaker 2 of a third-party combiner box along with COMMS-KIT-02 and IQ Gateway

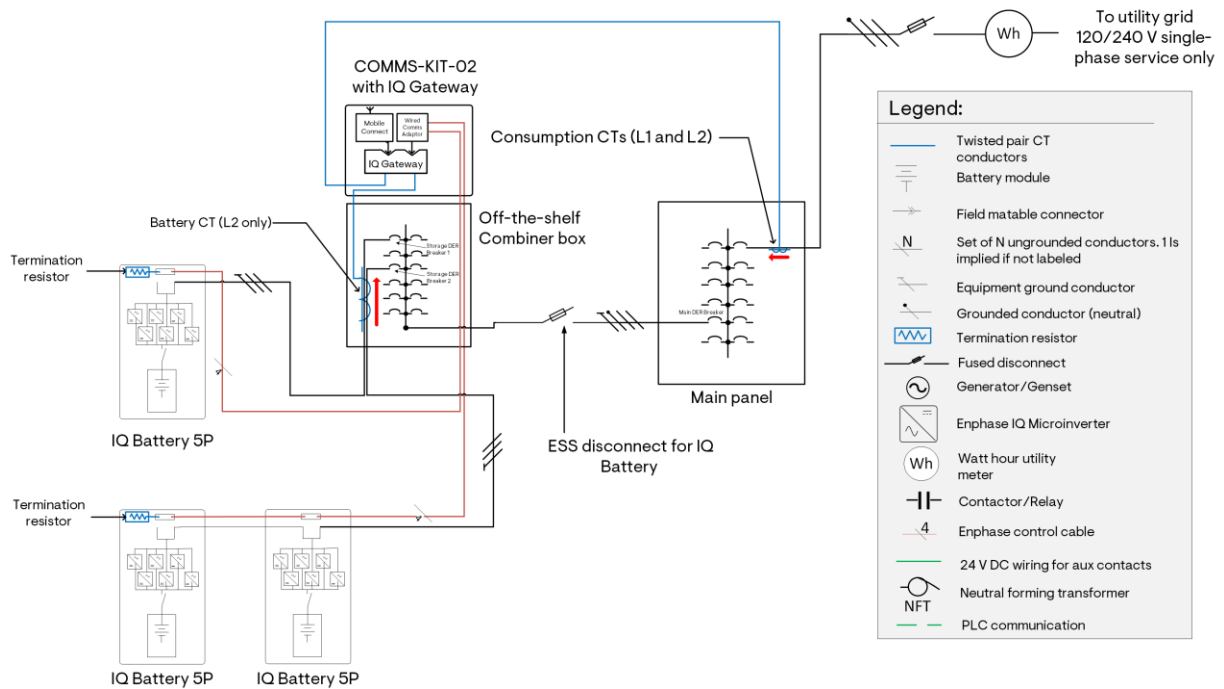

Appendix B

Figure 58: Generator auxiliary contact wiring for two-wire remote-start generator

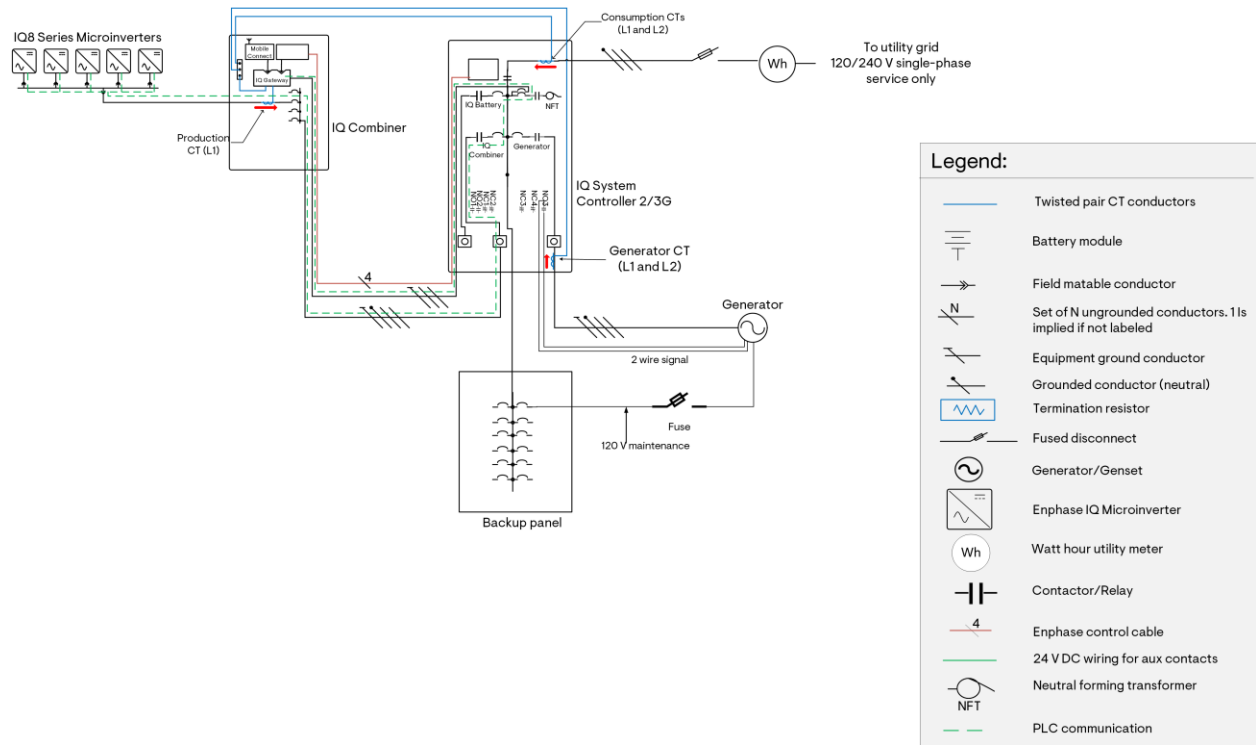
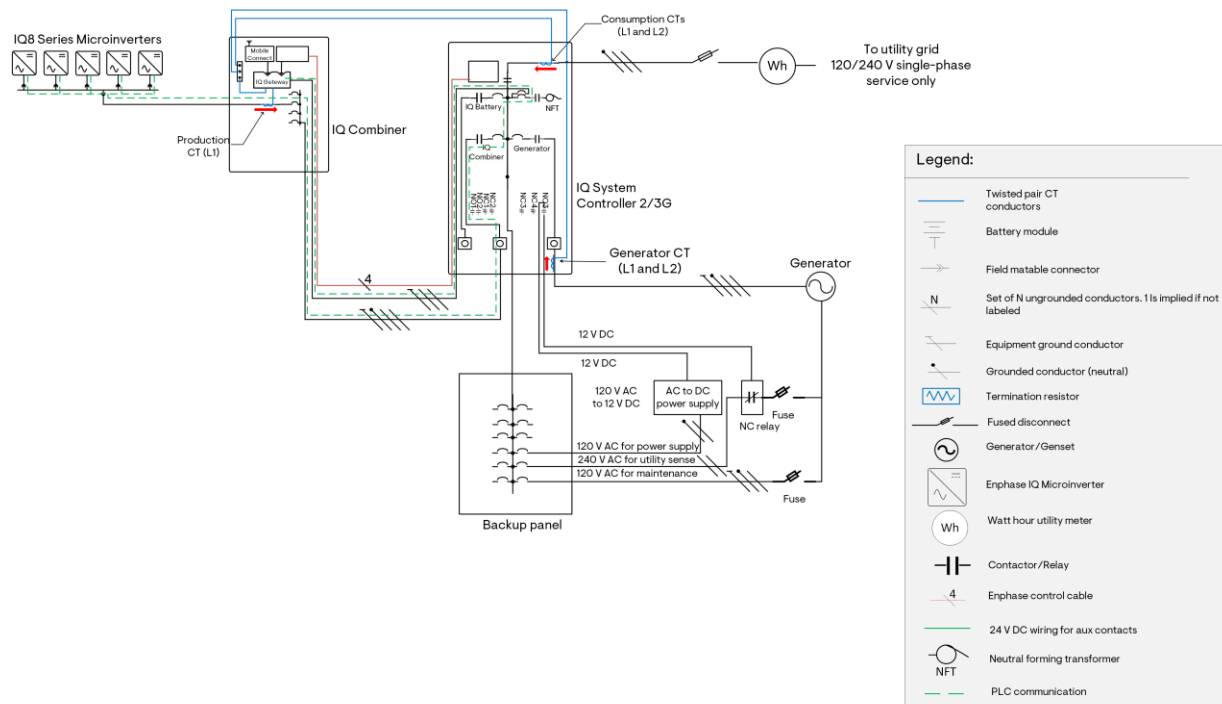

Figure 59: Generator auxiliary contact wiring for utility sense-based remote-start generator



Appendix C

Split Enphase Systems on a single site with IQ6/IQ7/IQ8 or M Series Microinverters

It is necessary to “split” the PV systems into a microgrid and a non-microgrid PV system, each with its own IQ Gateway, in the following scenarios:

1. Prevent mixing of multiple microinverter series – Due to technical limitations, M Series Microinverters cannot be installed in the same system as IQ6/IQ7 Series Microinverters. Similarly, IQ6/IQ7 Series Microinverters cannot be installed with IQ8 Series Microinverters.
2. IQ8 Series Microinverter output exceeding 64 A continuous at the site – IQ System Controller 2 supports only 64 A continuous PV at the AC combiner port. If the PV array exceeds 64 A continuous output, the installer can configure an additional grid-tied system with an IQ Gateway/IQ Combiner 3/3C/4/4C.



WARNING: Each system’s communication must be isolated from the other systems. The isolation involves the guidelines described and illustrated in subsequent diagrams.

- PLC communication occurs in AC cables at very high frequencies (over 100 KHz) and can inductively couple to any adjacent cable running in the same conduit or duct. Such coupling is avoided by physically separating cables from different domains or running them in separate grounded conduits. Where grounded conduits cannot be installed, these cables need to be physically separated by at least 3.3 feet/1 meter.
- PLC coupling may occur when multiple Enphase systems share a common AC line (for example, installed on the same main load panel at a home or installed behind the same distribution transformer in different homes). A PLC line filter installed between two systems will prevent such coupling.
- Never install a PLC line filter between an IQ Gateway and the microinverters. It will prevent the PLC communication between the microinverters and the IQ Gateway and will impact system functioning.



NOTE: We no longer recommend splitting the system if the total PV system size exceeds what can be supported by the total IQ Battery system size. PV shedding shall be used to address this scenario. For guidance on PV system size pairing with an IQ Battery, see the section [Relationship between microinverter and IQ Battery sizing in grid-forming systems](#).



NOTE: This configuration does not support power export limiting.

The following items are needed to create a split system.

1. Two Gateways:
 - Multiple IQ Gateways (or Envoy S Metered for M Series Microinverters) are required for split systems because the microgrid and non-microgrid PV microinverters operate with different grid profiles and parameters.

2. Installation of a power line filter:

- When multiple IQ Gateways exist on site, a power line filter must be installed to prevent cross-domain communication.
- The [Q-LCF-064-1P](#) is a tested solution compatible with Enphase IQ6/IQ7/IQ8 Series Microinverters and IQ Gateway for up to 64 A of continuous current.
- Similarly, the [RP220](#), [RP225](#), [RP230](#), or [RP240](#) Series from Radius Power can be used with M215/M250 Microinverters and the Envoy S Metered.
- For systems with IQ6, IQ7, and M Series Microinverters, Enphase recommends installing the power line filter with the microgrid IQ Gateway and all microgrid PV microinverters on the “Load” input of the filter and the IQ System Controller 1 or IQ System Controller 2 PV DER on the “Line” input of the filter.
- For systems with IQ8 Series Microinverters in a microgrid, the PLC path between the microgrid’s IQ Gateway and the microgrid microinverters passes through the IQ System Controller 2. So, the PLC line filter cannot be installed between the IQ System Controller 2 and the microgrid microinverters. Moreover, only Q-LCF-064-1P provides adequate isolation for an IQ8 Series Microinverter-based system. Because of the constraints, the power line filter must be installed only between the non-microgrid system and the main load center, irrespective of the microinverter type in the non-microgrid system. **Install the power line filter with the non-microgrid IQ Gateway and all microgrid PV microinverters on the “Load” input of the filter and the main load center on the “Line” input.**

Table 20: PLC line filter configuration for systems with IQ8 Series Microinverters in microgrid

No.	Microgrid microinverter series	Non-microgrid microinverter series	Filter position	PLC line filter SKU
1	IQ8 Series	IQ8 Series	Between the non-microgrid system and the main load center	Q-LCF-064-1P
2	IQ8 Series	IQ6/IQ7 Series	Between the non-microgrid system and the main load center	Q-LCF-064-1P
3	IQ8 Series	M Series	Between the non-microgrid system and the main load center	RP220, RP225, RP230, or RP240

3. Installation of additional Consumption CTs:

- Depending on the configuration of the split system, an additional pair of Consumption CTs may need to be added. The Consumption CTs in split systems can be installed in the following configurations. The system behavior in these configurations will be different:

Table 21: CT placement and behavior of split system configurations

Location of microgrid Consumption CTs	Location where non-microgrid PV interconnects	Additional Consumption CTs	System behavior	Reference line diagram
Between the main panel and energy meter	Load side of microgrid Consumption CT or in the main panel	Yes	If using Self-Consumption or Savings battery profiles in the scenario illustrated in the figures mentioned alongside, the battery is	Figure 60 , Figure 61 , Figure 62 , Figure 66 , Figure 67 , Figure 68

Location of microgrid Consumption CTs	Location where non-microgrid PV interconnects	Additional Consumption CTs	System behavior	Reference line diagram
Between the main panel and energy meter	Line side of microgrid Consumption CT	No	prioritized to discharge to serve loads on the main panel, and the grid-tied PV is dispositioned to export to the grid.	Figure 63 , Figure 64 , Figure 65
Between IQ System Controller and main panel	In the main panel	No	The battery is prioritized to discharge only to serve loads on the backup panel, and the grid-tied PV is dispositioned to serve loads on the main panel or to export to the grid.	Figure 66 , Figure 67 , Figure 68



GENERAL NOTE: The single-line diagrams in this appendix represent a system with IQ System Controller 3 and IQ Battery 5P. However, even systems using IQ System Controller 2, IQ Combiner 4/4C, and IQ Battery 3/3T/10/10T will exhibit the same behavior if the CT placements are similar.

Split systems with additional Consumption CTs

If the non-microgrid PV system is interconnected on the load side of the primary microgrid IQ Gateway’s Consumption CT, a second set of Consumption CTs must be added around the non-microgrid PV conductors and connected in parallel with the primary microgrid Consumption CT wiring to the microgrid IQ Gateway. Refer to [Figure 60](#) for more details and the orientation of the CTs.



GENERAL NOTE: When using Self-Consumption or Savings battery profiles in the scenario illustrated here, the battery is prioritized to discharge to serve loads on the main panel, and the grid-tied PV is dispositioned to export to the grid. To avoid this behavior, look at the alternate system configurations provided in [Figure 66](#), [Figure 67](#), and [Figure 68](#).

Figure 60: "Split" IQ8 PV system with an additional set of Consumption CTs

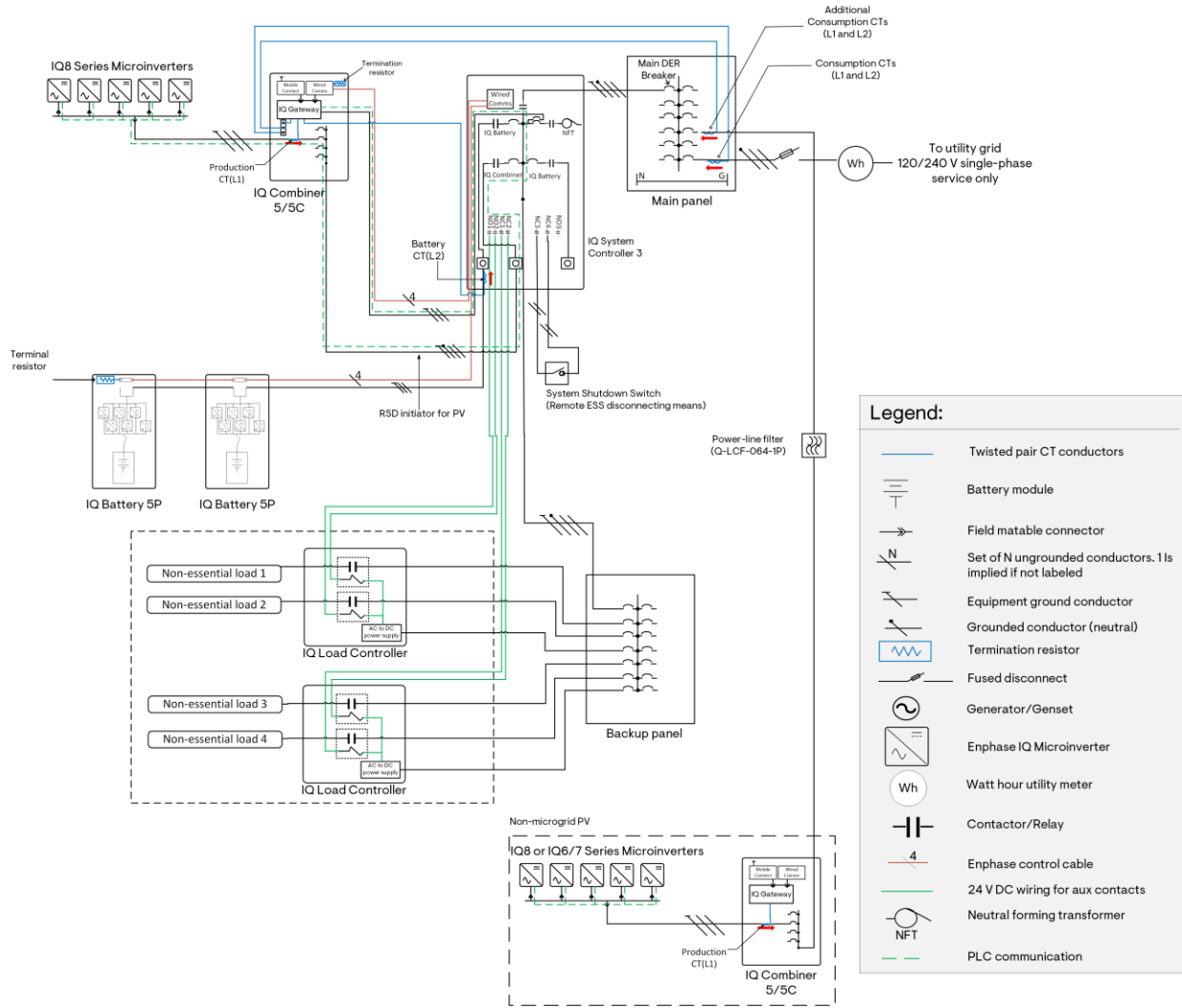

Figure 61: "Split" IQ6/IQ7 PV system with an additional set of Consumption CTs

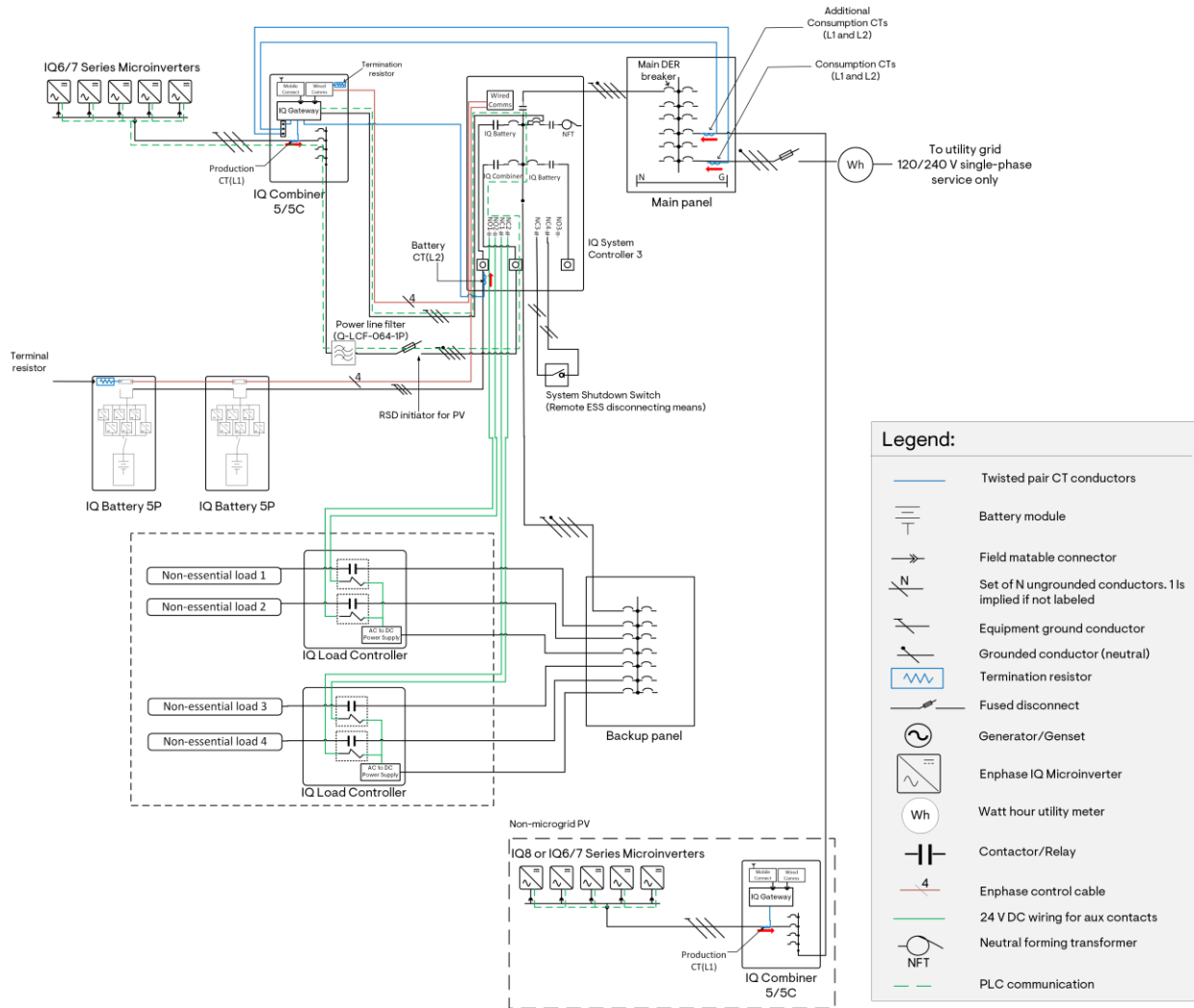
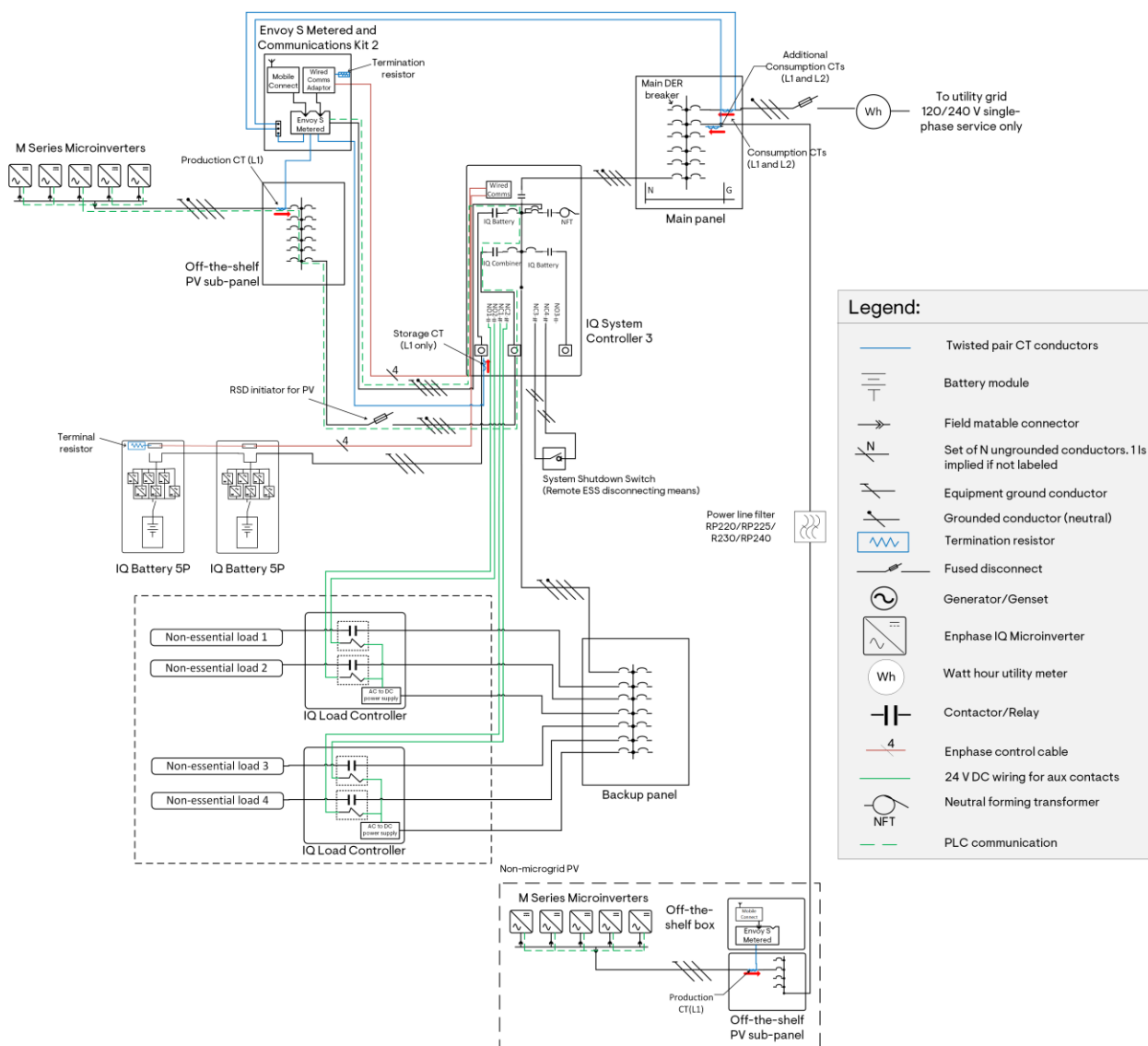

Figure 62: “Split” M Series PV system with an additional set of Consumption CTs



Split systems without additional Consumption CTs

For Enphase Energy Systems, where the non-microgrid PV system is interconnected on the utility side of the primary microgrid Gateway’s Consumption CTs, no additional Consumption CTs are needed. See [Figure 63](#) for this configuration.

Figure 63: "Split" IQ6/IQ7 Series PV system without an additional set of Consumption CTs

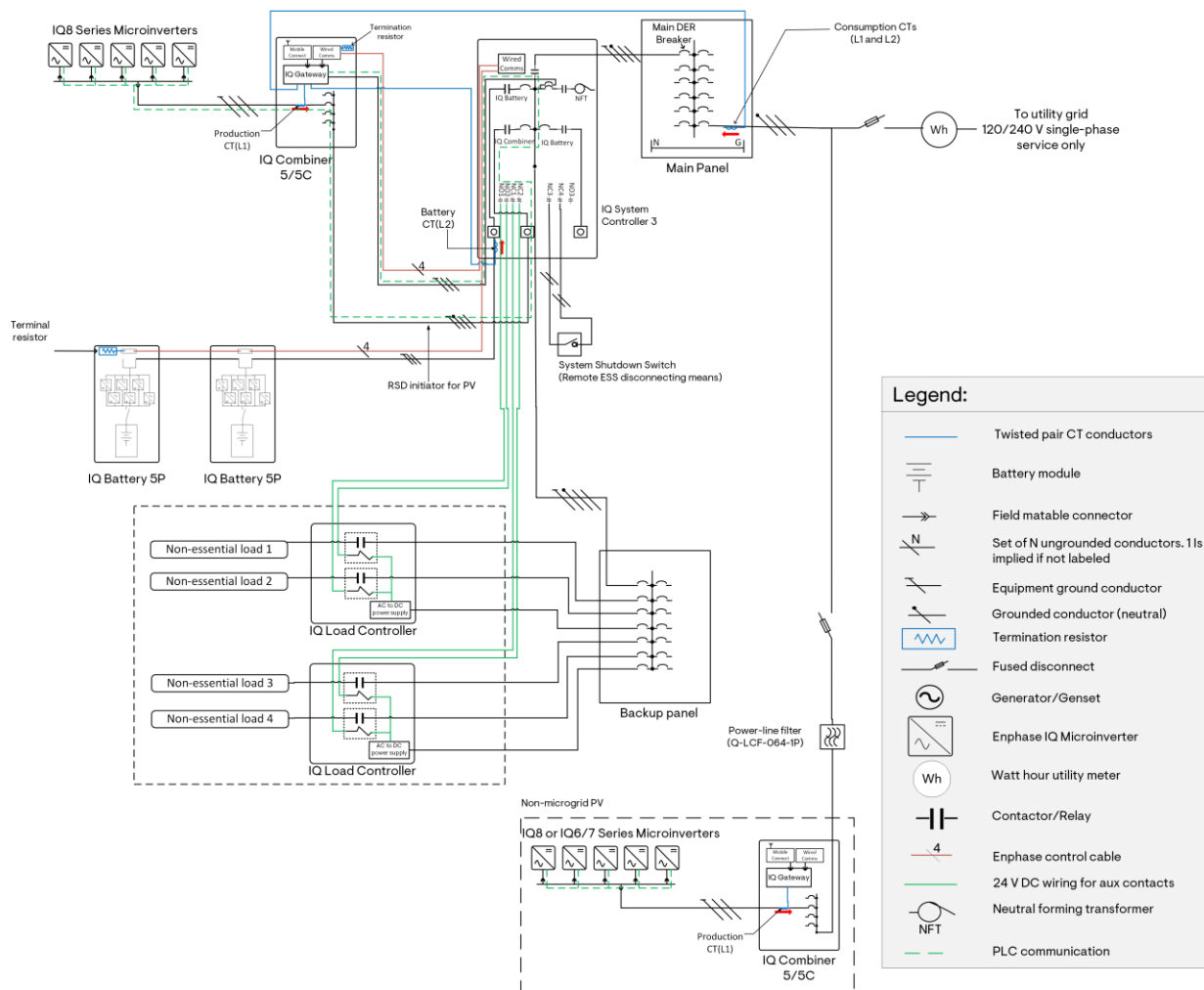

Figure 64: "Split" M Series PV system without an additional set of Consumption CTs

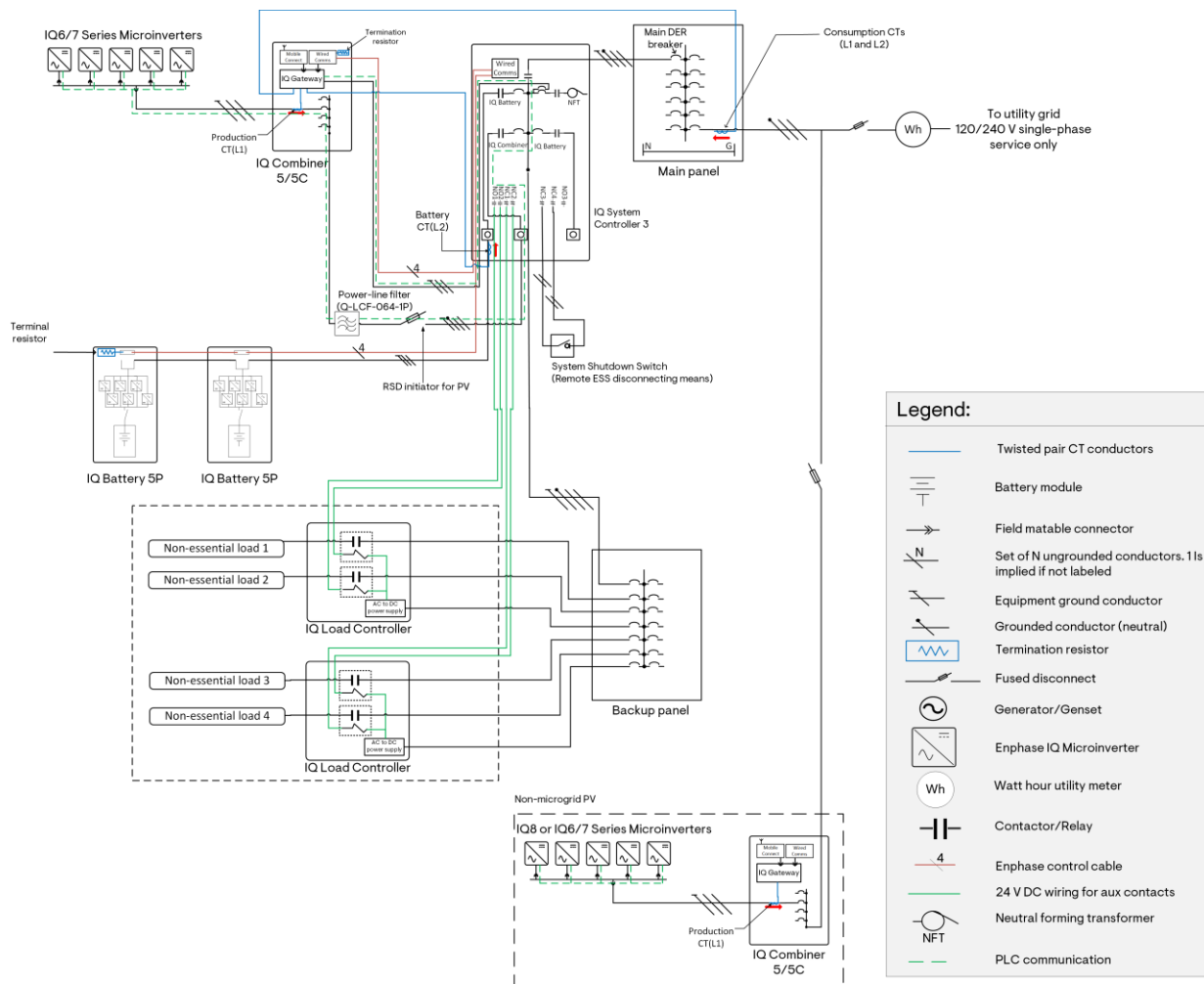
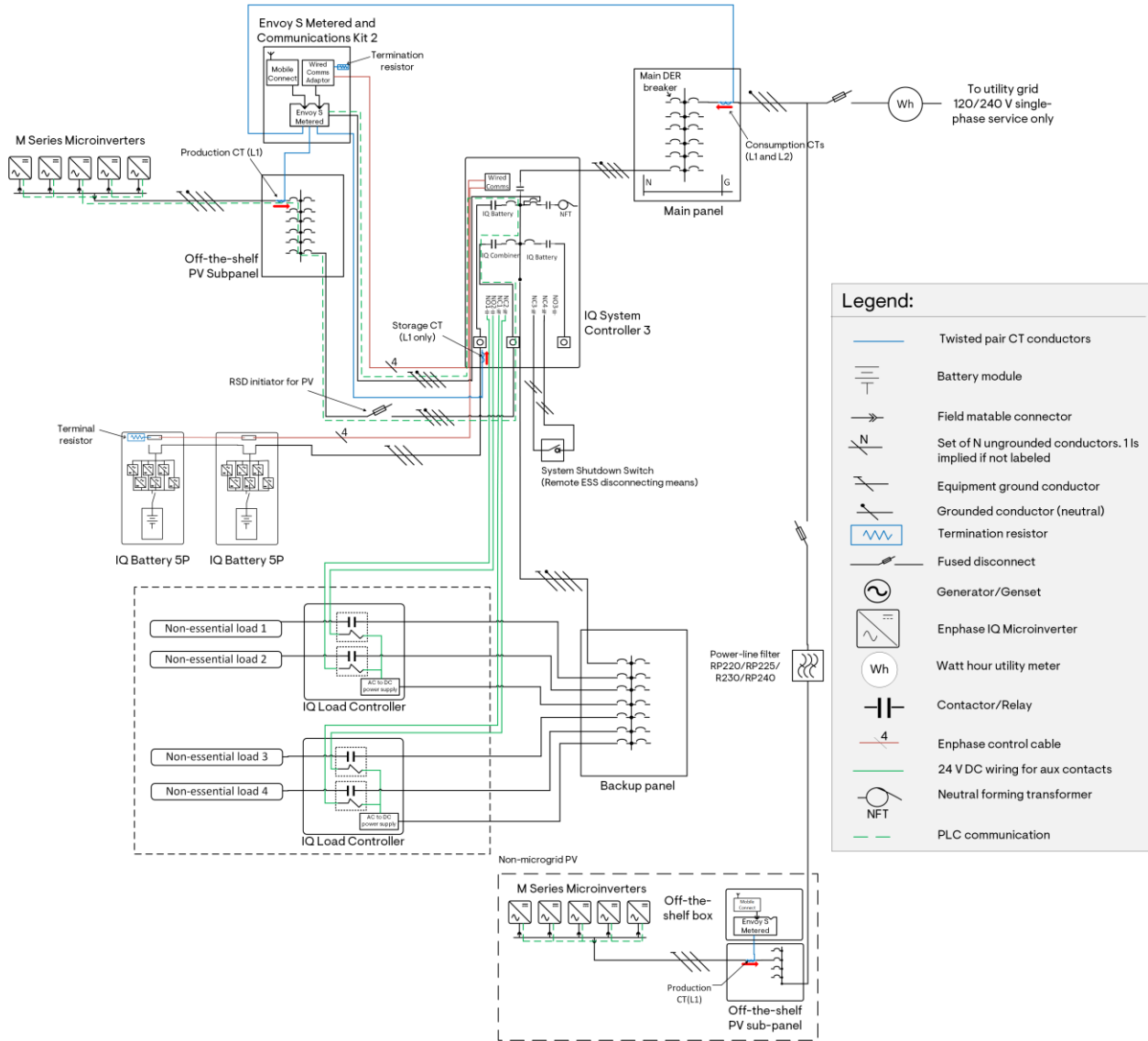

Figure 65: "Split" IQ8 Series PV system without an additional set of Consumption CTs



Split system without additional Consumption CTs where batteries prioritize backup loads only

Figure 66: “Split” PV system without an additional set of Consumption CTs – Configuration to prevent the battery from discharging to serve loads on the main panel

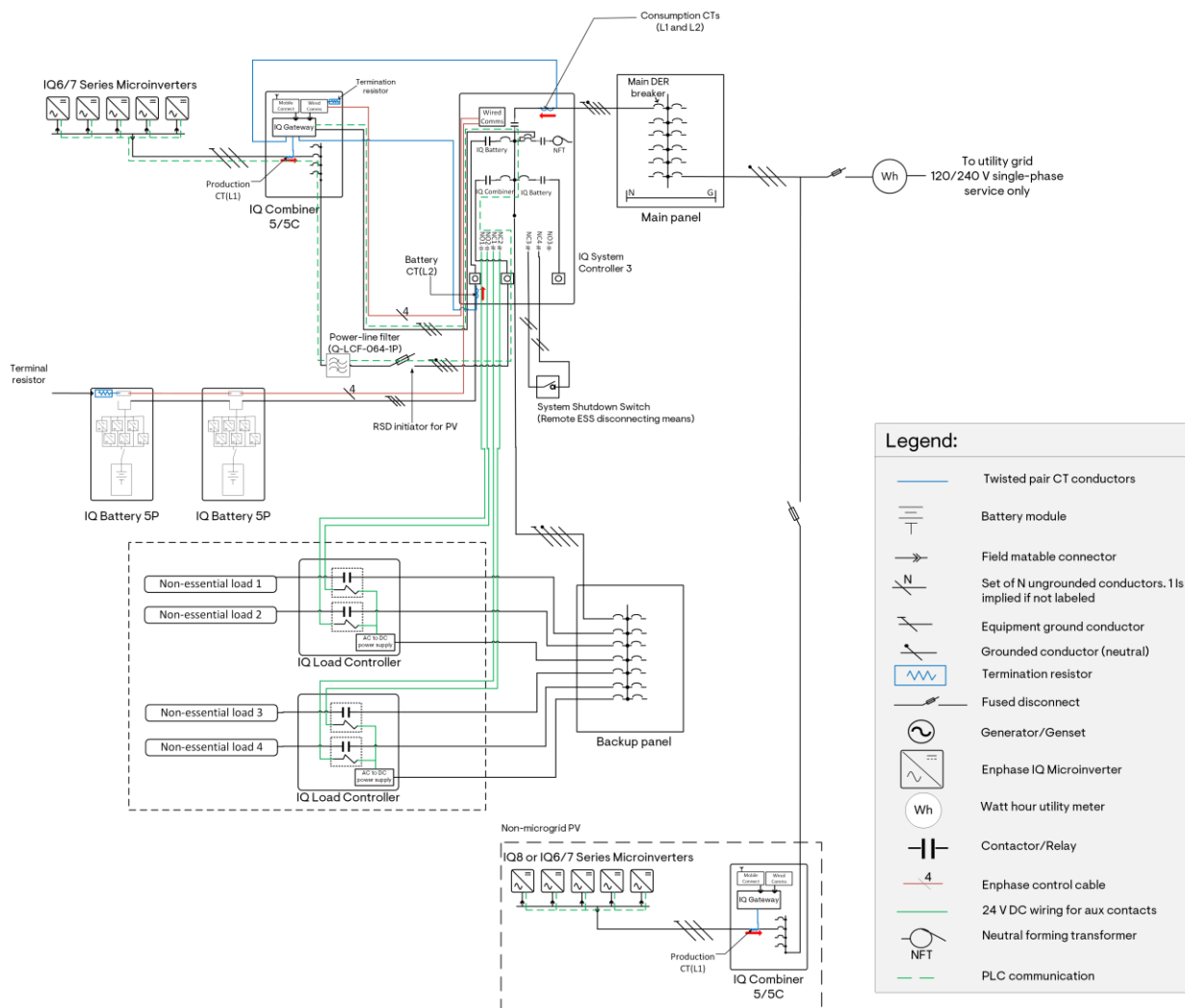

Figure 67: M Series “split” PV system without an additional set of Consumption CTs - Configuration to prevent the battery from discharging to serve loads on the main panel

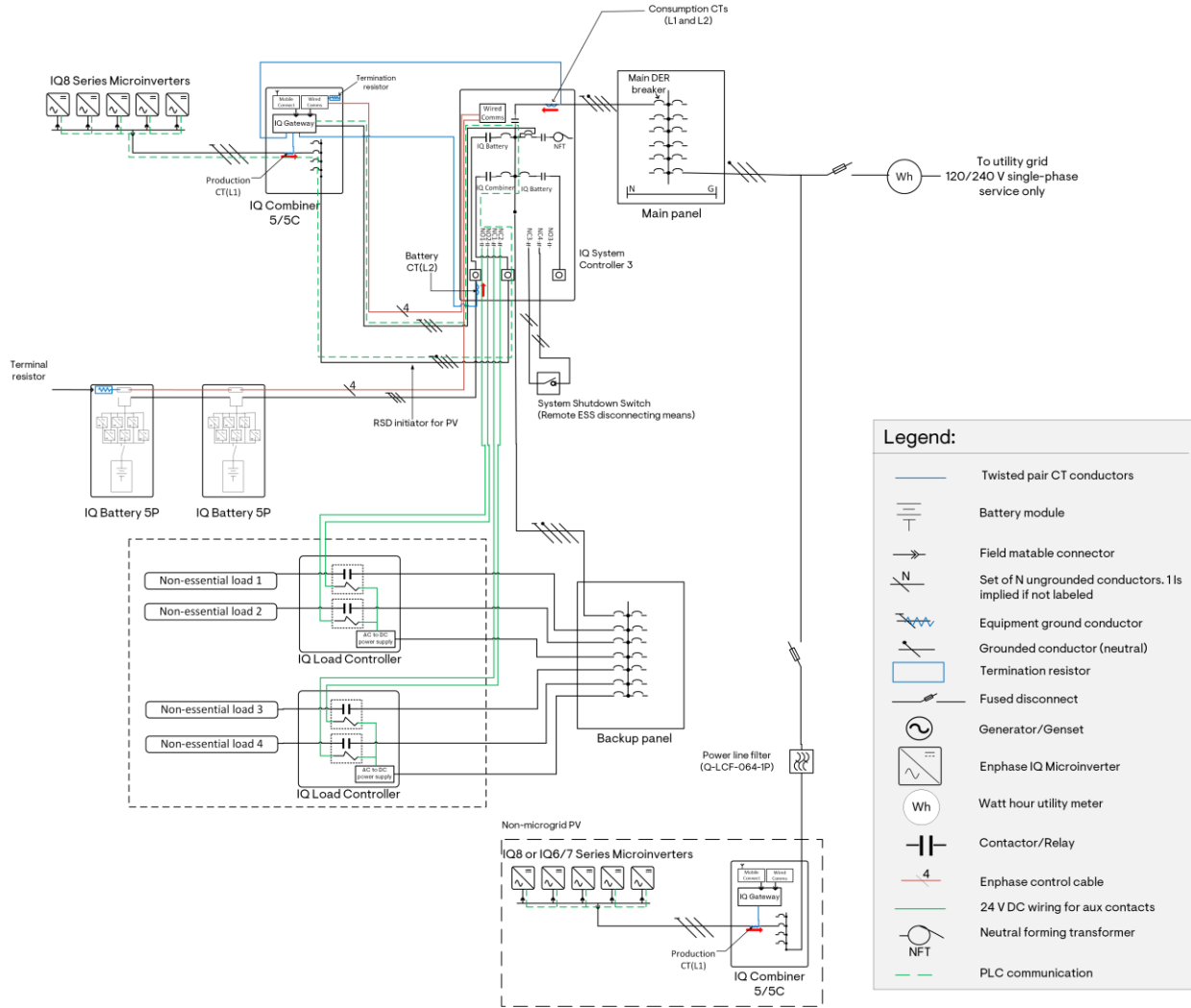
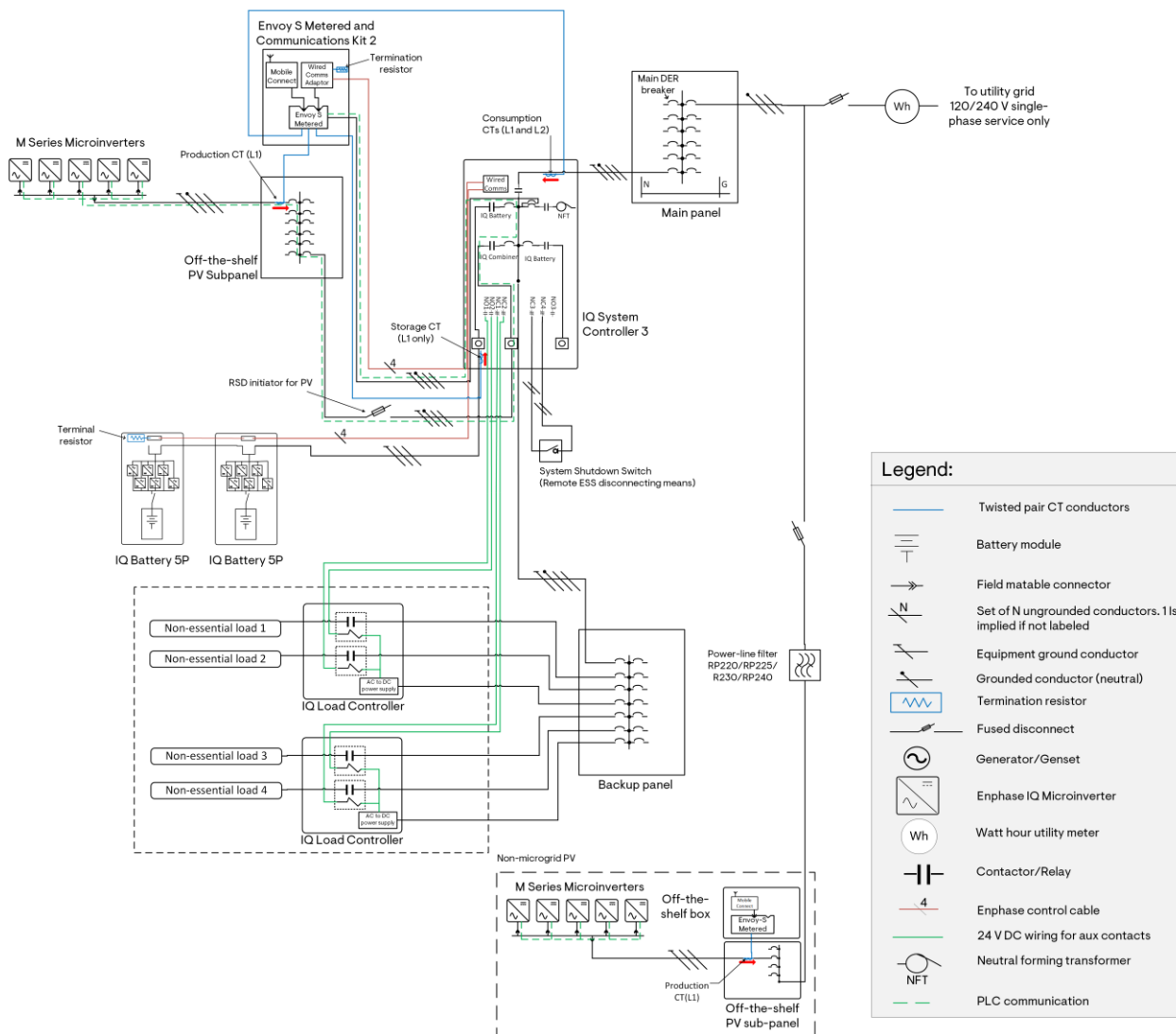

Figure 68: IQ8 Series “split” PV system without an additional set of Consumption CTs - Configuration to prevent the battery from discharging to serve loads on the main panel



Revision history

Revision	Date	Description
TEB-00004-3.0	August 2023	<ul style="list-style-type: none"> Added system configurations with IQ Battery 5P, IQ System Controller 3/3G, IQ Combiner 5/5C, and Communications Kit 2. Added grid-tied solar and grid-tied battery system configurations. Added generator sizing instructions. Added Appendix A “Other supported configurations”. Added Appendix B “Generator remote start wiring”. Removed section “Split Enphase Systems on a single site with IQ6/IQ7/IQ8 or M Series Microinverters” and added to Appendix C.

		<ul style="list-style-type: none"> Removed section “Physical Installation considerations”. Removed section “Enphase Energy System Products”. Added section “Control wiring”. Removed reference to Energy essentials and full energy independence; replaced with whole home backup and partial home backup, wherever applicable.
TEB-00004-2.0	April 2023	Editorial updates
TEB-00004-1.0	April 2023	Internal release
Previous release		

© 2023 Enphase Energy. All rights reserved. Enphase, the e and CC logos, IQ, and certain other marks listed at <https://enphase.com/trademark-usage-guidelines> are trademarks of Enphase Energy, Inc. in the US and other countries. Data is subject to change.