

BRIGGS&STRATTON®

SimpliPHI™ 6.6 Energy Storage System (ESS)

en Operator's Manual

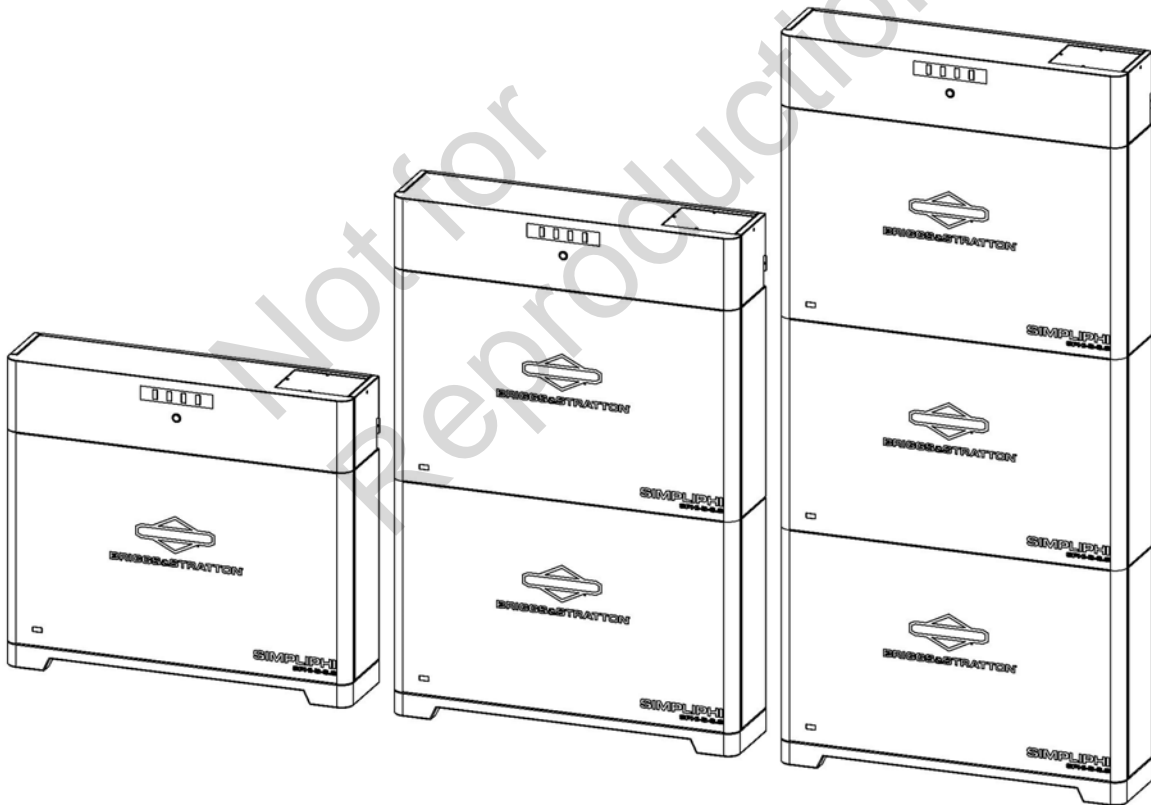

Table of Contents:

General Information	3
Thank You.....	3
General Information.....	3
Online Resources.....	3
Technical Support.....	3
Serviceability - No Internally Serviceable Parts.....	3
Glossary.....	3
Operator Safety	3
Safety Alert Symbol and Signal Words.....	3
Safety Warnings.....	4
Emergency Response Protocol.....	4
Product Information (Datasheet)	5
Pre-Installation	5
Installation Location.....	6
Installation Sizing.....	6
Converter and Load Requirements.....	7
Required Personal Protective Equipment (PPE).....	7
Required Tools.....	7
Required Components (Not Included).....	7
Required Components (Provided).....	7
Installation	7
Installation Options.....	8
Floor Mount Base Installation.....	8
Wall Mount Base Installation.....	9
Wall Bracket Installation.....	10
Battery and Controller Installation.....	12
Conduit Connection Sealing.....	14
Electrical Wiring Installation.....	15
Communication Wiring Installation.....	18
Completing Installation.....	20
Programming and Commissioning	21
EnergyTrak™ Programming and Commissioning.....	22
Third-Party Inverter or Controller Programming and Commissioning.....	22
Operation	22
Turn ON / OFF Battery Stack.....	22
Controller LED Indicator.....	22
Battery LED Indicator.....	22
Troubleshooting	22
Appendix	23

General Information

Thank You

Thank you for purchasing this quality-built SimpliPHI™ product. We are pleased that you have confidence in the SimpliPHI™ brand. When operated and maintained according to the manuals, this product will provide many years of dependable service.

The Operator's Manual contains safety information to make you aware of the hazards and risks associated with the unit and how to avoid them. This product was designed to be used as described in the Operator's Manual and is not intended for any other purpose. It is important that you read and thoroughly understand the instructions in the manual before attempting to start, operate, or service the product.

Save these original instructions for future reference.

This product requires final assembly, which is described in the Setup Instructions. Make sure to follow the instructions completely before use. If you need assistance with assembly, operation, or maintenance of the product, contact your local Authorized Service Dealer or visit energy.briggsandstratton.com.

General Information

Your product could look different from the images shown. *LEFT* and *RIGHT* are given from the operator's position.

All language translations of this document come from the English source file.

Recycle all cartons, boxes, and batteries as specified by government regulations.



Online Resources

The Product Documentation section of our website (Briggs & Stratton - Energy Storage) - includes Specification Sheets, Warranties, Installation & Operator's Manuals, and Integration Guides for all of Briggs & Stratton's current and legacy products.

Technical Support

ESS Technical Support (805-640-6700 x 1, ESSTech@basco.com) is available to take any questions regarding this manual or general installation questions. For assistance with battery system commissioning, Briggs & Stratton asks that a commissioning call be scheduled ahead of time with Technical Support.

We encourage you or your installer to contact ESS Tech Support with any questions. We are committed to working with you and your installation team to achieve a safe, reliable storage system that will provide years of maintenance-free service that is covered by our Warranty terms & conditions.

Serviceability - No Internally Serviceable Parts

The Controller, Battery Modules, Floor and Wall Bases do not have serviceable internal parts. There is no reason to ever open the units. If there are any issues with the system, contact ESS Technical Support (805-640-6700 x 1, ESSTech@basco.com). Our service team will make sure that your issue is resolved.

Any and all removable external paneling is replaceable. Please contact your sales representative for replacements.

Glossary

AC - Alternating Current

AHJ - Authorities Having Jurisdiction (e.g. local permitting body and utilities)

BESS - Battery Energy Storage System

BMS - Battery Management System

CAN - Controller Area Network

DC - Direct Current

Operator Safety

Safety Alert Symbol and Signal Words

The safety alert symbol  identifies safety information about hazards that can result in personal injury. A signal word (**DANGER**, **WARNING**, or **CAUTION**) is used with the alert symbol to indicate the likelihood and the potential severity of injury. Also, a hazard symbol can be used to show the type of hazard.

 **DANGER** indicates a hazard which, if not avoided, **will** result in death or serious injury.

 **WARNING** indicates a hazard which, if not avoided, **could** result in death or serious injury.

 **CAUTION** indicates a hazard which, if not avoided, **could** result in minor or moderate injury.

NOTICE Indicates information can be important but not hazard-related.

Safety Warnings

WARNING

Read all instructions and cautionary markings on the SimpliPHI Batteries, and all appropriate sections of this manual. Failure to follow the instructions provided in the Installation Manual, Integration Guides and/or Warranty could result in death or serious injury, will violate the terms of the Warranty, and may damage the batteries.

AVERTISSEMENT

Lire toutes les instructions et les avertissements sur les batteries SimpliPHI et toutes les sections appropriées de ce manuel. Ne pas suivre les instructions fournies dans le manuel d'installation, les guides d'intégration et/ou la garantie pourrait causer la mort ou des blessures graves, violera les modalités de la garantie et peut endommager les batteries.

WARNING

Loss of Life Hazard

Do not use this product to supply power to critical life support equipment. Inform your local utility company of the presence of critical life support equipment, to prioritize emergency service in the event of a power outage.

AVERTISSEMENT

Risque de perte de vie

Ne pas utiliser ce produit pour alimenter de l'équipement de maintien des fonctions vitales. Informer votre service public local qu'il y a équipement de maintien des fonctions vitales pour qu'on priorise le service d'urgence en cas de panne de courant.

WARNING

Unsafe Operation Hazard

Do not operate if the unit has been damaged in any way during shipping or on-site.

AVERTISSEMENT

Risque de fonctionnement non sécuritaire

Ne pas faire fonctionner l'appareil s'il a été endommagé de quelque façon que ce soit en cours d'expédition ou sur place.

WARNING

Shock Hazard

Before installation, make sure that:

- The existing system wiring is in good condition.
- The batteries are 'OFF'.
- The batteries are installed with the appropriate inverter and / or charge controller settings.

During installation, operation and maintenance:

- Remove watches, rings, or other metal objects.
- Wear proper Personal Protective Equipment (PPE), such as insulated gloves and rubber shoes.
- Use tools with insulated handles.
- Do not lay tools or metal parts on top of batteries.
- Do not combine different brands, chemistries or models of battery. (This will also void the Warranty.)

AVERTISSEMENT

Risque de choc électrique

Avant d'installer, s'assurer que :

- Le câblage existant du système est en bon état.
- Les batteries sont en position « ARRÊT ».
- Les batteries sont installées avec les paramètres appropriés d'onduleur et/ou de contrôleur de charge.

En cours d'installation, de fonctionnement et d'entretien :

- Enlever vos montres, bagues et autres objets métalliques.
- Porter l'équipement de protection individuelle (EPI) approprié, p. ex., gants isolants et chaussures de caoutchouc.
- Utiliser des outils dont les poignées sont isolées.
- Ne pas placer d'outils ou de pièces métalliques sur les batteries.
- Ne pas combiner marques, chimies ou modèles différents de batteries. (La garantie sera annulée ainsi.)

Emergency Response Protocol

In the unlikely event SimpliPHI batteries are involved in or near a fire (e.g. electrical fire), the primary concern is personal safety. The area should be immediately evacuated, and all personnel accounted for. Emergency response organizations, either internal or external, should be immediately notified. In the event of an emergency, call 911. In the event of a system malfunction, call 805-640-6700 x 1.

The following protocol should be administered to decommission the system after eliminating any fire risk:

- Make sure that the system is no longer energized, either from the solar array or the grid (main disconnect). Turn OFF all breakers and connected components that are safely accessible.
- Separate any external cables from batteries if present (cut if necessary) using insulated tools.
- Wear a respirator or dust mask to avoid inhaling soot/dust.

- Wear insulating and abrasion-resistant gloves (if permeable, over nitrile or similar gloves).
- Move battery debris into non-conductive bins capable of handling the weight.
- Dispose as local regulations require.

Water is an acceptable and effective extinguishing agent for the SimpliPHI 6.6 BESS. The Balance of System equipment used in conjunction with the SimpliPHI Batteries may require specialized extinguishers such as FM-200 or CO2 suppression systems.

Product Information (Datasheet)

Battery Specifications (LFP)	
Stack Information	
Maximum per Stack	3
Maximum per System	18
Full Stack Dimensions	H: 60.4" x W: 28.6" x D: 6.7"
Voltage (per Battery)	
DC Voltage – Nominal	51.2 VDC
DC Voltage Range	44.8 - 56.8 VDC
Current (per Battery)	
Continuous Discharge Current - Maximum	130 ADC
Continuous Charge Current - Maximum	100 ADC
Maximum Charge Surge Currents and Durations (ADC, sec)	110A, 10 sec; 125A, 2 sec
Maximum discharge Surge Currents and Durations (ADC, sec)	240 ADC, 2 sec; 300 ADC, 1 sec
Capacity	
Rated Capacity (Amp-Hours) - Nominal	130
Rated Capacity (Wh) - Nominal	6656
Operational Electrical Specifications	
Self-Discharge Rate (shutdown/off)	<.03 %/month
Cycle Life at 100% Depth-of-Discharge	4500 Cycles @ 0.75C charge/discharge rate (6000 cycles @ 80% DoD)
End of Life Capacity	75%
Minimum Round-Trip Efficiency Rating (C/2)	≥96%
Operational Environment	
Charge Temperature	-10°C ~ 50°C
Discharge Temperature	-20°C ~ 55°C
Operating Humidity	0% - 95% RH
Storage Environment	
Storage Temperature	-20°C ~ 55°C for 1 month; -20°C ~ 45°C for 6 months
Storage Humidity	0% - 95% RH
Physical Dimensions and Ratings (per Battery)	
Enclosure Material	Powder-coated Steel
Width - Inches (mm)	28.6" (725.0)
Depth - Inches (mm)	6.7" (170.0)

Height without Tabs - Inches (mm)	17.3" (440.0)
Height with Tabs Inches (mm)	18.9" (479.2)
Weight (kg)	140 lbs (63.3)
IP Rating	IP 20 (IP 65 when installed)
Altitude	≤3000m
Corrosion resistance rating	240H
Certifications	UL9540, UL1973, UL 1998 + 991, UN 38.3, UN 3480, IEC62619, UL 9540A Fire Safety Tested
Communication	
CAN, RS485	Compatible with Sol-Ark, Briggs & Stratton

Controller Specification		
Stack Information		
Controllers per Stack (up to 3 batteries)	1 required	
Maximum Controllers per System	6	
Voltage		
DC Voltage Rating	44.8 ~ 56.8 VDC	
Current		
Current Rating - Continuous Maximum	273 ADC	
Operational Environment		
	Operating Temperature	-10°C ~ 55°C
	Operating Humidity	0% - 95% RH
Storage Environment		
	Storage Temperature	-20°C ~ 55°C
	Storage Humidity	0% - 95% RH
Physical Dimensions and Ratings		
	Width (mm)	28.6" (725.0)
	Depth (mm)	6.7" (170.0)
	Height (mm)	6" (150.0)
	Weight (kg)	14 lbs (7.0)
	IP Rating	IP 65
	Altitude	≤3000M
	Corrosion resistance rating	240H
	Enclosure Material	Powder-coated Steel
Communication		
	CAN, RS485	Compatible with Sol-Ark, Briggs & Stratton
Floor Mount Specification		
	per Stack (up to 3 batteries)	1
	Width (mm)	28.6" (725.0)
	Depth (mm)	6.7" (170.0)
	Height Tabs (mm)	3.7" (95.0)
	Height without Tabs (mm)	2.5"
	Weight (kg)	5 lbs (2.3)

Pre-Installation

Installation Location



WARNING **Fire Hazard**

The SimpliPHI 6.6 Battery System must be installed on a non-flammable surface. If installed on flammable construction, a non-flammable material must be placed between the system and the flammable surface. If there are any concerns, contact your local AHJ.

AVERTISSEMENT **Risque d'incendie**

Le système de batteries SimpliPHI 6.6 doit être installé sur une surface non inflammable. S'il est installé sur une construction inflammable, un matériel non inflammable doit être disposé entre le système et la surface inflammable. En cas de préoccupation, contacter votre autorité compétente locale.

Install the SimpliPHI battery system in a location with the following requirements:

- Ambient temperature: 14°F - 122°F (-10°C ~ 50°C)
- Relative Humidity: 5 – 95% non-condensing
- At least 3 feet from explosive or flammable objects
- On a concrete structure or floor
- More than a half mile from the ocean/sea and protected from saltwater spray
- Protected from corrosive chemicals
- Indoor residential installations must be provided with smoke alarms in accordance with building and fire codes

Detail Notes:

This product is suitable for use in Residential Non-Habitable spaces. Consult your local AHJ for approved locations under code.

Ambient Temperature: The SimpliPHI Battery's BMS and protective circuitry prevent it from charging below 14°F (-10°C) or above 122°F (50°C). Additionally, when connected over CAN to an approved inverter or gateway, the charge and discharge rates will automatically curtail when internal battery temperature goes beyond the recommended values. For optimal battery performance, install in an area where ambient temperature does not drop below freezing, 32°F (0°C), or go above 104°F (40°C). In controlled environments, a room temperature of 70-75°F (22-24°C) is optimal.

Relative Humidity: Most electronics, including Lithium-Ion battery systems, are not safe to operate if there is condensation or water accumulation on or around the power terminals. Make sure all exposed (non-painted) metal components are dry before powering on the system.

On a concrete structure or floor: The SimpliPHI 6.6 battery system is certified for use in stationary applications. With the weight of a stack of batteries being between 150 and 435 lbs, the system must be securely fastened to a solid floor or concrete structure rated for the weight load.

At least three (3) feet from explosive or flammable objects: SimpliPHI Batteries are not ignition protected. To prevent fire or explosion, do not install this product in locations that require ignition-protected equipment. This includes any confined space containing different vented batteries or flammable chemicals such as natural gas (NG), liquid petroleum gas (LPG) or gasoline (Benzine/Petrol). Do not install in a confined space with machinery powered by flammable chemicals, or storage tanks, fittings, or other connections between components of fuel or flammable chemical systems.

More than a half mile from the ocean/sea and protected from saltwater spray: This unit is not intended for installation near marine environments or at locations with salt fog. Batteries should not be installed in locations in which they are exposed to saltwater spray. It is highly recommended to install the system in a location that isn't directly exposed to sea breeze. If in an area with a sea breeze, make sure the sea breeze is blocked by a building. Damage caused by outdoor installation in salt-affected areas is not covered by the warranty. A salt-affected area refers to the region within a half mile from the coast and in areas directly affected by scattered seawater or prone to sea breeze.

Protected from corrosive chemicals: Anticorrosive compounds or epoxies are occasionally used in harsh or marine climate installations. SimpliPHI Batteries are powder-coated steel and may exhibit discoloration when exposed to extreme elements and harsh chemicals. This discoloration will not affect battery performance but is not covered under Warranty. Batteries should not be installed in locations in which they are exposed to chemicals that may cause discoloration.

The ESS shall only be installed in the following locations:

1. In attached garages separated from the dwelling unit living area and sleeping units in accordance with the local building code
2. In detached garages and detach accessory structures
3. Outdoors on exterior walls or on the ground located a minimum of 3 ft (914 mm) from doors and windows directly entering the dwelling unit
4. In enclosed utility closets and storage or utility spaces where approved by the AHJ

The ESS is NOT intended for installation in habitable spaces and living spaces in dwelling units. The ESS is intended for installation in non habitable spaces such as detached garages, sheds, enclosed utility closets, basements, storage or utility spaces.

Installation Sizing

The SimpliPHI 6.6 battery and system is designed to operate at ≤56.8 VDC. Do not connect the batteries or stacks in series; only parallel connections are supported. Each battery has a continuous charge and discharge rate of 100 and 130 ADC, respectively (maximum 273A per stack). The maximum short circuit current is 2000A for 100 milliseconds. Make sure that the loads, charger, and any other component connected to the SimpliPHI 6.6 do not exceed these specifications.

CAUTION

A SimpliPHI 6.6 Battery System cannot exceed 6 Controllers OR 18 battery modules per bank. Sizing SimpliPHI 6.6 Battery Systems larger than 6 Controllers OR 18 battery modules may cause damage to the SimpliPHI 6.6 batteries and will violate the terms of the Warranty.

ATTENTION

Un système de batteries SimpliPHI 6.6 ne doit pas compter plus de 6 contrôleurs OU 18 modules de batteries par banc. Les systèmes de batterie SimpliPHI 6.6 de plus de 6 contrôleurs OU de 18 modules de batteries peuvent endommager les batteries SimpliPHI 6.6 et annuleront les modalités de la garantie.

Converter and Load Requirements

The SimpliPHI 6.6 BESS is intended for use with a DC source-load (e.g. hybrid inverter or charge controller) that operates within 45-58 VDC. The recommended maximum load is <130A for each SimpliPHI 6.6 Battery in the system.

Required Personal Protective Equipment (PPE)

Insulated Safety Gloves
Safety Goggles
Rubber Safety Shoes

Required Tools

#1 & #2 Screwdrivers	Torque Socket Wrench	Drill / Hammer Drill	Level
Wire Strippers	Cable Cutter	Crimping Tool	Hydraulic Punch or Metal Hole Saw
Utility Knife	Measuring Tape	Pencil	Multimeter (voltage measurement range 0-60 VDC)
Heat Gun	Torx T20 Screwdriver	RJ45 Crimper and Terminals	Hammer

Required Components (Not Included)

Positive Cable (generally RED 4/0AWG, follow NEC and AHJ requirements)	Negative Cable (generally BLACK 4/0AWG, follow NEC and AHJ requirements)	3/8" closed-end Power Lugs - Quantity 2	
Heatshrink (required for installations in humid and coastal areas)	Metal Shims		

Floor Fasteners Concrete: 1/4"-5/16" diameter, >2" length Wood: wood screws, 1/4"-5/16", length to full thread engagement through the subfloor	Wall Anchors Wood Studs: lag screws, 1/4"-5/16" diameter, 1 1/4" stud penetration depth Metal Studs: toggle bolts, 1/4"-5/16" diameter Concrete: Anchors, 1/4"-5/16" diameter, >1" length
---	--

Required Components (Provided)

Floor Mount Base Components (per box)	
Name	Quantity
Floor Mount Base	1

Wall Mount Base Components (per box)	
Name	Quantity
Wall Mount Base	1

Controller Components (per box)	
Name	Quantity
Controller	1
Screw, M4 x 10mm	2
Grounding Screw, M5 x 10mm	1
Terminal Screw, M10 x 30mm	2
Copper Washer (for double lugging only)	2
RJ45 Battery CAN Terminator	1

Battery Components (per box)	
Name	Quantity
Battery Module	1
Battery Side Panel	2
Screw, M4 x 10mm	2
Wall Bracket Vertical Spacer	1
Wall Bracket Horizontal Retainer	1

Installation

WARNING

SimpliPHI Batteries must be installed, wired and commissioned by a qualified installer or professional electrician who is familiar with general electrical safety precautions and specific regional code requirements.

AVERTISSEMENT

Les batteries SimpliPHI doivent être installées, câblées et mises en service par un installateur qualifié ou un électricien professionnel qui connaît les précautions de sécurité électrique générales et les exigences du code régional spécifiques.

SimpliPHI battery systems must be installed per the latest NEC, NFPA 855, and local AHJ codes, standards and regulations. Consult your local AHJ for specific variances that apply to local code and may not be reflected in this document.

For residential applications, under NFPA 855, installations must adhere to three feet of spacing between units unless otherwise approved by your local AHJ.

Installation Options

The SimpliPHI 6.6 Batteries are designed to be floor or wall mounted in a stack of 1, 2, or 3 batteries. See Figure 1.

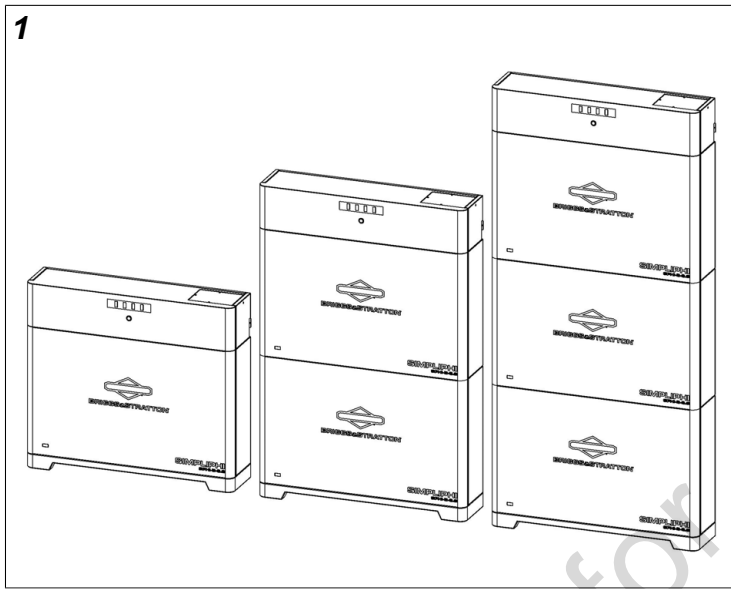

A maximum of 6 stacks can be connected in a single system. Per NFPA 855, a maximum of 40kWh or 80kWh or 4 stacks can be installed in a single residential location as follows:

Location	Maximum Capacity
Utility closets, basements, storage or utility spaces	40 kWh
Attached or detached garages and detached accessory units	80 kWh
Outdoor Wall Mounted	80 kWh
Outdoor Ground Mounted	80 kWh

For systems larger than 80 kWh, consult your local AHJ for site specific requirements on systems installed in residential or non-residential applications.

Each stack must have a Briggs & Stratton controller at the top and a Briggs & Stratton floor or wall mount bracket base on the bottom. Each stack must be installed at least 3 feet away from each other.

The installed wall hardware must be attached to concrete or finished studs. Drywall anchors can be used in addition to, but cannot replace, the structural hardware.

Installation Angle

The SimpliPHI 6.6 battery is designed to be vertically mounted. The battery system must be installed upright with less than 1° tilt from vertical. Do not install the battery system upside down, on its back, side, more than 1° tilt from vertical,

or on tilted walls. When installing the SimpliPHI 6.6 battery on uneven or sloped surfaces, it might be necessary to install shims between the floor and the bottom of the foot.

Floor Mount Base Installation

(ordered separately)

If installing using a wall mount, skip to *Wall Mount Base Installation*.

Product is intended for installation in non-seismic zones only.

For non-seismic zone floor mount installations, install on concrete floors with anchors using 1/4"-5/16" fasteners to >2" deep or wood floors with 1/4"-5/16" lag screws to full thread engagement through the subfloor.

Preparation: Use a level to determine if the floor is level and that the wall is plumb. If the floor is not level, shims can be used to create a level surface.

1. Use a measuring tape to determine the hole positions for the floor mount base according to Figure 2 below. Mark the positions using a marker or pencil.

NOTE: Use the provided positioning guide to determine the spacing from the wall to the floor mount base. The back holes of the floor mount base must be ~1 5/8" from the wall, not including the baseboard or trim.

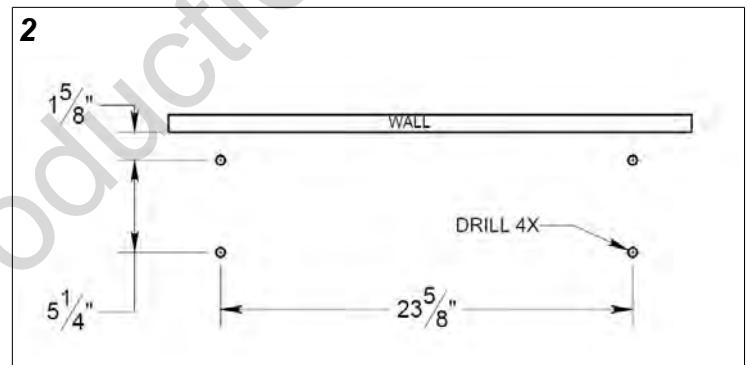

2. Pre-drill holes as required for fasteners to be used. For concrete, use of a hammer drill is recommended.
3. Remove any dust from in and around the holes and verify the distances between anchor points after drilling. If the holes are incorrectly positioned, mark and drill again leaving enough space to not interfere with the existing holes.
4. If required, follow the manufacturer's instructions when placing anchors.

- Place the floor mount base on the floor aligned with the holes. Hand tighten the 4 bolts with appropriate locking and flat washers. See Figure 3. Make sure that the floor mount base is level. Adjust with shims if necessary.

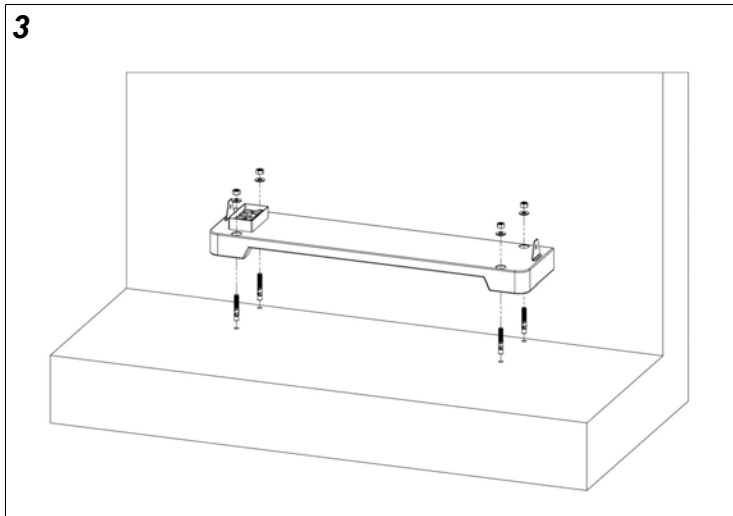

- Tighten the bolts to manufacturer torque specifications. Do a second check to make sure that the floor mount base is still level.

Floor Mount Base Installation is complete. Move on to Wall Bracket Installation.

Wall Mount Base Installation (ordered separately)

The SimpliPHI 6.6 Battery wall mount base is designed to secure up to three (3) SimpliPHI 6.6 Batteries to a load bearing surface. The wall mount base can be mounted directly to a wall, or it can be arranged on strut channels for ease of positioning (fastening hardware is not included). The wall mount base must be mounted into two (2) load bearing beams, studs, or a solid material, with appropriate fasteners. The wall mount base is designed to hold up to three SimpliPHI 6.6 Modules and one Controller with a combined weight of up to 435 pounds.

WARNING

A qualified installer familiar with the appropriate load bearing requirements must install a wall mounted system. Briggs & Stratton is not liable for damage caused by the inappropriate installation of the system.

AVERTISSEMENT

Un installateur qualifié qui connaît les exigences de charge appropriées doit installer un système mural. Briggs & Stratton n'est pas responsable des dommages que cause une installation inappropriée du système.

WARNING

Do not anchor to drywall alone. The system must be anchored to wood studs, cement blocks or concrete.

AVERTISSEMENT

Ne pas ancrer à une cloison sèche seulement. Le système doit être ancré à des clous de bois, à des blocs de ciment ou au béton.

WARNING

Check with the local AHJ regarding required mounting height above the floor.

AVERTISSEMENT

Consulter l'autorité compétente locale quant à la hauteur de montage requise au-dessus du plancher.

WARNING

When the battery is installed on the wall, do not place any objects below or on top of the battery.

AVERTISSEMENT

Quand la batterie est installée au mur, ne pas disposer d'objets en dessous ou au-dessus de la batterie.

Preparation: Identify and mark the locations of any electrical, plumbing, etc., to be avoided.

For Attachment to Studs: Use a stud finder or similar tool to locate the studs or other load-bearing structures within the walls and mark the locations.

1. **For Stud attachment:** Following Figure 4 below, use a measuring tape to determine the hole positions for the wall mount base and mark the positions using a marker or pencil. Space the holes according to the stud spacing and put 2 bolts/lags per stud for a total of 4 bolts/lags in 2 studs.

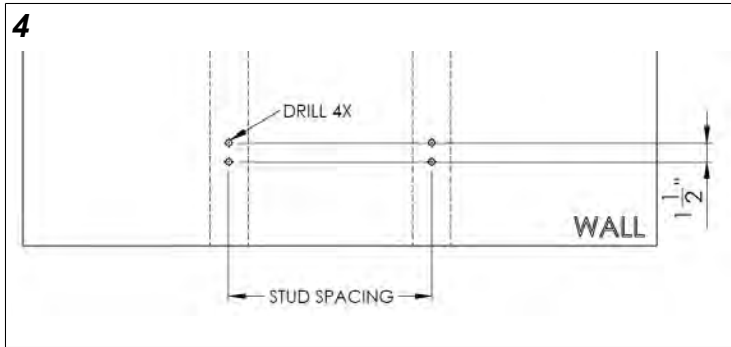

For Concrete Wall attachment: Use all 12 holes specified in Figure 5.

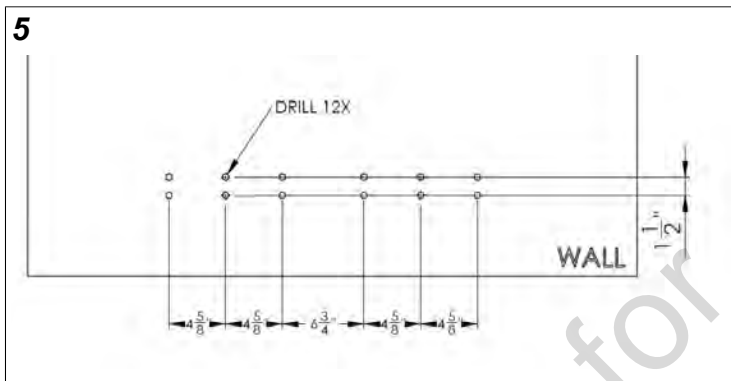

2. As required by the fastener manufacturer's recommendations, use the appropriate drill for the material to pre-drill holes on the wall in the specified positions.

Recommended fasteners:

 - **Wood Studs:** lag screws of 1/4"-5/16" diameter and >3" length.
 - **Metal Studs:** 1/4"-5/16" bolt diameter toggle bolts
 - **Concrete:** Anchors with 1/4"-5/16" bolt diameter and >1" insertion into concrete.
3. Remove any dust from in and around the holes and measure the hole distances after drilling. If the holes are incorrectly positioned, mark and drill again. Leave enough space to not interfere with the existing holes.
4. As specified by the fastener manufacturer, insert the anchors into the holes
5. Place the wall mount base on the wall aligned with the holes. Tighten the bolts by hand, with appropriate lock washers and fender washers. See Figures 6 (for studs) or 7 (for concrete). Make sure that the wall mount base is level. Adjust if necessary.

6. Tighten the bolts to manufacturer's torque specifications. Then do a second check to make sure that the wall mount base is level.

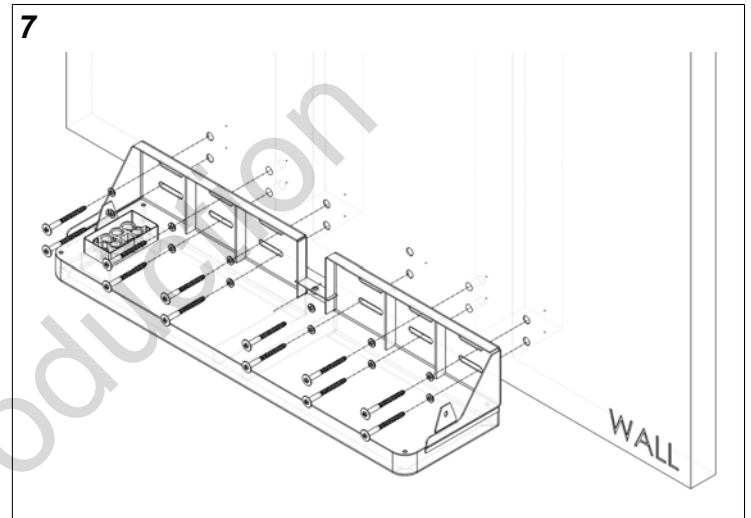
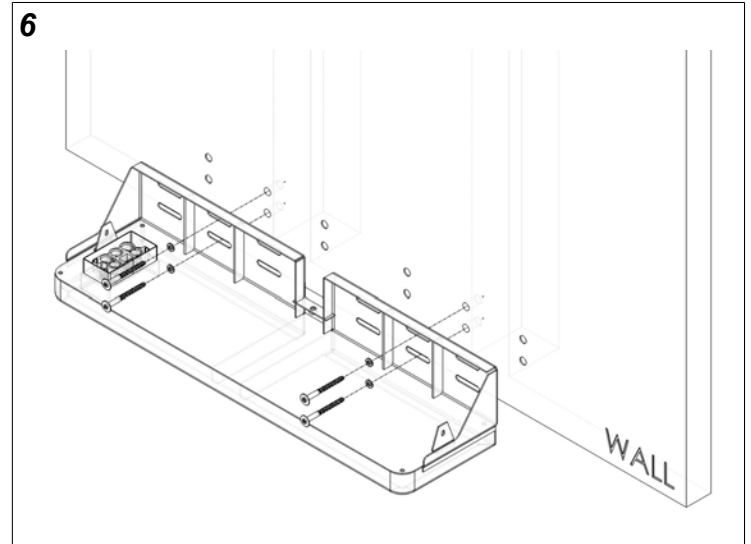

Wall Mount Base installation is complete. Move on to Wall Bracket Installation.

Wall Bracket Installation

For floor mount installations:

Preparation: Measure the centerline of the floor mount base (14 1/4" from the edge) and mark the center line on the floor mount base.

1. Align the bottom of the Vertical Spacer with the line drawn in the steps above. Fasten the Vertical Spacer, as shown in Figure 8, so it does not move.

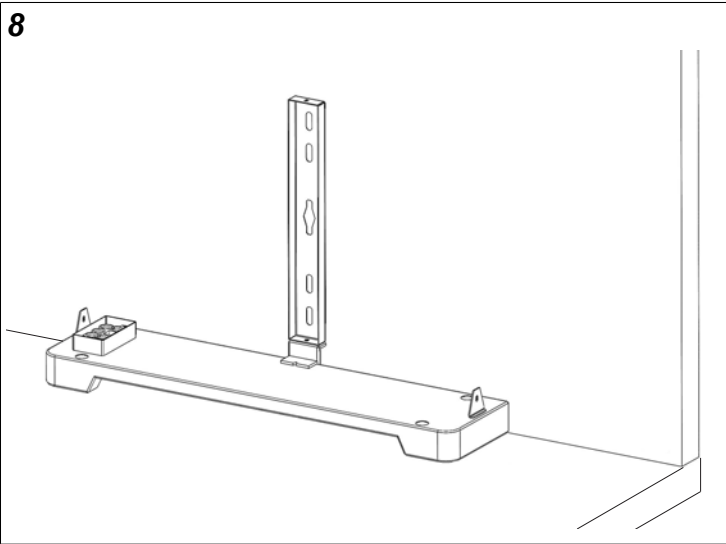

For wall mount installations:

1. Using the provided M6 x 5/16" screw, attach the Vertical Spacer to the Wall Mount Base as shown in Figure 9.

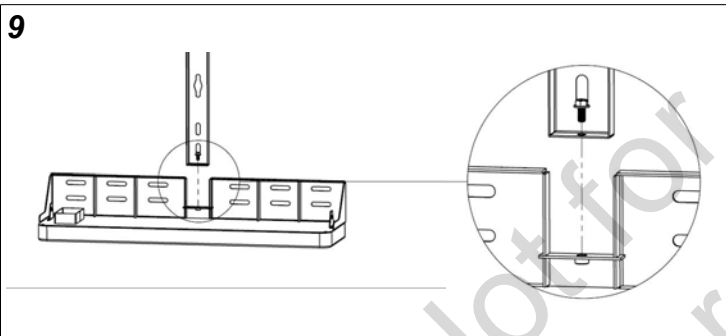

For all installations:

1. Using the provided M6 x 5/16" screw, attach the Horizontal bracket to the Vertical Spacer as shown in Figure 10.

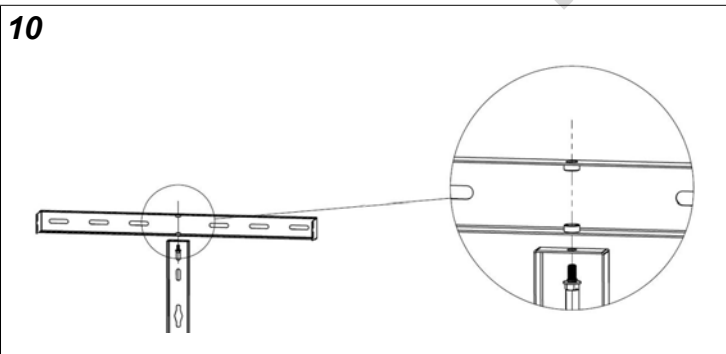

2. Check that the Horizontal Retainer is level. Mark the locations on the wall where bolts for the Horizontal Retainer will be installed as shown in Figure 11 (for studs) or 12 (for concrete).

3. Attach the Horizontal Retainer to the wall using appropriate hardware for the wall material. Use appropriate fender washers as well.

Recommended Fasteners

Wood Studs: 1/4"-5/16" diameter wood screws, 2" or longer

Metal Studs: 1/4"-5/16" diameter toggle bolts.

Concrete: 1/4"-5/16" diameter bolts in anchors installed at least 1" into concrete.

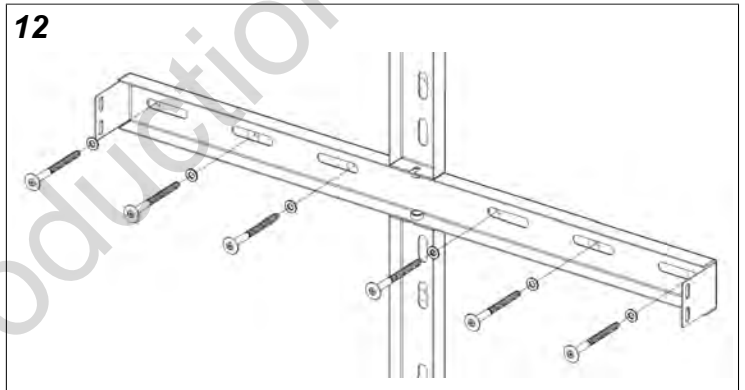
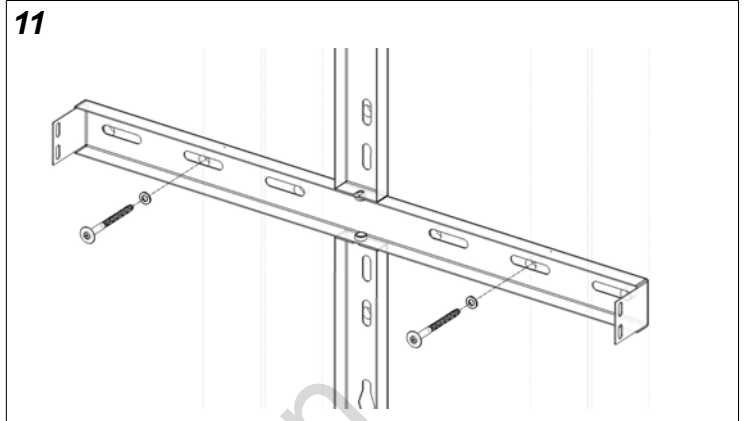

4. For each additional battery (up to three) in the stack, screw in the vertical spacer to the last horizontal retainer installed. Repeat steps 1 through 3 for each horizontal retainer, as shown in Figure 13 (for studs) or 14 (for concrete).

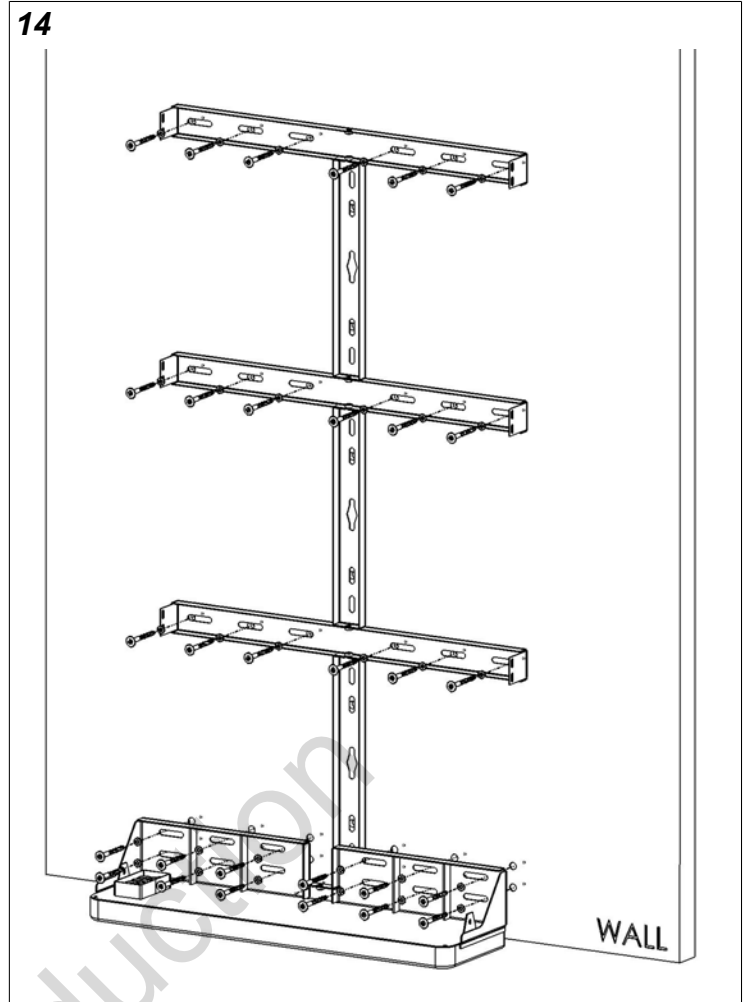
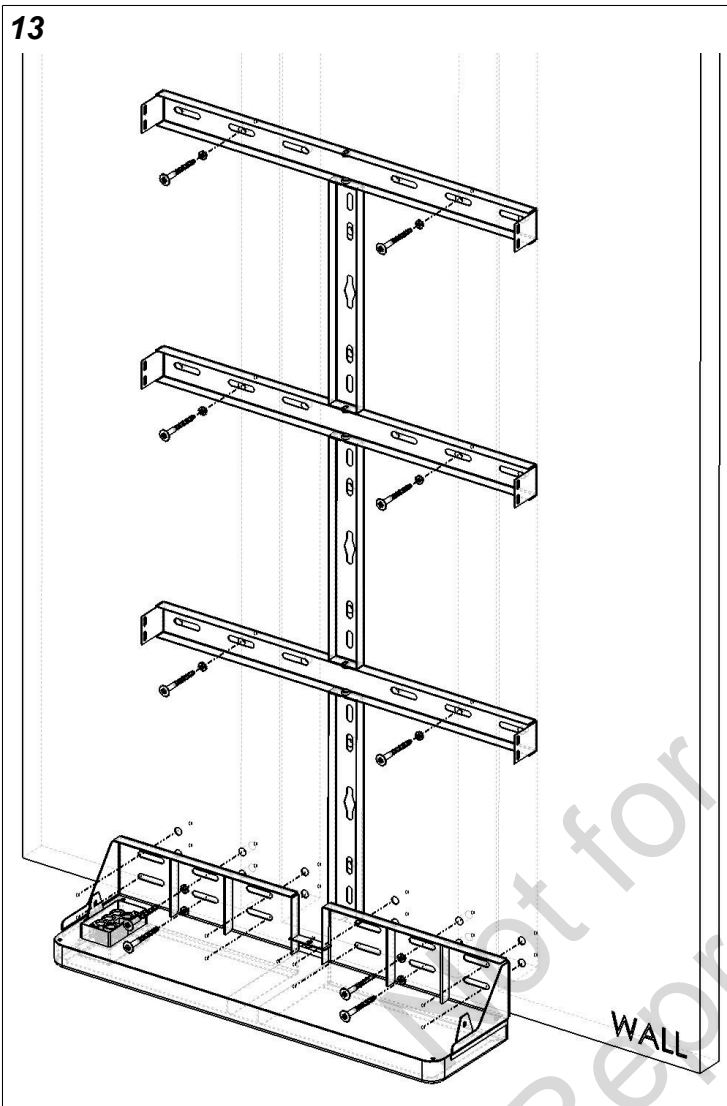

Wall Bracket Installation complete. Move on to *Battery and Controller Installation.*

Battery and Controller Installation

WARNING

Each SimpliPHI 6.6 battery weighs 140 lb. Have at least two (2) people lift the battery. Follow proper lifting form to minimize the chance of injury.

AVERTISSEMENT

Chaque batterie SimpliPHI 6.6 pèse 140 lb. Deux (2) personnes au moins doivent soulever la batterie. Suivez les consignes de soulèvement appropriées pour minimiser les risques de blessure.

1. Remove the four rear shoulder screws as shown in Figure 15.

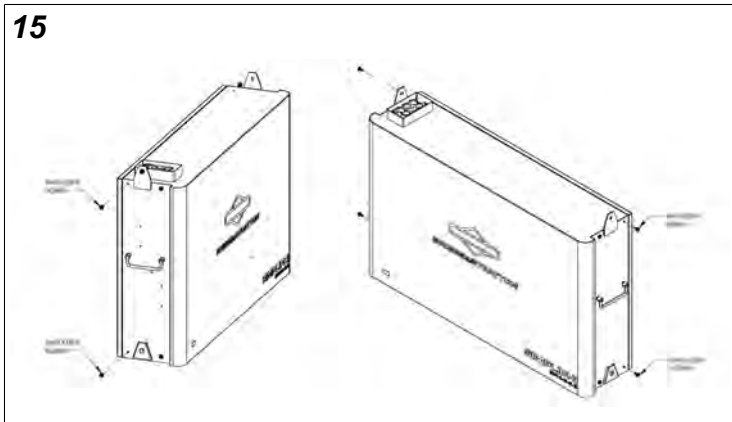

2. Install the first battery module on the base by aligning the bracket guides on the side of the battery with the tabs on the battery mount. Attach the battery module to the mount using the provided M4 x 10mm screws. See Figures 16 and 17.

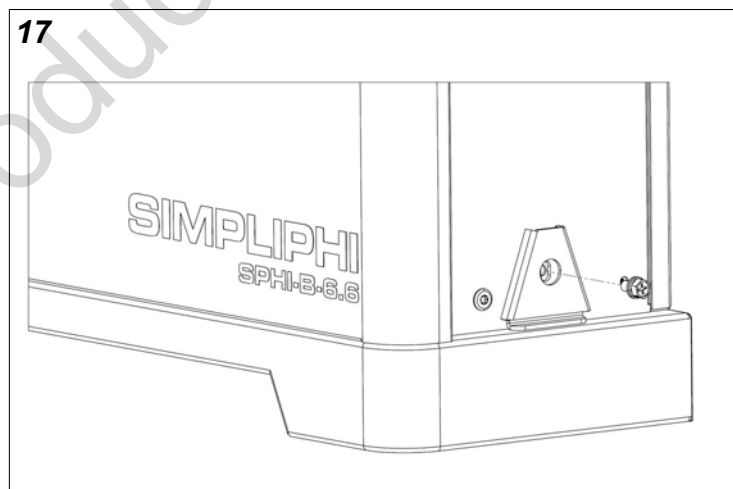
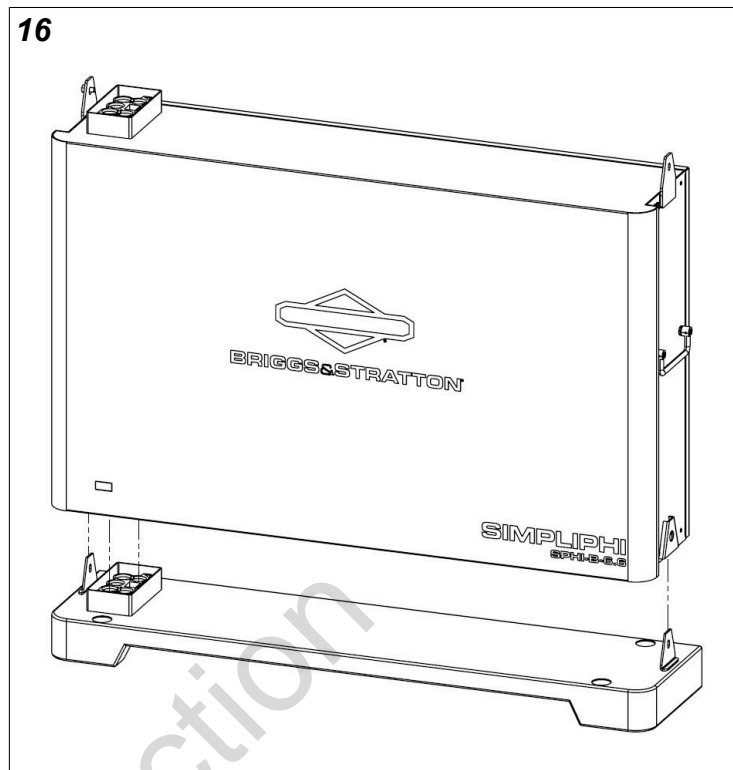

Not for
Reproduction

- Reinstall the rear shoulder screws into the battery through the slot on the wall retainer, as shown in Figure 18.

18

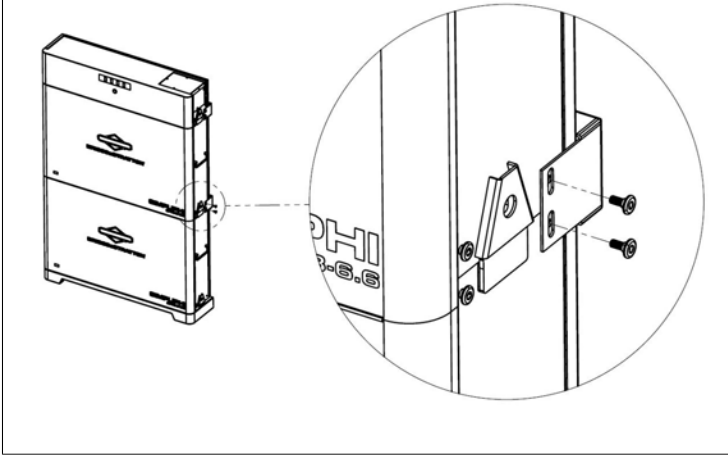

- If applicable, repeat steps 1-3 to install the second battery module on top of the first and the third battery on top of the second. See Figure 19.

19

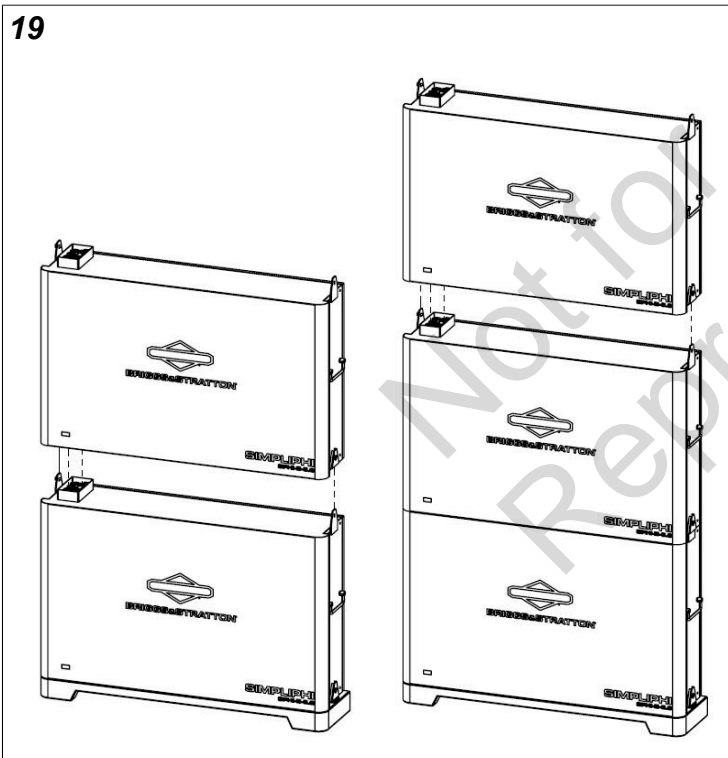

- Once all batteries are stacked and properly attached to each other, install the controller on top of the last battery by aligning the bracket guides on the side of the Controller with the tabs on the battery. Attach the controller to the battery using the provided M4 x 10mm screws. See Figure 20.

20

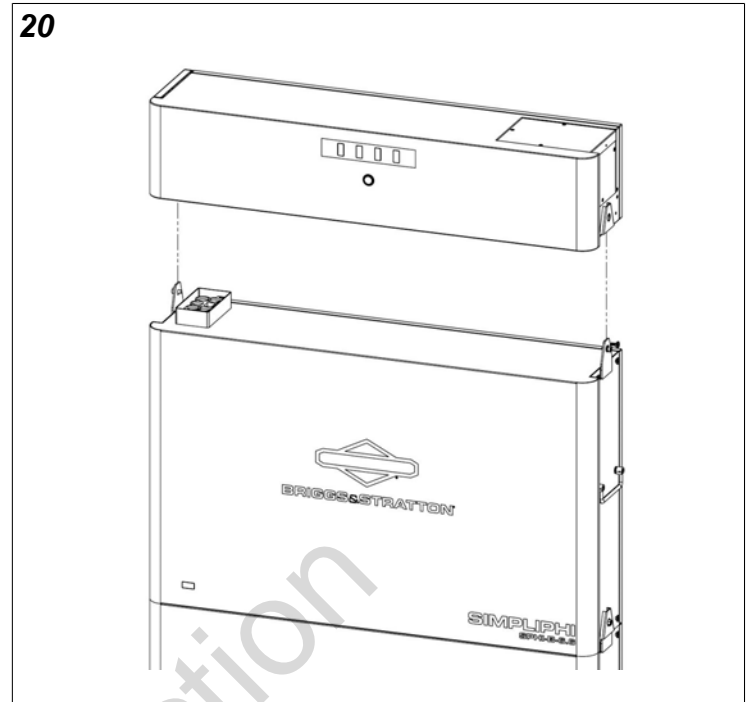

This completes installation of the SimpliPHI 6.6 BESS. Continue to Conduit Connection Sealing (outdoors) or Electrical Wiring Installation (indoors).

Conduit Connection Sealing

If the local AHJ or NEC requires a sealed conduit to be installed:

- Use a #1 Phillips screwdriver to remove the six (6) M3 x 8mm screws from the top plate and four (4) M3 x 8mm screws for the side plate from surrounding the electrical compartment of the Controller. See Figure 21.

21

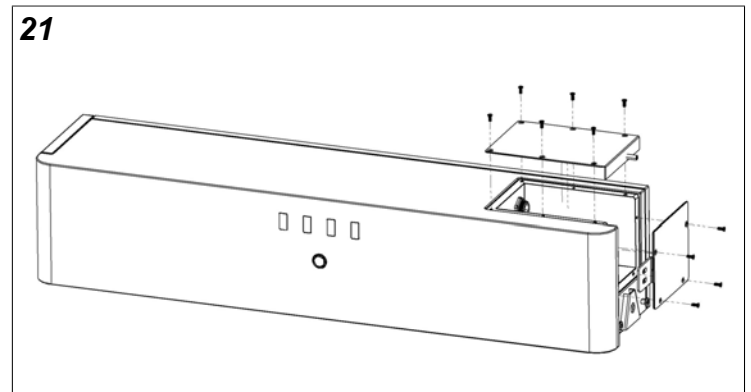

- Choose the appropriately sized conduit, up to 2" trade size maximum, for your cables per local AHJ and NEC installation requirements.

3. Mark and punch the conduit entry point in the side plate. See Figure 22.

NOTE: Using the top plate for conduit or wiring accessibility will void the IP65 outdoor rating.

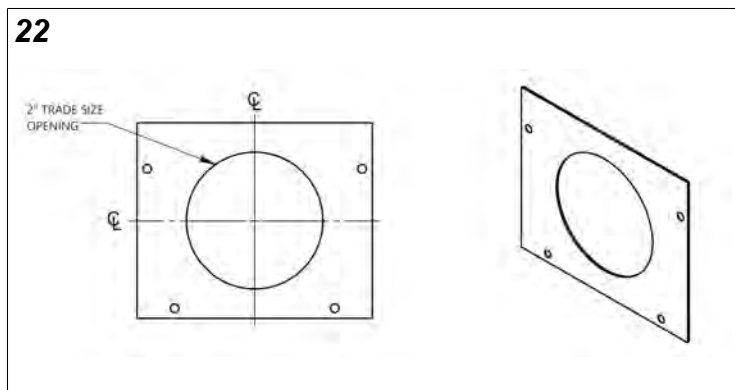

4. Install the conduit chase nipple or appropriate outdoor rated fitting onto the side plate. See Figure 23.

NOTE: Using the top plate for conduit or wiring accessibility will void the IP65 outdoor rating.

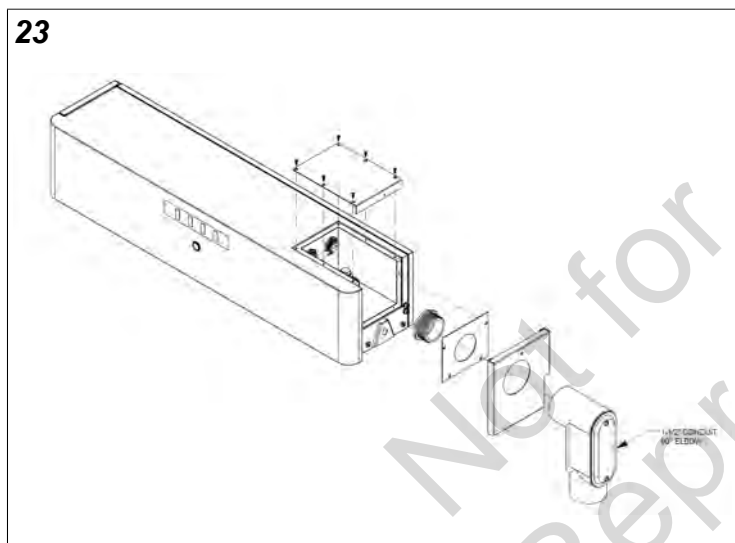

5. Reinstall the side plate using the four (4) M3 x 8mm screws and a #1 Phillips screwdriver. **DO NOT INSTALL THE TOP PLATE YET.**

This completes installation of the Conduit. Move on to Electrical Wiring Installation.

Electrical Wiring Installation

CAUTION

Do not tighten the terminals beyond their maximum torque value of 15 ft-lbs (180 in-lbs). Use of an impact driver or power tools on the terminals will violate the terms of the Warranty. Use of power tools or impact drivers may cause damage to the terminal even if it does not result in breakage.

ATTENTION

Ne pas serrer les bornes au-delà de leur valeur de couple maximale de 15 pi-lb (180 po-lb). L'utilisation d'une visseuse à percussion ou d'outils électriques sur les bornes violera les modalités de la garantie. L'utilisation d'outils électriques ou de visseuses à percussion peut endommager la borne même si elle ne brise pas.

CAUTION

No material should be placed between the current carrying terminal and the cable lug or interconnecting busbars other than the provided copper washer for double lugged cables. Doing so will violate the terms of the Warranty.

ATTENTION

Aucun matériel autre que la rondelle en cuivre fournie pour les câbles à œillet double ne doit être mis entre la borne porteuse de courant et le serre-câble ou les barres omnibus d'interconnexion.

CAUTION

All SimpliPHI Batteries are designed to serve at fixed voltages and cannot be wired in series to increase the battery bank's voltage. Wiring the SimpliPHI Batteries in series will result in damage to the SimpliPHI Battery's protective circuitry and will violate the terms of the Warranty. SimpliPHI batteries are designed for parallel wiring only to increase the battery bank's storage capacity.

ATTENTION

Toutes les batteries SimpliPHI sont conçues pour fonctionner à des tensions fixes et ne peuvent pas être câblées en série pour augmenter la tension du banc de batteries. Le câblage des batteries SimpliPHI en série endommagera la circuiterie protectrice de la batterie SimpliPHI et violera les modalités de la garantie. Les batteries SimpliPHI sont conçues pour le câblage en parallèle seulement pour augmenter la capacité de stockage du banc de batteries.

CAUTION 

Only use a Briggs & Stratton approved LFP charger if ancillary charging is required at any point before or during installation, testing or troubleshooting. Failure to use a Briggs & Stratton approved LFP charger will damage the SimpliPHI Batteries and violate the terms of the Warranty.

ATTENTION

Utiliser un chargeur LFP Briggs & Stratton approuvé seulement si une recharge additionnelle est requise à tout moment avant ou pendant l'installation, la mise à l'essai ou le dépannage. Ne pas utiliser un chargeur LFP Briggs & Stratton approuvé endommagera les batteries SimpliPHI et violera les modalités de la garantie.

24

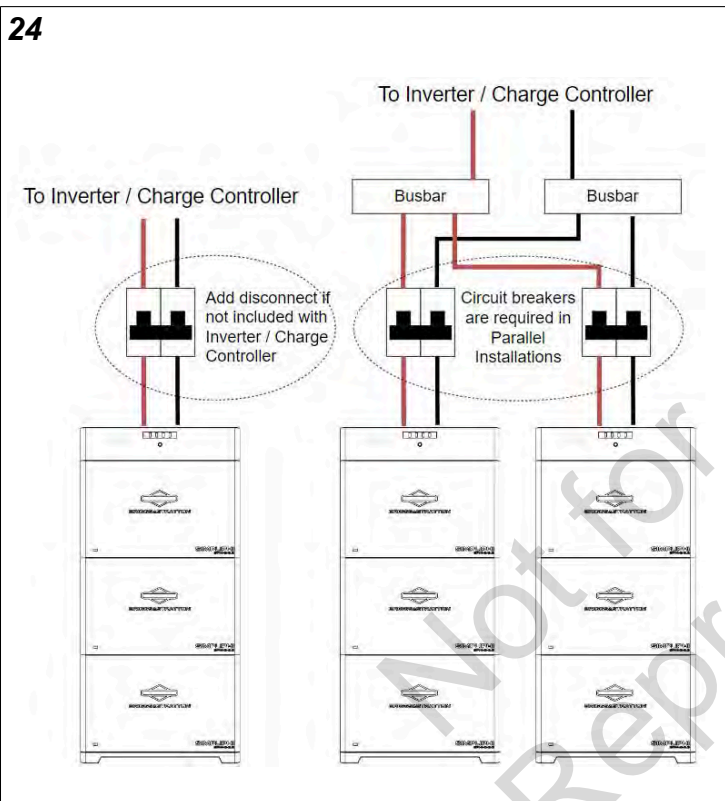

Single Stack Installation:

When connecting a single stack to a single charge controlling device with a built-in disconnect for the batteries, no external disconnect is necessary. If there is not a disconnect built-in to the charge controlling device, a disconnect must be installed between the battery stack and charge controlling device. This disconnect must be sized to the device with the lower rated current. If the disconnect sizing requirements are uncertain, refer to local AHJ and NEC guidelines.

When connecting a single stack to multiple devices, a disconnect is required between the battery stack and the charge controlling devices.

Batteries in Stack	1	2	3
Maximum Recommended Over-Current Protection Device Size	150 A	250 A	275 A

Parallel Stack Installation:

Up to 6 SimpliPHI 6.6 Battery Stacks can be wired in parallel from the terminals of the Controller to a properly sized combining busbar.

Between each stack and the busbar, a DC single-pole overcurrent protection device is required (double-pole is recommended). Follow local AHJ and NEC DC overcurrent protection device sizing requirements. The table above lists the recommended overcurrent protection device size per NEC 2023.

Make sure that all cable lengths from each stack are identical in length and gauge to maintain equal resistance across the stacks.

CAUTION 

Identical wire lengths and identical wire gauges from each SimpliPHI Battery in a SimpliPHI Battery System is a critical feature of parallel power storage systems that must be adhered to. Failure to properly wire the SimpliPHI Batteries in parallel can damage the system and will violate the terms of the Warranty.

ATTENTION

Chaque batterie dans un système de batteries SimpliPHI doit avoir des fils de longueur et de calibre identiques; c'est une caractéristique essentielle des systèmes de stockage d'énergie en parallèle qui doit être respectée. Ne pas bien câbler les batteries SimpliPHI en parallèle peut endommager le système et violera les modalités de la garantie.

Electrical Wiring instructions per stack:

1. Turn ON the SimpliPHI 6.6 BESS (hold power button on the Controller until all LEDs on batteries and Controller are ON.)
2. Measure the voltage at the Controller power terminals.

NOTE: If the SimpliPHI Battery's voltage has dropped to a voltage below the inverter's minimum starting voltage requirement, then the battery will need to be charged using an external charger. SimpliPHI batteries have a very low self-discharge rate and typically do not require ancillary charging, but an extended period in storage can cause the batteries to discharge.

3. Turn OFF the SimpliPHI 6.6 BESS. (Hold the power button on the Controller until the Controller LEDs are OFF.)
4. Measure the voltage at the Controller power terminals. The voltage will measure <5 VDC if the system is off.

Ground Cable Installation:

A grounding position is provided to comply with local AHJ and NEC grounding requirements. Ground as required.

5. Terminate the ground cable (sized to local AHJ and NEC requirements) with a 1/4" closed-end Ring Terminal. Cover the exposed wire between the lug and wire sheath with heat shrink.

- Attach the ground wire with the 1/4" ring terminal with the M5x10mm screw provided, as shown in Figure 25. Torque to 1.7 ft-lb maximum (20 in-lb).

25

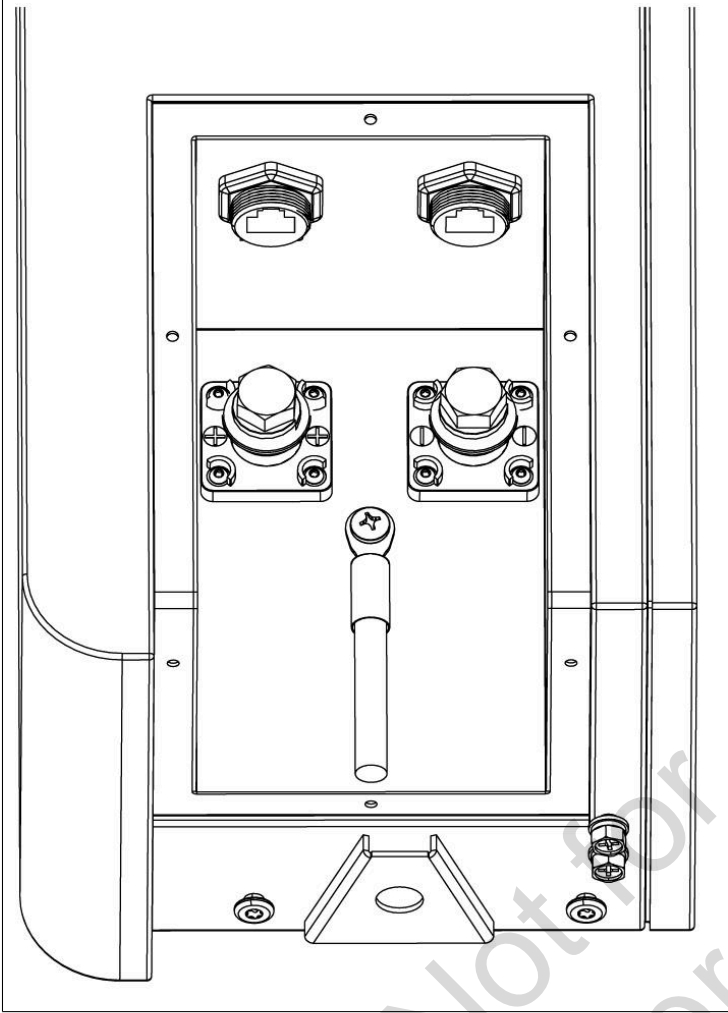

Power Cable Installation:

- Terminate the Negative and Positive cables (sized to local AHJ and NEC requirements) with a 3/8" closed-end Ring Terminal. Cover the exposed wire between the lug and wire sheath with heat shrink.

CAUTION

Do not use power tools or impact drivers to tighten the terminal hardware. This can result in damage to the terminal and will violate the terms of the Warranty.

ATTENTION

Ne pas utiliser d'outils électriques ou de visseuses à percussion pour serrer le matériel des bornes. Ce faire peut endommager la borne et violera les modalités de la garantie.

- Attach the Negative cable with the 7/16" ring terminal with the provided M10 x 30mm bolt, to the BLACK terminal as shown in Figures 26 and 27. Torque to 15 ft-lbs (180 in-lbs) maximum.

- Attach the Positive cable with the 3/8" ring terminal with the provided M10 x 30mm bolt, to the RED terminal as shown in Figures 26 and 27. Torque to 15 ft-lbs (180 in-lbs) maximum.

26

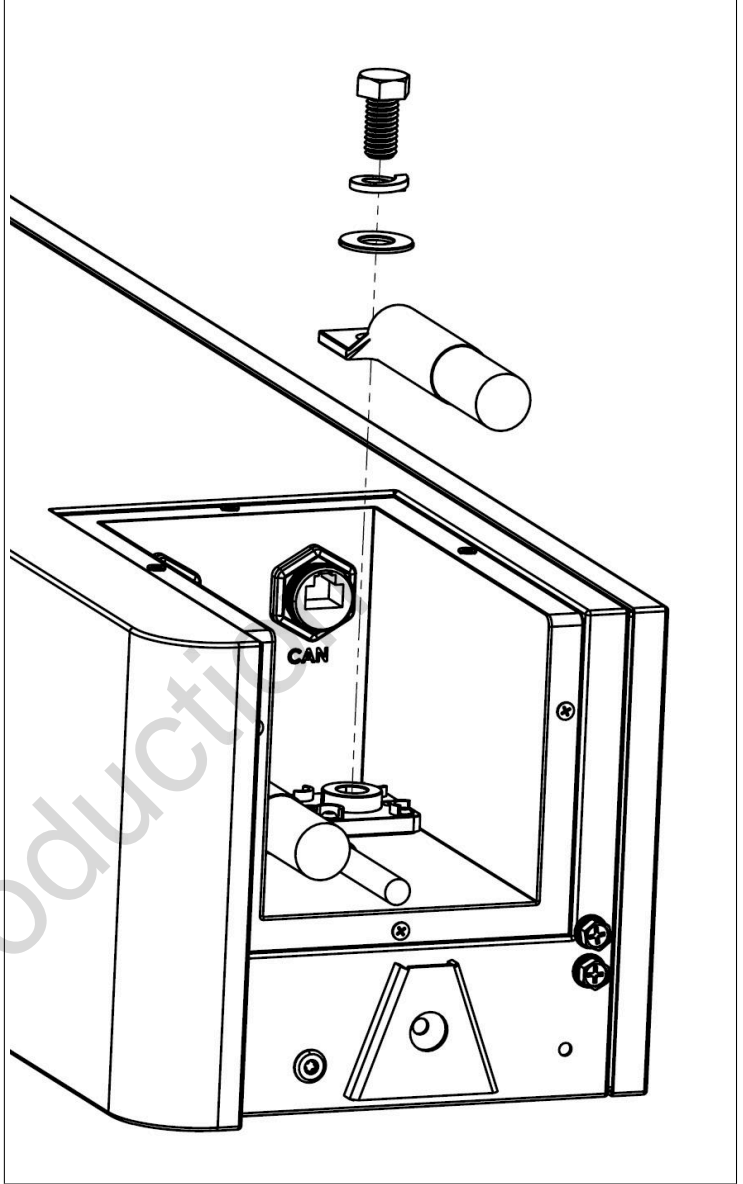

27

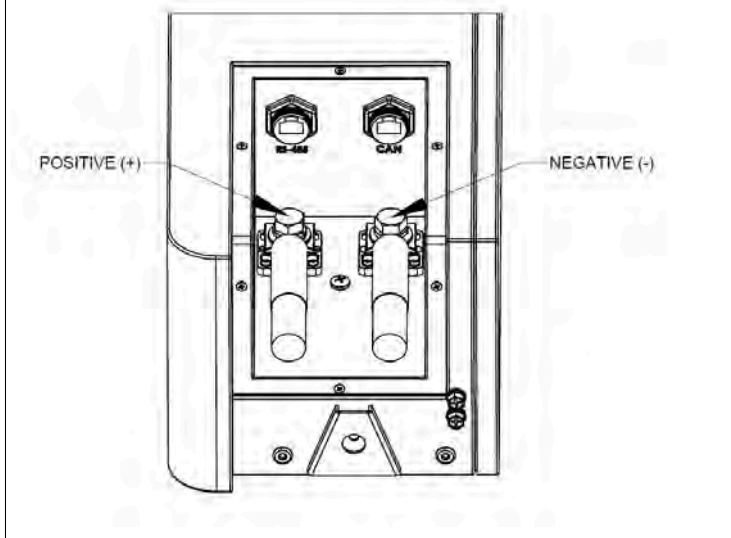

- For installations where double lugging cables are required, a copper washer is supplied with the Controller Unit. See Figure 28.

28

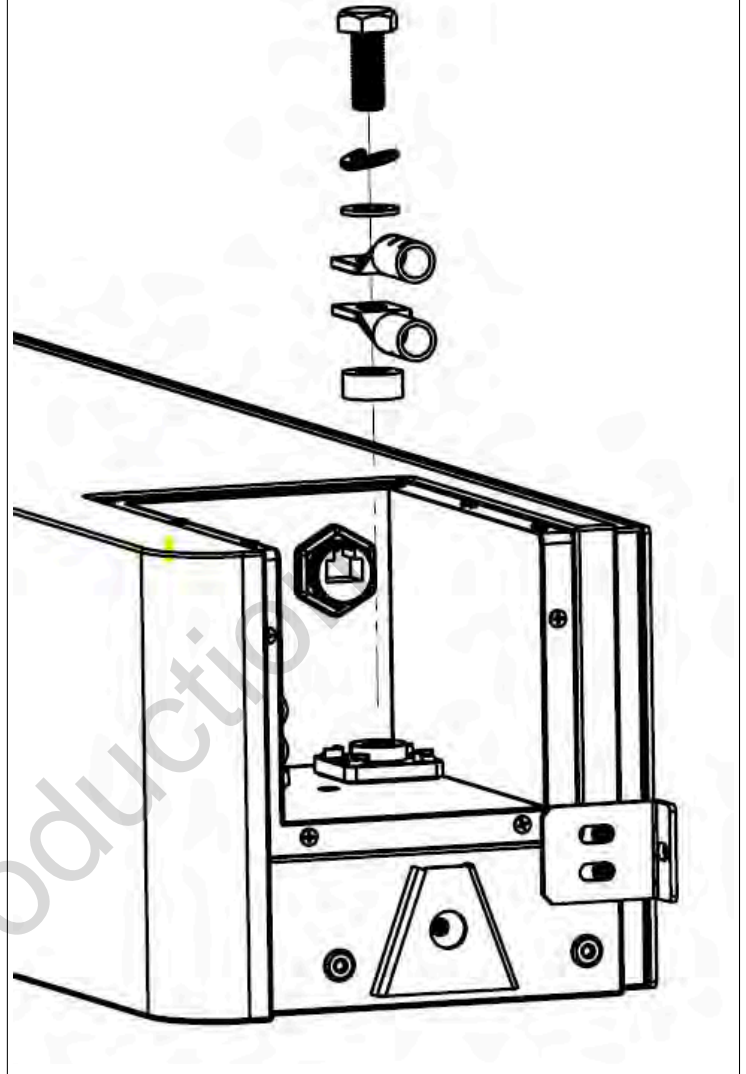

Communication Wiring Installation

Communication is not required for the SimpliPHI 6.6 Battery System to function. The communication enables enhanced functionality of the system and only works with the Briggs Stratton EnergyTrak Gateway and Inverters approved by Briggs & Stratton.

Each SimpliPHI 6.6 battery stack includes two RJ-45 ports, compatible with CAT5 (or greater) cable. One is labeled "CAN", the other is labeled "RS485".

Single Stack Installation with EnergyTrak (Figure 29):

- Install the provided Battery CAN Terminator in either the "CAN" or "RS485" RJ-45 port.
- Connect a CAT5 (or greater) cable between the unoccupied RJ-45 port on the Controller and the provided EnergyTrak Gateway Battery Communications Adapter.

3. Connect the provided EnergyTrak Gateway Battery Communications Adapter to the EnergyTrak gateway.

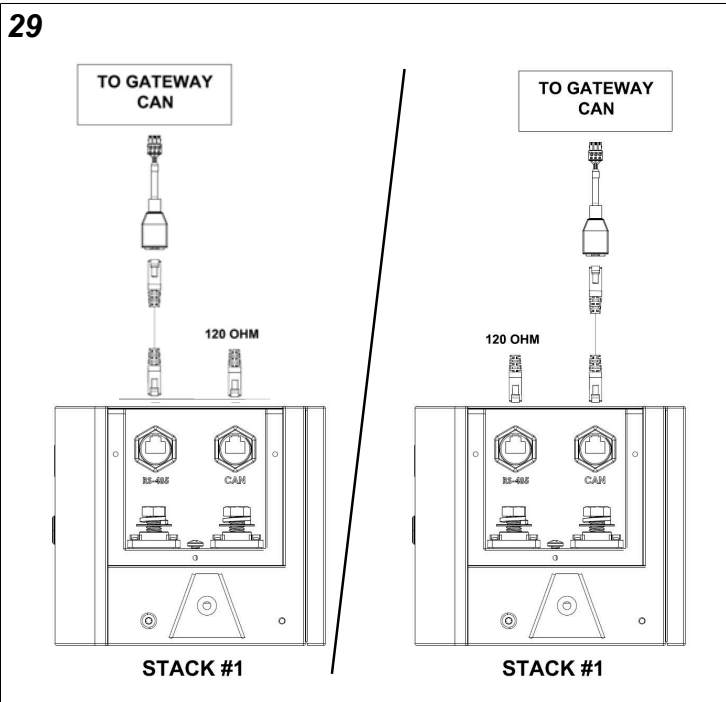

Single Stack Installation with Sol-Ark Residential Inverters and EnergyTrak (Figure 30):

1. Connect a CAT5 (or greater) cable to the “CAN” RJ-45 port on the Controller and to the provided Sol-Ark Battery Communications Adapter.
2. Connect the provided Sol-Ark Battery Communications Adapter into the CAN connector on the Sol-Ark inverter.
3. Connect a CAT5 (or greater) cable between the “RS485” RJ-45 port on the Controller and the provided EnergyTrak Gateway Battery Communications Adapter.
4. Connect the provided EnergyTrak Gateway Communications Adapter into the CAN connector on the EnergyTrak gateway.

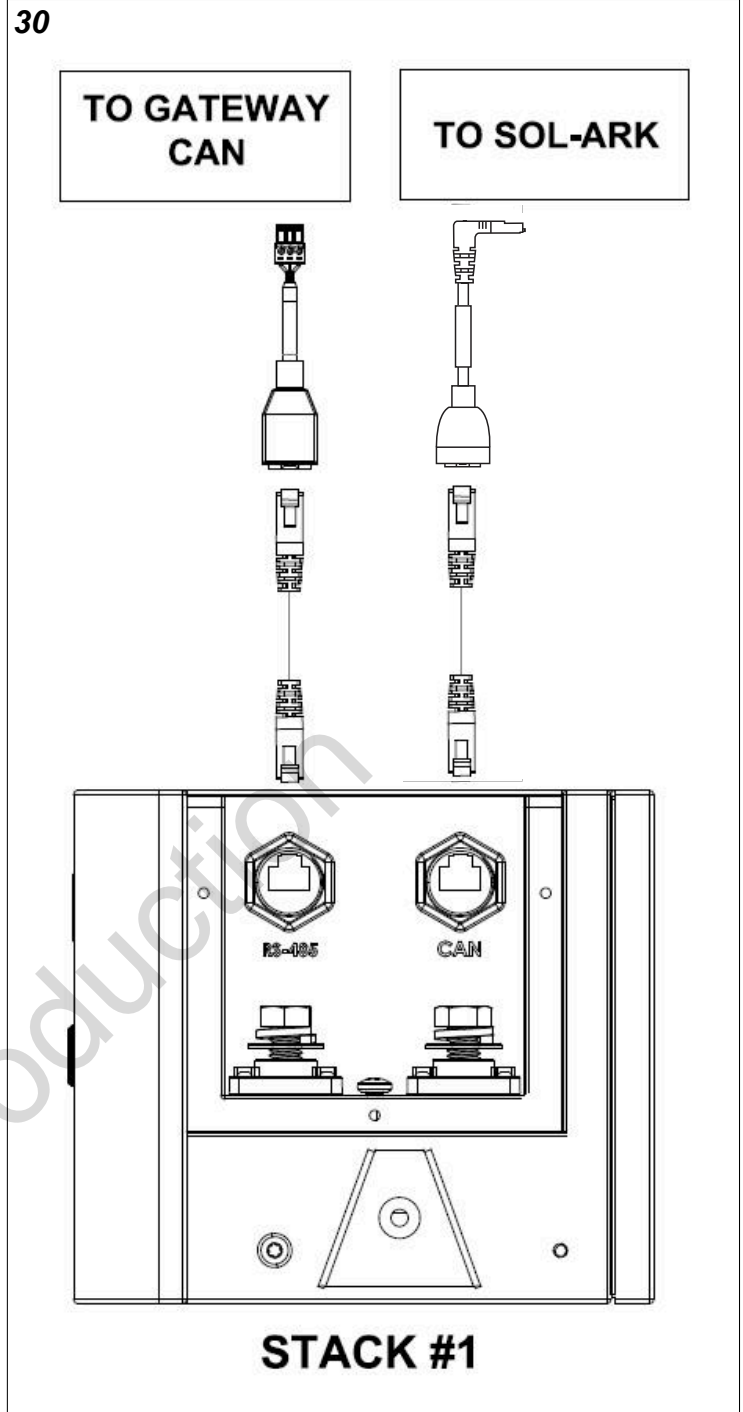

Multi-Stack Installations (Figure 31, 32 or 33):

For installations containing multiple stacks, the Controllers must be connected to each other via CAT5 (or greater) cables. In all configurations, all RJ-45 connectors must be occupied by a Battery CAN terminator, CAT5 connection to an adjacent battery stack, or a provided Battery Communications Adapter.

1. Connect the first stack to the inverter or EnergyTrak gateway from the port labeled CAN using the correct adapter provided.
2. Connect Cat5 (or greater) cable to the other port to daisy-chain to the next Controller. Both ports work for the daisy-chain.

31

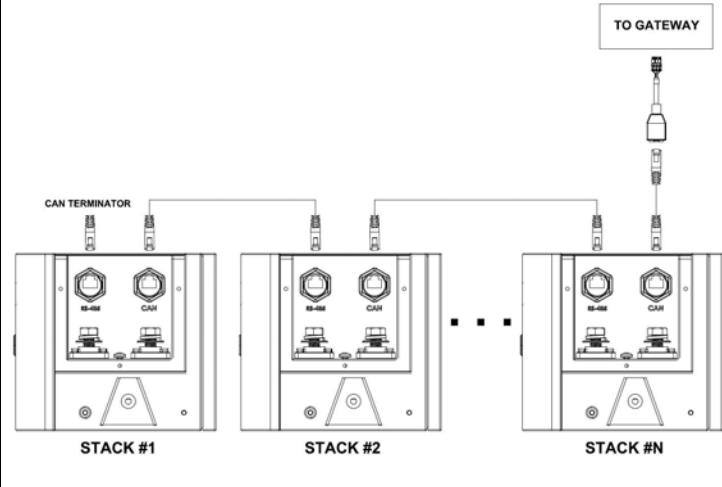

32

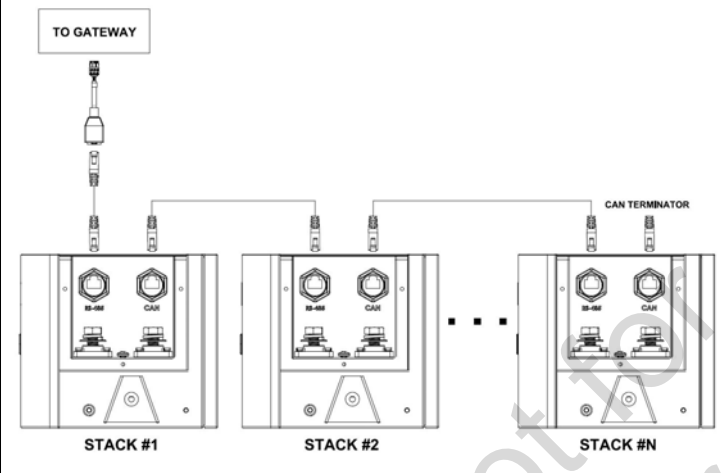

33

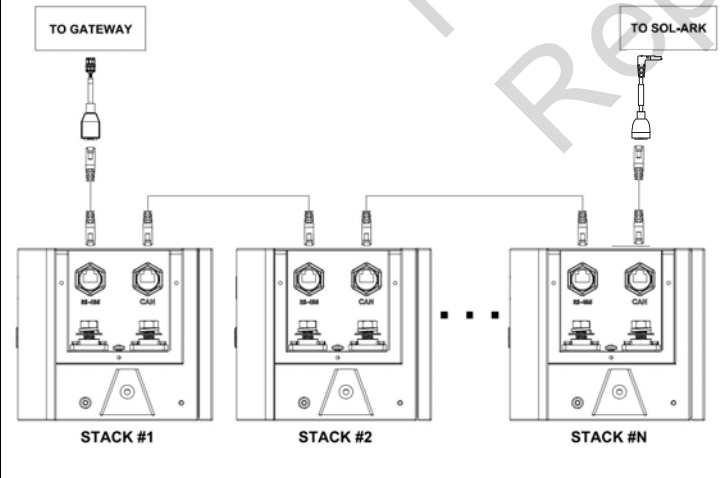

Finish the loop (Figure 34):

On the last stack, plug in the provided terminator to the last open RJ-45 port.

34

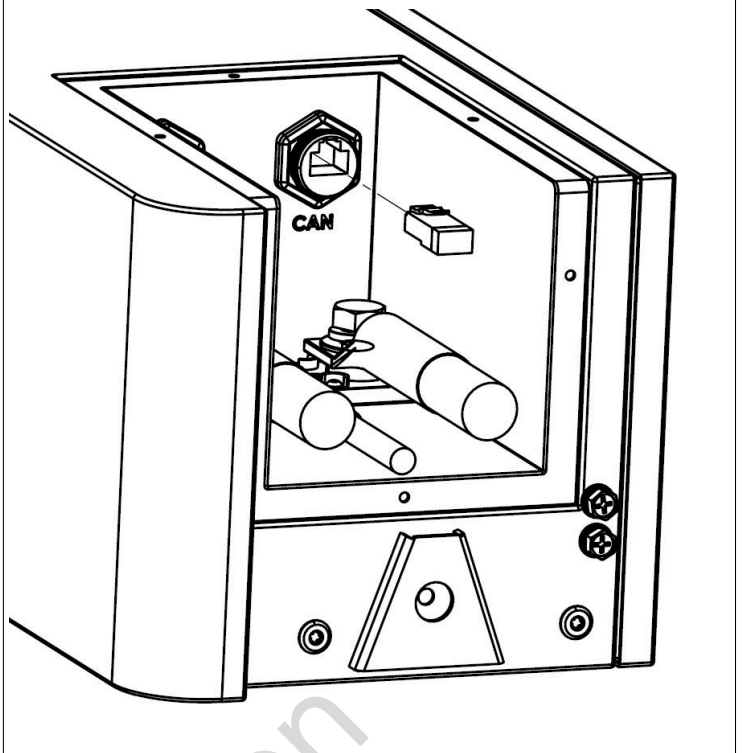

Once the communication wiring is complete, all RJ-45s must be occupied. This is true for single- and multi-stack installations.

Completing Installation

1. Double check to ensure the battery system is securely mounted and level.
2. Double check to ensure all power connections are properly torqued.
3. Double check to ensure all communication cables are fully plugged in and seated.
4. Double check to ensure the Positive, Negative, and Ground terminals are all "Open" (not shorted) (i.e. Pos-to-Neg, Pos-to-Ground, Neg-to-Ground)
5. Only after all wiring connections have been completed and double checked, reinstall the top plate using the 6 M3 x 8mm screws and a #1 Phillips screwdriver.

The installation of the SimpliPHI 6.6 Battery System is now complete. Please move on to *Programming and Commissioning*.

Programming and Commissioning

WARNING

SimpliPHI Batteries must be installed, wired and commissioned by a qualified installer or professional electrician who is familiar with general electrical safety precautions and specific regional code requirements.

AVERTISSEMENT

Les batteries SimpliPHI doivent être installées, câblées et mises en service par un installateur qualifié ou un électricien professionnel qui connaît les précautions de sécurité électrique générales et les exigences du code régional spécifiques.

Preparation: Make sure the loads and outputs of the inverter or charge controller are OFF during commissioning.

NOTE: Follow proper wiring guidelines and fully charge the SimpliPHI batteries prior to applying loads to ensure the system will not require any manual balancing. All SimpliPHI Batteries are balanced during final production and testing stages.

1. Make sure the SimpliPHI 6.6 BESS is OFF. (No LEDs on the batteries or Controller should be illuminated.)
2. Turn on the most stable energy source to the inverter and/or charge controller. This could be the connection to the grid or battery system. A stable grid connection is the most recommended. If required by the inverter, turn on the SimpliPHI 6.6 BESS (see step 5).
3. Turn on the inverter and/or charge controllers in the system.
4. If using a Briggs & Stratton Inverter, this step can be skipped. If using a 3rd-party inverter, check the inverter and/or charge controller charge settings. Make sure the settings are:

Setting	Recommended	Minimum	Maximum	Notes
Low Battery Cut-Out (LBCO) (VDC @ C/2, 23C)	48	45	50	
Low Battery Cut-Out Delay (sec)	10	0	120	With higher low battery cut-out voltages, a longer delay is allowed.
Low Battery Cut In (V DC)	LBCO + 3.0	LBCO + 2.0	Absorb Voltage	
Absorb Voltage (V DCO)	56.0	54.4	56.8	
High Battery Cut-Off (HBC) (V DC)	56.8	54.6	57.6	between .2 and .8 V above Absorb voltage
High Cut-In	HBCO - 0.4	HBCO - 0.8	HBCO - 0.2	

High Battery Cut-Out Delay (Sec)	0	0	10	
Absorb Time (minutes)	30	5	300	The lower the absorb Voltage, the longer the Absorb time must be
Float Voltage (VDC)	54.4	54	54.4	
Maximum Charge Current per Battery Module (A)	65.0	13.0	100.0	Limited to 273A per Controller
End of Charge Current (A)	1.3	1	2.6	
Equalization	Disabled			
Charge Efficiency (%)	99.99	99	100	Coulombic Efficiency
Depth of Discharge	80%	20%	100%	
Capacity (Ah)	130 x # of modules			
AC Internal Resistance (mΩ)	15 ÷ # of modules			
Estimated DC Internal Resistance (mΩ)	20 ÷ # of modules			DC Internal Resistance varies significantly based on factors including temperature, SOC, and C-rate and will be higher than AC Internal Resistance.
Maximum Charge Current per Battery Module (A)	PLEASE SEE APPENDIX FOR CHARGE AND DISCHARGE CURRENT VALUES BASED UPON STACK AND BATTERY COUNT			
Maximum Discharge Current (A)				

5. Turn on the SimpliPHI 6.6 BESS (hold down the power button) until all LEDs on the batteries and Controller are ON. Repeat for each stack.
6. Let the batteries charge and move on to EnergyTrak installations or installations without an EnergyTrak gateway.

CAUTION

Only use a Briggs & Stratton approved LFP charger if ancillary charging is required at any point before or during installation, testing or troubleshooting. Failure to use a Briggs & Stratton approved LFP charger will damage the SimpliPHI Batteries and violate the terms of the Warranty.

ATTENTION

Utiliser un chargeur LFP Briggs & Stratton approuvé seulement si une recharge additionnelle est requise à tout moment avant ou pendant l'installation, la mise à l'essai ou le dépannage. Ne pas utiliser un chargeur LFP Briggs & Stratton approuvé endommagera les batteries SimpliPHI et violera les modalités de la garantie.

EnergyTrak™ Programming and Commissioning

If utilizing a communications connected approved inverter with EnergyTrak gateway, follow the commissioning process outlined in the EnergyTrak manual. The commissioning is automated for ease.

Third-Party Inverter or Controller Programming and Commissioning

If utilizing batteries with a non-communicating third-party Inverter or EMS, program the controller with the values in the third-party Integration Guide and follow any processes or requirements outlined in the Inverter or EMS manual.

Operation

Turn ON / OFF Battery Stack

ON: Press the button on the Controller for over 10 seconds, until all battery LEDs and Controller LEDs are illuminated. See Figures 35 and 36.

OFF: Press the button on the Controller for over 10 seconds, until all battery LEDs are off. The Controller will turn OFF when the button is released.

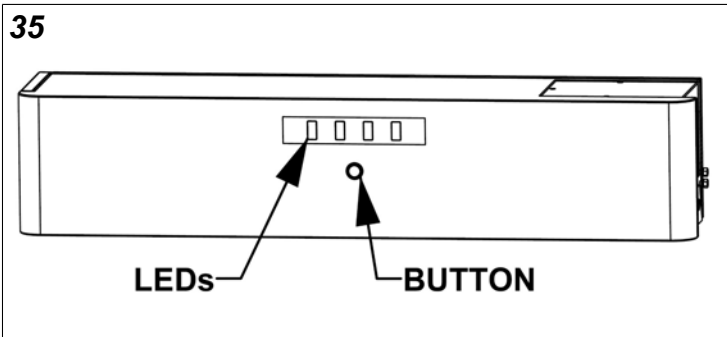

36

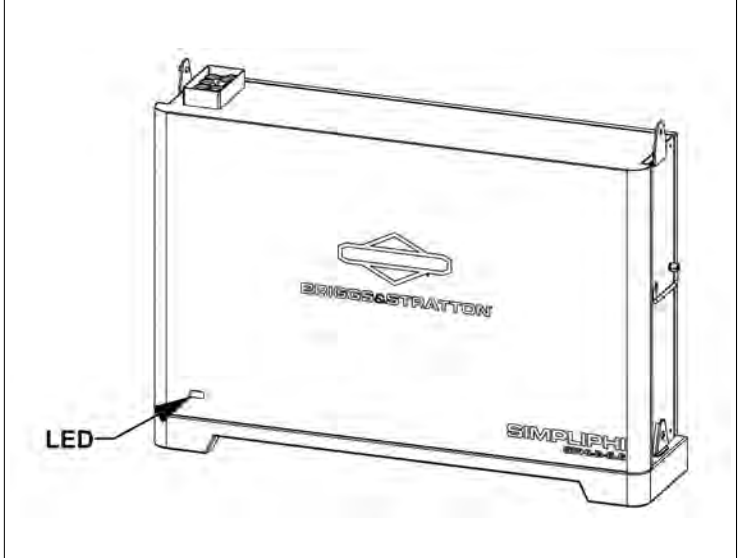

Controller LED Indicator

The Controller LEDs show the current SOC of the battery stack:

1 LED = 0-25%, 2 LED = 26-50%, 3 LEDs = 51-75%, 4 LEDs = 76-100%

If all of the LEDs are flashing, there is an issue. Please consult the Troubleshooting guide, the EnergyTrak app, or contact Technical Support.

Battery LED Indicator

The battery LED has 3 states:

ON: The battery is up, running, and healthy

OFF: The battery is off.

Blinking: There is an issue, please consult the Troubleshooting guide, the EnergyTrak app, or our Technical support.

Troubleshooting

Issue	Potential Resolution
Battery not providing voltage or power	<ol style="list-style-type: none">1. Verify polarity on the cables is correct. +/+ and -/-2. Press and hold the On/Off button until the LED status light turns green.
Battery indicating fault (flashing LED)	<ol style="list-style-type: none">1. Press and hold the On/Off button until the LED status light turns off2. Check EnergyTrak for the fault code3. Call Technical Support (805-640-6700 x 1, ESSTech@basco.com)

Battery not communicating with EnergyTrak gateway or Sol-Ark Inverter	<ol style="list-style-type: none"> 1. Be sure the unit is powered on by noting the green light on each battery module and use a DMM to measure that the voltage is within the operating range (46VDC - 58VDC). 2. Verify the communications cables have been properly plugged in. 3. Verify the communications cables have been made up properly with a data cable tester. 4. Confirm the terminating resistor (if required) has been installed in the correct location.
---	--

Appendix

# of Modules	Charge		Discharge	
	Current (A)	C-Rate	Current (A)	C-Rate
1	65	0.50	130	1.00
2	130	0.50	208	0.80
3	195	0.50	273	0.70
4	260	0.50	364	0.70
5	325	0.50	455	0.70
6	390	0.50	546	0.70
7	455	0.50	637	0.70
8	520	0.50	728	0.70
9	585	0.50	819	0.70
10	650	0.50	910	0.70
11	715	0.50	1001	0.70
12	780	0.50	1092	0.70
13	845	0.50	1183	0.70
14	910	0.50	1274	0.70
15	975	0.50	1365	0.70
16	1040	0.50	1456	0.70
17	1105	0.50	1547	0.70
18	1170	0.50	1638	0.70

Not for
Reproduction