



Installation Manual

AmpliPHI 3.8 kWh Batteries

SimpliPhi Your Energy Security and Independence

and gain control of your own power.

SimpliPhi Power helps you manage your power as a personal resource. Anytime. Anywhere. SimpliPhi energy storage optimizes integration of any power generation source – solar, wind, generator – on or off grid, and protects your home and mission-critical business functions from power outages and intermittency. SimpliPhi storage technology reduces operating temperature constraints, the risk of thermal runaway, and eliminates toxic coolants. Safe lithium ferrous phosphate (LFP). No cobalt. No toxic hazards.

SimpliPhi's battery technology utilizes the industry's most environmentally benign chemistry (LFP) combined with proprietary architecture and power electronics (BMS) to create a portfolio of high performance, scalable and enduring energy storage solutions that provide power security, resilience and daily cycling for savings on your utility bill.

SimpliPhi Power offers proprietary, commercially available energy storage and management systems that are safe, non-toxic, reliable, durable, efficient, highly scalable, and economical over the lifetime of the PHI Battery.

Table of Contents

- 1.0 – Introduction 5
- 1.1 – Online Resources 5
 - 1.2 – Technical Support 5
 - 1.3 – Product Overview 5
 - 1.3.1 – Battery Management System (BMS) 5
 - 1.3.2 – Built-In Breaker 6
 - 1.3.3 – Networking Communications Cables & Plugs 7
 - 1.4 – Specifications 7
- 2.0 – Safety 8
 - 2.1 – General Safety Instructions 8
 - 2.2 – Response to Emergency Situations 8
- 3.0 – Pre-Installation 9
 - 3.1 – AmpliPHI Battery Performance 9
 - 3.2 – AmpliPHI Battery System Sizing 9
 - 3.2.1 – Sizing for All Systems 9
 - 3.2.2 – Additional Sizing Considerations for AC Coupled Systems 9
- 4.0 – Installation 10
 - 4.1 – Installation Options 10
 - 4.2 – Environmental Considerations 10
 - 4.2.1 – Charging at Temperatures Below Freezing 10
 - 4.2.2 – Explosive Gas Precautions 11
 - 4.2.3 – Anti-Corrosion Protection 11
 - 4.3 – Mounting Hardware 11
 - 4.4 – Dimensions and Weight 12
 - 4.5 – AmpliPHI Battery Connection Terminals 12
 - 4.5.1 – Batteries with Threaded Studs 12
 - 4.5.2 – Torque Batteries with Threaded Studs 13
 - 4.6 – Electrical Wiring 13
 - 4.6.1 – Increasing Storage Capacity via Parallel Wiring 13
 - 4.6.2 – Parallel Wiring Batteries with Threaded Studs using Battery Cables 14
 - 4.6.3 – Parallel Wiring Batteries with Threaded Studs using Interconnecting Busbars 17
 - 4.7 – Communications Wiring 19
 - 4.8 – Battery System Commissioning 21
 - 4.9 – Battery Bank Expansion 23
- 5.0 – Programming 24
 - 5.1 – Operating Parameters per Warranty 24
- 6.0 – Troubleshooting 25
- Appendix A – AmpliPHI Battery Safety & Green Attributes, Certifications 26
- Appendix B – AmpliPHI Approved External Chargers 28



CAUTION: THIS MANUAL IS SPECIFIC TO THE AMPLIPHI BATTERIES THAT FEATURE INTERNAL COMMUNICATIONS WITHIN THE BMS. DO NOT FOLLOW THESE GUIDELINES IF YOU ARE USING THE STANDARD PHI PRODUCT LINE. PLEASE CONSULT THE INSTALLATION MANUAL SPECIFIC FOR YOUR BATTERIES FOUND HERE: [SIMPLIPHI PHI BATTERY INSTALLATION MANUAL LINK](#)



CAUTION: THESE 3 THINGS WILL VOID THE AMPLIPHI WARRANTY & DAMAGE THE BATTERIES. READ IN FULL PRIOR TO BATTERY INSTALLATION

The following abbreviated guidelines do NOT encompass all AmpliPhi battery Warranty details. Failure to adhere to the Warranty and Installation Manual requirements will Void the Warranty. Read the battery's complete Warranty prior to installation and register the battery according to the form found at the bottom of the same web page address: <https://simpliphipower.com/wp-content/uploads/documentation/ampliphi-series/simpliphi-power-ampliphi-3-8-warranty.pdf>

CAUTION: The following will result in damage to your PHI batteries and will **Void the Warranty:**

1. Incorrect battery wiring and/or installation

- a. Verify polarity at all connections with a standard voltmeter (1) before energizing the system and (2) on batteries with threaded stud connections, before switching the built-in circuit breaker to the "ON" position. Reverse polarity at the AmpliPhi Battery terminals will Void the Warranty and may permanently damage the AmpliPhi Batteries.
- b. AmpliPhi Batteries must be **fully charged before commissioning** (i.e. before connecting loads). Failure to do so will damage the AmpliPhi batteries and Void the Warranty.
- c. Lugs, washers and lug nuts must be installed according to the Installation Manual. Failure to do so will damage the PHI Batteries and Void the Warranty. Using an impact driver or power tools on the terminals will Void the Warranty. Using power tools or impact drivers may damage the terminal even if it doesn't result in breakage. **Only use accurately calibrated and properly adjusted torque wrenches when tightening terminal hardware.**

2. Pairing the battery with incompatible equipment. Use of accessories not recommended or sold by the manufacturer may result in a risk of fire, electric shock, or injury to persons and will Void the Warranty.

- a. Contact SimpliPhi Technical Support at (805) 640-6700 x 1 regarding the compatibility of any equipment not explicitly listed in the 'AmpliPhi Integration Guides' section of the Product Documentation web page (<https://simpliphipower.com/product-documentation/>).
- b. Refer to the SimpliPhi-Approved Chargers list (Appendix B of this document) for all compatible external / plug-in battery chargers. Use only a SimpliPhi-approved LFP battery charger if ancillary charging is required before installation, testing or troubleshooting. Failure to use a SimpliPhi-approved LFP battery charger will damage the AmpliPhi Battery and Void the Warranty.

3. Incorrect inverter and/or charge controller settings. Operating the AmpliPhi Battery in conjunction with equipment not programmed to the AmpliPhi Battery's settings will Void the Warranty.

- a. Refer to the 'AmpliPhi Integration Guides' section of the Product Documentation web page (<https://simpliphipower.com/product-documentation/>) for all inverter and charge controller settings.
- b. Although each AmpliPhi Battery contains an internal Battery Management System (BMS) with circuitry that protects the AmpliPhi Battery cells from over-charge, over-discharge and extreme load amperage, the AmpliPhi Battery must always be installed with appropriate inverter and/or charge controller settings and power electronics to protect the AmpliPhi Battery from open solar photovoltaic (PV) voltage and other high voltage charging sources.
- c. Failure to protect the AmpliPhi batteries from voltages higher than the battery voltage rating (48-56 VDC) will destroy the AmpliPhi batteries, cause electrical fires and Void the Warranty.

The AmpliPHI Battery Warranty does NOT cover product damage caused by mishandling or improper use per the Installation Manual, Integration Guides and Warranty, exposure to liquids, impacts from falling objects or from being dropped, or attempts to repair the battery by any party other than SimpliPhi. The complete list of Warranty Exclusions is included in the AmpliPHI Battery Warranty document: [\[Amplify Warranty Document\]](#)

1.0 – Introduction

1.1 – Online Resources

The Product Documentation section of SimpliPhi's web site (<https://simpliphipower.com/product-documentation/>) includes Specification Sheets, Warranties, Installation & Operator's Manuals, and Integration Guides for all SimpliPhi's current and legacy products.

SimpliPhi's YouTube channel (https://www.youtube.com/channel/UCcuCaLT_G3Hhumteh-pl5yg/videos) has instructional videos showing various steps of the battery installation process in detail.

1.2 – Technical Support

SimpliPhi Technical Support (805-640-6700 x 1, techsupport@simpliphipower.com) is available to take any questions regarding this manual or general installation questions. For assistance with battery system commissioning, SimpliPhi asks that a commissioning call be **scheduled ahead of time** with Technical Support.

We encourage you or your installer to contact SimpliPhi with any questions. We are committed to working with you and your installation team to achieve a safe, reliable storage system that will provide years of maintenance-free service that is covered by our Warranty terms & conditions.

1.3 – Product Overview

The AmpliPHI deep-cycle Lithium Ferro Phosphate (LFP) Battery is optimized with proprietary cell architecture, power electronics, Battery Management System (BMS) with communications, manufacturing materials and processes. This assures the highest grade and quality, longest cycle-life, greatest efficiency and freedom from material impurities, toxicity and hazardous risk. The AmpliPHI Battery is modular, lightweight and scalable. It provides power security and seamless integration of renewable and traditional sources of energy in conjunction with or independent of the grid.

1.3.1 – Battery Management System (BMS)

Each AmpliPHI Battery contains circuitry that protects the LFP cells from damaging conditions (overcharge, over-discharge, extreme load amperage, etc.). If pre-programmed BMS values are exceeded, the protective circuitry will shut down the flow of electricity to/from the AmpliPHI Battery. In some cases, the BMS will automatically resume the flow of electricity to/from the AmpliPHI Battery when the battery is no longer in damaging conditions. In other cases, the AmpliPHI Battery's self-protection mechanism will result in the battery's breaker tripping and requiring a manual re-set (refer to Section 6.0 - Troubleshooting of this Manual for manual re-set instructions).

Regardless, once AmpliPHI Battery operation resumes and the connected inverter is back on, SimpliPhi recommends checking that the inverter's settings are still correct. Often, inverter system settings will be saved within the inverter memory storage and will not need to be reset. Refer to SimpliPhi's AmpliPHI Integration Guides for inverter and/or charge controller settings (<https://simpliphipower.com/product-documentation/>).



CAUTION: Although each AmpliPHI Battery contains an internal communications based BMS with circuitry that protects the AmpliPHI Battery cells from over-charge, over-discharge and extreme load amperage, the AmpliPHI Batteries must always be installed with appropriate inverter and/or charge controller settings to protect the AmpliPHI Battery from open PV voltage and other high voltage charging sources. Exposure to higher voltage than the AmpliPHI battery rating (48-56 VDC) will Void the Warranty and may damage the AmpliPHI batteries..

1.3.2 – Built-In Breaker

AmpliPHI batteries are outfitted with a hydraulic/magnetic circuit breaker. This breaker increases safety during shipping and installations and allows the battery to effectively be turned “OFF” or “ON.” The breaker works in conjunction with the battery’s built-in BMS and creates additional safety, efficiency and functionality in the overall power storage system.

Figure 1.0 – AmpliPHI 3.8 Circuit Breaker



NOTE: Circuit breakers, disconnects and fuses should be employed throughout several points of a power storage and generation installation to effectively isolate and protect all components of the system to safeguard against faults, short circuits, polarity reversals or a failure of any component in the overall system. Fuses, breakers, wiring ratings and values should be determined by established electrical codes and standards and evaluated by certified electricians, installers, and regional code authorities.

1.3.3 – Networking Communications Cables & Plugs

Each AmpliPHI battery comes with a 4’ CAT5 cable, a terminator plug, and an RJ45 dust cover for networking communication set-up (explained in greater detail in Section 4.7 – Communications Wiring).

1.4 – Specifications

Please review Table 1.0 below for AmpliPHI Battery specifications, including physical dimensions, Warranty period, and technical data.

Table 1.0 - AmpliPHI Battery Specifications

AmpliPHI 3.8™ (51.2V _{nominal})		AmpliPHI 3.8™ Internal BMS	
DC Voltages - Nominal	51.2 VDC	Programmed Absorb Voltage	56 VDC
Amp-Hours	75 Ah	Programmed Float Voltage	54 VDC
Rated Capacity	3.8 kWh DC at 100% DoD	Over-Voltage Fault Trip ²	60 VDC
	3.04kWh DC @ 80% DoD		
MAX Discharge Rate (10 minutes)	100 Amps DC (5.1 kW DC)	Low-Voltage Fault Trip ²	45 VDC
MAX Continuous Discharge & Charge Rate	37.5 Amps DC (1.9 kW DC)	Programmed Discharge & Charge Rate per battery ²	37.5 Amps DC (1.9 kW DC)
DC Voltage Range ¹	48 to 56 VDC		
Depth of Discharge ¹	up to 100%		
Self-Discharge Rate	< 1% per month (<i>with battery off</i>)	Charging Low Temperature Fault Trip ²	32° F (0° C)
Charging Temperature ¹	32° to 120° F (0° to 49° C)	Discharging Low Temperature Fault Trip ³	-4° F (-20° C)
Operating Temperature ¹	-4° to 140° F (-20° to 60° C)	High Temperature Fault Trip ³	158° F (70° C)
Storage Temperature	6 months: 14° to 77° F (-10° to 25° C) 3 months: -4° to 113° F (-20° to 45° C)		
Memory Effect	None	Maximum Quantity of Networked Batteries	40
Cycle Life	10,000+ cycles (@ 80% DoD)	Networking Cable	CAT5 or
Warranty Period	10 Years	Networking Port	RJ45
Weight	86 lbs. (39 kg)		
Dimensions (W x H x D)	13.5 x 14 x 8 in.		
	(15.5” H w/terminals) / 0.88 ft ³		
	(34.3 x 35.6 x 20.3 cm / 0.025 m ³)		

Notes:

¹ Max operating ranges. Operating outside of these conditions will Void your Warranty.

²These AmpliPHI BMS Fault Trip conditions result in the need for the BMS to be re-set **manually** (refer to Section 6.0 - Troubleshooting of this Manual)

³These AmpliPHI BMS Fault Trip conditions result in automatic BMS reconnection when fault conditions are no longer detected. There is no need to re-set the BMS manually in these instances.

Specifications are typical/nominal. Subject to change without notice.

2.0 – Safety

For safety reasons, read all instructions and cautionary markings on the AmpliPHI Batteries, and all appropriate sections of this manual. Failure to follow instructions provided in the Installation Manual, Integration Guides and/or Warranty will Void the Warranty.

2.1 – General Safety Instructions

- Do not operate if the AmpliPHI Battery has been damaged in any way during shipping or otherwise.
- To reduce the chance of short-circuits, always use insulated tools when installing or working with AmpliPHI batteries or other electrical equipment.
- Remove personal metal items such as rings, bracelets, necklaces, and watches when working with AmpliPHI batteries and electrical equipment. Wear insulated gloves and rubber shoes.
- AmpliPHI Batteries pose some risk of shock or sparking during the installation and initial wiring and connection process. This is consistent with all other battery-based storage formats. To minimize the risk of shock or sparks during the installation and commissioning of the system, make sure the built-in breaker is in the “OFF” position.
- To avoid a risk of fire and electric shock, make sure that existing system wiring is in good condition and that the wire is not undersized. Do not operate the AmpliPHI Battery in conjunction with damaged or substandard wiring.

These safety precautions are in addition to the Warnings previously outlined on page 4 of this Manual.

2.2 – Response to Emergency Situations

As with any battery, if the AmpliPHI Battery’s cells are severely damaged due to physical abuse, reverse polarity, high voltage, unmitigated current or other electrical phenomenon incurred outside of Warranted specifications, it can cause electrolyte leakage and other failures. The electrolyte can be ignited by an open external flame. However, unlike other lithium ion batteries with cobalt oxides (e.g. LCO, NCM and NCA), the AmpliPHI LFP Batteries’ electrolyte and other material components generate a limited amount of heat and do not go into a state of thermal runaway with fire propagation. The SimpliPhi UL 1973 Battery Certification verifies “No Thermal Runaway” (see MSDS for chemical analyses).

While PHI Batteries do not go into thermal runaway with fire propagation, the following protocol should be followed in the event that the PHI batteries are subjected to electrical fire caused by other system components or failures:

- Ensure that the system is no longer energized, either from the solar array or the grid (main disconnect).
- Separate any external cables from batteries if present (cut if necessary) using insulated tools.
- Wear a respirator or dust mask to avoid inhaling soot/dust.
- Wear insulating and abrasion-resistant gloves (if permeable, over nitrile or similar gloves).
- Move battery debris into non-conductive bins capable of handling the weight.
- Dispose as regulations require.



CAUTION: While water is an acceptable and effective extinguishing agent for the AmpliPHI Battery model, the Balance of System equipment used in conjunction with the AmpliPHI Batteries may require specialized extinguishers such as FM-200 or CO2 suppression systems.

3.0– Pre-Installation

3.1– AmpliPHI Battery Performance

AmpliPHI Batteries do not need to be de-rated unless running continuously at more than 90% capacity. To achieve the greatest cycle life of 10,000 cycles, AmpliPHI Batteries are typically operated at 80% maximum Depth of Discharge.

Due to the AmpliPHI Battery's internal self-protection mechanisms, the battery will not charge when internal battery temperatures are below 32° F (0° C), will not discharge when internal temperatures are below -4° F (-20° C), and will not charge or discharge when internal temperatures exceed 158° F (70° C). When connected to an approved inverter, the AmpliPHI battery will automatically curtail charge rates to 20A when the internal temperature drops between 32° - 44.6° F (0° - 7° C). The battery will continue to charge at reduced rates of 3A from 14° - 32° F (-10° - 0° C) and 1A from -4° - 14° F (-20° - 10° C). Strategies such as proper insulation of battery enclosure and/or capture of residual heat from other power electronics within the enclosure can mitigate temperature concerns in cold climates.

All AmpliPHI Batteries are balanced during final production and testing stages. Following proper wiring guidelines ensures that a system will not require any manual balancing processes.

3.2– AmpliPHI Battery System Sizing

AmpliPHI Batteries are designed to operate at the continuous ratings specified in Table 1.0 – AmpliPHI Battery Specifications. AmpliPHI batteries with communications, when paired with an approved inverter will enable proper settings for any size battery bank up to **40 battery modules**. Settings also specified in Table 1.0 will be automatically communicated to the inverter. Battery bank sizes larger than 40 battery modules are not supported as sufficient communications to the inverter and between the batteries cannot be achieved.



CAUTION: An AmpliPHI Battery bank cannot exceed 40 modules per bank. Sizing AmpliPHI battery banks larger than 40 battery modules potentially causes damage to the AmpliPHI batteries and Voids the Warranty.

3.2.1 – Sizing for All Systems

AmpliPHI batteries in DC Coupled or AC Coupled Systems should be sized according to the connected loads' energy (kWh) and power (kW) requirements. While as few as one AmpliPHI battery may be paired with compatible equipment without voiding the battery warranty, consider that the AmpliPHI battery is rated according to the specifications listed in Table 1.0 above, and that, without a backup AC power source, loads that exceed the battery bank's total capacity or power rating will result in the entire system shutting down. For additional system sizing recommendations, refer to Section 3.2 in the standard [PHI Battery Installation Manual](#).

3.2.2 – Additional Sizing Considerations for AC Coupled Systems

In an AC Coupled system, significantly limiting the solar array's charging power does not work well. In addition, because the solar charging cycle in an AC coupled system will frequently have minimal absorb time, the level of charge achievable with a full absorb is not equivalent to the battery's 100% SoC. This effect is less significant at slower charging rates. Therefore, SimpliPhi recommends sizing a larger battery bank relative to the AC Coupled PV array. In the below AC Coupling example, the batteries' typical maximum continuous charge rate is multiplied by a de-rate factor of **0.8**.

The charge calculation uses the nomenclature below:

- Battery maximum continuous charge rate (kW_{DC}) = Bat_{kW} (typically @ C/2)
= (maximum battery charge current × battery voltage nominal)
- PV charge maximum = PV_{kW}

Charge Example: $B_{\#PV} \geq \frac{PV_{kW}}{0.8 \times Bat_{kW}}$

- AC Coupled Solar PV Array is rated at 8 kW
- AmpliPHI 3.8 battery has a maximum continuous charge rate of 1.92 kW_{DC}

$$B_{\#PV} \geq \frac{8_{kW}}{0.8 \times 1.92_{kW}} = 5.2$$

A properly sized AmpliPHI battery bank based on the maximum charge from the AC Coupled solar PV array has a minimum of 6 batteries. This helps ensure that the battery bank receives as much charge as possible from the AC Coupled solar PV.



CAUTION: Using fewer than the calculated number of PHI batteries in this AC Coupled charge calculation may result in limitedly effective charging from AC coupled PV in Off-Grid or Grid-Outage conditions.

When the output of the AC Coupled Solar PV array exceeds the **MAX A Charge** parameter, and frequency shift is unable to mitigate the output, the battery charging will be interrupted. To avoid this, PV Array sizing needs to be adjusted to accommodate the **MAX A Charge** parameter for the overall system.

Homeowners with little to no loads on during the day (while solar power production is at its peak) might consider sizing a larger AmpliPHI battery bank to take advantage of the entire solar PV output potential for battery charging. Homeowners that consistently power loads during peak solar power production times may require a smaller sized battery bank.

4.0 – Installation

4.1 – Installation Options

The AmpliPHI 3.8 Batteries can be mounted in practically any orientation (terminals up or on any side), with no impact to the performance of the AmpliPHI Battery. **Do not install them upside down**, with the terminals facing the floor. A maximum of **40 AmpliPHI** batteries can be connected together via their communications cables to an approved inverter.

4.2 – Environmental Considerations

4.2.1 – Charging at Temperatures Below Freezing

The AmpliPHI Battery’s internal BMS and protective circuitry prevent it from charging below 32° F (0° C) and discharging below -4° F (-20° C), unless connected to an approved inverter. Therefore, SimpliPhi recommends installing the battery in conditions where ambient temperature does not drop below freezing in order to maintain AmpliPHI battery system operability.



CAUTION If the AmpliPHI Battery must be charged below 32° F (0° C), the rate of charge must be at no more than 5% of the PHI Battery's rated capacity (C/20), or be connected to an approved battery. Not doing so will Void the Warranty.

4.2.2 – Explosive Gas Precautions

AmpliPHI Batteries are not ignition protected. To prevent fire or explosion, do not install this product in locations that require ignition-protected equipment. This includes any confined space containing vented batteries, or flammable chemicals such as, natural gas (NG), liquid petroleum gas (LPG) or gasoline (Benzine/Petrol).

Do not install in a confined space with machinery powered by flammable chemicals, or storage tanks, fittings, or other connections between components of fuel or flammable chemical systems.

AmpliPHI Batteries do not vent any harmful gasses and do not require special ventilation or cooling.

4.2.3 – Anti-Corrosion Protection

Anticorrosive compounds or epoxies are occasionally used in harsh or marine climate installations. Please consult your electrician or qualified installer to determine if this is advisable, and if so, what solution best suits your application.



CAUTION: Do not combine AmpliPHI Batteries with other brands, chemistries, or models (including the standard PHI model batteries). Do not mix AmpliPHI Batteries from different installations, clients or job sites. Either of these combinations will Void the Warranty.

4.3 – Mounting Hardware

AmpliPHI Battery mounting brackets (sold separately) are designed to secure one AmpliPHI 3.8 to a load bearing surface. The brackets can be mounted directly to a wall or can be arranged on strut channels for ease of positioning (mounting hardware not included). Mounting brackets should be mounted into load bearing beams, studs or solid materials with appropriate fasteners. A qualified installer should be familiar with accomplishing this with the appropriate load bearing requirements. SimpliPhi Power is not liable for damage caused by the inappropriate installation of mounting of brackets. Refer to Table 2.0 and Figure 2.0 for AmpliPHI Battery and mounting bracket dimensions and weights.

During mechanical testing, individual AmpliPHI 3.8 Mounting Brackets were exposed to 200 pounds each of downward pressure along the bracket's outer edge. During this test, a deflection of approximately 30 thousandths of an inch was measured. Bracket sets are designed to hold one AmpliPHI 3.8 Module with a weight of 86 pounds.

4.4 – Dimensions and Weight

Table 2.0 – Specifications: AmpliPHI 3.8 Battery w/ Mounting Bracket

	PHI 3.8 Battery	PHI 3.8 Battery w/ Mounting Bracket
Width	13.5"	13.7" (18" with mounting flanges)
Height	15.5" (including 1.5" terminal height)	15.75" (including 1.5" terminal height)
Depth	8"	9"
Weight	78.2 Pounds	86.2 pounds

Figure 2.0 – PHI 3.8 Mounting Bracket Assembly

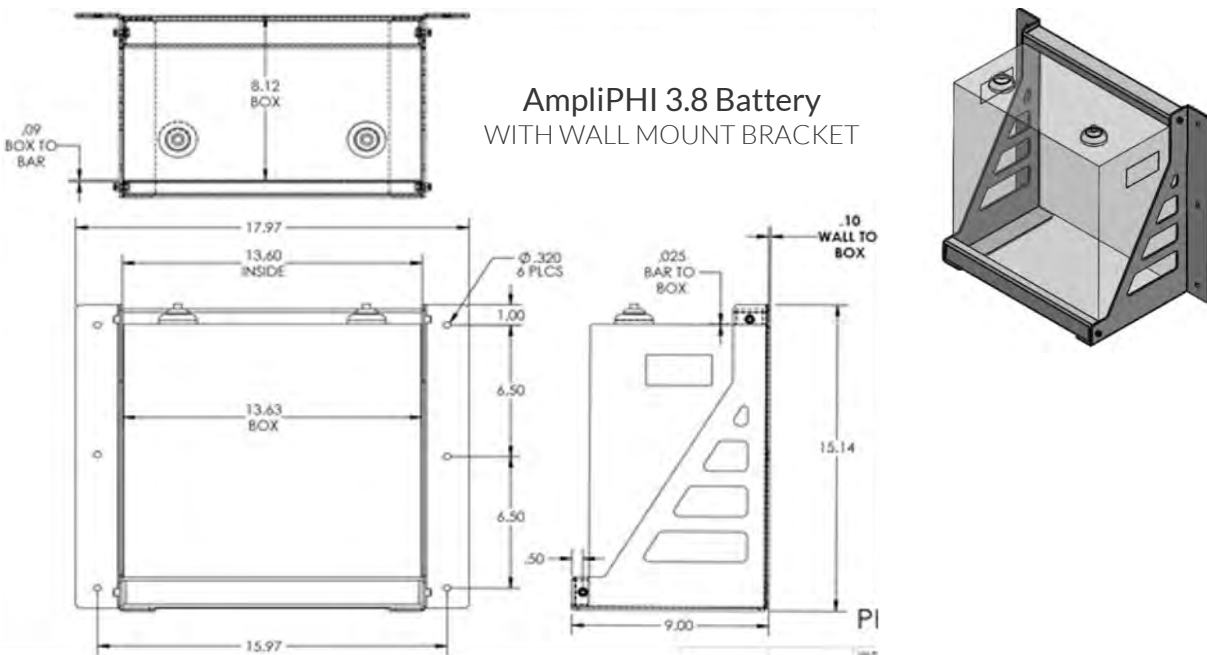

4.5 – AmpliPHI Battery Connection Terminals

4.5.1 – Batteries with Threaded Studs

The AmpliPHI Battery is equipped with two 3/8" (10 mm) threaded studs with a lock washer and nut. The red colored high temperature molded insert connection is for the positive lead. The black colored high temperature insert connection is for the negative lead.

Water resistant cable boots are also included and will be in place when your units arrive. The boots are to be placed over the cable terminations and will stretch to form a water-resistant seal around the base of the molded inserts and terminal connections.



CAUTION: Using an impact driver or power tools on the terminals will Void the Warranty. Using power tools or impact drivers may damage the terminal even if it doesn't result in breakage. Only use accurately calibrated and properly adjusted torque wrenches when tightening terminal hardware.

4.5.2 – Torque Batteries with Threaded Studs

AmpliPHI Batteries with threaded stud terminals have a torque specification of 121 in-lbs. (13.3 ft-lbs.).

Figure 3.0 – AmpliPHI Threaded Stud



Threaded Studs = 3/8" (10mm)

Torque Value = 160 in-lbs

4.6 – Electrical Wiring



CAUTION: All AmpliPHI Batteries are designed to serve at fixed voltages and cannot be wired in series to increase the battery bank's voltage. Wiring the AmpliPHI Batteries in series will result in damage to the AmpliPHI Battery's protective circuitry and will Void the Warranty. AmpliPHI batteries are designed for parallel wiring only to increase the battery bank's storage capacity.

4.6.1 – Increasing Storage Capacity via Parallel Wiring

Storage Capacity and total available **Amperage** is increased incrementally with the number of units wired in Parallel. For example, two AmpliPHI 3.8 kWh-51.2V_{nominal} (75Ah) Batteries wired in parallel are rated at a combined 7.6 total kWh, 51.2 Volts DC and 150Ah. The two paralleled PHI 3.8 kWh-51.2V_{nominal} batteries have a combined maximum continuous charge and discharge rate of 75 Amps DC (2 × 37.5ADC).

4.6.2 – Parallel Wiring Batteries with Threaded Studs using Battery Cables

AmpliPHI Batteries are paralleled by wiring from individual AmpliPHI Batteries to DC busbars or plates, which may be located in a DC combiner box or the inverter’s power panel.

Figure 4.0 – Two AmpliPHI Batteries in Parallel

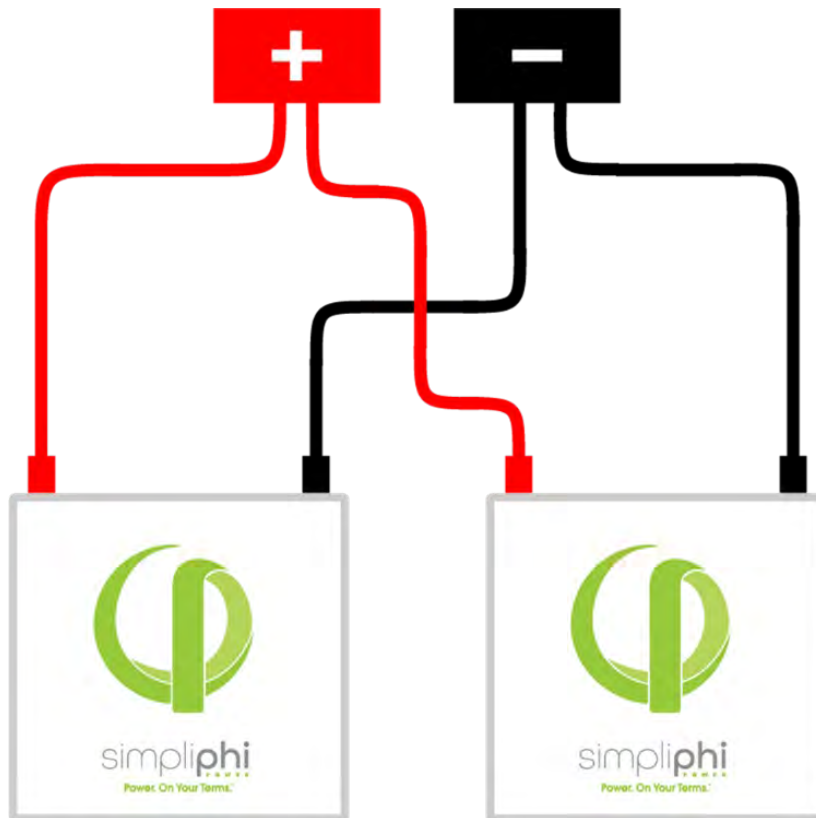

Although lead acid batteries are typically wired using battery-to-battery interconnecting cables, SimpliPhi asks that AmpliPHI Batteries NOT be wired in this way (in series).

Figure 5.0 – Incorrect AmpliPHI Wiring

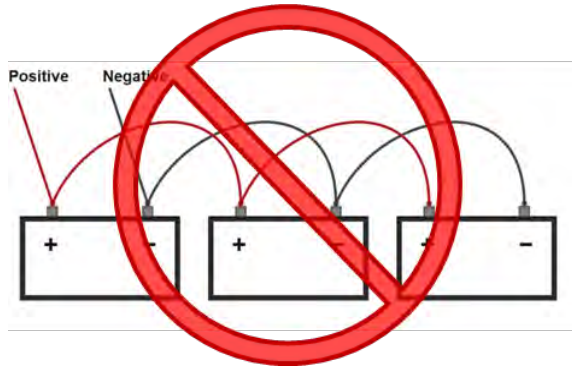

All wire lengths from each AmpliPhi Battery to common busbars or plates should be **identical in length and gauge** in order to balance the load across (all) AmpliPhi Batteries in the installation.



CAUTION: Identical wire lengths and identical wire gauges from each AmpliPhi Battery in an AmpliPhi Battery bank is a critical feature of parallel power storage systems that must be adhered to throughout all parallel wiring instructions. Failure to properly wire the AmpliPhi Batteries in parallel will Void the Warranty.

Figure 5.0 depicts three AmpliPhi Batteries wired in Parallel to a terminal block. This configuration requires 8 identical lengths of identical gauge copper wire.

Figure 6.0 - Four PHI Batteries in Parallel

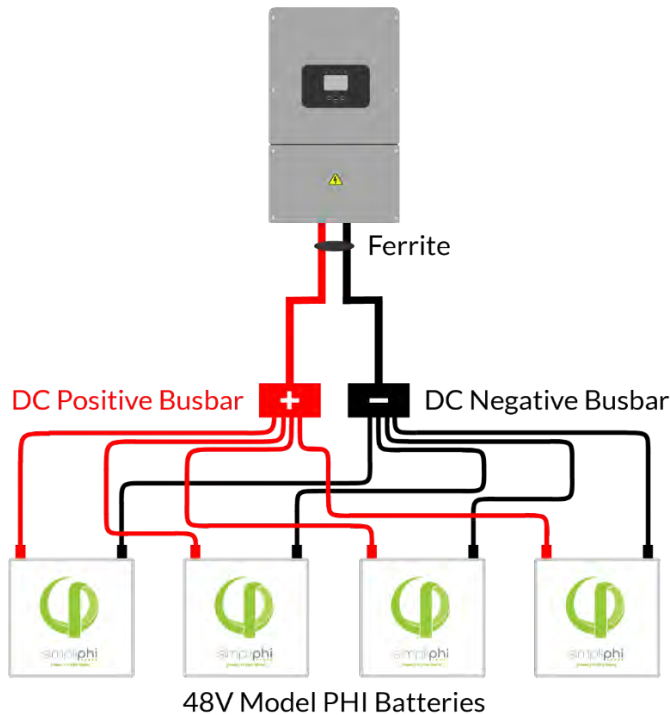

Helpful Tips:

- Power cabling for paralleling AmpliPHI Batteries is not included. All wire should be an appropriate gauge and construction to handle the loads that will be placed upon it. Heavy gauge, high strand copper wire is the industry standard due to its stability, efficiency and overall quality.
- Each PHI Battery's individual wire runs are typically sized at **4 AWG**, according to the 80A built-in breaker.
 - Conductor ampacity can be determined using National Electrical Code tables.
 - Depending on the electrical code of the local Authority Having Jurisdiction (AHJ), the AmpliPHI Battery leads' gauge may need to be sized according to the built-in breaker or according to the AmpliPHI Battery's surge rating.
- Battery cables from Spartan Power are flexible and easy to work with: <https://spartanpower.com/product/custom-battery-cables/>. Many of SimpliPhi's distributors also sell battery cables. Refer to the SimpliPhi Wiring Guide for a list of distributors that sell cables.
- Battery cables can be custom ordered to include the **3/8" lugs** that fit on the AmpliPHI Battery's threaded studs.
- Determine the cable length for the AmpliPHI Battery terminal farthest from the common busbar or plate first.
- Additional cabling or slack that remains with the shorter distance runs can be coiled and secured with Zip Ties.
- Wire length should be kept as short as practical.
- Positive wire runs should be separated from negative wire runs in separate conduit.
- Energy supplied by the AmpliPHI Battery is reduced as electrical current moves through wire. For lengths of battery cable greater than ~10 feet (3 meters), ensure that the voltage drop is no greater than 3%.
- To take full advantage of the combined AmpliPHI Battery bank's surge rating, the DC busbars or plates that the individual AmpliPHI Batteries are wired to should be rated to match the AmpliPHI Battery bank's total surge rating.
- MidNite Solar produces the [MNLB Lithium Battery Combiner](#) (rated at 250 Amps MAX) and the [MNBCB 1000/50 Battery Combiner](#) (rated at 1,000 Amps MAX)



CAUTION: Do not reverse polarity. Positive battery cables must connect to the AmpliPHI Battery's Positive terminal studs and to Positive DC busbars or plates. Negative battery cables must connect to the AmpliPHI Battery's Negative terminal studs and to Negative DC busbars or plates. Reversing polarity will Void the Warranty.

Figure 7.0 – Cable Lug Wiring onto AmpliPHI Threaded Stud



CAUTION: No material (such as a washer) should be placed between the current carrying terminal and the cable lug or interconnecting busbar. Doing so will Void the Warranty.



CAUTION: Sparks may be present when connecting wires to AmpliPHI Battery terminals. Be sure the battery's built-in circuit breaker is in the OFF position to minimize the risk of shock or sparks during system installation.



CAUTION: Using an impact driver or power tools on the terminals will Void the Warranty. Using power tools or impact drivers may damage the terminal even if it doesn't result in breakage. Only use accurately calibrated and properly adjusted torque wrenches when tightening terminal hardware.

4.6.3 – Parallel Wiring Batteries with Threaded Studs using Interconnecting Busbars

AmpliPHI Batteries can be paralleled using common bussing directly attached to the batteries' terminals. Interconnecting busbars for paralleling either two (SKU #BB-2) or three (SKU #BB-3) AmpliPHI batteries with threaded studs are available from SimpliPhi at an additional cost.

Figure 8.0 – AmpliPHI Wiring using Interconnecting Busbars

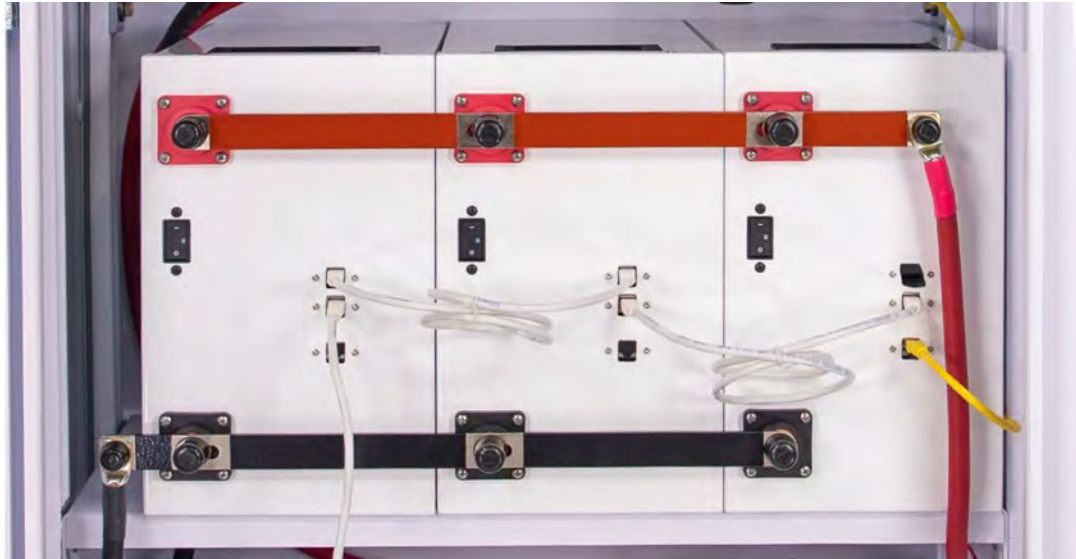

CAUTION: Again, no material (such as a washer) should be placed between the current carrying terminal and the interconnecting busbars. The interconnecting busbars are placed on the AmpliPHI Batteries' terminals first, then the flat washer, lock washer, and nut are secured to the terminal posts.

Figure 9.0 – Interconnecting Busbar Wiring onto AmpliPHI Threaded Stud

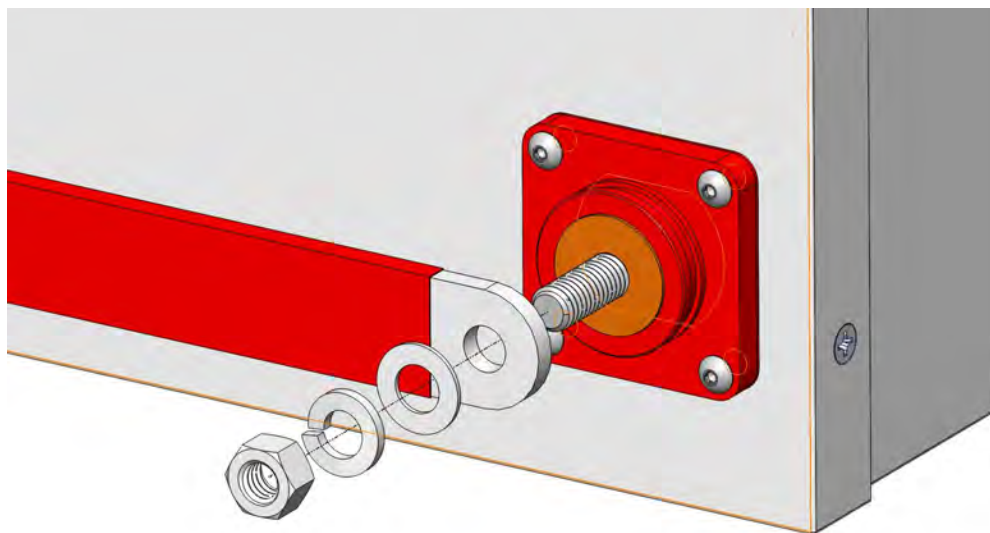

Helpful Tips:

- The interconnecting busbars’ ratings should match or exceed the AmpliPHI Battery bank’s total surge rating.
- Busbars for paralleling more than two or three AmpliPHI Batteries can be sourced [from](#) outside suppliers or custom ordered from SimpliPhi.
- SimpliPhi recommends paralleling AmpliPHI Batteries using interconnecting busbars (not battery cables) for AmpliPHI Battery Banks consisting of more than 20 batteries for a cleaner installation.
- Best practice involves wiring the battery leads to opposite ends of the busbars.
- Size the battery cables leading from the interconnecting busbars to the Balance of System equipment using the National Electrical Code’s Conductor Ampacity tables.



CAUTION: Do not reverse polarity. Use a voltmeter to check polarity before making connections to the battery terminals. Reversing polarity will Void the Warranty.

4.7 – Communications Wiring



CAUTION: The maximum number of AmpliPHI batteries that can be installed within a single bank is 40.

Each AmpliPHI battery includes three RJ45 ports, compatible with CAT5 (or greater) cable. Two of these ports are used for connecting between the AmpliPHI batteries in a battery bank (“daisy-chaining”). These two ports can be identified as the “daisy-chaining” ports because they are in close proximity to one another. The third port is used for the communications connection between the AmpliPHI battery bank and the inverter. **Only one of the AmpliPHI batteries within the battery bank will utilize this third port (either the battery at the head or the tail of the daisy-chain).** AmpliPHI batteries with un-utilized third ports may plug those ports using the RJ45 dust caps provided with the battery.

Figure 10.0 – AmpliPHI Networking Connection Ports

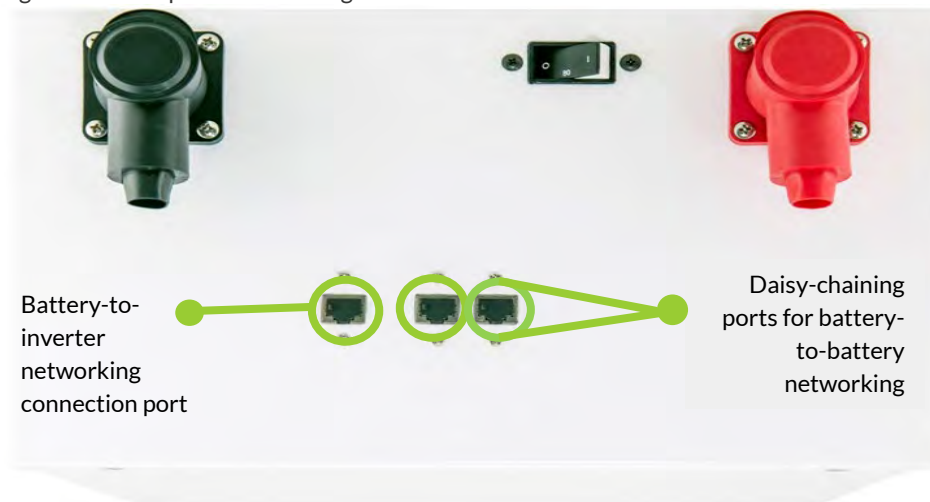

In a string of batteries, the two batteries at the ends of the communication chain will have a cable occupying only one of the “daisy-chaining” ports in the AmpliPHI battery. On each of these two batteries, the communication port not occupied by a cable will need a 120Ohm terminator plug installed in the open port (see photo). One terminator plug is included per AmpliPHI battery.

Figure 11.0 – AmpliPHI Batteries Networked Together in a Daisy-Chain

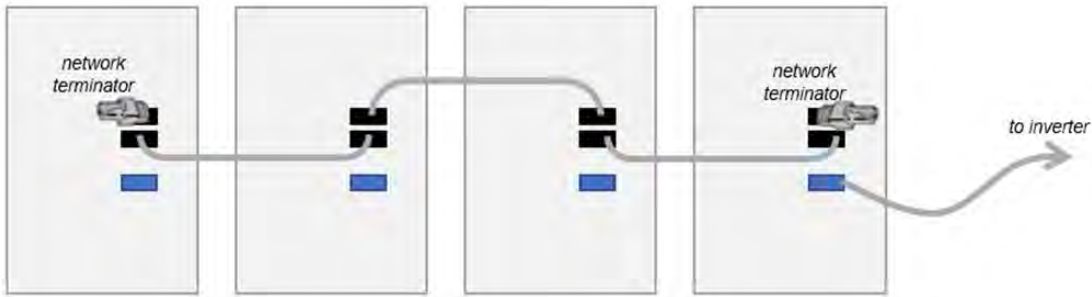

Figure 12.0 – AmpliPHI Batteries Networked

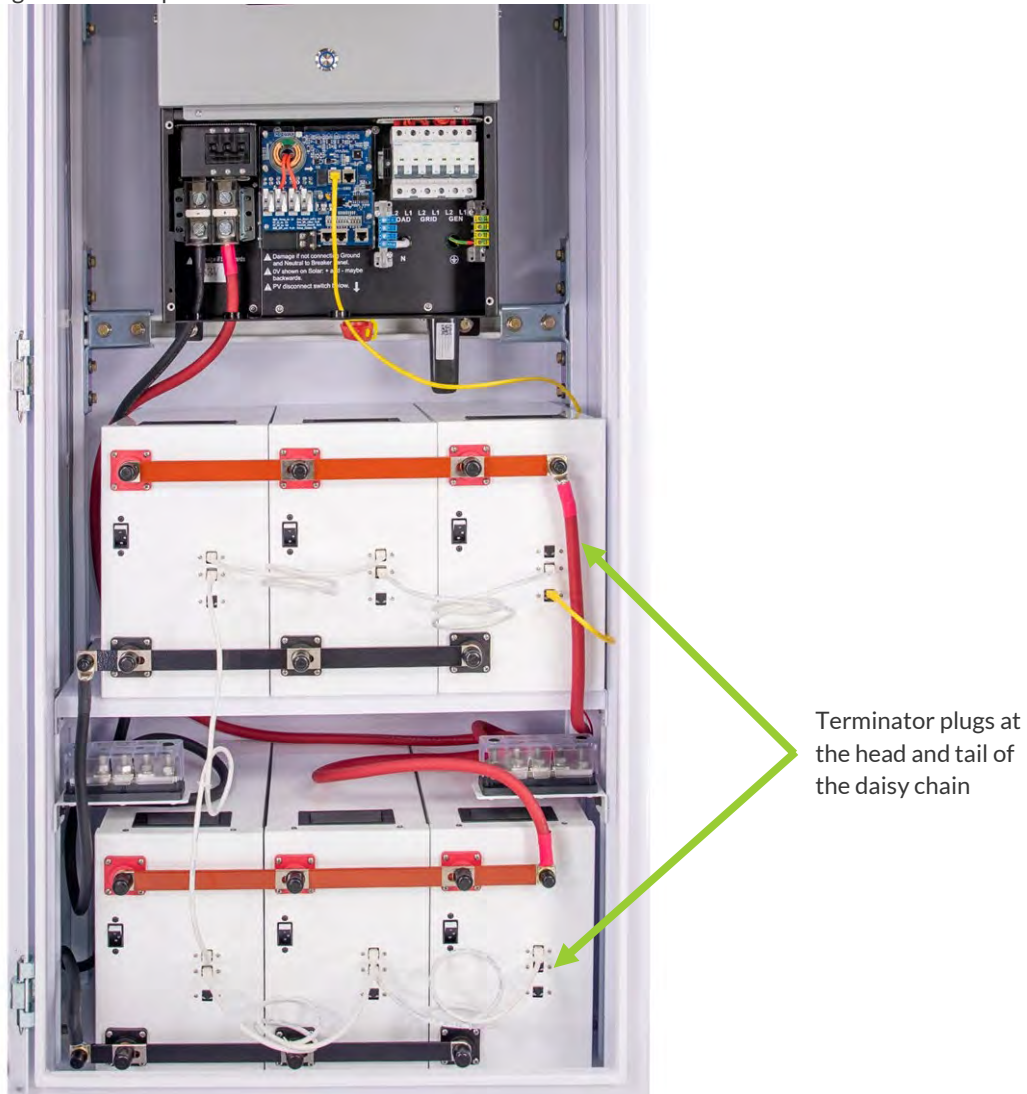
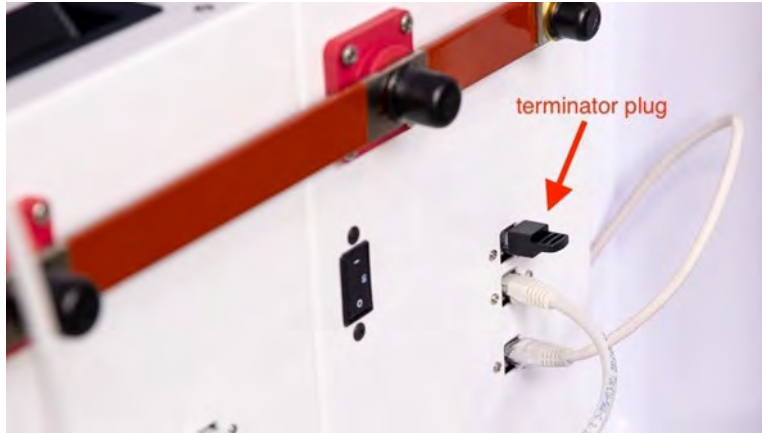

Figure 13.0 – AmpliPHI Battery’s Terminator Plug



The maximum number of AmpliPHI batteries that can be connected in a single system is 40, with a maximum total connected distance of 40m (131 feet) from the first AmpliPHI battery module to the last AmpliPHI battery module. While one 4’ CAT5 networking cable is provided per AmpliPHI battery, shorter networking cable for daisy-chaining the batteries may be used.

Utilizing the last/closest battery to the inverter, create the closed loop communications bridge between the AmpliPHI Battery and the Communication Input Port in compatible equipment utilizing CAT5 or greater cable. The cable length from the last AmpliPHI Battery to the Inverter cannot exceed 40m (131 feet).

4.8 – Battery System Commissioning



CAUTION: AmpliPHI Batteries should be installed, wired and commissioned by a qualified installer or professional electrician who is familiar with general electrical safety precautions and specific regional code requirements.

If the AmpliPHI Battery’s voltage has dropped (during an extended period in storage) to a voltage below the inverter’s minimum starting voltage requirement, then the battery will need to be charged using a plug-in / external charger. SimpliPhi’s batteries have a very low self-discharge rate and typically do not require ancillary charging. If the AmpliPHI Battery’s voltage has dropped due to over-discharge, try the steps outlined in Section 6.0 – Troubleshooting prior to using ancillary charging equipment.



CAUTION: Only use a SimpliPhi approved LFP charger if ancillary charging is required before installation, testing or troubleshooting. Failure to use a SimpliPhi approved LFP charger will damage the AmpliPHI Batteries and Void the Warranty. See Appendix C for more details on approved chargers.

1. Before installing the AmpliPHI Battery, inspect the battery for any signs of damage. Do not install or operate the battery if it has been damaged during shipping.
2. Prepare the battery module for installation by removing its plastic terminal covers, 11/16” stainless steel hex nuts and 3/8” lock washers from the battery terminals and set aside.



CAUTION: Do not attempt to loosen the large brass nut at the base of the terminals; doing so will damage the AmpliPhi battery and Void the Warranty.

3. Before installing the AmpliPhi Battery, test its voltage by turning its built-in breaker to the ON (I) position.
4. Measure the AmpliPhi Battery's voltage with a multimeter. Batteries *typically* ship at ~52 VDC.
5. When installing more than one AmpliPhi Battery, check that the batteries' voltage readings are similar. Batteries with a voltage variance greater than 1 Volt DC should be isolated and charged separately.
6. After testing the AmpliPhi Battery's voltage, turn the battery's built-in circuit breaker back to the OFF (O) position.
7. **Wire the AmpliPhi Battery bank with all the included AmpliPhi Batteries' built-in breakers in the OFF (O) position. All electrical wiring must be in accordance with Section 4.6 – Electrical Wiring and all communications wiring must be in accordance with Section 4.7 – Communications Wiring.**



CAUTION: All SimpliPhi Power Battery products are designed to work exclusively in parallel. Never connect in series to achieve higher voltages. Wiring in series will destroy the batteries and Void the Warranty.

Verify polarity at all connections before energizing system. Reverse polarity at the AmpliPhi Battery terminals will destroy the AmpliPhi batteries and Void the Warranty.

8. Confirm all loads are turned OFF. Disconnect the inverter's AC Output breaker or turn off the breaker at the top of your loads' breaker panel.
9. The main DC disconnect in the inverter's power panel should still be in the OFF position.
10. Turn all battery circuit breaker switches to the ON (I) position and wait 20 seconds for the BMS to re-boot.
11. Turn the main DC disconnect in the inverter's power panel ON.
12. At this point, the inverter may come on automatically in standby mode, or the inverter might need to be manually turned on.
13. Activate the AmpliPhi Battery's networking connection within the Balance of System (BoS) equipment. Then program the equipment for those settings that are not automatically communicated by the AmpliPhi to the BoS equipment. SimpliPhi's settings are specified in the relevant AmpliPhi Integration Guides specific to the inverter you are utilizing. (<https://simpliphipower.com/product-documentation/>) and are generally outlined in Section 5.0 – Programming of this Manual.



CAUTION: SimpliPhi Batteries must operate in conjunction with properly programmed Balance of System equipment. Operating the batteries with equipment that has not been programmed to SimpliPhi's specified parameters will damage the AmpliPhi batteries and Void the Warranty.



CAUTION: Charge the batteries fully. When first commissioning the battery system, the batteries must be charged fully before connecting any loads. Neglecting to charge the batteries fully when first commissioning the battery system will Void the Warranty.



CAUTION: Remember that charging the batteries in sub-freezing conditions will Void the Warranty.

14. Battery charging may be accomplished via the inverter/charger using an AC power source such as the grid or a generator, or via a charge controller using power from a connected solar PV array.
15. Battery charging may be accomplished via the inverter/charger using an AC power source such as the grid or a generator, or via a charge controller using power from a connected solar PV array.
16. The batteries will bulk charge to 56 VDC, will Absorb for 0.6 hours, and will then rest at approximately 53.3 VDC. At this point in the charging cycle, these voltages (53.3V) are considered 100% SOC.
17. Once the batteries are fully charged, turn on the inverter's AC Output breaker and/or the breaker at the top of your loads' breaker panel.

4.9 – Battery Bank Expansion

New SimpliPhi Batteries that are added to an existing SimpliPhi battery bank must be of the same nameplate voltage, form factor, and model.



CAUTION: Do not combine PHI Batteries with other brands or chemistries. This will Void the Warranty.

The following are instructions for expanding upon an AmpliPHI battery bank using AmpliPHI batteries.

In addition to adhering to all other Installation Manual instructions, refer to the following guidelines when expanding upon an existing AmpliPHI battery bank:

1. Charge the existing battery bank ("Bank A") according to normal charging procedure (AmpliPHI batteries charge to 56V and "rest" at approximately 52.5 - 53.5V after being taken off a charge).
2. Disconnect Bank A from the system, by either
 - a. Disconnecting all battery cables leading from Bank A's batteries to the battery combiner box, panelboard, or inverter's power panel, OR
 - b. Turning off the built-in breakers included in each of Bank A's batteries
3. Connect the additional batteries (Bank B) to the system, following all wiring instructions and torque specifications outlined in previous sections of segment 4.0 in this manual.
4. Check that the connected Balance of System (BoS) equipment settings (including charge rate) are altered as a result of being networked to Bank B.
5. Charge Bank B fully, making sure all loads are disconnected at the time of initial charge.
6. Wire all Bank A batteries and Bank B batteries in parallel, adhering to the wiring methods outlined in Sections 4.6 and 4.7 above.
 - a. Ensure that DC Positive common bus and DC Negative common bus ratings are appropriate for the new larger quantity of batteries in the bank.
 - b. Remember to re-orient the networking connections as one long "daisy-chain" for the expanded battery bank. This will involve unplugging the last terminator plug in the chain

and reposition to the end of the “daisy-chain” and reconnecting the battery-to-inverter communications cable and reviewing all BoS equipment settings for accuracy.

- Review all BoS equipment settings for accuracy; new values for certain settings should automatically appear as reflective of the larger, expanded battery bank.

5.0 – Programming

5.1 – Operating Parameters per Warranty

To maintain AmpliPHI Battery health and to comply with the Warranty, adhere to the operating parameters outlined in Tables 4.0 and 5.0 below. Refer to the manufacturer-specific Integration Guide from SimpliPhi’s Product Documentation web page for a complete list of settings specific for the inverter that you are pairing with: <https://simpliphipower.com/product-documentation/>.

Table 4.0 – Operation Parameters

Recommended Operating Conditions for 10 Year Warranty			
Depth of Discharge (DoD)	80% (~10,000 cycles)	90% (~5,000 cycles)	100% (~3,500 cycles)
Operating Temperature °F (°C)	32 to 120 (0 to 49) / Optimal 77 to 95 (25 to 35) <i>internal battery temperature</i>		
Low Battery Cut-Off Voltage (V) ³	50.2	49.6	48
Absorb / High Cut-Off Voltage (V)	56		
Absorb Time	0.1 Hours		
Absorb End Amps (if applicable)	2% of the PHI Battery bank’s total Ah capacity		

Table 5.0 – Operating Limitations

Notes / Operating Limitations for AmpliPHI Batteries	
	AmpliPHI 3.8
Limitations by Model	48V
Continuous Discharge Rate (ADC)	37.5
Surge Discharge Rate (ADC) – 10 minutes maximum	100
Continuous Charge Rate (ADC)	37.5

- Levels are typically @ 25°C and may need adjusting at temperature extremes.
- When performing rapid deep charge/discharge cycles, the batteries should be allowed to "rest" in between.



CAUTION: When commissioning the system, the appropriate controller and inverter settings must be programmed per the manufacturer’s recommendations. Consult the manufacturer’s manuals and/or the Integration Guides listed on [SimpliPhi’s Product Documentation web page](#). Failing to do so will damage the AmpliPHI batteries and will Void the Warranty. The following Charge Controller Integration tables are for general reference only.

6.0 – Troubleshooting

Certain AmpliPHI BMS fault trip conditions (outlined in Section 1.3.1 and Table 1.0 of this Manual) result in the need for a manual re-set of your AmpliPHI Battery's internal BMS. If a fault has occurred, consult SimpliPhi Technical Support (TechSupport@SimpliPhiPower.com) to ensure that your AmpliPHI Battery bank has been sized correctly and inhabits operational conditions.

Once the fault's cause has been addressed with Support, take the following steps to re-set the BMS:

The PHI batteries are reading extremely low or no voltage:

1. If the breakers are not all off already, turn off each of the built-in breakers in all of the AmpliPHI Batteries in the battery bank.
2. Turn off the main DC disconnect located in the inverter's power panel, between the battery bank and the inverter.
3. Turn off the main breaker at the top of the inverter's AC distribution panel or sub-panel.
4. **Wait 5 minutes**, for the BMS in each battery to re-set itself.
5. Use a multi meter to take voltage measurements of each AmpliPHI battery in the battery bank, to make sure the voltage increased to the minimum voltage necessary for the inverter to turn on.
To measure a single battery's voltage within a battery bank, only the battery being measured has its built-in breaker in the ON (I) position; all other batteries in the bank must have their built-in breakers OFF (O).
6. Turn on each of the built-in breakers in all of the AmpliPHI Batteries in the battery bank and **wait 20 seconds** for the BMS to re-boot.
7. Turn on the main DC disconnect located in the inverter's power panel.
8. Check that all parameters in the Balance of System equipment are programmed according to the relevant SimpliPhi Integration Guide. Failure to do so will damage the PHI batteries and Void the Warranty.
9. To charge the batteries quickly, SimpliPhi recommends using an AC power source to immediately charge the PHI battery bank via the inverter's charger. However, the AmpliPHI batteries will not incur any damage if they are charged using a connected solar PV array via the charge controller. The important aspect of this step is that the batteries re-charge **as soon as the BMS has re-set**.
10. Turn on the inverter's AC Input breaker and turn on the inverter.
11. The inverter should automatically self-initiate a battery charge. However, a Force Charge may need to be initiated in the inverter.

Appendix A – AmpliPHI Battery Safety & Green Attributes, Certifications

This Appendix section covers the AmpliPHI Battery safety attributes and certifications, such as the lack of thermal runaway with fire propagation, off-gassing, UN DOT certification and UL compliance and certification. It also covers the AmpliPHI Battery's green attributes – from products to materials to disposal, as well as relevant environmental and ecological considerations.

A.1 – Safety Attributes and Certifications

A.1.1 – Intrinsically Safe Operation and Installation

The AmpliPHI Lithium Ferrous Phosphate (LFP) battery cell component is made with an intrinsically safe cathode material (iron phosphate). This creates a strong molecular bond, which withstands extreme conditions, prolongs cycle life, and maintains integrity with little or no maintenance over extended periods of time. There is virtually no danger of Thermal Runaway with fire propagation, as there may be with Lead Acid, NiCd, and Lithium Cobalt type batteries (NCA, NMC, LCO). No venting or cooling is required. No precautions or special structural considerations are necessary when installing AmpliPHI Batteries.

A.1.2 – No Safety Hazards due to Off-Gassing, Exposure to Acids, Thermal Runaway

AmpliPHI Batteries do not vent dangerous gasses during normal operation, such as hydrogen and oxygen, because chemicals contained in Lithium Ferro Phosphate cells' electrolyte do not electrolyze to any appreciable extent within the AmpliPHI Battery's operating voltage range. In contrast, lead acid batteries which contain water and sulfuric acid experience significant electrolysis into H₂ and O₂ during normal operation. There are no dangers of exposure to sulfuric acid because AmpliPHI Batteries do not have caustic electrolytes. Thermal runaway with fire propagation is not an issue with AmpliPHI products due to the basic nature of Lithium Ferro Phosphate cell chemistry utilized in all our power storage products.

A.1.3 – PHI Battery Control and Protective Circuitry

SimpliPhi Power Inc. utilizes balancing, voltage regulation, thermal and current controls, as well as other protective measures, in its AmpliPHI Battery Management System (BMS). This protective circuitry is embedded in the architecture of each AmpliPHI Battery.

A.1.4 – UN DOT Certified Cells

The Lithium Ferrous Phosphate (LFP) cells are independently certified to withstand the UN DOT 38.3 testing guidelines with no special circuitry added. These tests include short circuit, over-voltage, overcharging, extreme temperature, high altitudes, shock and extreme vibration testing.

A.1.5 – UL Compliance

The Lithium Ferrous Phosphate cells within the AmpliPHI Batteries fully comply with the safety testing parameters of UL 1642.

A.1.6 – RoHS Compliant

SimpliPhi Power 3.8 Batteries are RoHS compliant. Any RoHS compliant component is tested for the presence of Lead (Pb), Cadmium (Cd), Mercury (Hg), Hexavalent chromium (Hex-Cr), Polybrominated biphenyls (PBB), and Polybrominated diphenyl ethers (PBDE). For Cadmium and Hexavalent chromium, there must be less than 0.01% of the substance by weight at raw homogeneous materials levels. For Lead, PBB, and PBDE, there must

be no more than 0.1% of the material, when calculated by weight at raw homogeneous materials. Any RoHS compliant component must have 100 ppm or less of mercury and the mercury must not have been intentionally added to the component. In the EU, some military and medical equipment are exempt from RoHS compliance.

A.2 – Green Attributes, Environmental & Ecological Considerations

A.2.1 – Materials

The primary materials (lithium, iron, phosphate) that make up AmpliPHI Batteries are environmentally benign and pose very few polluting or environmentally degrading by-products in the harvesting and refinement processes. This is especially true when compared to those of lead acid, NMC, NCA, LCO, NiCad, and NiMH batteries.

A.2.2 – By Products

There are no toxic by-products associated with the manufacturing or use of AmpliPHI Batteries, such as off-gassing hydrogen, sulfuric acid spillage, lead contamination, or explosive chemicals.

A.2.3 – Operation

There is no need for maintenance, such as adding water or chemicals, nor is there corrosion of terminals or containment facilities, or dispersion of fumes as with other battery types. Once installed, AmpliPHI Batteries are maintenance free as long as all the Installation Manual, Integration Guidelines and Warranty requirements are adhered to.

A.2.4 – Life Cycles

AmpliPHI Batteries are designed for thousands of cycles while maintaining 80 percent or more of their initial capacity. To achieve this, it is critical to follow the operating conditions outlined in our manuals.

A.2.5 – Disposal

AmpliPHI products are non-hazardous, may be disposed of without damage to the ecosystem, and returned to the earth, while easily recombining with the elements without harmful by-products. The outer casing and brackets contain steel, aluminum, copper, cardboard, and recyclable plastic. Lithium Ferrous Phosphate (LFP) materials can also be recycled through established battery centers if desired.

A.2.6 – Lithium Ferrous Phosphate Batteries and the Environment

As the use of this battery chemistry in larger batteries becomes more common, questions of sustainability and environmental impact inevitably arise. Of the lithium ferrous phosphate chemistries being considered for large format batteries, SimpliPhi Power believes that batteries based on our proprietary lithium ferrous phosphate chemistry and circuitry offer a clear advantage, not only over alternate Li-ion chemistries (lithium cobalt oxide), but all battery chemistries that are currently commercially available. This belief is based on the minimal environmental impact associated with the manufacturing of AmpliPHI and PHI Batteries, the extended cycle life and the significantly smaller end-of-life footprint that results from the use of AmpliPHI and PHI Batteries.

A.3 – Summary

The Lithium Ferrous Phosphate (LFP) cells utilized throughout the entire AmpliPHI, PHI and LibertyPak product lines are classified as non-hazardous by OSHA and WHMIS. They are non-toxic, unlike NMC, NCA, LCO, NiMH, NiCad or Lead Acid types of batteries (including AGM). SimpliPhi Batteries contain the least amount of toxic metals and are the most eco-friendly of all common battery types. Lithium easily combines into harmless compounds when disposed of. SimpliPhi Batteries are the least polluting rechargeable batteries on

the market today – no fumes, leaking, or gas discharge and no chemicals or acids to worry about. Designed and Manufactured in the USA Using Exclusive American Patented Technologies.

Appendix B – AmpliPHI Approved External Chargers

This Appendix section covers the AmpliPHI Battery's approved external / plug-in chargers. Typically, ancillary charging of SimpliPhi's batteries **is not required**, and charging using any of the charge controllers and/or inverter/chargers listed in the "Integration Guides" section of the SimpliPhi web site's [Product Documentation](#) page is acceptable. However, ancillary charging may be necessary in the following situations:

1. No charge controller or inverter/charger is available
2. Increasing the battery's State of Charge (SoC) after an extended storage period and prior to installation
3. For recharge purposes when the battery's voltage is below the minimum required voltage for charge controller and/or inverter/charger equipment to turn on

B.1 – Recommended 48V Charger

The 54.6V 4A 13 Series 48V LiFePO₄ Smart Charger from WAOUKS is recommended and available online for purchase [at this link](#).

The 58.4V 5A 16 Series 48V LiFePO₄ Smart Charger from WAOUKS is recommended and available online for purchase [at this link](#).

The 48V/30A for LiFePO₄ / LiFeYPO₄ (58.8V) + GMS charger from GWL/Power is recommended and available for online purchase [at this link](#).

The Smart Charger (15A) for 51.2V (16 cells) LiFePO₄ Battery Pack – CH-PFC51215A charger from AA Portable Power Corp is available online for purchase [at this link](#).

When placing your order, specify the connection type to match your battery model. PHI 3.8 batteries require a charger with alligator clips or crocodile clips.

B.2 – Alternative Chargers

If the above listed chargers are unavailable or undeliverable to your specific location, SimpliPhi also approves of Iota Engineering's battery chargers ([link here](#)) to increase the AmpliPHI battery's voltage. These chargers should only be used in order to increase battery voltage enough to regain system operability; these chargers should not be used to regularly and fully charge the AmpliPHI battery.