



Installation and Safety Manual

for the

c-Si M60 NA 30119 Family of Crystalline Photovoltaic Modules

Table of Contents

1. INTRODUCTION.....	4
A. Disclaimer of Liability	4
2. SAFETY INFORMATION.....	4
A. General Considerations	4
B. Installation Precautions	5
C. Electrical and Optical Safety	6
D. Fire Safety.....	6
3. MODULE PERFORMANCE AND SAFETY STANDARDS.....	7
A. Standard Test Conditions.....	7
B. Underwriters Laboratories Information	7
C. National Electrical Code (NEC)	7
4. LOCATION OF SOLAR MODULES.....	7
A. Orientation, Tilt Angle, Shading, & Performance.....	7
5. BOSCH SOLAR ENERGY MODULE CHARACTERISTICS	8
A. Electrical Characteristics	8
B. Thermal Characteristics	8
C. Bypass diodes.....	9
D. Mechanical Specifications.....	9
6. MECHANICAL INSTALLATION	10
A. Module Orientation and Handling Safety	10
B. Wind and Snow Loads	11
C. Mounting Methods.....	11
D. Bolting Mounting Method Example	11
7. ELECTRICAL INTERCONNECTIONS	12
A. Module To Module Interconnection	12
B. Grounding.....	14

8.	STORING, TRANSPORTING AND UNPACKING SOLAR MODULES.....	16
A.	Packaging.....	16
B.	Unpacking Instructions.....	17
C.	Safety Considerations.....	17
9.	PRODUCT SUPPORT	18
10.	CARE AND MAINTENANCE	18
A.	Module Cleaning	18
B.	Inspection and Repair	18
11.	END OF LIFE	19

1. INTRODUCTION

Thank you for purchasing this Bosch Solar Energy product. In 2011, the Bosch Group proudly celebrated its 125 year anniversary, symbolizing the company's long-term viability and continued commitment to bringing "Invented for Life" solutions to market. Bosch Solar Energy is the photovoltaic business operation within the Bosch Group and manufactures high-quality solar modules. Our solar modules utilize advanced technology components to supply environmentally friendly solar energy for many years when correctly installed and operated. This document provides recommendations for the installation and maintenance of Bosch Solar Energy's crystalline silicon photovoltaic (PV) modules and also identifies the hazards associated with the handling and installation of these products.

Before installing, wiring and using a Bosch Solar Energy module, it is important to thoroughly read this manual and understand the instructions. Installers must understand the basic principles of electricity and electrical apparatuses as well as article 690 of the National Electrical Code. Please pay special attention to any safety instructions designated with the following caution symbol:

 **CAUTION:**

A. Disclaimer of Liability

Since the use of this Installation and Safety Manual and the conditions or methods of installation, operation, use and maintenance of the module are beyond the control of Bosch Solar Energy, Bosch Solar Energy does not assume responsibility and expressly disclaims liability for loss, damage injury or expense arising out of or in any way connected with such installation operation, use or maintenance of the module.

Bosch Solar Energy assumes no responsibility for infringement of patents or other rights of third parties which may result from use of the module. No license is granted by implication or otherwise under any patent or patent rights. The information in this Manual is based on Bosch Solar Energy's knowledge and experience and is believed to be reliable; but such information including product specifications (without limitations) and suggestions do not constitute a warranty, expressed or implied. Bosch Solar Energy reserves the right to make changes to the product, specification or this Manual without prior notice.

2. SAFETY INFORMATION

A. General Considerations

Bosch Solar Energy modules should only be installed by qualified installers with adequate solar PV installation experience.

Take note of all relevant laws, regulations, guidelines and safety measures when handling solar photovoltaic modules.

Prevent accidents such as electric shocks during the installation, operation, maintenance and disposal of solar modules by taking the appropriate precautions.

Keep unauthorized persons and animals away from solar energy systems. Pay particular attention to children.

Take special note of occupational safety and accident prevention regulations applicable to the work in question.

Bosch Solar modules can be combined with other components to form a photovoltaic system. In this case you must also follow the installation and operation instructions issued for these additional components.

You must comply with the standards and regulations applicable to PV installations, such as the National Electrical Code (NEC) and local safety and building codes, the grid operator's technical connection requirements, and trade association rules concerning accident prevention. Failure to comply can lead to significant personal injury and equipment damage.

B. Installation Precautions

Use appropriate protective safety equipment as recommended by local safety codes and practices (e.g., hard hat, scaffolding, steel toe shoes, gloves and restraining harness) and exercise caution particularly when installing modules at height (e.g. on a roof). Solar modules are heavy and should always be handled by two people.



CAUTION: Always adhere to the following installation precautions:

- **ALWAYS** handle solar modules by their long sides and keep sharp objects away from the module surface when handling.
- **DO NOT** place heavy loads or drop objects on the module
- **DO NOT** install a solar module in which the backsheet has been damaged
- **DO NOT** walk on, bend or drop the solar module
- **DO NOT** attempt any installation in adverse weather conditions (high winds, rain or when ice or snow is present)
- **NEVER** leave a module unsupported or unsecured. If a module falls, the glass could break. A module with broken glass cannot be repaired and must not be used.
- **NEVER** attempt to modify a solar module or take it apart. Never remove any markings or labels applied or parts fitted by the manufacturer. Do not apply any paint or adhesive to a solar module
- **DO NOT** attempt to install or service any portion of the PV system unless you understand the electrical operation and are fully qualified to do so.
- **DO NOT** drill holes in the frame or glass of the module. Doing so will void the warranty.
- Have a fire extinguisher, and first aid kit when performing field work on all energized equipment where the system open circuit voltage is 30 volts or greater.
- Since sparks may be produced, do not install module where flammable gases or vapors are present
- **DO NOT** work on modules when they are wet. If a wet module is cracked or broken the full system voltage may be present.
- **ALWAYS** mount the solar module so that the junction box is at the upper edge of the module
- Ensure that all electrical connections are properly connected and protect them from interference from unauthorized personnel or animals

C. Electrical and Optical Safety

Photovoltaic (PV) modules generate electricity whenever they are exposed to light. Lethal voltages and/or a shock hazard may be present in photovoltaic modules and arrays even during sunlight hours and even at low light levels. This hazard increases when multiple modules are connected together to provide higher system voltage or current levels. Dangerous voltages may also be present at night from connections to batteries and feedback from inverters or other system components.

Cover the front surface of the modules with an opaque material to prevent the modules from generating electricity. Ensure that both the front and back surfaces of the module and the sheaths of the connecting cables are undamaged.

Improper electrical connections can result in electrical arcing which can ignite any flammable material located in close proximity. When flammable material is within 30 cm (12 in.) of either the solar module or any of the electrical connections then install an appropriate flame barrier to prevent potential risks of fire.



CAUTION: Always adhere to the following installation precautions:

- **DO NOT** damage, pull, bend or place heavy loads on the cables
- **DO NOT** connect the cables if the terminals are wet
- **DO NOT** disconnect module cables under electrical load
- **DO NOT** attempt to open the diode housing or junction box located on the back side of any Bosch Solar Energy module. There are no user serviceable parts inside. Opening the junction box may expose the individual to an electrical shock hazard and will void the warranty.
- Remove any jewellery or other metallic adornments to avoid accidental electrical contact and use insulated tools
- A two-person team is to be used while performing field work on all energized equipment where the system open circuit voltage is 30 volts or greater.
- Wear electrical insulating gloves rated at 1000 volts and suitable eye protection when working on systems where the system open circuit voltage is 30 volts or greater.
- **DO NOT** touch terminals while the module is exposed to light without wearing electrical insulating gloves.
- **DO NOT** connect or disconnect a module unless the array string is open-circuited or all of the modules in the string are covered.
- Prevent sunlight from being concentrated or reflected artificially onto a solar module. In particular, do not use any concentrating lenses or mirrors.

D. Fire Safety

The Bosch Solar Energy c-Si M60 NA 30119 modules have been certified by Underwriters Laboratories to comply with UL1703 Class C fire rating. To satisfy the conditions of this rating when installing on a building, you must mount the modules using standoff or rack methods over a fire resistant roof covering rated for the application. The module listing may not apply if the modules are mounted integral to the roof or wall of a building, and does not cover marine or vehicle applications. Refer to your local authority for guidelines and requirements of building or structural fire safety.

3. MODULE PERFORMANCE AND SAFETY STANDARDS

A. Standard Test Conditions

The module electrical ratings at Standard Test Conditions appear on the label on the back of each module. Standard Test Conditions are defined as an irradiance level of 1000W/m^2 , AM 1.5 spectrum and a cell temperature of 25°C (77°F). It is important to note that, under normal operating conditions, a photovoltaic module is likely to experience conditions that produce more current and/or voltage than reported at Standard Test Conditions.

B. Underwriters Laboratories Information

These Bosch Solar Energy modules are listed to UL 1703, the Standard for Safety for Flat-Plate Photovoltaic Modules and Panels. This Standard covers solar PV modules intended for installation on or integral with buildings or to be freestanding (not attached to buildings), in accordance with the National Electrical Code (NFPA 70), appropriate building codes, and any other applicable local codes in the US.

C. National Electrical Code (NEC)

The National Electrical Code (NEC) covers the installation of photovoltaic systems and must be adhered to when systems are designed and installed. Article 690, Solar Photovoltaic Systems, of the NEC applies to solar photovoltaic energy systems including the array circuit(s), power conditioning unit(s) and controller(s) for such systems.

Under normal conditions, a photovoltaic module is likely to experience conditions that produce more current and/or voltage than reported at Standard Test Conditions. As previously mentioned, the values of I_{sc} and V_{oc} marked on the modules must be sized according to section 690-8 of the National Electrical Code. All wiring shall be in accordance with the NEC, and grounding method of the module arrays shall comply with the NEC, Article 250.

4. LOCATION OF SOLAR MODULES

A. Orientation, Tilt Angle, Shading, & Performance

Photovoltaic modules generate maximum power when facing directly towards the sun. PV systems can track the sun or remain in a fixed tilt position. Tracking systems will produce more energy on an annual basis but are more costly and may require more maintenance. Most PV systems are designed with a fixed tilt. The further North from the equator, the greater the tilt angle required. Since applications vary widely, be sure to consult a PV system integrator or use a commercially available software program to determine the expected system energy output. The following chart may serve as a rule of thumb.

Site Latitude	Horizontal Tilt Angle
0-10	= 10 Degrees
11-20	= Latitude
21-30	= Latitude + 5~
31-40	= Latitude + 10~
41+	= Latitude + 15~

In order to minimize module soiling, it is not recommended to set the tilt angle below 10 degrees. Dirt tends to accumulate on modules installed at lower angles and does not wash off as readily during rainfall. Dirt accumulation, debris and even snowfall on the module will reduce its energy output.

Select a location with the best possible solar radiation for the photovoltaic system you want to install. Your choice of location should take into account the seasonal changes in light conditions. Modules should be located in areas with an unobstructed view of the sun where they will receive maximum exposure of sunlight for the longest possible time during the day. Shadowing caused by buildings, roof pipes and vents, trees, utility poles and other obstructions may significantly reduce the module energy output.

In systems that are configured with multiple rows of modules, the rows must be spaced far enough apart to minimize the impact of shading on other rows. This distance is dependent on the latitude and tilt angle at which the system is installed. The closer to the equator, requires a lower tilt angle and therefore the shorter this distance. The further from the equator, higher tilt angle and therefore the greater this distance needs to be. If there are questions regarding the optimum configuration in which to arrange, mount or wire the modules, obtain assistance from your Bosch Solar Energy dealer or distributor or retain the services of an engineer familiar with the proper design of PV systems.

5. BOSCH SOLAR ENERGY MODULE CHARACTERISTICS

A. Electrical Characteristics

The following electrical characteristics were measured under Standard Test Condition (STC):

Electrical Characteristic	Measure	c-Si M60 NA 30119			
Model Designator (Part No. Suffix)	--	240Wp	245Wp	250Wp	255Wp
Maximum Power (Pmax)	Watts	240	245	250	255
Open Circuit Voltage (Voc)	Volts	37.07	37.27	37.47	37.67
Short Circuit Voltage (Isc)	Amps	8.51	8.61	8.71	8.81
Maximum Power Voltage (Vmpp)	Volts	30.16	30.36	30.56	30.79
Maximum Power Current (Impp)	Amps	7.98	8.08	8.18	8.28
Maximum System Voltage	Volts	600			
Maximum reverse current protection	Amps	17			

Please note the following: the electrical characteristics are within ± 10 percent of the indicated values of Isc, Voc, and Pmax under Standard Test Conditions (i.e. irradiance of $1000\text{W} / \text{m}^2$, AM 1.5 spectrum, and a cell temperature of 25°C (77°F)).

B. Thermal Characteristics

Thermal Characteristic	Measure	c-Si M60 NA 30119			
Model Designator (Part No. Suffix)	--	240Wp	245Wp	250Wp	255Wp
Operating Temperature Range	$^\circ\text{C}$	-40 to 85			
Temp. Coefficient of Maximum Power	$\% / ^\circ\text{C}$	-0.429			
Temp. Coefficient of Open Circuit Voltage	$\% / ^\circ\text{C}$	-0.321			
Temp. Coefficient of Short Circuit Voltage	$\% / ^\circ\text{C}$	+0.067			

C. Bypass diodes

All modules are equipped with factory installed bypass diodes in the junction box (see table below). The use of bypass diodes reduces the risk of heating of the shaded cells, limiting the current that can pass through them and thereby avoiding damage to the cells.

Maximum Reverse Voltage	Average Rectified Forward Current	No. Diodes per Module	Total No. of Cells per Diode
45V	15A	3	20

⚠ CAUTION: DO NOT attempt to open the diode housing or junction box located on the back side of the module. There are no user serviceable parts inside. Opening the junction box may expose the individual to an electrical shock hazard and will void the warranty.

D. Mechanical Specifications

The Bosch Solar Energy module dimensions are summarized in the table below.

Mechanical Characteristic	c-Si M60 NA 30119			
Model Designator (Part No. Suffix)	240Wp	245Wp	250Wp	255Wp
Dimensions in inches (L x W x H)	64.96 x 38.98 x 1.65			
Dimensions in mm (L x W x H)	1,650.0 x 990.0 x 42.0			
Weight in pounds	41.89 +/- 2.2			
Weight in kilograms	19.0 +/- 1			

Figures 5A, 5B and 5C provide illustrations of the module mounting holes, frame design and general dimensions follow below. Please note that all units are in millimeters.

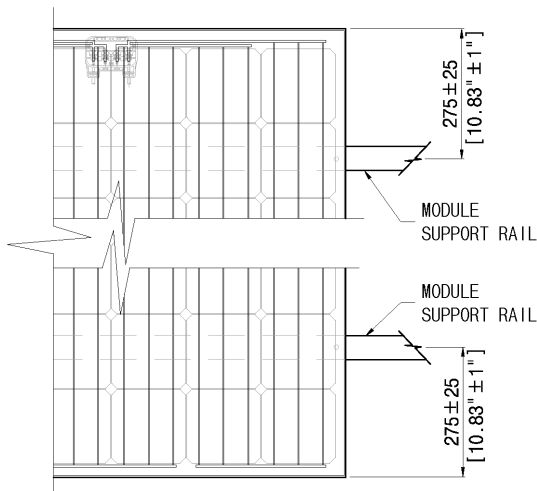

Figure 5A: Module Mounting Hole Locations

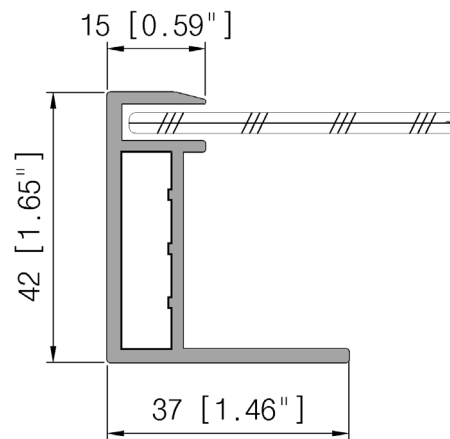

Figure 5B: Frame Side View

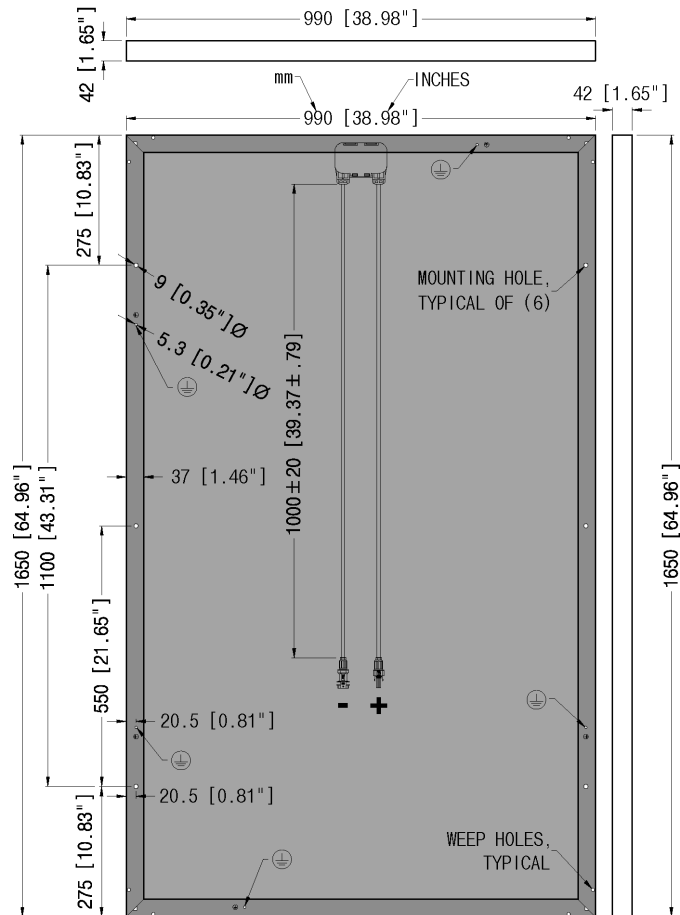

Figure 5C: Module dimensions

6. MECHANICAL INSTALLATION

A photovoltaic system must be installed so that it can withstand environmental influences such as wind, rain, hail, and snow. If solar modules are to be installed on a roof or façade, a suitable mounting system will be required to enable the solar modules to be properly fastened. Make sure that the mounting system structure and all components used for fastening the solar modules in place comply with all relevant local building codes and regulations.

CAUTION:

The information in this section only suggests possible methods of securing the PV modules to a 'module mounting system.' It is the sole responsibility of the user and/or installer to verify that the module mounting system and mounting method are properly engineered and in accordance with local building codes and regulations.

A. Module Orientation and Handling Safety

Bosch Solar Energy PV modules can be arranged in either landscape or portrait position on flat or sloped roofs or surfaces and at flat or tilted angles. Always use caution when mounting a module on tilted angles or sloped roofs so the module does not slide out of position while attaching it to the module mounting system. It is also recommended that modules are mounted so that the junction box shall be in the uppermost position to minimize the ingress of water. A clearance of 6mm / 0.25" between modules is sufficient in most installations to accommodate thermal expansion. However, the appropriate clearance is dependent upon installation specific factors including the module mounting system, ambient temperature at the site and the maximum

operating temperature of the module. Also it is important to note that the maximum distance between modules should not exceed 12” based on using standard wiring. The minimum recommended standoff distance between Bosch Solar Energy modules and the roof is 1.57 inches (40mm).

B. Wind and Snow Loads

All solar installations should also be in accordance with local building codes and regulations. For proper structural design, it is recommended to retain the services of a structural engineer experienced with the installations of PV systems. It is important to reference the most current revision of ASCE 7 for determining the proper wind and snow load calculations for the project site. Bosch Solar Energy modules have been evaluated by UL for a maximum positive or negative design loading of 50 lbs/ft² (2,400 Pa).

C. Mounting Methods

Bosch Solar Energy modules may be secured via a variety of traditional mounting methods including bolt and clamp styles. Contact Bosch Solar Energy if alternate methods of mounting are required. Regardless of mounting method employed, always thoroughly review and follow the instructions of the mounting structure manufacturer. To comply with the requirements of UL 1703 the modules must be fixed using hex-head bolts. For greater longevity, Bosch Solar Energy recommends that all fixings are made of 316 grade (A4) stainless steel (not supplied). Prevention of the corrosive effects of dissimilar metals must be considered when mounting the solar module frame (Aluminum) against other materials.

D. Bolting Mounting Method Example

Many installations utilize the traditional ‘bolting’ mounting method (i.e. fastening the module to the support structure via four (or sometimes six) mounting holes that are located on the mounting frame). The recommended installation method is as follows:

- 1) Secure the module to the structure using the factory mounting holes or along the module frame above the factory mounting holes (refer to Figure 6A)
- 2) A quantity of four ¼” (M6) stainless steel bolts with length less than ¾” (20 mm), with four ¼” (M6) stainless steel nuts, washers, and spring washers are recommended for mounting one module. (Figure. 6B).
- 3) The maximum mounting torque for the ¼” bolts should not exceed 12-15 ft-lbs or 9-10 N.m for a M6 bolt
- 4) Please refer to Figures 5A and 5C for the module dimensions and hole locations
- 5) Maintain a gap of least ¼” (6 mm) between neighboring modules.
- 6) When mounting multiple rows of PV modules be sure to maintain enough distance to prevent shading by adjacent rows.
- 7) Make sure to face the glass side of the module to the sun
- 8) **DO NOT** remove or alter the module frame. Creating additional mounting holes may damage the module and reduce the strength of the frame and will invalidate the warranty.

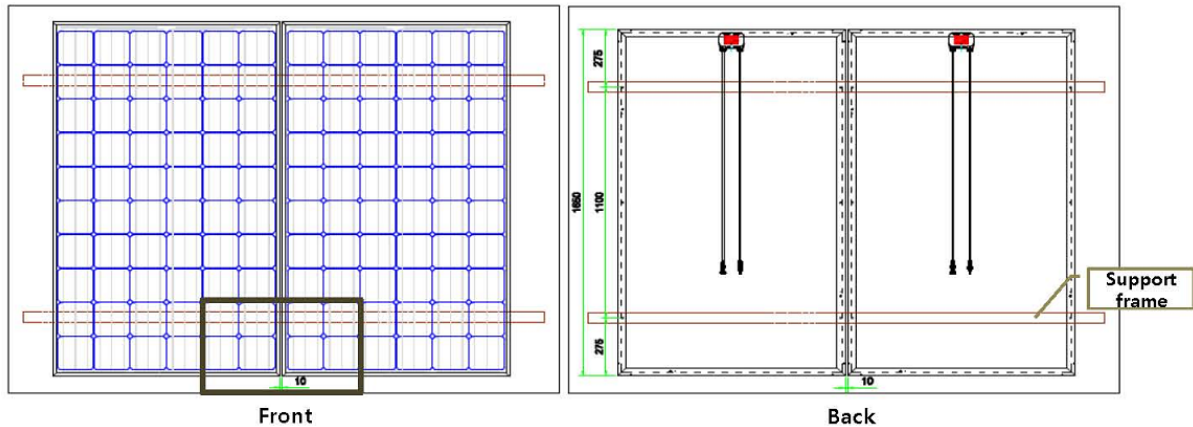

Figure 6A: Example Mounting Method

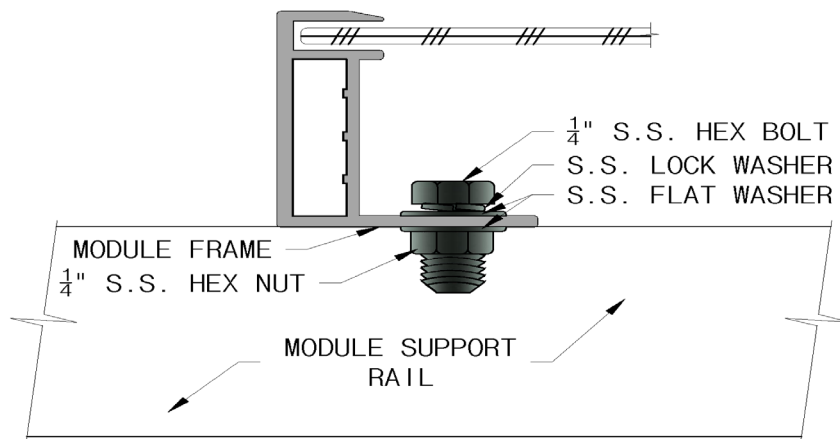

Figure 6B: Illustration of Mounting Hardware

The ‘clamp’ mounting style (i.e. using end clamps and mid clamps along the module frame for securing modules to the racking system) may also be utilized. It is recommended that the clamp be placed within +/- 1” (25 mm) of the centerline of the factory mounting hole.



CAUTION:

Contact Bosch Solar Energy if only the short frame edges are to be used for anchoring the module. This type of mounting method typically requires additional analysis by Bosch Solar Energy. Failure to do so may invalidate the warranty.

7. ELECTRICAL INTERCONNECTIONS

A. Module To Module Interconnection

Bosch Solar Energy modules have been designed to be easily interconnected. Each module comes with one positive (+) cable with a plug on one end and one negative (-) cable with a receptacle on one end. Both wires are connected inside of the junction box (diode housing).

See Figure 7A below for more information. Modules are interconnected by inserting the plug from one module into the receptacle of the next module in the array string. Secure the mated connector pair to the inside flange of the module frame to protect it from damage. For added safety, Bosch Solar Energy modules feature locking connectors that require a tool for disconnection.

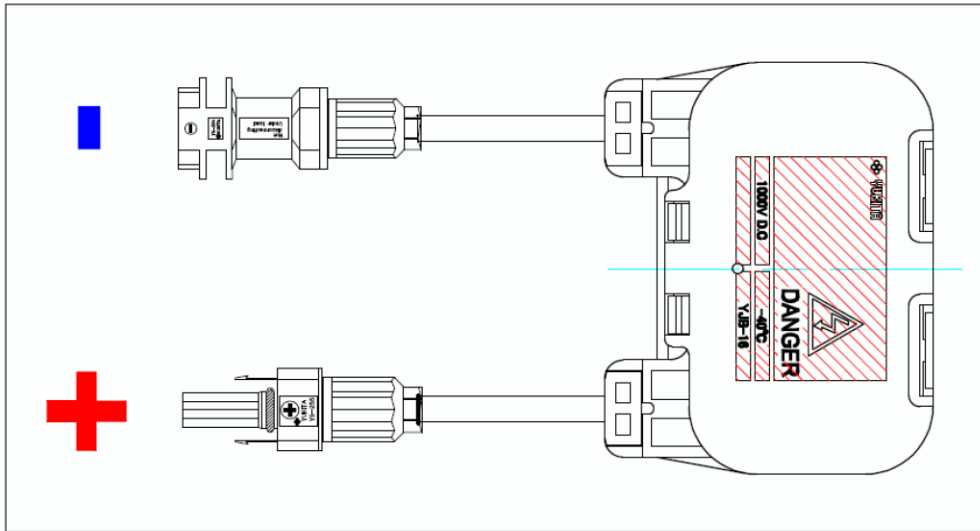

Figure 7A: Overview of Module Junction Box and Cables

Wiring Considerations

Always use cables and connection techniques consistent with the anticipated environmental conditions and applicable codes related to the installation. For wiring that is exposed to weather, select conductor cable that is sunlight (UV) resistance and that offers a minimum rating of 90 °C (194 °F). Bosch recommends that all wiring be double insulated, use flexible copper (Cu) conductors at least 3mm² in diameter (AWG 12) and rated as USE-2 or equivalent. The module cables should also be attached and supported to ensure adequate strain relief. If cables are installed within a building then they should be installed in metallic cable conduits.

⚠ CAUTION

When selecting the minimum current carrying capacity of the cable please refer to the typical short circuit current (Isc) rating* and multiply this by 1.56 times the number of solar modules connected in parallel. Note that further safety factors may be required depending upon the ambient temperature of the installation and the means of installation of the cables (e.g. conduit installation). Refer to the local standards to ensure full compliance with legislation.

⚠ CAUTION

Under normal conditions, a photovoltaic module is likely to experience conditions that produce more current and/or voltage than reported at Standard Test Conditions. Accordingly, the values of Isc and Voc marked on this module* should be multiplied by a factor of 1.25 when determining component voltage ratings, conductor ampacities, fuse sizes, and size of controls connected to the PV output. Refer to Section 690-8 of the National Electrical Code for an additional multiplying factor of 125 percent (80 percent derating) which may be applicable.

**Please note the following:* the Isc and Voc ratings are printed on the product data sheet as well as the label adhered to the rear side of the solar module

Series and Parallel Wiring

The modules may be wired in series to produce the desired voltage output in the range of maximum system voltage and input voltage of the required inverter. Connect the modules in series electrically by connecting the positive (+) connector of one module to the negative (-) connector of another. Only use modules of the same type for series connections. An arrangement of several solar modules which are connected in series is often referred to as a “module string”.

To determine the maximum number of modules that may be connected in series, divide the maximum system voltage as stated on the module label (or the maximum allowed by local standards or codes, whichever is less) by the module open circuit voltage (Voc) printed on the label, after correcting for temperature as required by local codes or standards.

The number of module strings connected in parallel without protective fuses should be limited to two. If more than two strings are to be connected in parallel, then a series fuse is required for each string in each non-earthed pole. Only DC fuses rated at the maximum system voltage should be used. Maximum fuse rating should not exceed the maximum system voltage rating stated on the module label.

DC Fuse Ratings

To calculate the minimum fuse size, multiply the short circuit current (Isc) rating of the module by a factor of 1.56. The Isc value must take into consideration the maximum irradiation and temperature of the installation site. If the loss of a fuse connection occurs, verify that the maximum current rating was considered when calculating the fuse rating.



CAUTION

DO NOT connect or disconnect a Bosch Solar Energy module unless the array string is open-circuited or all of the modules in the array string are covered. Take appropriate steps to black out the top (cell side) of the solar modules as much as possible. The connectors are not designed to make or break the full system current. Do not direct concentrated artificial lighting sources on the modules or panels.

B. Grounding

In order to ensure a code compliant installation, requirements for earth grounding and lightning protection must be followed. In the United States, the grounding methods must comply with Articles 250 and 690 of the National Electric Code (NEC).

According to the NEC, the installer must ground the module frame. Use only UL Listed grounding lugs suitable for outdoor. Alternate means of module grounding not covered within this Manual may be acceptable. Contact Bosch Solar Energy for additional information regarding the use of additional grounding techniques.

Please refer to Figure 7B for a typical earth grounding method for the module utilizing ground lugs.

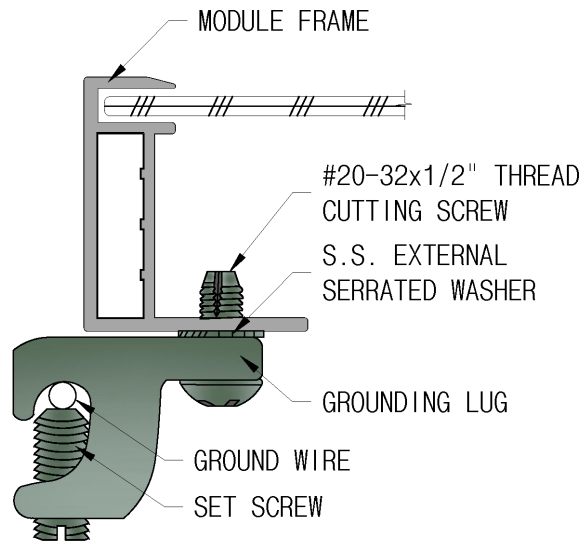

Figure 7B: Installation of the grounding lug

In this grounding method the serrated ‘star’ washers are required for making a reliable ground connection through the anodized coating and into the aluminum frame as well as to prevent loosening of the screw over time.

An alternative method of attaching the grounding lugs may require the use of #8-32 (4mm) bolts, nut, star washers and lock washers. The ground lug shall be installed from the bottom side of the frame using the paint cutting star washers, lock washer and bolt. Torque the hex bolt (if used) to 50-70 in-lbs. This ground hardware can accommodate a 14AWG through 4AWG bare (stranded or solid) wire.

8. STORING, TRANSPORTING AND UNPACKING SOLAR MODULES

A. Packaging

Bosch Solar Energy modules are shipped in pallet box assemblies that are specially designed to provide the proper protection during shipment. The pallet box consists of the following components:

- 1) Wooden pallet
- 2) Plastic module corner protectors
- 3) Cardboard base, sleeve and cap

It is important to note that the pallets and plastic module corner protectors are the main components of the packaging assembly that bare the vertical load.

Pallet Box Specifications

Quantity	Dimensions (L x W x H)	Weight	Stack Limitation
23 modules	1,728 x 1,148 x 1205 mm 68.03 x 45.20 x 47.44 in.	470 kg 1,026 lbs	Maximum 2 boxes

The pallet box dimensions are shown in Figure 8A below.

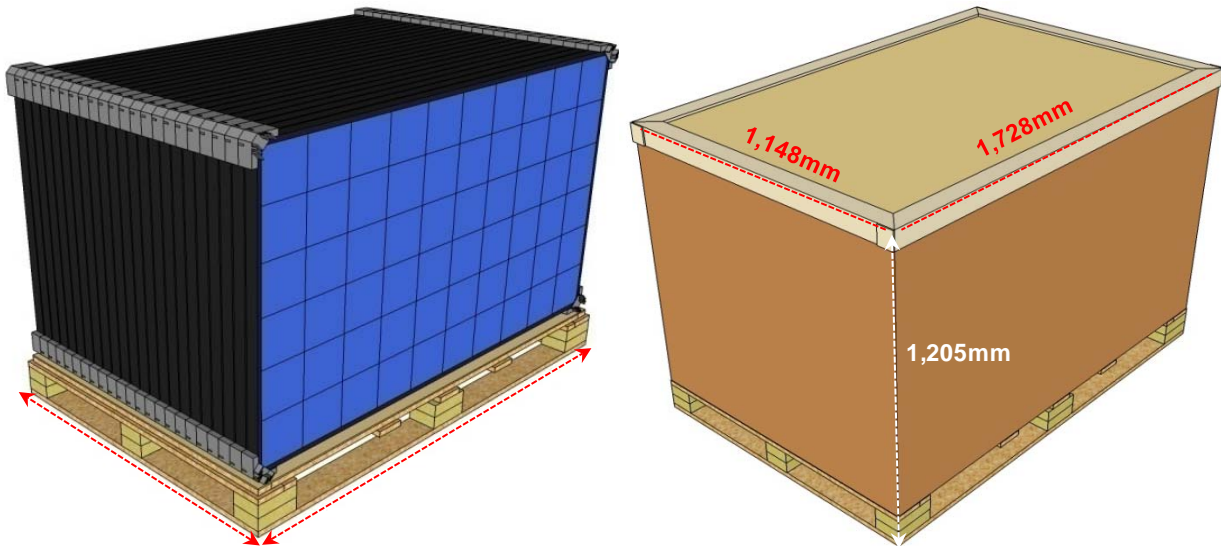

Figure 8A: Pallet Box Dimensions

Whenever the Bosch Solar Energy modules are stored or transported, care must be exercised to ensure that they are stood upright in the packing units and that there is sufficient area to support each solar module. Each module must also be secured against tipping over. When solar modules are transported, they must always be in an upright position. Transporting the modules in a horizontal position is not allowed.

B. Unpacking Instructions

Bosch Solar Energy modules are shipped in a pallet box assembly as shown in Figure 8B. To unpack the assembly, please use the following procedure:

- 1) Cut the polyethylene straps with cutting tools.
- 2) Remove the upper cap.
- 3) Lift up and remove the sleeve.
- 4) Remove the plastic bag with a cutting tool.
- 5) Remove the modules one at a time

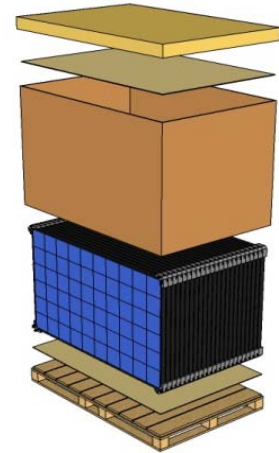

Figure 8B: Pallet Box Assembly

C. Safety Considerations

Bosch recommends that the solar modules be stored indoors in their original packaging until ready for final installation. Dry storage conditions are important for protecting the integrity of the cardboard assembly components. Loose solar modules should be stored standing upright on wedge-shaped corner protectors with suitable padding. Adequate padding must be placed between the individual solar modules as well. The solar modules should be secured against tipping over.



CAUTION: Always adhere to the following pallet box handling precautions:

- 1) The module contains glass and is fragile. Handle the transportation box as well as the PV module with care.

- 2) Wear gloves to avoid injury by sharp edges

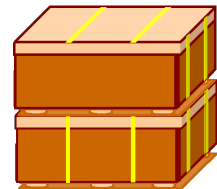

- 3) **DO NOT** stack more than 2 pallet boxes on top of one another

- 4) **DO NOT** get pallet or cardboard components wet as they may collapse after long-term exposure to moisture

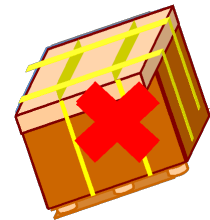

- 5) Always maintain the pallet box in flat position. Stacking on uneven ground may cause module breakage.

- 6) Move 2 boxes at a time when transporting by fork lift



- 7) **DO NOT** cut the polyethylene straps until installation commences

9. PRODUCT SUPPORT

Bosch Solar Energy is committed to offering high-quality products which are safe and reflect the state of the art in technology – today and in the future. We value feedback and ideas from our installers and users to help make our solar products better. For information or for service and technical support on Bosch Solar Energy products, please contact Bosch Solar Energy via one of the methods listed below:

E-mail: solarenergy@us.bosch.com

Telephone: +1 650 356 3100

Website: www.bosch-solarenergy.com

10. CARE AND MAINTENANCE

Bosch Solar Energy modules require minimal care and maintenance in order to provide high performance. Bosch Solar Energy recommends that system maintenance is carried out by qualified personnel on a regular basis. This maintenance may include such tasks as verification of the integrity of the electrical and mechanical connections, checking that any system alarms are operating correctly and cleaning of the solar modules as required.

A. Module Cleaning

Solar modules may become soiled to varying degrees depending upon surrounding conditions and this may reduce their performance. Periodic cleaning of the modules will ensure maximum output. However, if modules are installed at height (e.g. on a roof) then cleaning should only be performed by qualified personnel



CAUTION: When cleaning solar modules please take the following precautions:

- Clean the module surface with a soft cloth or sponge using clean and neutral water base (non-ammonia). To remove stubborn dirt you can use a mild, non-abrasive cleaning agent or alcohol.
- Only clean modules in the early morning or in the late afternoon when there is low solar radiation and cells are producing less energy
- **DO NOT** use either high-pressurized water, a steam cleaner or any kind of aggressive tool or material that could scratch the surface of the modules.
- **DO NOT** clean the modules with hot water when the ambient temperature is low or with cold water when the modules are hot.
- **DO NOT** attempt to remove snow or ice from the modules by means of scraping. Use a soft brush to avoid creating micro-scratches in the module glass.

B. Inspection and Repair

When carrying out an inspection, please check that the electrical and mechanical connections are clean, secure and undamaged. Be sure to take precautions against electric shock in the event of any defects. Any faults must be rectified promptly.

Should any repairs become necessary to a Bosch Solar Energy module, it is essential that you contact Bosch Solar Energy. Never under any circumstances attempt to repair the solar module yourself! Bosch Solar Energy modules must only be serviced by specialist firms authorized by Bosch; otherwise the product and performance warranties may be voided.

11. END OF LIFE

When solar modules reach the end of their service life, they must be disposed of in accordance with all relevant local, state, and national laws and regulations. They must never be disposed of as household waste. It is the responsibility of the user to ensure that this product is disposed of properly. Please contact your local waste disposal center or Bosch Solar Energy if you have any questions concerning the proper disposal of this product.